

This proposed change is a result of the CTC's investigation of the area of study entitled "Child Window Safety". The scope of the activity is noted as:

To study the incidence and mechanisms of falls from open windows by children and to investigate the necessity and suitability of potential safeguards and/or revisions to the current codes.

The CTC established a study group to review available materials on the issue of child falls through windows. It became readily apparent that public education is a key consideration in reducing the number of falls by children through windows. As far as the code is concerned, the group focused on two possible means of addressing this issue. The two being:

- Window screens
- Window fall prevention devices

This proposal provides both options, in the form of exceptions to the minimum sill height requirements in the code.

Window screens: ANSI/SMA 6001 is a standard entitled "Specifications for Metal Protection Screens. ".As noted in Section 2.1 of the standard, "This specification provides, definitions, methods of test, and performance requirements for metal protection screens designed and manufactured primarily for installation in window openings for the purpose of providing security for the building occupants by restraining of deterring forced entry and by protecting the window from vandalism". While not specifically noting the screens use as a barrier to restrain a child, the study group concluded that their key considerations is that of providing some type of barrier. Screens designed in accordance with this standard are classified under the following classes:

Light: Load resistance between 30 – 75 pounds

Medium: Load resistance between 75 - 150 pounds.

Heavy: Load resistance between 150 – 300 pounds.

Window fall prevention devices: ASTM F 2090 is a standard entitled "Window Fall Prevention Devices with Emergency Escape (Egress) Release Mechanisms". As noted in Section 1.1 of the standard, "This specification establishes requirements for devices intended to address the risk of injury and death associated with accidental falls from windows by children five years old and younger. The key operational constraint of devices which comply with this standard is compliance with Section 4.1, which states: "Window fall prevention devices shall be constructed so as to prohibit the free passage of a 4.0 in diameter rigid sphere at any point, during or after testing as specified in Section 8, when the window fall prevention device is installed in accordance with the manufactures instructions.

Proposed Section R 613.4 and 1405.12.4.2, including Items 1 – 3, is a codified version of Sections 4.1, 4.3.2, 4.3.4 of ASTM F 2090. Item 4 is primarily a reminder that full compliance with Section R 310.1.1 is required for all emergency escape and rescue openings of the window serves such purpose.

Cost Impact: The code change will increase the cost of construction if the devices are used.

PART I – IRC

Committee Action:

Disapproved

Committee Reason: The standard is not ready at this time. It is unknown how many windows on the market that can meet this. The proponent should work with industry and bring this back. Also, it is not clear if Section R613.4.2 applies to all windows.

Assembly Action:

None

Individual Consideration Agenda

This item is on the agenda for individual consideration because public comments were submitted.

Public Comment 1:

Paul Heilstedt, PE, FAIA, Chair, representing ICC Code Technology Committee (CTC), requests Approval as Modified by this Public Comment.

Modify proposal as follows:

R613.2 Window sills. In dwelling units, where the opening of an operable window is located more than 72 inches (1829 mm) above the finished grade or surface below, the lowest part of the clear opening of the window shall be a minimum of ~~24~~ 36 inches (610 mm) above the finished floor of the room in which the window is located. Glazing between the floor and ~~24~~ 36 inches (610 mm) shall be fixed or have openings through which a 4-inch-diameter (102 mm) sphere cannot pass.

Exceptions:

1. Windows whose openings will not allow a 4-inch-diameter (102 mm) sphere to pass through the opening when the opening is in its largest opened position.
2. Openings that are provided with window fall prevention devices that comply with R613.3.
3. Openings that are provided with fall prevention devices that comply with ASTM F 2090 or screens that comply with SMA 6001.
4. Windows that are provided with opening limiting devices that comply with Section R613.4.

(Portions of proposal not shown remain unchanged)

Commenter's Reason: The intent of RB 173 is clearly to provide safety mechanisms to reduce the possibility of children falling through a window. The CTC has determined that this can be realized in the code in three ways: window fall prevention devices; window opening control devices; or reducing the possibility by increasing the minimum sill height. CTC has submitted two public comments which deal with the fall prevention devices and window opening control devices. The purpose of this public comment is to reduce the potential hazard by increasing the sill height from 24 inches to 36 inches.

In response to the CTC studying the Climability of Guards, the National Ornamental & Miscellaneous Metals Association (NOMMA) commissioned a paper entitled "Review of Fall Safety of Children Between the Ages of 18 months and 4 Years in Relation to Guards and Climbing in the Built Environment", referred to in this code change as "NOMMA paper". This paper is posted on the CTC website as noted below. The paper provides a summary of the building code requirements, a critical review of relevant peer-reviewed scientific literature on guard research and injury data and includes a section entitled "Children's Interaction with the Built Environment". Included in this section is an analysis of falls from windows where it is noted that "Falls from windows are among the most common types of unintended injuries to children and they are a major health concern" (NOMMA paper page 30). The study efficiently places within a few pages the data on window fall incidents and the means of reducing the number of incidents.

U.S. Fall Injury Data

NOMMA report page 7: The 1,421,137 injuries reported by NEISS between 2002 and 2005, inclusive, correspond to a national average of 51,217,603 based on weighting data included with the record data. The average over the four years is 12,804,401. The weighted estimate of 1,117,278 incidents on average annually for children between the ages of 18 months and 4 years represents 8.7 percent of these incidents. For all the incidents to children between the ages of 18 months and 4 years, 5.6 percent involved stairs, 1.22 percent involved windows, and 0.87 percent involved porches, balconies, open-sided floors, and floor openings.

NOMMA paper page 30 – 33. The paper further cites reports which have been compiled in the table below:

Study	Location	Falls	% fatalities
Vish et al. (2005)	Chicago	11/yr	
Istre et al. (2003)	Dallas county	17/yr	
Benoit et al. (2002)	L.A. county	12/yr (11%)	4% (4 yrs old or less)
Stone et al. (2000)	Cincinnati	12/yr (6.3%)	4.7%
Benoit et al. (2000)	Northern Virginia	11/yr (11%)	

Center of Gravity

NOMMA paper page 11, Table 2: The standing center of gravity of children aged 2 to 3.5 years is 24.1 inches (50th percentile is 22.2 inches) and of children aged 3.5 to 4.5 is 25.2 (50th percentile is 23.6).

A reasonable expectation for the Code is that, absent any fall protection in the window opening, a minimum sill height will be required to reduce the ability of a child to climb onto the sill enabling the fall through the opening. Using a child target age of up to 4 years of age and the associated center of gravity, the code mandated height of 24" is not adequate. A child need only extend themselves on their toes, stand on modest stack of books or blocks or hoist themselves a matter of a few inches with their arms to be able to flop onto the sill and expose themselves to the window opening and the associated risk of falling.

The hazards associated with child window falls can not be understated as evidenced by the following CPSC Press release dated May 15, 2008:

NEWS from CPSC
 U.S. Consumer Product Safety Commission
 Office of Information and Public Affairs Washington, DC 20207

FOR IMMEDIATE RELEASE
 May 15, 2008
 Release #08-270

CPSC Hotline: (800) 638-2772
 CPSC Media Contact: (301) 504-7908

Window Falls Prompts CPSC to Issue Warning

WASHINGTON, D.C. - With the arrival of the warmer spring weather, families across the nation are opening their windows to let the fresh air in. This pleasant feeling can quickly turn tragic in households with small children. In recent weeks, several children have fallen from windows. The U.S. Consumer Product Safety Commission is warning parents and caregivers to take precautions to keep children from falling from windows.

"CPSC staff is aware of at least 18 falls from windows through media reports, including two deaths, involving small children since April," said CPSC Acting Chairman Nancy Nord. "We are issuing this warning so parents will take the necessary steps to prevent these incidents from happening."

These deaths and injuries frequently occur when kids push themselves against window screens or climb onto furniture located next to an open window.

From 2002-2004, CPSC staff received an average of 25 reports a year of fatalities associated with falls from windows. Children younger than five years of age account for approximately one-third of these reported fatalities. For all age categories, more males died from window falls than females.

To help prevent injuries and tragedies, CPSC recommends the following safety tips:

- * Safeguard your children by using window guards or window stops.
- * Install window guards to prevent children from falling out of windows. (For windows on the 6th floor and below, install window guards that adults and older children can open easily in case of fire.)

- * Install window stops so that windows open no more than 4 inches.
- * Never depend on screens to keep children from falling out of windows.
- * Whenever possible, open windows from the top -- not the bottom.
- * Keep furniture away from windows, to discourage children from climbing near windows.

To see this release on CPSC's web site, please go to:
<http://www.cpsc.gov/cpsc/pub/prerelease/prhtml08/08270.html>

Code issues are assigned to the CTC by the ICC Board as "areas of study". Information on the CTC, including: meeting agendas; minutes; reports; resource documents; presentations; and all other materials developed in conjunction with the CTC effort can be downloaded from the following website: <http://www.iccsafe.org/cs/cc/ctc/index.html>. Since its inception in April/2005, the CTC has held fifteen meetings - all open to the public. This public comment is a result of the CTC's investigation of the area of study entitled "Child Window Safety". The CTC web page for this area of study is: <http://www.iccsafe.org/cs/cc/ctc/window.html>

Public Comment 2:

Paul Heilstedt, PE, FAIA, Chair, representing ICC Code Technology Committee (CTC), requests Approval as Modified by this Public Comment.

Modify proposal as follows:

R613.2 Window sills. In dwelling units, where the opening of an operable window is located more than 72 inches (1829 mm) above the finished grade or surface below, the lowest part of the clear opening of the window shall be a minimum of 24 inches (610 mm) above the finished floor of the room in which the window is located. ~~Glazing between the floor and 24 inches (610 mm) shall be fixed or have openings through which a 4-inch diameter (102 mm) sphere cannot pass.~~ Operable sections of windows shall not permit openings that allow passage of a 4 inch diameter sphere where such openings are located within 24 inches of the finished floor.

Exceptions:

1. Windows whose openings will not allow a 4-inch-diameter (102 mm) sphere to pass through the opening when the opening is in its largest opened position.
2. Openings that are provided with window fall prevention devices that comply with R613.3.
3. Openings that are provided with fall prevention devices that comply with ASTM F 2090 ~~or screens that comply with SMA 6004.~~
4. Windows that are provided with opening limiting devices that comply with Section R613.4.

(Portions of proposal not shown remain unchanged)

Commenter's Reason: The purpose of this public comment is two fold: to clarify the language dealing with glazing below the 24 inch height and to remove the reference to the proposed new standard.

Glazing below the 24 inch threshold is a hazard only where the glazing includes an operable section. The change to R6132 in the IRC and 1405.12.2 in the IBC clarifies the application of this section to only operable sections.

The proposed reference to the SMA standard is proposed for deletion in Exception 3 in both codes. While the SMA is indeed a screen standard, it has been brought to the attention of the CTC that the standard was never intended to regulate screens for the purpose of providing a barrier to children when placed in a window.

The hazards associated with child window falls can not be understated as evidenced by the following CPSC Press release dated May 15, 2008:

NEWS from CPSC
 U.S. Consumer Product Safety Commission
 Office of Information and Public Affairs Washington, DC 20207

FOR IMMEDIATE RELEASE
 May 15, 2008
 Release #08-270

CPSC Hotline: (800) 638-2772
 CPSC Media Contact: (301) 504-7908

Window Falls Prompts CPSC to Issue Warning

WASHINGTON, D.C. - With the arrival of the warmer spring weather, families across the nation are opening their windows to let the fresh air in. This pleasant feeling can quickly turn tragic in households with small children. In recent weeks, several children have fallen from windows. The U.S. Consumer Product Safety Commission is warning parents and caregivers to take precautions to keep children from falling from windows.

"CPSC staff is aware of at least 18 falls from windows through media reports, including two deaths, involving small children since April," said CPSC Acting Chairman Nancy Nord. "We are issuing this warning so parents will take the necessary steps to prevent these incidents from happening."

These deaths and injuries frequently occur when kids push themselves against window screens or climb onto furniture located next to an open window.

From 2002-2004, CPSC staff received an average of 25 reports a year of fatalities associated with falls from windows. Children younger than five years of age account for approximately one-third of these reported fatalities. For all age categories, more males died from window falls than females.

To help prevent injuries and tragedies, CPSC recommends the following safety tips:

- * Safeguard your children by using window guards or window stops.
- * Install window guards to prevent children from falling out of windows. (For windows on the 6th floor and below, install window guards

- that adults and older children can open easily in case of fire.)
- * Install window stops so that windows open no more than 4 inches.
 - * Never depend on screens to keep children from falling out of windows.
 - * Whenever possible, open windows from the top -- not the bottom.
 - * Keep furniture away from windows, to discourage children from climbing near windows.

To see this release on CPSC's web site, please go to:
<http://www.cpsc.gov/cpsc/pub/prerel/prhtml08/08270.html>

Code issues are assigned to the CTC by the ICC Board as "areas of study". Information on the CTC, including: meeting agendas; minutes; reports; resource documents; presentations; and all other materials developed in conjunction with the CTC effort can be downloaded from the following website: <http://www.iccsafe.org/cs/cc/ctc/index.html>. Since its inception in April/2005, the CTC has held fifteen meetings - all open to the public. This public comment is a result of the CTC's investigation of the area of study entitled "Child Window Safety". The CTC web page for this area of study is: <http://www.iccsafe.org/cs/cc/ctc/window.html>

Public Comment 3:

Paul Heilstedt, PE, FAIA, Chair, representing ICC Code Technology Committee (CTC), requests Approval as Modified by this Public Comment.

Modify proposal as follows:

R613.2 Window sills. In dwelling units, where the opening of an operable window is located more than 72 inches (1829 mm) above the finished grade or surface below, the lowest part of the clear opening of the window shall be a minimum of 24 inches (610 mm) above the finished floor of the room in which the window is located. Glazing between the floor and 24 inches (610 mm) shall be fixed or have openings through which a 4-inch-diameter (102 mm) sphere cannot pass.

Exceptions:

1. Windows whose openings will not allow a 4-inch-diameter (102 mm) sphere to pass through the opening when the opening is in its largest opened position.
2. Openings that are provided with window fall prevention devices that comply with R613.3.
3. Openings that are provided with fall prevention devices that comply with ASTM F 2090 or screens that comply with SMA 6001.
4. Windows that are provided with window opening limiting control devices that comply with Section R613.4.

R613.4 Window opening limiting control devices. When required elsewhere in this code, window opening limiting control devices shall comply with the provisions of ~~this section~~ ASTM F2090.

~~**R613.4.1 General requirements.** Window opening limiting devices shall be self-acting and shall be positioned so as to prohibit the free passage of a 4.0-in. (102-mm) diameter rigid sphere through the window opening when the window opening limiting device is installed in accordance with the manufacturer's instructions.~~

~~**R613.4.2 Operation for Emergency Escape.** Window opening limiting devices shall be designed with release mechanisms to allow for emergency escape through the window opening without the need for keys, tools or special knowledge. Window opening limiting devices shall comply with all of the following:~~

- ~~1. Release of the window opening limiting device shall require no more than 15 lbf (66 N) of force.~~
- ~~2. The window opening limiting device release mechanism shall operate properly in all types of weather.~~
- ~~3. Window opening limiting devices shall have their release mechanisms clearly identified for proper use in an emergency.~~
- ~~4. The window opening limiting device shall not reduce the minimum net clear opening area of the window unit below what is required by Section R310.1.1 of the code.~~

(Portions of proposal not shown remain unchanged)

Commenter's Reason: The IBC and IRC currently reference ASTM F2090 -1001a entitled "Specification for Window Fall Prevention Devices with Emergency Escape (Egress) Release Mechanisms" as an exception for the minimum sill height requirements in the code. As referenced, the scope of the current version addresses only window fall prevention devices. However, the standard is currently being updated to address window opening control devices. In anticipation of the update being completed by the 2008 Final Action Hearings, the CTC is proposing that the text as proposed which was intended to provide performance criteria for such devices be replaced by the industry standard which comprehensively addresses such devices. It should be noted that as of the submission of this public comment, the status of the update process is one of the standard being revised based on previous committee ballots. If the standard is not completed, this public comment will not be pursued at the hearings.

The hazards associated with child window falls can not be understated as evidenced by the following CPSC Press release dated May 15, 2008:

NEWS from CPSC
 U.S. Consumer Product Safety Commission
 Office of Information and Public Affairs Washington, DC 20207

FOR IMMEDIATE RELEASE
 May 15, 2008
 Release #08-270
 CPSC Hotline: (800) 638-2772
 CPSC Media Contact: (301) 504-7908

Window Falls Prompts CPSC to Issue Warning

WASHINGTON, D.C. - With the arrival of the warmer spring weather, families across the nation are opening their windows to let the fresh air in. This pleasant feeling can quickly turn tragic in households with small children. In recent weeks, several children have fallen from windows. The U.S. Consumer Product Safety Commission is warning parents and caregivers to take precautions to keep children from falling from windows.

"CPSC staff is aware of at least 18 falls from windows through media reports, including two deaths, involving small children since April," said CPSC Acting Chairman Nancy Nord. "We are issuing this warning so parents will take the necessary steps to prevent these incidents from happening."

These deaths and injuries frequently occur when kids push themselves against window screens or climb onto furniture located next to an open window.

From 2002-2004, CPSC staff received an average of 25 reports a year of fatalities associated with falls from windows. Children younger than five years of age account for approximately one-third of these reported fatalities. For all age categories, more males died from window falls than females.

To help prevent injuries and tragedies, CPSC recommends the following safety tips:

- * Safeguard your children by using window guards or window stops.
- * Install window guards to prevent children from falling out of windows. (For windows on the 6th floor and below, install window guards that adults and older children can open easily in case of fire.)
- * Install window stops so that windows open no more than 4 inches.
- * Never depend on screens to keep children from falling out of windows.
- * Whenever possible, open windows from the top -- not the bottom.
- * Keep furniture away from windows, to discourage children from climbing near windows.

To see this release on CPSC's web site, please go to:

<http://www.cpsc.gov/cpscpub/prerele/prhtml08/08270.html>

Code issues are assigned to the CTC by the ICC Board as "areas of study". Information on the CTC, including: meeting agendas; minutes; reports; resource documents; presentations; and all other materials developed in conjunction with the CTC effort can be downloaded from the following website: <http://www.iccsafe.org/cs/cc/ctc/index.html>. Since its inception in April/2005, the CTC has held fifteen meetings - all open to the public. This public comment is a result of the CTC's investigation of the area of study entitled "Child Window Safety". The CTC web page for this area of study is: <http://www.iccsafe.org/cs/cc/ctc/window.html>

Final Action: AS AM AMPC____ D

RB173-07/08, Part II

R613.2, R613.3, R613.4, R613.4.1, R613.4.2 (New), Chapter 43 (New); IBC 1405.12.2, 1405.12.3 (New), 1405.12.4 (New), 1405.12.4.1 (New), 1405.12.4.2 (New), Chapter 35 (New)

Proposed Change as Submitted:

Proponent: Paul Heilstedt, Chair for the Code Technology Committee

PART II – IBC FIRE SAFETY

1. Revise as follows:

1405.12.2 Window sills. In Occupancy Groups R-2 and R-3, one- and two-family and multiple-family dwellings, where the opening of the sill portion of an operable window is located more than 72 inches (1829 mm) above the finished grade or other surface below, the lowest part of the clear opening of the window shall be a minimum of 24 inches (610 mm) above the finished floor surface of the room in which the window is located. Glazing between the floor and a height of 24 inches (610 mm) shall be fixed or have openings such that a 4-inch (102 mm) diameter sphere cannot pass through.

Exceptions:

1. Windows whose openings will not allow a 4-inch diameter (102 mm) sphere to pass through the opening when the opening is in its largest opened position.
2. Openings that are provided with window fall prevention devices guards that comply with 1405.12.3 ASTM F 2006 or F 2090.
3. Openings that are provided with fall prevention devices that comply with ASTM F 2090 or screens that comply with SMA 6001.
4. Windows that are provided with opening limiting devices that comply with Section 1405.12.4.

2. Add new text as follows:

1405.12.3 Window fall prevention devices. Window fall prevention devices and window guards, where provided, shall comply with the requirements of ASTM F 2090.

1405.12.4 Window opening limiting devices. When required elsewhere in this code, window opening limiting devices shall comply with the provisions of this section.

1405.12.4.1 General requirements. Window opening limiting devices shall be self acting and shall be positioned so as to prohibit the free passage of a 4.0-in. (102-mm) diameter rigid sphere through the window opening when the window opening limiting device is installed in accordance with the manufacturer's instructions.

1405.12.4.2 Operation for emergency escape. Window opening limiting devices shall be designed with release mechanisms to allow for emergency escape through the window opening without the need for keys, tools or special knowledge. Window opening limiting devices shall comply with all of the following:

1. Release of the window opening-limiting device shall require no more than 15 lbf (66 N) of force.
2. The window opening limiting device release mechanism shall operate properly in all types of weather.
3. Window opening limiting devices shall have their release mechanisms clearly identified for proper use in an emergency.
4. The window opening limiting device shall not reduce the minimum net clear opening area of the window unit below what is required by Section R310.1.1 of the code.

3. Add standard to Chapter 35 as follows:

SMA 6001-2002 Specifications for Metal Protection Screens

Reason: The ICC Board established the ICC Code Technology Committee (CTC) as the venue to discuss contemporary code issues in a committee setting which provides the necessary time and flexibility to allow for full participation and input by any interested party. The code issues are assigned to the CTC by the ICC Board as "areas of study". Information on the CTC, including: meeting agendas; minutes; reports; resource documents; presentations; and all other materials developed in conjunction with the CTC effort can be downloaded from the following website: <http://www.iccsafe.org/cs/cc/ctc/index.html> Since its inception in April/2005, the CTC has held twelve meetings - all open to the public.

This proposed change is a result of the CTC's investigation of the area of study entitled "Child Window Safety". The scope of the activity is noted as:

To study the incidence and mechanisms of falls from open windows by children and to investigate the necessity and suitability of potential safeguards and/or revisions to the current codes.

The CTC established a study group to review available materials on the issue of child falls through windows. It became readily apparent that public education is a key consideration in reducing the number of falls by children through windows. As far as the code is concerned, the group focused on two possible means of addressing this issue. The two being:

- Window screens
- Window fall prevention devices

This proposal provides both options, in the form of exceptions to the minimum sill height requirements in the code.

Window screens: ANSI/SMA 6001 is a standard entitled "Specifications for Metal Protection Screens. ". As noted in Section 2.1 of the standard, "This specification provides, definitions, methods of test, and performance requirements for metal protection screens designed and manufactured primarily for installation in window openings for the purpose of providing security for the building occupants by restraining of deterring forced entry and by protecting the window from vandalism". While not specifically noting the screens use as a barrier to restrain a child, the study group concluded that they key considerations is that of providing some type ob barrier. Screens designed in accordance with this standard are classified under the following classes:

Light: Load resistance between 30 – 75 pounds

Medium: Load resistance between 75 - 150 pounds.

Heavy: Load resistance between 150 – 300 pounds.

Window fall prevention devices: ASTM F 2090 is a standard entitled "Window Fall Prevention Devices with Emergency Escape (Egress) Release Mechanisms". As noted in Section 1.1 of the standard, "This specification establishes requirements for devices intended to address the risk of injury and death associated with accidental falls from windows by children five years old and younger. The key operational constraint of devices which comply with this standard is compliance with Section 4.1, which states: "Window fall prevention devices shall be constructed so as to prohibit the free passage of a 4.0 in diameter rigid sphere at any point, during or after testing as specified in Section 8, when the window fall prevention device is installed in accordance with the manufactures instructions.

Proposed Section R 613.4 and 1405.12.4.2, including Items 1 – 3, is a codified version of Sections 4.1, 4.3.2, 4.3.4 of ASTM F 2090. Item 4 is primarily a reminder that full compliance with Section R 310.1.1 is required for all emergency escape and rescue openings of the window serves such purpose.

Cost Impact: The code change will increase the cost of construction if the devices are used.

PART II – IBC FIRE SAFETY

Committee Action:

Disapproved

Committee Reason: Based on subjective language, undefined terms and a lack of prescriptive criteria the committee agreed to disapprove this proposal. An example of subjective language is "all types of weather" found in item 2 of Section 1405.12.4.2. An example of an undefined term is "opening-limiting device" found in several locations throughout the proposal. Subjective language and undefined terms create compliance and enforcement difficulties.

Assembly Action:

None

Individual Consideration Agenda

This item is on the agenda for individual consideration because public comments were submitted.

Public Comment 1:

Paul Heilstedt, PE, FAIA, Chair, representing ICC Code Technology Committee (CTC), requests Approval as Modified by this Public Comment.

Modify proposal as follows:

1405.12.2 Window sills. In Occupancy Groups R-2 and R-3, one- and two-family and multiple-family dwellings, where the opening of the sill portion of an operable window is located more than 72 inches (1829 mm) above the finished grade or other surface below, the lowest part of the clear opening of the window shall be a minimum of 24 36 inches (610 mm) above the finished floor surface of the room in which the window is located. Glazing between the floor and a height of 24 36 inches (610 mm) shall be fixed or have openings such that a 4-inch (102 mm) diameter sphere cannot pass through.

Exceptions:

1. Windows whose openings will not allow a 4-inch diameter (102 mm) sphere to pass through the opening when the opening is in its largest opened position.
2. Openings that are provided with window fall prevention devices that comply with 1405.12.3.
3. Openings that are provided with fall prevention devices that comply with ASTM F 2090 or screens that comply with SMA 6001.
4. Windows that are provided with opening limiting devices that comply with Section 1405.12.4.

(Portions of proposal not shown remain unchanged)

Commenter's Reason: The intent of RB 173 is clearly to provide safety mechanisms to reduce the possibility of children falling through a window. The CTC has determined that this can be realized in the code in three ways: window fall prevention devices; window opening control devices; or reducing the possibility by increasing the minimum sill height. CTC has submitted two public comments which deal with the fall prevention devices and window opening control devices. The purpose of this public comment is to reduce the potential hazard by increasing the sill height from 24 inches to 36 inches.

In response to the CTC studying the Climability of Guards, the National Ornamental & Miscellaneous Metals Association (NOMMA) commissioned a paper entitled "Review of Fall Safety of Children Between the Ages of 18 months and 4 Years in Relation to Guards and Climbing in the Built Environment", referred to in this code change as "NOMMA paper". This paper is posted on the CTC website as noted below. The paper provides a summary of the building code requirements, a critical review of relevant per-reviewed scientific literature on guard research and injury data and includes a section entitled "Children's Interaction with the Built Environment". Included in this section is an analysis of falls from windows where it is noted that "Falls from windows are among the most common types of unintended injuries to children and they are a major health concern" (NOMMA paper page 30). The study efficiently places within a few pages the data on window fall incidents and the means of reducing the number of incidents.

U.S. Fall Injury Data

NOMMA report page 7: The 1,421,137 injuries reported by NEISS between 2002 and 2005, inclusive, correspond to a national average of 51,217,603 based on weighting data included with the record data. The average over the four years is 12,804,401. The weighted estimate of 1,117,278 incidents on average annually for children between the ages of 18 months and 4 years represents 8.7 percent of these incidents. For all the incidents to children between the ages of 18 months and 4 years, 5.6 percent involved stairs, 1.22 percent involved windows, and 0.87 percent involved porches, balconies, open-sided floors, and floor openings.

NOMMA paper page 30 – 33. The paper further cites reports which have been compiled in the table below:

Study	Location	Falls	% fatalities
Vish et al. (2005)	Chicago	11/yr	
Istre et al. (2003)	Dallas county	17/yr	
Benoit et al. (2002)	L.A. county	12/yr (11%)	4% (4 yrs old or less)
Stone et al. (2000)	Cincinnati	12/yr (6.3%)	4.7%
Benoit et al. (2000)	Northern Virginia	11/yr (11%)	

Center of Gravity

NOMMA paper page 11, Table 2: The standing center of gravity of children aged 2 to 3.5 years is 24.1 inches (50th percentile is 22.2 inches) and of children aged 3.5 to 4.5 is 25.2 (50th percentile is 23.6).

A reasonable expectation for the Code is that, absent any fall protection in the window opening, a minimum sill height will be required to reduce the ability of a child to climb onto the sill enabling the fall through the opening. Using a child target age of up to 4 years of age and the associated center of gravity, the code mandated height of 24" is not adequate. A child need only extend themselves on their toes, stand on modest stack of books or blocks or hoist themselves a matter of a few inches with their arms to be able to flop onto the sill and expose themselves to the window opening and the associated risk of falling.

The hazards associated with child window falls can not be understated as evidenced by the following CPSC Press release dated May 15, 2008:

NEWS from CPSC
U.S. Consumer Product Safety Commission
Office of Information and Public Affairs Washington, DC 20207
FOR IMMEDIATE RELEASE
May 15, 2008
Release #08-270
CPSC Hotline: (800) 638-2772
CPSC Media Contact: (301) 504-7908
Window Falls Prompts CPSC to Issue Warning

WASHINGTON, D.C. - With the arrival of the warmer spring weather, families across the nation are opening their windows to let the fresh air in. This pleasant feeling can quickly turn tragic in households with small children. In recent weeks, several children have fallen from windows. The U.S. Consumer Product Safety Commission is warning parents and caregivers to take precautions to keep children from falling from windows.

"CPSC staff is aware of at least 18 falls from windows through media reports, including two deaths, involving small children since April," said CPSC Acting Chairman Nancy Nord. "We are issuing this warning so parents will take the necessary steps to prevent these incidents from happening."

These deaths and injuries frequently occur when kids push themselves against window screens or climb onto furniture located next to an open window.

From 2002-2004, CPSC staff received an average of 25 reports a year of fatalities associated with falls from windows. Children younger than five years of age account for approximately one-third of these reported fatalities. For all age categories, more males died from window falls than females.

To help prevent injuries and tragedies, CPSC recommends the following safety tips:

- * Safeguard your children by using window guards or window stops.
- * Install window guards to prevent children from falling out of windows. (For windows on the 6th floor and below, install window guards that adults and older children can open easily in case of fire.)
- * Install window stops so that windows open no more than 4 inches.
- * Never depend on screens to keep children from falling out of windows.
- * Whenever possible, open windows from the top -- not the bottom.
- * Keep furniture away from windows, to discourage children from climbing near windows.

To see this release on CPSC's web site, please go to:
<http://www.cpsc.gov/cpsc/pub/prerelease/prhtml08/08270.html>

Code issues are assigned to the CTC by the ICC Board as "areas of study". Information on the CTC, including: meeting agendas; minutes; reports; resource documents; presentations; and all other materials developed in conjunction with the CTC effort can be downloaded from the following website: <http://www.iccsafe.org/cs/cc/ctc/index.html>. Since its inception in April/2005, the CTC has held fifteen meetings - all open to the public. This public comment is a result of the CTC's investigation of the area of study entitled "Child Window Safety". The CTC web page for this area of study is: <http://www.iccsafe.org/cs/cc/ctc/window.html>

Public Comment 2:

Paul Heilstedt, PE, FAIA, Chair, representing ICC Code Technology Committee (CTC), requests Approval as Modified by this Public Comment.

Modify proposal as follows:

1405.12.2 Window sills. In Occupancy Groups R-2 and R-3, one- and two-family and multiple-family dwellings, where the opening of the sill portion of an operable window is located more than 72 inches (1829 mm) above the finished grade or other surface below, the lowest part of the clear opening of the window shall be a minimum of 24 inches (610 mm) above the finished floor surface of the room in which the window is located. ~~Glazing between the floor and a height of 24 inches (610 mm) shall be fixed or have openings such that a 4-inch (102 mm) diameter sphere cannot pass through.~~ Operable sections of windows shall not permit openings that allow passage of a 4 inch diameter sphere where such openings are located within 24 inches of the finished floor.

Exceptions:

1. Windows whose openings will not allow a 4-inch diameter (102 mm) sphere to pass through the opening when the opening is in its largest opened position.
2. Openings that are provided with window fall prevention devices that comply with 1405.12.3.
3. Openings that are provided with fall prevention devices that comply with ASTM F 2090 ~~or screens that comply with SMA 6004.~~
4. Windows that are provided with opening limiting devices that comply with Section 1405.12.4.

(Portions of proposal not shown remain unchanged)

Commenter's Reason: The purpose of this public comment is two fold: to clarify the language dealing with glazing below the 24 inch height and to remove the reference to the proposed new standard.

Glazing below the 24 inch threshold is a hazard only where the glazing includes an operable section. The change to R6132 in the IRC and 1405.12.2 in the IBC clarifies the application of this section to only operable sections.

The proposed reference to the SMA standard is proposed for deletion in Exception 3 in both codes. While the SMA is indeed a screen standard, it has been brought to the attention of the CTC that the standard was never intended to regulate screens for the purpose of providing a barrier to children when placed in a window.

The hazards associated with child window falls can not be understated as evidenced by the following CPSC Press release dated May 15, 2008:

NEWS from CPSC
U.S. Consumer Product Safety Commission
Office of Information and Public Affairs Washington, DC 20207
FOR IMMEDIATE RELEASE
May 15, 2008
Release #08-270
CPSC Hotline: (800) 638-2772
CPSC Media Contact: (301) 504-7908
Window Falls Prompts CPSC to Issue Warning

WASHINGTON, D.C. - With the arrival of the warmer spring weather, families across the nation are opening their windows to let the fresh air in. This pleasant feeling can quickly turn tragic in households with small children. In recent weeks, several children have fallen from windows. The U.S. Consumer Product Safety Commission is warning parents and caregivers to take precautions to keep children from falling from windows.

"CPSC staff is aware of at least 18 falls from windows through media reports, including two deaths, involving small children since April," said CPSC Acting Chairman Nancy Nord. "We are issuing this warning so parents will take the necessary steps to prevent these incidents from happening."

These deaths and injuries frequently occur when kids push themselves against window screens or climb onto furniture located next to an open window.

From 2002-2004, CPSC staff received an average of 25 reports a year of fatalities associated with falls from windows. Children younger than five years of age account for approximately one-third of these reported fatalities. For all age categories, more males died from window falls than females.

To help prevent injuries and tragedies, CPSC recommends the following safety tips:

- * Safeguard your children by using window guards or window stops.
- * Install window guards to prevent children from falling out of windows. (For windows on the 6th floor and below, install window guards that adults and older children can open easily in case of fire.)
- * Install window stops so that windows open no more than 4 inches.
- * Never depend on screens to keep children from falling out of windows.
- * Whenever possible, open windows from the top -- not the bottom.
- * Keep furniture away from windows, to discourage children from climbing near windows.

To see this release on CPSC's web site, please go to:

<http://www.cpsc.gov/cpsc/pub/prerelease/prhtml08/08270.html>

Code issues are assigned to the CTC by the ICC Board as "areas of study". Information on the CTC, including: meeting agendas; minutes; reports; resource documents; presentations; and all other materials developed in conjunction with the CTC effort can be downloaded from the following website: <http://www.iccsafe.org/cs/cc/ctc/index.html>. Since its inception in April/2005, the CTC has held fifteen meetings - all open to the public. This public comment is a result of the CTC's investigation of the area of study entitled "Child Window Safety". The CTC web page for this area of study is: <http://www.iccsafe.org/cs/cc/ctc/window.html>

Public Comment 3:

Paul Heilstedt, PE, FAIA, Chair, representing ICC Code Technology Committee (CTC), requests Approval as Modified by this Public Comment.

Modify proposal as follows:

1405.12.2 Window sills. In Occupancy Groups R-2 and R-3, one- and two-family and multiple-family dwellings, where the opening of the sill portion of an operable window is located more than 72 inches (1829 mm) above the finished grade or other surface below, the lowest part of the clear opening of the window shall be a minimum of 24 inches (610 mm) above the finished floor surface of the room in which the window is located. Glazing between the floor and a height of 24 inches (610 mm) shall be fixed or have openings such that a 4-inch (102 mm) diameter sphere cannot pass through.

Exceptions:

1. Windows whose openings will not allow a 4-inch diameter (102 mm) sphere to pass through the opening when the opening is in its largest opened position.
2. Openings that are provided with window fall prevention devices that comply with 1405.12.3.
3. Openings that are provided with fall prevention devices that comply with ASTM F 2090 or screens that comply with SMA 6001.
4. Windows that are provided with opening limiting devices that comply with Section 1405.12.4.

1405.12.4 Window opening limiting control devices. When required elsewhere in this code, window opening limiting control devices shall comply with the provisions of ~~this section~~ ASTM F2090.

~~**1405.12.4.1 General requirements.** Window opening limiting devices shall be self-acting and shall be positioned so as to prohibit the free passage of a 4.0 in. (102 mm) diameter rigid sphere through the window opening when the window opening limiting device is installed in accordance with the manufacturer's instructions.~~

~~1405.12.4.2 Operation for emergency escape. Window opening limiting devices shall be designed with release mechanisms to allow for emergency escape through the window opening without the need for keys, tools or special knowledge. Window opening limiting devices shall comply with all of the following:~~

- ~~1. Release of the window opening limiting device shall require no more than 15 lbf (66 N) of force.~~
- ~~2. The window opening limiting device release mechanism shall operate properly in all types of weather.~~
- ~~3. Window opening limiting devices shall have their release mechanisms clearly identified for proper use in an emergency.~~
- ~~4. The window opening limiting device shall not reduce the minimum net clear opening area of the window unit below what is required by Section R310.1.1 of the code.~~

(Portions of proposal not shown remain unchanged)

Commenter's Reason: The IBC and IRC currently reference ASTM F2090 -1001a entitled "Specification for Window Fall Prevention Devices with Emergency Escape (Egress) Release Mechanisms" as an exception for the minimum sill height requirements in the code. As referenced, the scope of the current version addresses only window fall prevention devices. However, the standard is currently being updated to address window opening control devices. In anticipation of the update being completed by the 2008 Final Action Hearings, the CTC is proposing that the text as proposed which was intended to provide performance criteria for such devices be replaced by the industry standard which comprehensively addresses such devices. It should be noted that as of the submission of this public comment, the status of the update process is one of the standard being revised based on previous committee ballots. If the standard is not completed, this public comment will not be pursued at the hearings.

The hazards associated with child window falls can not be understated as evidenced by the following CPSC Press release dated May 15, 2008:

NEWS from CPSC
U.S. Consumer Product Safety Commission
Office of Information and Public Affairs Washington, DC 20207
FOR IMMEDIATE RELEASE
May 15, 2008
Release #08-270
CPSC Hotline: (800) 638-2772
CPSC Media Contact: (301) 504-7908

Window Falls Prompts CPSC to Issue Warning

WASHINGTON, D.C. - With the arrival of the warmer spring weather, families across the nation are opening their windows to let the fresh air in. This pleasant feeling can quickly turn tragic in households with small children. In recent weeks, several children have fallen from windows. The U.S. Consumer Product Safety Commission is warning parents and caregivers to take precautions to keep children from falling from windows.

"CPSC staff is aware of at least 18 falls from windows through media reports, including two deaths, involving small children since April," said CPSC Acting Chairman Nancy Nord. "We are issuing this warning so parents will take the necessary steps to prevent these incidents from happening."

These deaths and injuries frequently occur when kids push themselves against window screens or climb onto furniture located next to an open window.

From 2002-2004, CPSC staff received an average of 25 reports a year of fatalities associated with falls from windows. Children younger than five years of age account for approximately one-third of these reported fatalities. For all age categories, more males died from window falls than females.

To help prevent injuries and tragedies, CPSC recommends the following safety tips:

- * Safeguard your children by using window guards or window stops.
- * Install window guards to prevent children from falling out of windows. (For windows on the 6th floor and below, install window guards that adults and older children can open easily in case of fire.)
- * Install window stops so that windows open no more than 4 inches.
- * Never depend on screens to keep children from falling out of windows.
- * Whenever possible, open windows from the top -- not the bottom.
- * Keep furniture away from windows, to discourage children from climbing near windows.

To see this release on CPSC's web site, please go to:
<http://www.cpsc.gov/cpsc/pub/prerel/prhtml08/08270.html>

Code issues are assigned to the CTC by the ICC Board as "areas of study". Information on the CTC, including: meeting agendas; minutes; reports; resource documents; presentations; and all other materials developed in conjunction with the CTC effort can be downloaded from the following website: <http://www.iccsafe.org/cs/cc/ctc/index.html>. Since its inception in April/2005, the CTC has held fifteen meetings - all open to the public. This public comment is a result of the CTC's investigation of the area of study entitled "Child Window Safety". The CTC web page for this area of study is: <http://www.iccsafe.org/cs/cc/ctc/window.html>

Final Action: AS AM AMPC____ D

RB174-07/08, Part I

R613.2

Proposed Change as Submitted:

Proponent: Michael D. Fischer, The Kellen Company, representing the Window and Door Manufacturers Association

PART I – IRC

Delete and substitute as follows:

~~**R613.2 Window sills.** In dwelling units, where the opening of an operable window is located more than 72 inches (1829 mm) above the finished grade or surface below, the lowest part of the clear opening of the window shall be a minimum of 24 inches (610 mm) above the finished floor of the room in which the window is located. Glazing between the floor and 24 inches (610 mm) shall be fixed or have openings through which a 4-inch diameter (102 mm) sphere cannot pass.~~

Exceptions:

- ~~1. Windows whose openings will not allow a 4-inch diameter (102 mm) sphere to pass through the opening when the opening is in its largest opened position.~~
- ~~2. Openings that are provided with window guards that comply with ASTM F 2006 or F 2090.~~

R613.2 Window fall prevention devices. Window fall prevention devices and window guards, where provided, shall comply with the requirements of ASTM F 2090.

Reason: The 2006 IRC and IBC contain a newly adopted requirement for minimum sill heights in windows located more than 72" above grade as a means to prevent child falls through open windows. During the consideration of this proposal over several code cycles, WDMA expressed dismay with the lack of technical substantiation that demonstrated any positive impact of this requirement on the number of child window falls. In fact, WDMA's opposition was due in large part to concerns about the unintended consequences such a requirement could have on fire safety. Despite objections from numerous parties, the ICC assembly approved the minimum sill height. During the committee hearings, the IRC B/E committee passed a resolution asking for the creation of a study group of ICC that would study the issue of child falls in an attempt to take a serious look at the problem and recommend solutions to improve child safety. The ICC Board took no action on that resolution until after the completion of the 2004-5 code development process. Since that time, the ICC Code Technology Committee was tasked with the responsibility to study the problem of child window falls, gather statistical data, consider associate factors and develop recommended actions. The CTC appointed a study group in January of 2007, and created a scope and objective document, outlining the work plan of the study group. WDMA believes that the work of the CTC window safety study group should have been commissioned and completed before adopting a code requirement that has the potential for negative impact on life safety.

The existing language is flawed. The text fails to specify that it is the lowest portion of an operable window as the point at which the measurement above grade is taken. Under that scoping error, a 6 foot tall casement window installed on a slab-on-grade foundation, with a sill height of 6 inches and located 16 inches above grade would have some of the operable portion located more than 72" above grade, and be subject to the minimum sill height. For this and other reasons, including the lack of technical justification for the sill height requirement, many state jurisdictions have chosen not to include the sill height minimum during adoption of the 2006 IBC and IRC. The more thorough review of the technical issues that is part of many state adoption processes resulted in careful consideration and removal of the requirement. This proposal leaves the requirement that window fall prevention devices and window guards, if furnished, meet consensus standards developed by ASTM and currently referenced in the IRC and IBC.

The addition of the exception provides clear direction on the appropriate scope of the referenced standards to ensure that all guards or devices installed on windows at 75 or below be releasable to allow escape or rescue.

Cost Impact: The code change proposal will not increase the cost of construction.

PART I – IRC

Committee Action:

Disapproved

Committee Reason: This proposal would remove, without technical justification, the minimum window sill height that this committee approved during a previous code cycle. Also, the update of the standard has not been completed.

Assembly Action:

None

Individual Consideration Agenda

This item is on the agenda for individual consideration because a public comment was submitted.

Public Comment:

Michael D. Fischer, The Kellen Company, representing the Window and Door Manufacturers Association, requests Approval as Submitted.

Commenter's Reason: The committee reason for disapproval states that there is no technical justification to remove the minimum sill height requirement. That is ironic given the total lack of data that supports setting a minimum sill heights as a solution to preventing child falls, and that the impact of this requirement to home fire safety will be a reduction in the average size of emergency escape and rescue openings. No attempt has ever been made to demonstrate that reducing the size of millions and millions of windows in our nation's housing stock will not contribute to more residential fire deaths.

The current language is technically flawed. The requirement that the lowest operable portion of the window (see ICC 2006 Commentary excerpt below) is the dimension point that triggers the sill height minimum means that many windows in single story homes are required to meet minimum sill height requirements. (see reason statement for original proposal)

- ❖ This section is not applicable to fixed or stationary windows. If any part of the clear opening area of an operable window is located more than 72 inches (1829 mm) above the finished grade, this section requires that the lowest part of the clear opening be at least 24 inches (610 mm) above the floor surface of the room in which it is located. Windows may be located less than 24 inches (610 mm) above the interior floor surface only if they meet any one of the following criteria: 1) are fixed, 2) are located 72 inches (1829 mm) or less above grade, 3) have openings which will not allow passage of a 4 inch (102 mm) diameter sphere, or 4) are equipped with guards in accordance with ASTM F 2006 or F 2090. ASTM F 2090 addresses window fall prevention devices specifically associated with emergency escape and rescue openings, while ASTM F 2006 addresses devices at non-emergency escape and rescue openings.

Most importantly, a review of child fall data from the Denver, Colorado area shows that child falls in Denver are increasing. This despite the fact that the CPSC reports a reduction on injuries and deaths from child window falls and that annual deaths to children ages 0-9 have been cut by more than half over the past several decades. Meanwhile, Denver is the only area in the US that has had a minimum sill height requirement of 21 inches in place for at least the past decade and a half. Proponents of minimum sill heights state that it will reduce child window fall deaths and injuries; yet the Denver data does not support that contention. This information was presented to the ICC CTC at the convening of the window fall study group, yet the committee chose to ignore the fact that the Denver experience suggests that sill height is not the answer, and in fact sill height minimums in Denver are accompanied by more children suffering severe injuries.

Review of Trauma Visits Related to Child Window Falls in the Denver, CO MSA

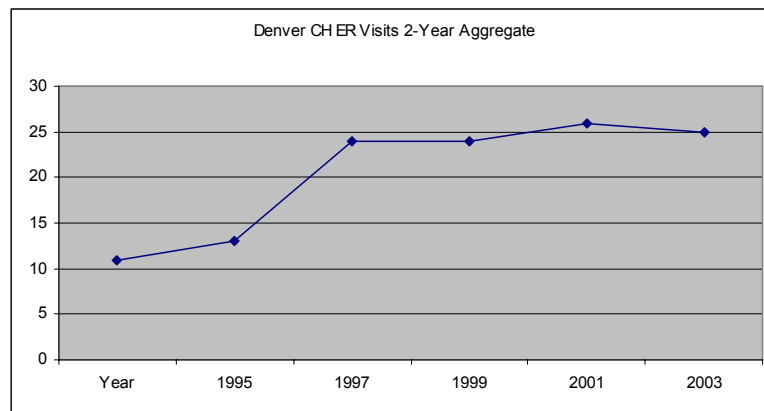

Source: Denver Children's Hospital, Trauma Center Coordinator

The CPSC reports that child window fall deaths have decreased over the past several decades.

Average annual fall deaths for ages 0-9:

1980-1991:	32.5
1992-1993:	24.0
1994-2000:	14.4

Source: CPSC and NEISS data

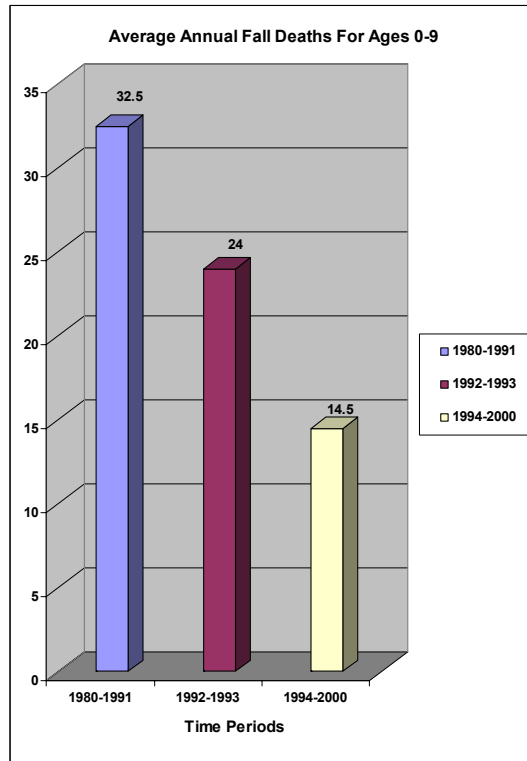

Final Action: AS AM AMPC___ D

RB174-07/08, Part II IBC 1405.12.2

Proposed Change as Submitted:

Proponent: Michael D. Fischer, The Kellen Company, representing the Window and Door Manufacturers Association

PART II – IBC FIRE SAFETY

Delete and substitute as follows:

~~**1405.12.2 Window sills.** In Occupancy Groups R-2 and R-3, one- and two-family and multiple-family dwellings, where the opening of the sill portion of an operable window is located more than 72 inches (1829 mm) above the finished grade or other surface below, the lowest part of the clear opening of the window shall be a minimum of 24 inches (610 mm) above the finished floor surface of the room in which the window is located. Glazing between the floor and a height of 24 inches (610 mm) shall be fixed or have openings such that a 4-inch (102 mm) diameter sphere cannot pass.~~

~~**Exception:** Openings that are provided with window guards that comply with ASTM F 2006 or F 2090.~~

~~**1405.12.2 Window fall prevention devices.** Window fall prevention devices and window guards, where provided, shall comply with the requirements of ASTM F 2090.~~

~~**Exception:** Window fall prevention devices and window guards provided in windows where the lowest operable portion of the window is greater than 75 feet above adjacent grade or surface shall be permitted to comply with ASTM F 2006.~~

Reason: The 2006 IRC and IBC contain a newly adopted requirement for minimum sill heights in windows located more than 72" above grade as a means to prevent child falls through open windows. During the consideration of this proposal over several code cycles, WDMA expressed dismay with the lack of technical substantiation that demonstrated any positive impact of this requirement on the number of child window falls. In

fact, WDMA's opposition was due in large part to concerns about the unintended consequences such a requirement could have on fire safety. Despite objections from numerous parties, the ICC assembly approved the minimum sill height. During the committee hearings, the IRC B/E committee passed a resolution asking for the creation of a study group of ICC that would study the issue of child falls in an attempt to take a serious look at the problem and recommend solutions to improve child safety. The ICC Board took no action on that resolution until after the completion of the 2004-5 code development process. Since that time, the ICC Code Technology Committee was tasked with the responsibility to study the problem of child window falls, gather statistical data, consider associate factors and develop recommended actions. The CTC appointed a study group in January of 2007, and created a scope and objective document, outlining the work plan of the study group. WDMA believes that the work of the CTC window safety study group should have been commissioned and completed before adopting a code requirement that has the potential for negative impact on life safety.

The existing language is flawed. The text fails to specify that it is the lowest portion of an operable window as the point at which the measurement above grade is taken. Under that scoping error, a 6 foot tall casement window installed on a slab-on-grade foundation, with a sill height of 6 inches and located 16 inches above grade would have some of the operable portion located more than 72" above grade, and be subject to the minimum sill height. For this and other reasons, including the lack of technical justification for the sill height requirement, many state jurisdictions have chosen not to include the sill height minimum during adoption of the 2006 IBC and IRC. The more thorough review of the technical issues that is part of many state adoption processes resulted in careful consideration and removal of the requirement. This proposal leaves the requirement that window fall prevention devices and window guards, if furnished, meet consensus standards developed by ASTM and currently referenced in the IRC and IBC.

The addition of the exception provides clear direction on the appropriate scope of the referenced standards to ensure that all guards or devices installed on windows at 75 or below be releasable to allow escape or rescue.

Cost Impact: The code change proposal will not increase the cost of construction.

Committee Action:

Disapproved

Committee Reason: The committee agreed that based on lack of technical justification to remove the sill height requirements from the code, they should remain as currently written. Further, the committee suggested that the proponent coordinate with the efforts of the ICC Code Technology Committee in their efforts. Lastly, this action is consistent with the IRC Committees action on RB174-07/08 Part I.

Assembly Action:

None

Individual Consideration Agenda

This item is on the agenda for individual consideration because a public comment was submitted.

Public Comment:

Michael D. Fischer, The Kellen Company, representing the Window and Door Manufacturers Association, requests Approval as Submitted.

Commenter's Reason: The committee reason for disapproval states that there is no technical justification to remove the minimum sill height requirement. That is ironic given the total lack of data that supports setting a minimum sill heights as a solution to preventing child falls, and that the impact of this requirement to home fire safety will be a reduction in the average size of emergency escape and rescue openings. No attempt has ever been made to demonstrate that reducing the size of millions and millions of windows in our nation's housing stock will not contribute to more residential fire deaths.

The current language is technically flawed. The requirement that the lowest operable portion of the window (see ICC 2006 Commentary excerpt below) is the dimension point that triggers the sill height minimum means that many windows in single story homes are required to meet minimum sill height requirements. (see reason statement for original proposal)

- ❖ This section is not applicable to fixed or stationary windows. If any part of the clear opening area of an operable window is located more than 72 inches (1829 mm) above the finished grade, this section requires that the lowest part of the clear opening be at least 24 inches (610 mm) above the floor surface of the room in which it is located. Windows may be located less than 24 inches (610 mm) above the interior floor surface only if they meet any one of the following criteria: 1) are fixed, 2) are located 72 inches (1829 mm) or less above grade, 3) have openings which will not allow passage of a 4 inch (102 mm) diameter sphere, or 4) are equipped with guards in accordance with ASTM F 2006 or F 2090. ASTM F 2090 addresses window fall prevention devices specifically associated with emergency escape and rescue openings, while ASTM F 2006 addresses devices at non-emergency escape and rescue openings.

Most importantly, a review of child fall data from the Denver, Colorado area shows that child falls in Denver are increasing. This despite the fact that the CPSC reports a reduction on injuries and deaths from child window falls and that annual deaths to children ages 0-9 have been cut by more than half over the past several decades. Meanwhile, Denver is the only area in the US that has had a minimum sill height requirement of 21 inches in place for at least the past decade and a half. Proponents of minimum sill heights state that it will reduce child window fall deaths and injuries; yet the Denver data does not support that contention. This information was presented to the ICC CTC at the convening of the window fall study group, yet the committee chose to ignore the fact that the Denver experience suggests that sill height is not the answer, and in fact sill height minimums in Denver are accompanied by more children suffering severe injuries.

Review of Trauma Visits Related to Child Window Falls in the Denver, CO MSA

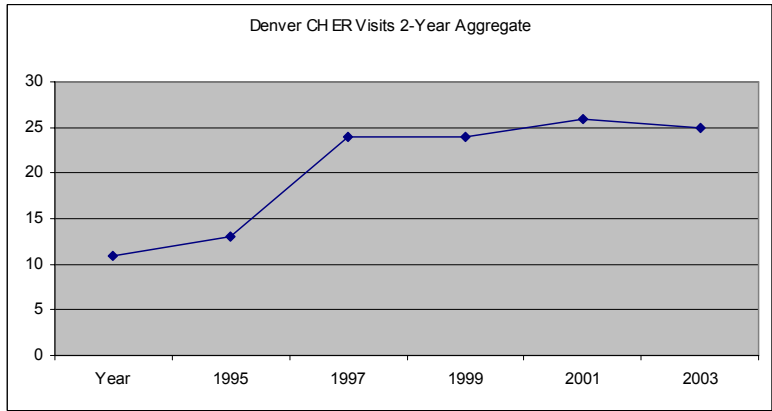

Source: Denver Children's Hospital, Trauma Center Coordinator

The CPSC reports that child window fall deaths have decreased over the past several decades.

Average annual fall deaths for ages 0-9:

1980-1991:	32.5
1992-1993:	24.0
1994-2000:	14.4

Source: CPSC and NEISS data

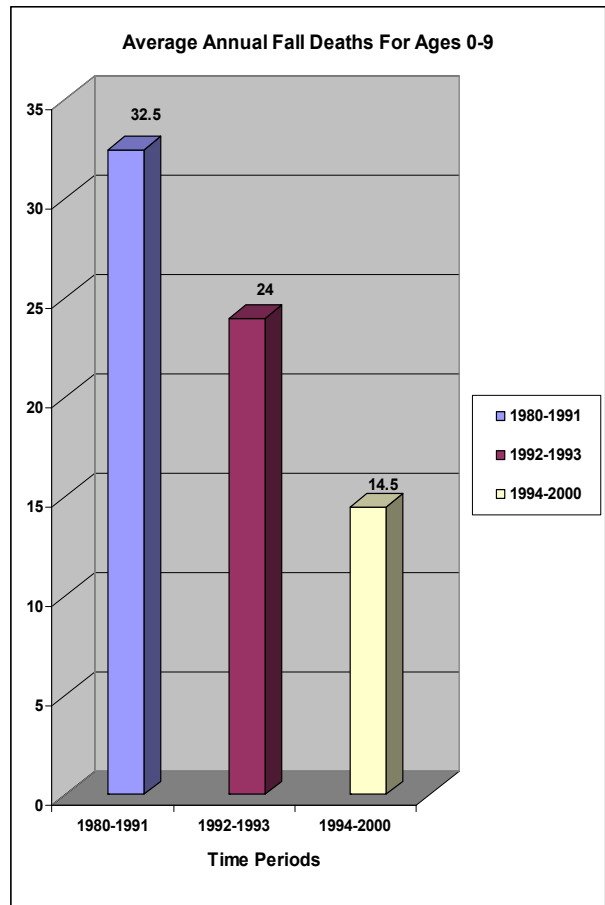

Final Action: AS AM AMPC___ D

RB184-07/08

R702.4.2, Chapter 43 (New)

Proposed Change as Submitted: Barry Reid, Georgia-Pacific Gypsum LLC

Proponent: Barry Reid, Georgia-Pacific Gypsum LLC

1. Revise as follows:

R702.4.2 (Supp) Fiber-cement, fiber-mat reinforced cement, coated glass mat gypsum backers, glass mat water-resistant gypsum panels and fiber-reinforced gypsum backers. Fiber-cement, fiber-mat reinforced cement, coated glass mat gypsum backers, glass mat water-resistant gypsum panels, or fiber-reinforced gypsum backers in compliance with ASTM C 1288, C 1325, C 1178, C 1658 or C 1278, respectively, and installed in accordance with manufacturers' recommendations shall be used as backers for wall tile in tub and shower areas and wall panels in shower areas.

2. Add standard to Chapter 43 as follows:

ASTM

C 1658 Standard Specification for Glass Mat Gypsum Panels

Reason: The purpose of this proposal is to add an ASTM material standard for current provisions of the IRC (IRC) The change to section R702.4.2 provides more options of materials standards appropriate for use as a backer for wall tile in tub and shower areas and wall panels in shower areas. The current code provisions exclude an ASTM product standard recognized in the industry as a water resistant gypsum backing board. Within ASTM C 1658 Section 7.1 is material manufactured for use as a glass mat water resistant gypsum panel.

A comparison of ASTM Standard Specifications for C 1658 and C1278 products reveals that C 1658, Section 7, product physical properties, for use as a water resistant gypsum backer board, meet those of C 1278 in water resistance and surface water absorption.

ASTM C 1658

1.1.3 Glass mat water resistant gypsum panel

7. Physical Properties of Glass Mat Water- Resistant Gypsum Panel

ASTM C 1278

6.1 Physical Properties of Water-Resistant Fiber-Reinforced Gypsum Backing Panels

Coated has been added to the title of standard ASTM C 1178

Cost Impact: The code change proposal will not increase the cost of construction.

Analysis: Review of proposed new standard ASTM C 1658/C 1658M-06 indicated that, in the opinion of ICC Staff, the standard did comply with ICC standards criteria.

Committee Action:

Approved as Submitted

Committee Reason: This change adds glass mat water-resistant gypsum panels for use as backing for wall tile. ASTM Standard for the new material is added.

Assembly Action:

None

Individual Consideration Agenda

This item is on the agenda for individual consideration because public comments were submitted.

Public Comment 1:

Bart Bettiga, National Tile Contractors Association, representing the Board of Directors, requests Disapproval.

Commenter's Reason: The National Tile Contractors Association has not been presented with any test data currently to consider accepting the proposed changes submitted by Georgia Pacific Corporation to code RB 184-07/08 in section R702.4.2, Chapter 43. As a contractor association and strong voice in the tile industry, we are opposed to including products with gypsum without proper test data to support their long term success for areas exposed to moisture, such as bathtubs, showers, tub decks, etc. The proposed changes to the code currently has not allowed our organization, either independently or through our association with the tile industry, to be subjected to this test data. We believe that this change is premature until our industry can examine the test data and compare it to other approved products currently accepted in the code. There is currently proposed language in our industry to eliminate the use of gypsum based products in wet areas. Clearly, this proposed code revision

contradicts what our industry is saying. We are open to reviewing the test data to determine if the products that fit into the category for proposed revision compare favorably with products already approved, but until we are given the opportunity to see this data firsthand, we are strongly opposed to this code revision.

Public Comment 2:

Olene Bigelow, International Masonry Institute, requests Disapproval.

Commenter's Reason: This code change which will allow the use of glass mat water-resistant gypsum panels in wet areas should be disapproved for the following reasons:

1. There is no long-term testing available for these products that are being proposed for use as a tile backer in wet areas. The previous use of a similar material (Green Board) was removed from the code because its performance was inferior to a cementitious backer board. Many showers did not even last 10 years with the similar material because it became brittle and mold laden and ultimately failed.
2. This proposed material has a gypsum core. The Gypsum Association representative to the ANSI Accredited Standards Committee on Ceramic Tile A108 asked that all references to gypsum board products be removed from the ANSI A108 American National Standards Specifications for the Installation of Ceramic Tile for all wet area installations during the May, 2008 meeting of the Committee. The Committee voted to remove those materials from the standard. However, the proposed revisions to the standard have not yet been sent out to letter ballot as of the date of submittal of this Public Comment.
3. This product does not have manufacturer instructions that include wet area installations.
4. To the best of our knowledge, we do not know of any projects that have been subjected to water and survived for at least 10 years with this product as a back up for ceramic tile in wet areas.
5. This panel is not a structural panel and may not have sufficient strength to hold the weight of some large module porcelain tiles over a long period of time in wet areas. Adequate testing to prove its efficacy in these conditions has not been conducted.

This type of material should not be allowed as it has not yet been proven to be resistant to moisture and mold and other materials are available which perform better and are more cost-effective. We are requesting disapproval of Code Change RB184-07/08 which will allow glass mat water-resistant gypsum panels to be used in wet areas if this Public Comment is not successful. Therefore, this Public Comment must be approved by the ICC Class A voting members to avoid this problem.

Public Comment 3:

Michael Blades, National Gypsum Company, requests Disapproval.

Commenter's Reason: The proposed action is to allow products meeting ASTM C 1658 to be used as a tile backer in wet areas. This product has no history of ever being used in this manner. The ASTM standard does not have any testing related to tile bond strength, mold resistance, or warm water resistance. The nail pull test does not test under wet conditions, only dry.

No tile related organization has approved this type of product for this type of use as of this date. This includes the Tile Council of North America, the National Tile Contractors Association, or the American National Standard Specifications for the Installation of Ceramic Tile (ANSI).

Before a product standard is approved for use as a tile backer in wet areas it should include testing for tile bond, wet nail pull, warm water resistance, and mold resistance so as to avoid issues in actual use. Please consider disapproving the RB184 proposal and allow ASTM the time to revise the ASTM C 1658 standard to include these types of tests so that product performance meets the code expectations.

Public Comment 4:

Jose Manuel Estrada, USG Corporation, requests Disapproval.

Commenter's Reason: The proposal aims to include an ASTM material standard for current provisions of the IRC, under the explanation of: Providing more options of material standards, appropriate for use as backer for wall tile in tub and shower areas and wall panels in shower areas.

During the 03/04 code cycle, water-resistant gypsum panels were removed from the IRC to be used as tile backer for tub and shower areas and as wall panels in shower areas. Subsequently, at a Tile Council of North America (TCNA) hearing, to determine the appropriate substrates, three concerns were given as part of the testimony seen as sources for failure when exposed to water, the ability (a) for the paper or glass mat to delaminate from the core, (b) absorb water, and (c) transmit it in to the cavity; resulted in the elimination of water-resistant gypsum panels from the areas previously mentioned.

Following these 3 concerns / criteria / limitations:

1. Paper or Glass-mat delamination
2. Water-resistance requirements (based from ASTM C 1396 Section, 7.1.4).
3. Water-transmission through the panel (based on an ASTM Test procedure D 4068 A2. [Hydrostatic Pressure Test]).

Products will have to meet these criteria in order to be installed for use as tile backer for wall tile in tub and shower areas and wall panels in shower areas. Looking at the already approved materials complying with ASTM C 1288 and C 1325 both are Cement-base products which will not decay with exposure moisture. For products complying with ASTM C1178 and 1278, both gypsum base products, the first, coated glass mat gypsum backer, and second, fiber-reinforced gypsum backer, are gypsum based and would have to comply with the three previously mentioned concerns / criteria.

The proponent draws a relation, between the similarities in water-resistance of ASTM C 1278 and C 1658, however it does omit reference to its water-transmission properties, when subjected to the Hydrostatic Pressure Test. It is when subjected to this particular test where we see that the product standard C 1658 is not suitable to be installed as a tile backer for tub and shower areas. The failure occurs due to the lack of a coating on the glass mat, therefore allowing for water to pass through the product, potentially saturating the gypsum core, resulting on delamination of the glass-mat face.

Final Action: AS AM AMPC____ D

RB187-07/08

R703.2, R703.2.1 (New), R703.2.2 (New)

Proposed Change as Submitted:

Proponent: Joseph W. Lstiburek, Building Science Corporation

1. Revise as follows:

R703.2 Water-resistive barrier. A water resistive barrier shall be applied over studs or sheathing of all exterior walls

R703.2.1 Felt or other approved material One layer of No. 15 asphalt felt, free from holes and breaks, complying with ASTM D 226 for Type 1 felt or other approved water-resistive barrier shall be applied over studs or sheathing of all exterior walls. Such felt or material shall be applied horizontally, with the upper layer lapped over the lower layer not less than 2 inches (51 mm). Where joints occur, felt shall be lapped not less than 6 inches (152 mm). The felt or other approved material shall be continuous to the top of walls and terminated at penetrations and building appendages in a manner to meet the requirements of the exterior wall envelope as described in Section R703.1.

2. Add new text as follows:

R703.2.2 Insulating sheathing Insulating sheathing as a water resistive barrier shall be continuous to the top of the walls and flashed at penetrations and building appendages in a manner to meet the requirements of the exterior wall envelope as described in Section R703.8 and installed as follows:

1. All horizontal joints flashed with approved corrosion-resistive flashings extending not less than 2 inches (51 mm) behind the sheathing above the joint and overlapping sheathing below the joint by not less than 2 inches (51 mm), and
2. All vertical joints installed as detailed in assembly testing in accordance with ASTM E 331 under the following conditions:
 - 2.1. Test assemblies shall be at least 4 feet wide by 8 feet high (1219 mm by 2438 mm) in size and shall include at least one vertical, unbacked joint representative of normal installation methods.
 - 2.2. The assemblies shall be tested without exterior wall coverings.
 - 2.3. The test assemblies shall be tested at a minimum differential pressure of 3.0 psf (0.15 kN/m²).
 - 2.4. The test assemblies shall be subjected to a minimum test exposure duration of 15 minutes.
 - 2.5. Conditions of Acceptance: Water shall not penetrate to the unexposed face of the insulating sheathing.

Exception: Omission of the water-resistive barrier is permitted in the following situations:

1. In detached accessory buildings.
2. Under exterior wall finish materials as permitted in Table R703.4.
3. Under paperbacked stucco lath when the paper backing is an approved weather-resistive sheathing paper.

Reason: The purpose of this code change proposal is to permit insulating sheathing use as a water resistive barrier (WRB). This language will prescriptively allow insulating sheathing as alternative to water resistant sheathing paper or felt. Insulating Sheathing as a water resistive barrier gives the builder more code approved WRB options to select from. Section R 703 in the IRC calls for the use of a water resistive barrier behind the exterior veneer in an exterior wall. Section R703.2, in the IRC, outlines the requirements for felt paper used as a water resistive barrier. This code change will define the requirements for insulating sheathing use as a water resistive barrier.

The code currently has grandfathered the use of asphalt felt paper for use a water resistive barrier. This material has a long and distinguished historical track record of successful performance. It is logical to use asphalt felt paper to establish the minimum performance requirement for a water resistive barrier. Consider also that windows typically exceed the performance of asphalt felt paper with respect to water resistance. The code references AAMA/WDMA/CSA 101/I.S.2/A440 for use in determining water penetration resistance of windows, including test methods and conditions to assess such performance. Windows rated for residential use via this standard are assessed using 3 psf (150 Pa) pressure differential. The test requirements proposed in this code change include assessment of the vertical joints by testing using ASTM E 331 at the same pressure differential that is required by windows: 3.0 psf (150Pa). This is a conservative approach, since materials that are known to work as water resistive barriers, such as asphalt felt paper, when incorporated into a wall assembly and tested via these conditions, have not been shown to pass these window performance requirements.

A second conservative feature of this proposal is the test requirement that includes the use of minimum extensions of 2" z-flashing at the horizontal joints. The use of z-flashing at horizontal joints with insulating sheathing provides for superior water management of a wall system. A gravity overlap joint is superior to an adhesive taped joint. Water at a height of 2" corresponds to 10.4 psf (500 Pa). The water pressure tolerance of the horizontal flashing, defined by the 2" required extensions, is clearly a conservative approach for water resistance of the wall assemblies using insulating sheathing as the water resistive barrier. The use of insulating sheathing as water resistant barrier installed with horizontal flashing has been effective in new homes across the country, including homes built under the Building America program.

A third conservative measure that is built into this code change proposal is that worse case scenario requirement of testing the assembly without the exterior cladding. It is recognized by the code that for both walls and windows, cladding or covering increases the water resistance of an assembly.

For many years confusion has existed regarding whether insulating sheathing meets the requirement for a water-resistant barrier. The ICC Evaluation Service developed an "Interim Criteria For Foam Plastic Sheathing Panels Used As Weather-Resistive Barriers" – AC71 that became effective March 1, 2003. This interim criteria, AC71 provides overly strict performance requirements. The specific requirement is a two hour water test using ASTM E-331 with a 6.24 psf (300 Pa) pressure differential, without the presence of a cladding over the insulating sheathing. In comparison, windows need only perform to a 15 minute test at 1/2 the pressure - 150 Pa. The selection of 6.24 psf (300 Pa) pressure differential at 2 hours in the code and in AC-71 was arbitrary and capricious and has no basis in historical experience. It came as a result of a desire to punish the EIFS industry for their failures. It was designed to set a bar so high that EIFS would never again be a problem. Unfortunately this punitive club is being wielded against all assemblies. It was the wrong number for EIFS and it is the wrong number for walls in general. Furthermore, the requirement to have the test specimen tested horizontally is beyond ridiculous as it will cause any flashed joint to fail. Flashed joints are obviously superior to any taped or sealed joint. This particular requirement prevents the use of the most historically successful technical rain control approach for water drainage of horizontally overlapped materials. It effectively bans the use of flashing as a rain control approach, which is outrageous. AC-71 apparently does not understand the difference between a wall, which is by definition vertical, and roof which is not. Testing wall assemblies horizontally is beyond the Pale. The disconnect between reality and the current testing requirements has significant detrimental cost implications and places an artificially high barrier to a new technology that is superior to existing "grandfathered" technologies.

This code proposal calls for the use of effective flashing already specified in the code (Section R 703.8), combined with testing at realistic conditions (ASTM E 331) to allow insulating sheathing use as a water resistive barrier.

Cost Impact: The code change proposal will not increase the cost of construction.

Committee Action:

Approved as Modified

Modify proposal as follows:

R703.2.2 Insulating sheathing Insulating sheathing as a water resistive barrier shall be continuous to the top of the walls and flashed at penetrations and building appendages in a manner to meet the requirements of the exterior wall envelope as described in Section R703.8 and installed as follows:

- ~~1. All horizontal joints flashed with approved corrosion resistive flashings extending not less than 2 inches (51 mm) behind the sheathing above the joint and overlapping sheathing below the joint by not less than 2 inches (51 mm), and~~
- ~~2.1. All horizontal and vertical joints shall be installed as detailed in assembly testing in accordance with ASTM E 331 under the following conditions:~~
 - ~~2.4. 1.1.~~ Test assemblies shall be at least 4 feet wide by 8 feet high (1219 mm by 2438 mm) in size and shall include at least one vertical, unbacked joint representative of normal installation methods.
 - ~~2.2. 1.2.~~ The assemblies shall be tested without exterior wall coverings.
 - ~~2.3. 1.3.~~ The test assemblies shall be tested at a minimum differential pressure of 3.0 psf (0.15 kN/m²).
 - ~~2.4. 1.4.~~ The test assemblies shall be subjected to a minimum test exposure duration of 15 minutes
 - ~~2.5. 1.5.~~ Conditions of Acceptance: Water shall not penetrate to the unexposed face of the insulating sheathing.

Exception: Omission of the water-resistive barrier is permitted in the following situations:

1. In detached accessory buildings.
2. Under exterior wall finish materials as permitted in Table R703.4.
3. Under paperbacked stucco lath when the paper backing is an approved weather-resistive sheathing paper.

Committee Reason: This change adds an alternative water resistive barrier. The modification changes the installation to treat the horizontal and vertical joints the same.

Assembly Action:

None

Individual Consideration Agenda

This item is on the agenda for individual consideration because public comments were submitted.

Public Comment 1:

Joseph W. Lstiburek, Building Science Corporation, requests Approval as Modified by this Public Comment.

Further modify proposal as follows:

R703.2.2 Insulating sheathing Insulating sheathing complying with ASTM C578 or ASTM C1289 installed as a water resistive barrier shall be continuous to the top of the walls and flashed at penetrations and building appendages in a manner to meet the requirements of the exterior wall envelope as described in Section R703.8 and installed as follows:

1. All horizontal and vertical joints shall be installed as detailed in assembly testing in accordance with ASTM E 331 under the following conditions:
 - 1.1. Test assemblies shall be at least 4 feet wide by 8 feet high (1219 mm by 2438 mm) in size and shall include at least one vertical, unbacked joint representative of normal installation methods.

- 1.2. The assemblies shall be tested without exterior wall coverings.
- 1.3. The test assemblies shall be tested at a minimum differential pressure of 3.0 psf (0.15 kN/m²).
- 1.4. The test assemblies shall be subjected to a minimum test exposure duration of 15 minutes
- 1.5. Conditions of Acceptance: Water shall not penetrate to the unexposed face of the insulating sheathing.

Exception: Omission of the water-resistive barrier is permitted in the following situations:

1. In detached accessory buildings.
2. Under exterior wall finish materials as permitted in Table R703.4.
3. Under paperbacked stucco lath when the paper backing is an approved weather-resistive sheathing paper.

(Portions of proposal not shown remain unchanged)

Commenter's Reason: I listened to the committee and industry in-put at the initial action hearings. I agree that it makes sense to clearly define the materials that are covered by this code change, as well as assuring their physical property performance through adding the appropriate ASTM material standards to the code. As such, the material standards for cellular polystyrene foam plastics, ASTM C 578 and cellular polyisocyanurate foam plastics ASTM C 1289 have been added.

Public Comment 2:

Theresa Weston, PhD, DuPont Building Innovations, requests Approval as Modified by this Public Comment.

Further modify proposal as follows:

R703.2.2 Insulating sheathing Insulating sheathing complying with ASTM C578 or ASTM C1289 installed as a water resistive barrier shall be continuous to the top of the walls and flashed at penetrations and building appendages in a manner to meet the requirements of the exterior wall envelope as described in Section R703.8 and installed as follows:

1. All horizontal and vertical joints shall be installed as detailed in assembly testing in accordance with ASTM E 331 under the following conditions:
 - 1.1. Test assemblies shall be at least 4 feet wide by 8 feet high (1219 mm by 2438 mm) in size and shall include at least one vertical and two horizontal unbacked joints representative of normal installation methods.
 - 1.2. The assemblies shall be tested without exterior wall coverings.
 - 1.3. Prior to testing per ASTM E331, wall assemblies shall be exposed to 5 cycles of environmental exposure as follows: 24 hour water spray exposure, and 24 hour heating to 120°F (49°C)
 - ~~1.4.~~ 1.4 The test assemblies shall be tested at a minimum differential pressure of 3.0 psf (0.15 kN/m²).
 - ~~1.5.~~ 1.5 The test assemblies shall be subjected to a minimum test exposure duration of 15 minutes
 - ~~1.6.~~ 1.6 Conditions of Acceptance: Water shall not penetrate to the unexposed face of the insulating sheathing.

Exception: Omission of the water-resistive barrier is permitted in the following situations:

1. In detached accessory buildings.
2. Under exterior wall finish materials as permitted in Table R703.4.
3. Under paperbacked stucco lath when the paper backing is an approved weather-resistive sheathing paper.

Commenter's Reason: The original proposal sought to remove "insulating sheathing" water-resistive from being considered an alternate or other approved material and provide it its own code section. At the Code Committee Hearings, I urged disapproval because this proposal because it significantly decreased the stringency of the evaluation of these types of systems from current practice and created a loophole through which un-tested and previously un-allowed materials would be allowed. Currently plastic foam sheathing is allowed as an alternate material through Section R104.11 and is evaluated for this use by ICC-ES Acceptance Criteria for Foam Plastic Sheathing Panels used as Weather-Resistive Barriers (AC-71).¹

The modification that is proposed by this public comment includes the modifications approved in the Code Committee Hearings with the addition of two modifications which address the most significant flaws in the both the original and Code Committee Hearing modified proposals. The significant flaws addressed are:

- Lack of water-resistive barrier material characterization or definition
- No provision for the durability of sheathing joints.

These flaws and the proposed remedies proposed in this public comment are discussed in more detail below.

Lack of water-resistive barrier material characterization or definition

The original proposal describes only "insulating sheathing" with no accompanying specification or standard. In particular there is no level of water resistance of the base material provided. The term "insulating sheathing" as defined in Ch. 2 of the code requires only an R-value of 2: "insulating sheathing " an insulating board having a minimum thermal resistance of R-2 of the core material." Although testimony at the Code Committee Hearing focused on plastic foam sheathing materials, a search is done for products that describe themselves as "insulating sheathings" include the following products included laminated fibrous board sheathing, asphalt-impregnated fiber board sheathing, expanded polystyrene foam, extruded polystyrene insulation, faced poly-isocyanurate foam, and some radiant barrier materials. Some of these materials function as water-resistive barriers, others do not. The modification addresses this issue by a direct reference to ASTM Standards C578 and C1289, which are currently referenced in the ICC-ES Acceptance Criteria for Foam Plastic Sheathing Panels used as Weather-Resistive Barriers (AC-71).²

No provision for the durability of sheathing joints

The vertical and horizontal joints between individual sheathing panels are critical to the performance of sheathing water-resistive barriers. When felt (the traditional water-resistive barrier) is used, not only are the seams lapped by a minimum of 2 inches, but the seams on the sheathing and water-resistive barrier are staggered so that there is no direct path through the seams of the water-resistive barrier to the edges of the underlying sheathing. Because with insulating sheathing the water-resistive barrier and sheathing are one in the same, any breach of the joints provides a direct path into the wall cavity. Additionally, there will be many more vertical joints with sheathing boards than with the basic felt water resistive barriers.

A review of industry documents shows that foam sheathing panel shrinkage can result in the opening of panel joints and the stress of taped joints ultimately leading to failure:

"XPS and polyisocyanurate have commonly been utilized as a moisture barrier, but recent building science research has shown that these products may not be as dimensionally stable as initially thought. There is some evidence that the insulation boards shrink enough (up to 5/8") that simply taping the joints may not be sufficient to maintain the drainage plane long term." – Energy Efficient and Green Technology Building Template Guide for the State of Maryland, prepared for Maryland Energy Administration – Energy Efficiency Programs by Steven Winter Associates, January 10, 2007

"Builders considering using foam sheathing as a WRB need more than code approval; they also need to be assured that rigid foam products are dimensionally stable enough to shed water dependably." – "Planning for Foam Shrinkage," Energy Design Update, Vol. 26, No. 9, September 2006.

"Insulating sheathing installed as the drainage plane. The final approach would be to use the insulating sheathing as the primary sheathing and drainage plane of the assembly... Proper functioning of this system relies on the adhesion of membrane flashings and housewrap tapes to the face of the insulating sheathing. Membrane flashings and sheathing tapes are difficult to adhere to the surface of EPS and fiberglass faced polyisocyanurate. Foil faced polyisocyanurate and XPS would be more appropriate for this wall type. This is the least expensive system though it also has some increased risk associated with it. With some question as to the long term dimensional stability of insulating sheathing products, this should only be used in areas with limited rainfall and exposure, where rain water management is not as critical." – Baker, Peter, "Incorporating Insulating Sheathing into the Design of the Thermal and Moisture Management System of the Building Enclosure", ACEEE Summer Study on Energy Efficiency in Buildings, August 2006.

"Taped rigid insulation is not allowed as an air barrier in Wisconsin. When some types of insulation boards get colder by 70°F, they can shrink ¼" on all sides. The tape cannot adequately perform under such circumstances." – Air Barrier Update, International Masonry Institute Technology Brief, January 2004.

In our laboratory we conducted some initial tests on the performance of taped insulating sheathing wall assembly which passed the criteria in the proposal after exposure to thermal cycling. Walls assemblies were tested by the ASTM E331 criteria in the proposal, then exposed to 5 cycles of thermal cycling between 120°F and 32°F and retested by the ASTM E331 procedure. The results are shown in the table below.

Sheathing	E331 Performance (15 minutes @ 3 psf)	
	Initial	After Thermal Cycling
#1 (Faced XPS)	Pass	Tape failure on horizontal joint
#2 (Faced EPS)	Pass	Tape failure on horizontal joint
#3(Faced Polyisocyanurate)	Pass	Pass

Sheathing butt joints were observed to enlarge up to 1/8 inch. A typical failure is shown using colored water in the figure below. Loss of tape adhesion resulted in water intrusion behind the tape collecting at and ultimately intruding through the panel joint.

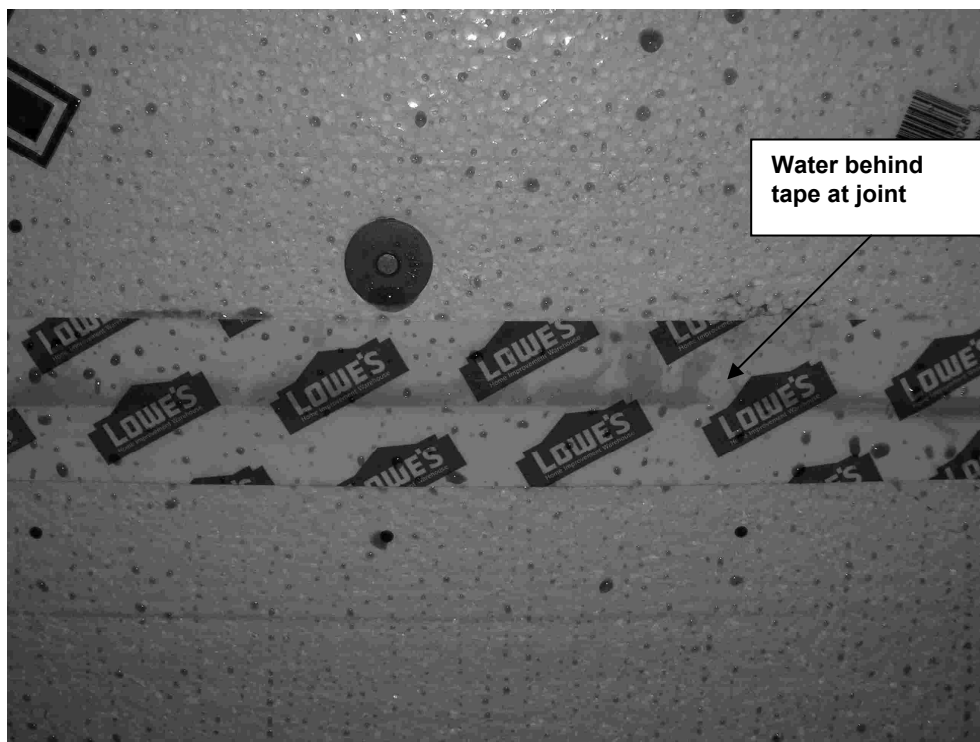

Neither the original and nor the modified proposal contain criteria to test the durability of the sheathing, the tape used in sealing joints, or joint performance. The only test is a 15 minute water resistance test conducted under laboratory conditions. AC71 by contrast has several parts of the criteria which assess the durability of the system. Water resistance of the basic sheathing is measured after exposure to UV light. Water resistance of taped joints is measured after UV light exposure and accelerated aging (25 cycles of 3 hours heating at 120oF, immersion in water for 3 hours and drying at room temperature for 18 hours). To correct the serious flaw in the proposal, the modification proposed in this public comment introduces a pre-stressing step consisting of limited cycles of thermal and moisture exposure prior to water resistance evaluation. The proposed pre-stressing procedure is used in two ICC-ES Acceptance Criteria for sheathing based water-resistive barriers: AC310 (Acceptance Criteria for Water-Resistive Membranes Factory-Bonded to Wood-Based Structural Sheathing, Used as Water-Resistive Barriers) and AC382

(Acceptance Criteria for Laminated Fibrous Board Sheathing Material Used as a Water-Resistive Barrier). The exposure used in AC310 and AC382, although less rigorous than that in AC71 was selected as the pre-stressing step as it was more applicable wall assembly testing such as that specified in the original proposal.

¹ ICC-ES Acceptance Criteria are available on www.icc-es.org.

² Specifically ICC-ES AC71 references Sections 3.4.1 and 3.4.3 of ICC-ES Acceptance Criteria for Foam Plastic Insulation (AC12) which further references ASTM C587 and ASTM C1289.

Final Action: AS AM AMPC____ D

RB189-07/08 Table R703.4

Proposed Change as Submitted:

Proponent: Edward L. Keith, PE, APA- The Engineered Wood Association

Revise table as follows:

**TABLE R703.4 (Supp)
WEATHER-RESISTANT SIDING ATTACHMENT AND MINIMUM THICKNESS**

SIDING MATERIAL	NOMINAL THICKNESS ^a (inches)	JOINT TREATMENT	Water Resistive Barrier Required	Wood or wood structural panel sheathing	Fiberboard sheathing into stud	Gypsum sheathing into stud	Foam plastic sheathing into stud	Direct to studs	Number or spacing of fasteners
Brick veneer ² concrete masonry veneer ²	2 2	Section R703	Yes (Note 1)	See Section R703 and Figure 702.7 ⁹					
Stone veneer	2	Section R703	Yes (Note 1)	See Section R703 and Figure 702.7 ⁹					

a. through k. (No change)

l. ~~When an air space in compliance with Section R703.7.4.2 is provided, a water resistive barrier is not required over a sheathing installed to perform as a water resistive barrier. When a mortar or grout filled air space in compliance with Section R703.7.4.3 is provided, a water resistive sheathing barrier is required over studs or sheathing.~~

(Reletter subsequent notes)

(Portions of table and footnotes not shown remain unchanged)

Reason: The purpose of these code changes is to delete a current provision in the code that is the source for poor building performance in many applications.

The current provisions permits the elimination of weather-resistive sheathing paper behind stone and masonry veneer if a 1" air space is maintained. Historically, the justification for the elimination of weather-resistive sheathing paper was that with a 1-inch air space it was unlikely that mortar squeeze out would span the gap between the masonry veneer and the wall behind, therefore if an air space of 1" is maintained the paper may be eliminated. As it turns out, the elimination of the weather-resistive sheathing paper can cause problems unrelated to the potential mortar squeeze-out:

- With the 1" air space behind the masonry units the mortar squeeze out can and often does fall to the bottom of the gap and makes the very effective moisture bridges that the gap is placed to prevent. This squeeze out that falls to the bottom of the gap can also block weep holes at the bottom which blocks water drainage and reduces or prevents air flow that is supposed to keep the structural wall behind the veneer dry.
- If the masonry wall only extends partially up the wall height, then it is likely that weather-resistive sheathing paper is used on the wall above. One of the purposes of this sheathing paper is to channel water that gets behind the exterior barrier down to the ground. If no paper is required at the lower portion of the wall how does the water from the upper half of the wall get to the ground? While it is possible to accomplish this with flashing, it channels the water over the face of the brick. The same can happen in a two-story house where only the first floor has the veneer.
- In high wind areas, wind can force water in through weep holes and even through porous mortar joints. Masonry veneer is not waterproof! If it were, no air gaps or weather-resistive sheathing paper would be required.
- Many modern windows are designed to channel water around the window frame and permit it to drain out of the bottom of the window. Unless the flashing shown without detail in Figure R703.7, is applied perfectly, there is a high probability that it will end up passing over the unprotected wall below.
- Note that it is the intention of the code to provide a double layer of weather protection between the outside environment and the unprotected framework of the wall. History has shown that stone and masonry veneer in of themselves do not form an adequate weather-resistive barrier without some other form of protection. This used to be a 1/2" air gap, but that didn't work. Now stone or brick veneer with a 1" air space is deemed to be equivalent to a weather resistive barrier. Field performance has shown that air gaps of even 1" in thickness are very difficult to maintain.

•Many builders find it difficult to maintain a 1" air gap due to the constraints of the brick ledge below. Due to this and the other construction issues covered above, a weather-resistive barrier should be required behind brick veneer.

The use of a weather-resistive sheathing paper is an inexpensive way to protect the greatest investment most people will ever make. It is not rational to provide what is essentially an exception for a construction type with a known history of moisture problems when construction details are not followed to the letter. The use of sheathing paper will provide an extra level of protection that this system needs, and will make the veneer weather-resistant barrier system compatible with that used on the rest of the house.

Cost Impact: The code change proposal will slightly increase the cost of construction.

Committee Action:

Approved as Submitted

Committee Reason: The proposal eliminates footnote "I" which may be misleading to indicate that wood structural panel is a water resistive barrier. Also, to be consistent with the committee's action on RB187-07/08.

Assembly Action:

None

Individual Consideration Agenda

This item is on the agenda for individual consideration because a public comment was submitted.

Public Comment:

Gary J. Ehrlich, P.E., National Association of Home Builders (NAHB), requests Disapproval.

Commenter's Reason: The issues raised by the proponent in his reason statement are primarily ones of field practice, rather than an issue of design or detailing. The code should not be used as a vehicle to deal with quality control issues that can be handled through improved code enforcement and improved training of workers.

The proponent indicates a need to particularly detail the structure to resist wind-driven moisture. Not all regions of the country face that issue, particularly in areas that are warm, dry climates. The reason statement suggests the WRB is needed in hurricane-prone regions, but the IRC covers many areas of low-wind hazard (and lower winds in general) where the requirement may be needed. The proponent should submit statistical/technical data to support changing long-established practice on a national basis.

Further, a number of products are available on the market other than housewrap or felt to address the issues raised. For example, MortarNet's line of products, which address the issue of mortar droppings blocking weepholes. Additionally, there are sheathing products on the market, for example Huber, which incorporate a polyethylene film or treated paper WRB as part of the product. Both the proponent's and the committee's reason statements appear to imply that these products, or other products like insulating foam sheathing using taped joints (as approved in RB187), are not sufficient for use as a WRB, and that an independent layer of housewrap or felt is the only acceptable material for use in meeting the requirements of Table R703.4. This proposal therefore does not provide a level playing field for all manufacturers of sheathing and weather-resistant products, and limits builder flexibility not only to meet these requirements, but also increasing energy code requirements.

For these reasons, NAHB asks for your support in disapproving this proposal and overturning the IRC-B/E committee's action.

Final Action: AS AM AMPC___ D

RB195-07/08

Table R703.4, R703.11.2

Proposed Change as Submitted:

Proponent: Jay H. Crandell, PE, ARES Consulting, representing the Foam Sheathing Coalition

1. Revise table as follows:

TABLE R703.4 (Supp)
WEATHER-RESISTANT SIDING ATTACHMENT AND MINIMUM THICKNESS

SIDING MATERIAL	NOMINAL THICKNESS ^a (inches)	JOINT TREATMENT	WATER-RESISTIVE BARRIER REQUIRED	TYPE OF SUPPORTS FOR THE SIDING MATERIAL AND FASTENERS ^{b,c,d}					
				Wood or wood structural panel sheathing	Fiberboard sheathing into stud	Gypsum sheathing into stud	Foam plastic sheathing into stud	Direct to studs	Number of spacing of fasteners
Vinyl siding ^m	0.035	Lap	Yes	0.120 nail (shank) with a .313 head or 16 gauge staple with 3/8 to 1/2-in crown ^{bb,cc}	0.120 nail (shank) with a .313 head or 16 gauge staple with 3/8 to 1/2-in crown ^{bb}	0.120 nail (shank) with a .313 head or 16 gauge staple with 3/8 to 1/2-in crown ^{bb}	Refer to Section R703.11.2 0.120 nail (shank) with a .313 head or 16 gauge staple with 3/8 to 1/2-in crown ^{bb}	Not allowed	16 inches on center or as specified by the manufacturer instructions or test report

(Portions of table and footnotes not shown remain unchanged)

2. Add new text as follows:

R703.11.2 Design Wind Pressure. Where installed over solid sheathing or backing material capable of independently resisting the required wind loads, vinyl siding shall be installed in accordance with Table 703.4 and in accordance with the manufacturer's installation instructions for the applicable design wind suction pressure condition per Tables R301.2(2) and R301.2(3). Where foam plastic sheathing is used as a backing material, the design wind pressure ratings in the vinyl siding manufacturer's installation instructions shall be adjusted in accordance with the following wall assembly conditions:

1. For foam plastic sheathing applied directly over a solid backing material capable of resisting the wind load, the vinyl siding's design wind pressure rating shall be used without adjustment.
2. For foam plastic sheathing with gypsum wallboard or equivalent on interior side of wall, multiply the vinyl siding's design wind pressure rating by 0.39.
3. For foam plastic sheathing without gypsum wallboard or equivalent on interior side of wall or gable roof end framing, multiply the vinyl siding's design wind pressure rating by 0.27.

The adjusted design wind pressure rating for the applicable assembly shall meet or exceed the applicable design wind suction pressure of Tables R301.2(2) and R301.2(3) and shall apply to conditions where design is required in accordance with Section R703.4.

Exception: Where the vinyl siding manufacturer's installation instructions specifically provide a wind pressure rating for installation over foam sheathing, those instructions shall be used in lieu of the above adjustments.

Reason: This code change proposal resolves concerns raised last code cycle with code change proposal RB 250. In response, this proposal establishes a proper basis for vinyl siding applications with foam sheathing by applying appropriate adjustment factors to vinyl siding wind pressure ratings to address this specific assembly condition. Because the vinyl and foam sheathing assembly serve as the primary weather barrier or envelop for the building (when no additional structural sheathing is applied), the vinyl siding pressure rating values have been factored to provide a net safety factor of 2.0 instead of 1.5 as required by ASTM D3679 for applications of vinyl siding over "solid walls". A safety factor of 1.5 is retained in accordance with ASTM D3679 (and other similar standards such as ASTM E330 for envelop components, curtain walls, etc.) when vinyl is used over a solid backing material (e.g., structural sheathing, concrete or masonry wall, foam sheathing applied over or underneath a structural sheathing, etc.). In this case, the solid backing material is designed to independently resist the design wind pressure with or without the presence of vinyl siding and, thus, maintains at least a structural barrier or envelope to protect building contents even in the event of cladding system failure. The adjustments factors employed in this proposal also account for difference in pressure equalization effects addressed in ASTM D3679 Annex A for the specific wall assembly conditions where vinyl siding is used with a foam sheathing backing material. This proposal will significantly improve wind resistance by requiring the use of higher performing vinyl siding products in applications with foam sheathing backing materials.

Cost Impact: The code change proposal will increase the cost of construction.

Committee Action:

Disapproved

Committee Reason: Based on the committee's action on RB194-07/08. The proposed modification was a complete rewrite and did not allow for enough time for review. The proponent should rewrite and bring this back.

Assembly Action:

None

Individual Consideration Agenda

This item is on the agenda for individual consideration because a public comment was submitted.

Public Comment:

Jay H. Crandell, P.E., ARES Consulting, representing Foam Sheathing Coalition, Vinyl Siding Institute (Matt Dobson) and American Forest & Paper Association (Brad Douglas), requests Approval as Modified by this Public Comment.

Modify proposal as follows:

**TABLE R703.4
WEATHER-RESISTANT SIDING ATTACHMENT AND MINIMUM THICKNESS**

SIDING MATERIAL	NOMINAL THICKNESS ^a (inches)	JOINT TREATMENT	WATER-RESISTIVE BARRIER REQUIRED	TYPE OF SUPPORTS FOR THE SIDING MATERIAL AND FASTENERS ^{b,c,d}						
				Wood or wood structural panel sheathing	Fiberboard sheathing into stud	Gypsum sheathing into stud	Foam plastic sheathing into stud	Direct to studs	Number of spacing of fasteners	
Vinyl siding ^m	0.035	Lap	Yes	0.120 nail (shank) with a .313 head or 16 gauge staple with 3/8 to 1/2-in crown ^{bb,cc}	0.120 nail (shank) with a .313 head or 16 gauge staple with 3/8 to 1/2-in crown ^{bb}	0.120 nail (shank) with a .313 head or 16 gauge staple with 3/8 to 1/2-in crown ^{bb}	0.120 nail (shank) with a .313 head or 16 gauge staple with 3/8 to 1/2-in crown ^{bb}	Refer to per Section R703.11.2 ^{bb}	Not allowed	16 inches on center or as specified by the manufacturer instructions or test report

(Portions of table and footnotes not shown remain unchanged)

R703.11.2 Design Wind Pressure. Where installed over solid sheathing or backing material capable of independently resisting the required wind loads, vinyl siding shall be installed in accordance with Table 703.4 and in accordance with the manufacturer's installation instructions for the applicable design wind suction pressure condition per Tables R301.2(2) and R301.2(3). Where foam plastic sheathing is used as a backing material, the design wind pressure ratings in the vinyl siding manufacturer's installation instructions shall be adjusted in accordance with the following wall assembly conditions:

1. For foam plastic sheathing applied directly over a solid backing material capable of resisting the wind load, the vinyl siding's design wind pressure rating shall be used without adjustment.
2. For foam plastic sheathing with gypsum wallboard or equivalent on interior side of wall, multiply the vinyl siding's design wind pressure rating by 0.39.
3. For foam plastic sheathing without gypsum wallboard or equivalent on interior side of wall or gable roof end framing, multiply the vinyl siding's design wind pressure rating by 0.27.

The adjusted design wind pressure rating for the applicable assembly shall meet or exceed the applicable design wind suction pressure of Tables R301.2(2) and R301.2(3) and shall apply to conditions where design is required in accordance with Section R703.4.

Exception: Where the vinyl siding manufacturer's installation instructions specifically provide a wind pressure rating for installation over foam sheathing, those instructions shall be used in lieu of the above adjustments.

R703.11.2 Foam Plastic Sheathing. Vinyl siding used with foam plastic sheathing shall be installed in accordance with R703.11.2.1, R703.11.2.2, or R703.11.2.3.

Exemption: Where the foam plastic sheathing is applied directly over wood structural panels, fiberboard, gypsum sheathing, or other approved backing capable of independently resisting the design wind pressure, the vinyl siding shall be installed in accordance with R703.11.1.

R703.11.2.1 Basic Wind Speed Not Exceeding 90 mph and Exposure Category B. Where the basic wind speed does not exceed 90 mph, the Exposure Category is B and gypsum wall board or equivalent is installed on the side of the wall opposite the foam plastic sheathing, the minimum siding fastener penetration into wood framing shall be 1-1/4 inches (32 mm) using minimum 0.120-inch diameter nail (shank) with a minimum 0.313-inch diameter head, 16 inches on center. The foam plastic sheathing shall be minimum 1/2-inch-thick (nominal) extruded polystyrene per ASTM C578, 1/2-inch-thick (nominal) polyisocyanurate per ASTM C1289, or 1-inch-thick (nominal) expanded polystyrene per ASTM C578.

R703.11.2.2 Basic Wind Speed Exceeding 90mph or Exposure Categories C and D. Where the basic wind speed exceeds 90 mph or the Exposure Category is C or D, or all conditions of R703.11.2.1 are not met, the adjusted design pressure rating for the assembly shall meet or exceed the loads listed in Tables R301.2(2) adjusted for height and exposure using R301.2(3). The design wind pressure rating of the vinyl siding for installation over solid sheathing as provided in the vinyl siding manufacturer's product specifications shall be adjusted for the following wall assembly conditions:

1. For wall assemblies with foam plastic sheathing on the exterior side and gypsum wall board or equivalent on the interior side of the wall, the vinyl siding's design wind pressure rating shall be multiplied by 0.39.
2. For wall assemblies with foam plastic sheathing on the exterior side and no gypsum wall board or equivalent on the interior side of wall, the vinyl siding's design wind pressure rating shall be multiplied by 0.27.

R703.11.2.3 Manufacturer Specification. Where the vinyl siding manufacturer's product specifications provide an approved design wind pressure rating for installation over foam plastic sheathing, use of this design wind pressure rating shall be permitted and the siding shall be installed in accordance with the manufacturer's installation instructions.

Commenter's Reason: This public comment was initially submitted as an amendment at the code development hearing in February. The reason for disapproval was primarily related to the extensive nature of the modification. At the request of the Code Development Committee, this improved modification has received significant input and support. It also is technically consistent with the original RB195 proposal and improves the usability and clarity of the proposal. These new requirements will improve the wind-resistant performance of combinations of foam sheathing and vinyl siding commonly used to meet or exceed energy code requirements and newer green building guidelines or standards. First, a simple prescriptive approach and limitations are proposed in Section R703.11.2.1 for the 90 mph, Exposure B condition. These prescriptive requirements are consistent with the more broadly applicable adjustment factor approach of Section R703.11.2.2. The prescriptive requirements and adjustment factors are based on certified testing of various combinations of foam sheathing and vinyl siding products conducted at the NAHB Research Center, Inc. and also testing serving as the basis for the wind pressure rating method for vinyl siding as explained in ASTM D3679,

Annex A. Second, the proposal clarifies that a 1-1/4" siding nail penetration is required in lieu of the current 3/4" penetration that applies only when vinyl siding is installed over a solid substrate which is independently capable of resisting wind suction pressure. In addition, this proposal increases the safety factor from 1.5 to 2.0 for wind pressure resistance of foam sheathing and vinyl siding assemblies. This proposal is needed to ensure adequate wind pressure performance of foam sheathing and vinyl siding assemblies.

Final Action: AS AM AMPC___ D

RB200-07/08 R703.8

Proposed Change as Submitted:

Proponent: Gerald Anderson, City of Overland Park, KS, representing himself

Revise as follows:

R703.8 Flashing. All penetrations and/or openings in exterior walls shall be protected (flushed) Approved corrosion-resistant shall be applied shingle fashion in such a manner that will to prevent the entry of water into the wall cavity or penetration of water to the building structural framing components. The Flashing components shall be applied in a shingle fashion and direct water extend to the surface of the exterior wall finish or to the weather-resistive barrier for subsequent drainage. Material and components used to flash penetrations and other openings shall be water resistant and corrosion resistant. Approved corrosion-resistant Flashing shall be installed at all of The following locations shall be flashed:

1. Exterior window and door openings. ~~Flashing at exterior window and door openings shall extend to the surface to the exterior wall finish or to the water resistive barrier for subsequent drainage.~~
2. Under window and door sills.
3. At penetrations of ducts, electrical boxes or pipes.
- 2 4. At the intersection of chimneys or other masonry construction with frame or stucco walls, with projecting lips on both sides under stucco copings.
- 3 5. Under and at the ends of masonry, wood or metal copings and sills.
- 4 6. Continuously above all projecting wood trim.
- 5 7. Where exterior porches, decks or stairs attach to a wall or floor assembly of wood-frame construction.
8. At wall and roof intersections.
9. At built – in gutters.

Reason: The majority of the language in Section R703.8 has been in the code for some time. I believe that the original intent of this section was to primarily address the use of metal flashing which was the primary means of flashing openings and other penetrations at one time. Protecting openings and other penetrations from water infiltration is very important. Sealing these penetrations and openings encompasses the use of more materials than just the metal flashing (drip caps). What I have attempted to do is broaden the language to address the need to protect all penetrations in a manner which would prevent water infiltration.

This section is a general requirement which speaks to the need to flash openings in exterior walls. More detail requirements concerning flashing are found else where in the code.

Another reason for needing new language is for clarity sake. In the 04/05 code cycle a code change inserted new language which allowed flashings to extend to the weather resistive barrier. This new language has caused a lot of confusion as to what it means. When this section only appears to address the use of metal flashing, then this additional language makes no sense, but if "flashing" speaks to more than the use of the metal flashing, the additional language becomes more meaningful.

Cost Impact: The code change proposal will not increase the cost of construction.

Committee Action:

Disapproved

Committee Reason: There are some issues with conjunctions. The proponent of RB200-07/08 and RB201-07/08 should work to combine and bring this back.

Assembly Action:

None

Individual Consideration Agenda

This item is on the agenda for individual consideration because a public comment was submitted.

Public Comment:

Gerald Anderson, City of Overland Park, KS, representing himself, requests Approval as Modified by this Public Comment.

Modify proposal as follows:

Add new definition as follows:

**SECTION R202
GENERAL DEFINITIONS**

PAN FLASHING. Corrosion-resistant flashing component located at the base of an exterior opening.

Revise as follows:

R613.1 General. This section prescribes performance and construction requirements for exterior window and door systems installed in wall systems. Windows and doors shall be installed ~~and flashed~~ in accordance with the fenestration manufacturer's written installation instructions. Window and door openings shall be flashed in accordance with Section R703.8. Written installation instructions shall be provided by the fenestration manufacturer for each window or door.

R703.8 Flashing. All penetrations and/or openings in exterior walls shall be ~~protected~~ (flashed) in a manner ~~which that~~ will prevent entry of water into the wall cavity or penetration of water to the building structural framing components. Flashing components shall be applied in a shingle fashion and direct water to the surface of the exterior wall finish or to the weather-resistive barrier for subsequent drainage. Material and components used to flash penetrations and other openings shall be water resistant and corrosion resistant. The following locations shall be flashed:

1. Exterior window and door openings. Fenestrations shall be flashed in accordance with the manufacturer's instructions or shall be flashed in accordance with a design of a registered design professional. In addition, pan flashing shall be installed at the sill of exterior window and door openings. Pan flashing shall be sloped, or sealed, with a back dam and side dams. The pan flashing shall be incorporated with the flashing components used to protect the head and sides of the opening.
- ~~2. Under window and door sills.~~
- ~~3.2.~~ At penetrations of ducts, electrical boxes or pipes.
- ~~4.3.~~ At the intersection of chimneys or other masonry construction with frame or stucco walls, with projecting lips on both sides under stucco copings.
- ~~5.4.~~ Under and at the ends of masonry, wood or metal copings and sills.
- ~~6.5.~~ Continuously above all projecting wood trim.
- ~~7.6.~~ Where exterior porches, decks or stairs attach to a wall or floor assembly of wood-frame construction.
- ~~8.7.~~ At wall and roof intersections.
- ~~9.8.~~ At built – in gutters.

Commenter's Reason: This section is a general requirement which speaks to the need to flash openings in exterior walls. More detail requirements concerning flashing can be found else where in the code.

The majority of the language in section 703.8 has been in the code for some time. I believe that the original intent of this section was to primarily address the use of metal flashing which was the primary means of flashing openings and other penetrations at one time. Protecting openings and other penetrations from water infiltration is very important. Sealing these penetrations and openings encompasses the use of more materials than just the metal flashing (drip caps). What I have attempted to do is broaden the language to address the need to protect all penetrations in a manner which would prevent water infiltration.

In addition, I have also included some of the proposed language from RB201. The committee heard RB200 and RB201 together. The committee asked the proponents to try and get together to work out a solution. Section 613.1 was part of RB201. I am proposing to strike the word "flashing" as previously proposed in RB201. It is unnecessary to address flashing in R613.1 since the very next sentence refers the user to flash openings in accordance with R703.8. In addition, I have also added an exception to R703.8 to allow for a registered design professional to submit flashing details which was also previously proposed in RB201. Finally, I clarified the need for pan flashing which was more or less part of RB200 and RB201.

Another reason for needing new language is for clarity sake. In the 04/05 code cycle a code change inserted new language which allowed flashings to extend to the weather resistive barrier. This new language has caused a lot of confusion as to what it means. When this section only appears to address the use metal flashing then this additional language makes no sense but if "flashing" speaks to more than the use of the metal flashing the additional language becomes more meaningful.

Final Action: AS AM AMPC____ D

RB201-07/08

R202 (New), R613.1, R703.8, R703.8.1 (New), R703.8.2 (New), R703.8.3 (New), R703.8.4 (New), R703.8.5 (New), R703.8.6 (New), R703.8.7 (New)

Proposed Change as Submitted:

Proponent: John Woestman, The Kellen Company, representing the Window and Door Manufacturers Association

1. Add new definition as follows:

**SECTION R202
GENERAL DEFINITIONS**

PAN FLASHING. A type of corrosion-resistant flashing that is integrated into the building envelope at the base of a window or door rough opening that diverts incidental water to the exterior surface of a weather resistive barrier.

2. Revise as follows:

R613.1 (Supp) General. This section prescribes performance and construction requirements for exterior window and door systems installed in wall systems. Windows and doors shall be installed ~~and flashed~~ in accordance with the fenestration manufacturer's written installation instructions. Window and door openings shall be flashed in accordance with Section R703.8. Written installation instructions shall be provided by the fenestration manufacturer for each window or door.

R703.8 Flashing. Approved corrosion-resistant flashing shall be applied shingle-fashion in such a manner to prevent entry of water into the wall cavity or penetration of water to the building structural framing components. The flashing shall extend to the surface of the exterior wall finish. Approved corrosion-resistant flashings shall be installed ~~at all of the following locations~~ in accordance with Sections R703.8.1 through R703.8.7.

1- **R703.8.1** Exterior window and door openings. Flashing at exterior window and door openings shall extend to the surface of the exterior wall finish or to the water-resistive barrier for subsequent drainage in accordance with one of the following methods:

1. In accordance with the fenestration manufacturer's installation and flashing instructions.
2. Pan flashing. Pan flashing shall be installed at the sill of exterior window and door openings and shall be sloped, or sealed with a back dam and side dams, in such a manner to drain water to the exterior surface of a weather-resistive barrier to prevent re-entry of water into the wall cavity or onto interior finishes, and shall maintain the thermal envelope of the building.
3. In accordance with the flashing design of a registered design professional.
4. For installations outside the scope of the window or door manufacturer's instructions, flashing shall be in accordance with the flashing manufacturer's instructions.

2- **R703.8.2** At the intersection of chimneys or other masonry construction with frame or stucco walls, with projecting lips on both sides under stucco copings.

3- **R703.8.3** Under and at the ends of masonry, wood or metal copings and sills.

4- **R703.8.4** Continuously above all projecting wood trim.

5- **R703.8.5** Where exterior porches, decks or stairs attach to a wall or floor assembly of wood-frame construction.

6- **R703.8.6** At wall and roof intersections.

7- **R703.8.7** At built-in gutters.

Reason: proposal identifies alternate flashing methods for windows and doors that complement the requirements of Section R703.8 but allow appropriate window and door flashing options depending on the specific conditions of the project.

The modification of Section R613.1 helps differentiate that section R703.8 contains flashing requirements while Section R613.1, focuses on the structural aspects of the installation of exterior windows and doors.

Window and door manufactures are required, by Section R613.1, to provide installation instructions for each window and door. Many window and door manufacturers are now incorporating some method of pan flashing in their window and door installation instructions. Explicitly allowing flashing design by a registered design professional reminds the code user of this option. Window and door manufacturers create installation and flashing instructions for a wide variety of wall conditions but are unable to create installation instructions for every conceivable wall condition. The fourth flashing method identified in this proposal allows necessary flexibility while retaining the performance requirements of Section R703.8.

This proposal also introduces a definition of pan flashing into the code.

Cost Impact: The code change proposal will not increase the cost of construction.

Committee Action:

Disapproved

Committee Reason: The proponent should work with the proponent of RB200-07/08 and rework and bring this back. The modification offered was too extensive and did not allow enough time for the committee to study.

Assembly Action:

None

Individual Consideration Agenda

This item is on the agenda for individual consideration because public comments were submitted.

Public Comment 1:

John Woestman, The Kellen Company, representing the Window and Door Manufacturers Association (WDMA), requests Approval as Modified by this Public Comment.

Modify proposal as follows:

**SECTION R202
GENERAL DEFINITIONS**

PAN FLASHING. ~~A type of Corrosion-resistant flashing at the base of an opening that is integrated into the building envelope at the base of a window or door rough opening that diverts incidental water to the exterior surface of a weather resistive barrier.~~

R703.8 Flashing. ~~Approved corrosion resistant flashing shall be applied shingle fashion in such a manner to Penetrations and openings in exterior walls shall be flashed in such a manner that will prevent entry of water into the wall cavity or penetration of water to the building structural framing components. The flashing shall extend~~ Flashing components shall be applied shingle fashion and shall direct water to the surface of the exterior wall finish. ~~Approved corrosion resistant flashings shall be installed in accordance with Sections R703.8.1 through R703.8.7. Material and components used to flash penetrations and openings shall be water resistant and corrosion resistant. The following locations shall be flashed:~~

R703.8.4 1. Exterior window and door openings. Flashing at exterior window and door openings shall extend to the surface of the exterior wall finish or to the water-resistive barrier for subsequent drainage. Flashing at exterior window and door openings shall be installed in accordance with one or more of the following methods:

- ~~1. In accordance with the fenestration manufacturer's installation and flashing instructions.~~
- ~~2. Pan flashing. Pan flashing shall be installed at the sill of exterior window and door openings and shall be sloped, or sealed with a back dam and side dams, in such a manner to drain water to the exterior surface of a weather resistive barrier to prevent re-entry of water into the wall cavity or onto interior finishes, and shall maintain the thermal envelope of the building.~~
- ~~3. In accordance with the flashing design of a registered design professional.~~
- ~~4. For installations outside the scope of the window or door manufacturer's instructions, flashing shall be in accordance with the flashing manufacturer's instructions.~~

1.1 Fenestration manufacturers instructions. The fenestration manufacturer's installation and flashing instructions, or for applications not addressed in the fenestration manufacturer's instructions, in accordance with the flashing manufacturer's instructions.

1.2 Registered design professional. In accordance with the flashing design or method of a registered design professional.

Where flashing instructions or details are not provided per 1.1 or 1.2, pan flashing shall be installed at the sill of exterior window and door openings. Pan flashing shall be sloped, or sealed with a back dam and side dams. Openings using pan flashing shall incorporate flashing or protection at the head and sides.

R703.8.2 2. At the intersection of chimneys or other masonry construction with frame or stucco walls, with projecting lips on both sides under stucco copings.

R703.8.3 3. Under and at the ends of masonry, wood or metal copings and sills.

R703.8.4 4. Continuously above all projecting wood trim.

R703.8.5 5. Where exterior porches, decks or stairs attach to a wall or floor assembly of wood-frame construction.

R703.8.6 6. At wall and roof intersections.

R703.8.7 7. At built-in gutters.

(Portions of proposal not shown remain unchanged)

Commenter's Reason: WDMA recommends Approval as Modified by this Public Comment.

WDMA has incorporated feedback and requests from builders and code officials to be more explicit but also allow mandatory options for flashing windows and doors. WDMA has also collaborated with the proponent of RB200.

WDMA members strongly desire that their window and door products be installed per their installation and flashing instructions but also realize that not every application for their products can be feasibly addressed in their extensive installation instructions. Builders have requested the necessary flexibility to use alternate, but mandatory, flashing methods for windows and doors.

Public Comment 2:

John Woestman, The Kellen Company, representing the Window and Door Manufacturers Association (WDMA), requests Approval as Modified by this Public Comment.

Modify proposal as follows:

**SECTION R202
GENERAL DEFINITIONS**

PAN FLASHING. ~~A type of Corrosion-resistant flashing at the base of an opening that is integrated into the building envelope at the base of a window or door rough opening that diverts incidental water to the exterior surface of a weather resistive barrier.~~

R703.8 Flashing. ~~Approved corrosion-resistant flashing shall be applied shingle fashion in such a manner to Penetrations and openings in exterior walls shall be flashed in such a manner that will prevent entry of water into the wall cavity or penetration of water to the building structural framing components. The flashing shall extend~~ Flashing components shall be applied shingle fashion and shall direct water to the surface of the exterior wall finish. ~~Approved corrosion-resistant flashings shall be installed in accordance with Sections R703.8.1 through R703.8.7. Material and components used to flash penetrations and openings shall be water resistant and corrosion resistant. The following locations shall be flashed:~~

R703.8.1 1. Exterior window and door openings. Flashing at exterior window and door openings shall extend to the surface of the exterior wall finish or to the water-resistive barrier for subsequent drainage. Flashing at exterior window and door openings shall be installed in accordance with one or more of the following ~~methods~~:

- ~~1. In accordance with the fenestration manufacturer's installation and flashing instructions.~~
- ~~2. Pan flashing. Pan flashing shall be installed at the sill of exterior window and door openings and shall be sloped, or sealed with a back dam and side dams, in such a manner to drain water to the exterior surface of a weather resistive barrier to prevent re-entry of water into the wall cavity or onto interior finishes, and shall maintain the thermal envelope of the building.~~
- ~~3. In accordance with the flashing design of a registered design professional.~~
- ~~4. For installations outside the scope of the window or door manufacturer's instructions, flashing shall be in accordance with the flashing manufacturer's instructions.~~

1.1 Fenestration manufacturers instructions. The fenestration manufacturer's installation and flashing instructions, or for applications not addressed in the fenestration manufacturer's instructions, in accordance with the flashing manufacturer's instructions.

1.2 Registered design professional. In accordance with the flashing design or method of a registered design professional.

Where flashing instructions or details are not provided per 1.1 or 1.2, pan flashing shall be installed at the sill of exterior window and door openings. Pan flashing shall be sloped, or sealed with a back dam and side dams. Openings using pan flashing shall incorporate flashing or protection at the head and sides.

2. At penetrations of ducts, electrical boxes or pipes.

R703.8.2 3. At the intersection of chimneys or other masonry construction with frame or stucco walls, with projecting lips on both sides under stucco copings.

R703.8.3 4. Under and at the ends of masonry, wood or metal copings and sills.

R703.8.4 5. Continuously above all projecting wood trim.

R703.8.5 6. Where exterior porches, decks or stairs attach to a wall or floor assembly of wood-frame construction.

R703.8.6 7. At wall and roof intersections.

R703.8.7 8. At built-in gutters.

(Portions of proposal not shown remain unchanged)

Commenter's Reason: WDMA recommends Approval as Modified by this Public Comment.

WDMA has incorporated feedback and requests from builders and code officials to be more explicit but also allow mandatory options for flashing windows and doors. WDMA has also collaborated with the proponent of RB200 to include in this public comment the requirement for flashing ducts, electrical boxes or pipes.

WDMA members strongly desire that their window and door products be installed per their installation and flashing instructions but also realize that not every application for their products can be feasibly addressed in their extensive installation instructions. Builders have requested the necessary flexibility to use alternate, but mandatory, flashing methods for windows and doors.

Final Action: AS AM AMPC____ D

RB204 -07/08

R202 (New), R703.12 (New), R703.12.1 (New), R703.12.2 (New), R703.12.3 (New), Chapter 43 (New)

Proposed Change as Submitted:

Proponent: Marcelo M. Hirschler, GBH International, representing the American Fire Safety Council

Add new text as follows:

SECTION R202 GENERAL DEFINITIONS

POLYPROPYLENE SIDING. A shaped material, made principally from polypropylene homopolymer, or copolymer, which in some cases may contain fillers and/or reinforcements, that is used to clad exterior walls of buildings.

R703.12 Polypropylene siding. Polypropylene siding shall be certified and labeled as conforming to the requirements of ASTM D 7254 by an approved quality control agency and as meeting the requirements of R703.12.1 or of R703.12.2.

R703.12.1 Flame spread index. The polypropylene siding material shall exhibit a flame spread index of no more than 200 when tested in accordance with ASTM E 84 or UL 723 with a test specimen that is either self-supporting by its own structural characteristics or held in place by added supports along the test specimen surface and does not generate flaming drips.

R703.12.2 Heat release. The polypropylene siding material shall exhibit a peak rate of heat release not exceeding 400 kW/m² when tested in accordance with ASTM E 1354 at an incident heat flux of 50 kW/m², in the horizontal orientation and at the thickness intended for use.

R703.12.3 Installation. Polypropylene siding shall be installed in accordance with the manufacturer's installation instructions.

Add standards to Chapter 43 as follows:

ASTM

<u>D 7254-07</u>	<u>Standard Specification for Polypropylene (PP) Siding</u>
<u>E 1354-04a</u>	<u>Standard Test Method for Heat and Visible Smoke Release Rates for Materials and Products Using an Oxygen Consumption Calorimeter</u>

Reason: Polypropylene siding is being used in residential construction although the IRC does not permit it. Therefore, it is important to regulate the use of polypropylene siding in a way that it can be used safely. The new sections are similar to the existing sections on vinyl siding, except for the fire testing. Vinyl siding is known to have adequate fire performance since the siding needs to be made of rigid (unplasticized) PVC in accordance with ASTM D 3679. Polypropylene is known not to have adequate fire performance unless properly fire retarded.

A new standard specification has been issued for polypropylene siding, ASTM D 7254. The specification addresses many of the key requirements for the material. Unfortunately the fire test requirement in ASTM D 7254 is not explicit enough. ASTM D 7254 does not require that, when fire testing is conducted in the ASTM E 84 (Steiner tunnel), the test specimen must remain in place during the test and flaming drips are not allowed to happen. This requirement is critical for materials that are used exposed so that the flame spread index assesses actual surface flame spread on the material surface. The standards committee responsible for the ASTM E 84 fire test (ASTM E05) decided that this issue should be addressed in the code rather than in the standard itself. Polypropylene that has not been appropriately fire retarded will release abundant amount of heat, much more than other combustible sidings permitted by the code, such as wood siding or vinyl (PVC) siding, and spread fire through flaming drips. Such flaming drips will contribute to ignite mulch and debris found near the building and spread the fire.

When tested in the cone calorimeter, ASTM E 1354, under the same conditions, it was found that non fire retarded polypropylene exhibits a peak heat release rate of 1509 kW/m², while a non fire retarded PVC material exhibits a peak heat release rate of 183 kW/m², and a Douglas fir material exhibits a peak heat release rate of 221 kW/m². Such a very high heat release rate is unacceptable for a siding material. Testing in the cone calorimeter, including the testing above, is normally conducted in the horizontal orientation with radiant heat exposing the test specimen from above, thus capturing any flaming drips and assessing their effects.

Recent fire tests were also conducted in the Steiner tunnel, ASTM E 84, on a rigid PVC material 0.06 in. thick; it exhibited a flame spread index of 10. Under the same test conditions, a fire retarded polypropylene material 0.15 in. thick exhibited a flame spread index of 50. These are both very adequate values, in view of the fact that both the polypropylene material and the PVC material remained in place during the ASTM E 84 test and did not generate flaming drips.

This shows that it is possible to use fire retarded polypropylene materials that give very adequate flame spread values and also very adequate heat release values, without flaming drips. Consequently, polypropylene siding should only be used when it is shown to exhibit the appropriate fire performance.

ASTM E 1354, the cone calorimeter, is a test that is already referenced in the ICC family of codes in both the IFC and the IBC, in both cases with the same pass-fail criteria used here. In the IFC the test is being used for plastic materials in large wastebaskets (section 808.1) and in the IBC it is used for plastic materials in children's playgrounds (section 402.11.1).

Cost Impact: The proposal should not increase the cost of construction.

Analysis: Review of proposed new standards ASTM D 7254-07 and E 1354-04a indicated that, in the opinion of ICC Staff, the standard did comply with ICC standards criteria.

Committee Action:

Disapproved

Committee Reason: Based on the committee's previous action on RB203-07/08. Proponent needs to work with industry and bring this back.

Assembly Action:

None

Individual Consideration Agenda

This item is on the agenda for individual consideration because a public comment was submitted.

Public Comment:

Marcelo M. Hirschler, GBH International, representing the American Fire Safety Council, requests Approval as Modified by this Public Comment.

Replace proposal with the following:

**SECTION R202
GENERAL DEFINITIONS**

POLYPROPYLENE SIDING. A shaped material, made principally from polypropylene homopolymer, or copolymer, which in some cases may contain fillers and/or reinforcements, that is used to clad exterior walls of buildings.

R703.12 Polypropylene siding. Polypropylene siding shall be certified and labeled as conforming to the requirements of ASTM D 7254 by an approved quality control agency and as meeting the requirements of R703.12.1 or of R703.12.2.

R703.12.1 Flame spread index. The polypropylene siding material shall exhibit a flame spread index of no more than 200 when tested in accordance with ASTM E 84 or UL 723 with a test specimen that is either self-supporting by its own structural characteristics or held in place by added supports along the test specimen surface and does not generate flaming drips.

R703.12.2 Heat release. The polypropylene siding material shall exhibit a peak rate of heat release not exceeding 400 kW/m² when tested in accordance with ASTM E 1354 at an incident heat flux of 50 kW/m², in the horizontal orientation and at the thickness intended for use.

R703.12.3 Installation. Polypropylene siding shall be installed in accordance with the manufacturer's installation instructions.

Add standards to Chapter 43 as follows:

ASTM

D 7254-07 Standard Specification for Polypropylene (PP) Siding

E 1354-04a Standard Test Method for Heat and Visible Smoke Release Rates for Materials and Products Using an Oxygen Consumption Calorimeter

Part 1: Definitions: Add a new definition to Chapter 2 as follows:

POLYPROPYLENE SIDING. A shaped material, made principally from polypropylene homopolymer, or copolymer, which in some cases may contain fillers and/or reinforcements, that is used to clad exterior walls of buildings.

Part 2: Add a new section R703.12 as follows:

R703.12 Polypropylene siding. Polypropylene siding shall be certified and labeled as conforming to the physical requirements of ASTM D 7254 by an approved quality control agency and as meeting the fire safety requirements of R703.12.1 or of R703.12.2.

R703.12.1 Flame spread index. The polypropylene siding material shall exhibit a flame spread index of no more than 200 when tested in accordance with ASTM E 84 or UL 723 with a test specimen that is either self-supporting by its own structural characteristics or held in place by added supports along the test specimen surface. The listing shall indicate that the material does not generate flaming drips during the test.

R703.12.2 Heat release. A 4 foot by 8 foot section of polypropylene siding material shall exhibit a maximum heat release rate not exceeding 100 kW when tested in accordance with UL 1975.

R703.12.3 Installation. Polypropylene siding shall be installed in accordance with the manufacturer's installation instructions.

Add standards to Chapter 43 as follows:

ASTM

D7254-07 Standard Specification for Polypropylene (PP) Siding

UL 1975-96 Fire Test of Foamed Plastics Used for Decorative Purposes

Commenter's Reason: There are several reasons for the need for this proposal. Polypropylene siding is a material that will burn very vigorously when exposed to a very small ignition source. In fact, polypropylene is one of the plastics materials (together with polyethylene) that exhibit the highest level of heat release of all plastics. When polypropylene burns it releases about 7 times as much heat as wood and much more heat than foam plastics. Therefore, polypropylene siding should not be allowed to simply replace wood siding without added fire safety requirements. ASTM D 7254 alone does not have adequate fire safety requirements for polypropylene siding.

There was discussion that using a small scale test, such as ASTM E 1354, was inappropriate, and therefore a larger scale test (UL 1975) is being recommended here; that is the same test used in the IBC and the IFC for foam plastic materials in kiosks and in exhibit booths and in plastic signs. The pass/fail criterion of 150 kW is used for foam plastic signs in malls. When polypropylene siding that has not been properly fire retarded and/or reinforced with cellulose or wood or fibers is tested in the Steiner tunnel test (ASTM E 84) a puddle is quickly formed on the floor from the molten polypropylene material and no valid test result with ceiling flame spread is obtained.

It is important to note also that polypropylene siding and vinyl siding look very much alike, even though vinyl siding has excellent fire performance. Vinyl siding is made of rigid PVC and is required to meet only a small mild fire test (ASTM D 635 or UL 94 HB) in its specification. That is perfectly appropriate if it is indeed vinyl siding as the fire test is simply a quality control tool.

It is of interest that only one company, Nailite, has an evaluation report for polypropylene siding (namely NER 580, reissued in December 2005, long before ASTM D 7254, the specification for polypropylene siding, was developed). On the other hand, many companies have evaluation reports for vinyl siding and many companies sell vinyl siding, including some that do not advertise that fact. This leads to the potential for confusion in the marketplace.

Final Action: AS AM AMPC___ D

RB205-07/08

R802.7.1, R802.8, R806.1

Proposed Change as Submitted:

Proponent: Gary J. Ehrlich, PE, National Association of Home Builders

Revise as follows:

R802.7.1 Sawn lumber. Notches in solid lumber joists, rafters, blocking and beams shall not exceed one-sixth of the depth of the member, shall not be longer than one-third of the depth of the member and shall not be located in the middle one-third of the span. Notches at the ends of the member shall not exceed one-fourth the depth of the member. The tension side of members 4 inches (102 mm) or greater in nominal thickness shall not be notched except at the ends of the members. The diameter of the holes bored or cut into members shall not exceed one-third the depth of the member. Holes shall not be closer than 2 inches (51 mm) to the top or bottom of the member, or to any other hole located in the member. Where the member is also notched, the hole shall not be closer than 2 inches (51 mm) to the notch.

Exception: Notches on cantilevered portions of rafters are permitted provided the dimension of the remaining portion of the rafter is not less than 4-inch nominal (102 mm) and the length of the cantilever does not exceed 24 Inches (610 mm).

R802.8 Lateral support. Roof framing members Rafters and ceiling joists having a depth-to-thickness ratio exceeding 5 to 1 based on nominal dimensions shall be provided with lateral support at points of bearing to prevent rotation. For roof rafters with ceiling joists attached per Table R602.3(1), the depth-thickness ratio for the total assembly shall be determined using the combined thickness of the rafter plus the attached ceiling joist.

R806.1 (Supp) Ventilation required. Enclosed attics and enclosed rafter spaces formed where ceilings are applied directly to the underside of roof rafters shall have cross ventilation for each separate space by ventilating openings protected against the entrance of rain or snow. Ventilation openings shall have a least dimension of 1/16 inch (1.6 mm) minimum and 1/4 inch (6.4 mm) maximum. Ventilation openings larger than 1/4 inch (6.4 mm) shall be provided with corrosion-resistant wire cloth screening, hardware cloth, or similar material with 1/8 inch (3.2 mm) minimum and 1/4 inch (6.4 mm) maximum openings. Openings in roof framing members shall conform to the requirements of R802.7.

Reason: This change clarifies the requirements for lateral support of roof framing members and for openings in members used to provide lateral support.

Section R802.7.1 is revised to add "blocking" to the notching and drilling requirements for sawn lumber. Right now, the IRC does not clearly provide guidance for how to provide openings for venting where full-depth solid blocking is present. Builders are required to either provide engineered blocking solutions or comply with difficult-to-construct standard details. This change will provide uniform prescriptive guidance to coordinate blocking requirements with venting requirements.

Section R802.8 is revised to clarify that the lateral support requirements should be applied to all framing used in roof construction, not just dimension lumber used as rafters. Additional text derived from AF&PA's Wood Frame Construction Manual is provided to address the condition of roof rafters with parallel ceiling joists attached. This assembly has a larger resistance to rotation, so the total effective thickness should be used to determine the depth-thickness ratio.

Section R806.1 is provided with a reference to the notching and drilling requirements of R802.7 where ventilation openings are required in roof framing members (blocking, especially). This reference closes the loop by clarifying that a prescriptive option exists for dealing with openings in blocking.

Cost Impact: The code change proposal will not increase the cost of construction.

Committee Action:

Approved as Submitted

Committee Reason: Based on the proponent's published reason.

Assembly Action:

None

Individual Consideration Agenda

This item is on the agenda for individual consideration because a public comment was submitted.

Public Comment:

Larry Wainright, WTCA, representing the Structural Building Components Industry, requests Approval as Modified by this Public Comment.

Modify proposal as follows:

R802.8 Lateral support. Roof framing members and ceiling joists having a depth-to-thickness ratio exceeding 5 to 1 based on nominal dimensions shall be provided with lateral support at points of bearing to prevent rotation. For roof rafters with ceiling joists attached per Table R602.3(1), the depth-thickness ratio for the total assembly shall be determined using the combined thickness of the rafter plus the attached ceiling joist.

Exception: Roof trusses shall be braced in accordance with Section R802.10.3.

(Portions of proposal not shown remain unchanged)

Commenter's Reason: If roof trusses are included in this section, the reference to nominal dimensions does not make sense and would cause a conflict with Section R802.10.3, which addresses the need for bracing to prevent rotation and provide for stability of the truss system.

Final Action: AS AM AMPC___ D

**RB206-07/08
R802.10.5**

Proposed Change as Submitted:

Proponent: Rick Davidson, City of Maple Grove, MN, representing the Association of Minnesota Building Officials (AMBO)

Revise as follows:

R802.10.5 Truss to wall connection. Trusses shall be connected to wall plates ~~by the use of approved with connectors approved for such use, installed according to the manufacturer's installation instructions, and having a resistance to uplift of not less than 175 pounds (779 N) and shall be installed in accordance with the manufacturer's specifications the uplift specified on the truss design drawings.~~ For roof assemblies subject to wind uplift pressures of 20 pounds per square foot (960 Pa) or greater, as established in Table R301.2(2), adjusted for height and exposure per Table R301.2(3), see section R802.11.

Reason: This code change improves this section of the code by eliminating the 175 pound limitation for the connectors. While the basis for this limit was provided when this text was approved by the membership for inclusion in the 2003 IRC, some have argued that it is arbitrary. The new text is more prescriptive in nature which meets the goal of the IRC and eliminates discretion on the part of the building official as long as the connector is used as designed. The application is simple in that it only requires matching the uplift listed on the truss design drawings with the listed uplift resistance of the connector.

Cost Impact: The code change proposal will not increase the cost of construction.

Committee Action: Disapproved

Committee Reason: The uplift numbers used in the truss report may not be indicative of the entire assembly and may be too conservative.

Assembly Action: None

Individual Consideration Agenda

This item is on the agenda for individual consideration because a public comment was submitted.

Public Comment:

Rick Davidson, City of Maple Grove, MN, representing the Association of Minnesota Building Officials, requests Approval as Submitted.

Commenter's Reason: This proposal is intended to address some of the criticism of this code section that the current rule provides an arbitrary uplift requirement for the connector. The amendment requires that the connector only exceed the uplift listed for the individual truss on the truss design drawings.

Curiously, the committee disapproved this code change with the comment that "The uplift numbers used in the truss report may not be indicative of the entire assembly and may be too conservative". This flies in the face of conventional wisdom.

The truss industry has long advocated matching the uplift for each individual truss with the uplift resistance of the connector used to restrain that truss. Now all of a sudden we are to consider the entire assembly! Truss designers do not provide this information. Is the committee suggesting that additional information be provided or that truss roofs be fully designed?

The only thing that is being amended in this code change is that the connector be matched with the uplift for that truss. It is a simple and realistic solution.

Final Action: AS AM AMPC___ D

RB207-07/08

Table R602.3(1), R802.10.5, R802.11.1, Table R802.11

Proposed Change as Submitted:

Proponent: T. Eric Stafford, PE, representing the Institute for Business and Home Safety

1. Revise as follows:

TABLE R602.3(1) (Supp)
FASTENER SCHEDULE FOR STRUCTURAL MEMBERS

DESCRIPTION OF BUILDING ELEMENTS	NUMBER AND TYPE OF FASTENER ^{a,b,c}	SPACING OF FASTENERS
Rafter or roof truss to plate, toe nail	2 3-16d box nails (3 1/2"x0.135") or 3-10d common nails (3"x0.148")	2 toe nails on one side and 1 toe nail on opposite side of each rafter or truss

(Portions of table and footnotes not shown remain unchanged)

2. Delete without substitution:

~~**R802.10.5 Truss to wall connection.** Trusses shall be connected to wall plates by the use of approved connectors having a resistance to uplift of not less than 175 pounds (779 N) and shall be installed in accordance with the manufacturer's specifications. For roof assemblies subject to wind uplift pressures of 20 pounds per square foot (960 Pa) or greater, as established in Table R301.2(2), adjusted for height and exposure per Table R301.2(3), see section R802.11.~~

3. Revise as follows:

~~**R802.11.1 Uplift resistance.** Roof assemblies which are subject to wind uplift pressures of 20 pounds per square foot (960 Pa) or greater shall have roof rafters or trusses attached to their supporting wall assemblies by connections capable of providing the resistance required in Table R802.11. Wind uplift pressures shall be determined using an effective wind area of 100 square feet (9.3 m²) and Zone 1 in Table R301.2(2), as adjusted for height and exposure per Table R301.2(3). Rafters and trusses shall be attached to supporting wall assemblies by connections capable of resisting uplift forces as determined by one of the following methods:~~

1. as specified in Table R802.11; or
2. as specified on the Truss Design Drawings; or
3. as specified by a registered design professional.

Where the uplift force does not exceed 200 pounds, rafters and trusses are permitted to be attached to their supporting wall assemblies in accordance with Table R602.3(1).

A continuous load path shall be designed to transmit the uplift forces from the rafter or truss ties to the foundation.

4. Delete existing Table R802.11 and substitute as follows:

TABLE R802.11
RAFTER OR TRUSS UPLIFT CONNECTION FORCES FROM WIND
(POUNDS PER CONNECTION)

Rafter or Truss Spacing	Roof Span (feet)	Basic Wind Speed (mph)			
		85	90	100	110
12" O.C.	12	47	62	93	127
	24	70	93	145	202
	36	93	126	198	277
	48	116	159	251	353
16" O.C.	12	63	83	124	169
	24	93	124	193	269
	36	124	168	264	369
	48	155	212	335	471
24" O.C.	12	94	124	186	254
	24	140	186	290	404
	36	186	252	396	554
	48	232	318	502	706

For SI: 1 inch = 25.4 mm, 1 foot = 304.8 mm, 1 mph = 0.447 m/s, 1 pound = 0.454 kg.

- a. The uplift connection forces are based on a 30 foot mean roof height located in Exposure B. For Exposures C and D and for other mean roof heights, multiply the above forces by the Adjustment Coefficients in Table R301.2(3).
- b. The uplift connection forces include an allowance for roof and ceiling assembly dead load of 15 psf.
- c. The tabulated uplift connection forces are limited to a maximum roof overhang of 24 inches.
- d. The tabulated uplift connection forces are permitted to be multiplied by 0.75 for connections not located within 8 feet of building corners.
- e. For wall-to-wall and wall-to-foundation connections, the uplift connection force is permitted to be reduced by 60 plf for each full wall above.
- f. Linear interpolation between tabulated roof spans and wind speeds is permitted.

Reason:

Item 1-This change reflects current installation practice for most of the country. Increasing the number of fasteners from 2 to 3 allows for prescriptive rafter/truss fastening to resist typical roof uplift forces in proposed Table R802.11.

Item 2-The deletion of R802.10.5 allows for uniform evaluation of roof framing to wall connections regardless of framing type. This is in line with other design standards such as the *2001 Wood Frame Construction Manual* and the *SSTD10-99*. Parts 3 and 4 propose modifications to R802.11 that address the intent of R802.10.5.

Item 3-The current 20 psf pressure that triggers uplift consideration is only one factor that is needed to determine the uplift reaction at the end of the rafter/truss. The roof span, overhang, and rafter/truss spacing all affect the uplift reaction at the ends of rafters and trusses. These additional factors are included in the proposed Table R802.11, which makes this table a more appropriate reference for this code section.

The first exception allows for trusses which have been designed per R802.10.1 or specified by a registered design professional to use forces that have been determined for a specific residential structure instead of the prescriptive loads in Table R802.11.

The second exception relies upon the prescriptive fastening proposed in Part 1 to transfer uplift to the wall. The 200 pounds trigger represents a reasonable value that was derived from consideration of the NDS values for toenails, the fact that one of the nails will be driven from the opposite side and the results of both laboratory and field testing of toenailed connections with fasteners installed in opposing directions.

The word "ties" was removed from the last sentence because the point of origin of the wind uplift force is the roof assembly, not the "tie". Additionally, R802.11.1 requires a "connection" which may or may not be a "tie". This revised wording allows the use of alternate toenail quantities or nail types when the 200 pound limit is exceeded.

Item 4-Table R802.11 has been replaced with forces derived from the *2001 Wood Frame Construction Manual* Table 2.2A. Footnotes have been written to address current footnotes to Table R802.11 as well as footnotes found in *2001 WFCM* Table 3.4.

Cost Impact: The code change proposal will increase the cost of construction.

Committee Action:

Disapproved

Committee Reason: This is a good proposal and is headed in the right direction. It is not ready at this time given that there were two modifications ruled out of order. More data is needed. This should be reworked and brought back.

Assembly Action:

None

Individual Consideration Agenda

This item is on the agenda for individual consideration because public comments were submitted.

Public Comment 1:

Gary J. Ehrlich, P.E., National Association of Home Builders (NAHB), requests Approval as Modified by this Public Comment.

Modify proposal as follows:

**TABLE R602.3(1) (Supp)
FASTENER SCHEDULE FOR STRUCTURAL MEMBERS**

DESCRIPTION OF BUILDING ELEMENTS	NUMBER AND TYPE OF FASTENER ^{a,b,c}	SPACING OF FASTENERS
Rafter or roof truss to plate, toe nail	3-16d box nails (3 1/2"x0.135") or 3-10d common nails (3"x0.148")	2 toe nails on one side and 1 toe nail on opposite side of each rafter or truss ¹

a through l (No change)

- i. Where a rafter is fastened to an adjacent parallel ceiling joist in accordance with this schedule, provide two toe-nails on one side of the rafter and toe-nails from the ceiling joist to top plate in accordance with this schedule. The toe-nail on the opposite side of the rafter shall not be required.

(Portions of table and footnotes not shown remain unchanged)

R802.11.1 Uplift resistance. Rafters and trusses shall be attached to supporting wall assemblies by connections capable of resisting uplift forces as determined by one of the following methods:

1. as specified in Table R802.11; **or**
2. as specified on the Truss Design Drawings; **or**
3. as specified by a registered design professional.

Where the uplift force does not exceed 200 pounds, rafters and trusses ~~are~~ shall be permitted to be attached to their supporting wall assemblies in accordance with Table R602.3(1).

Where the basic wind speed does not exceed 90mph, the wind exposure category is B, the roof pitch is 5:12 or greater, and the roof span is 32 feet or less, rafters and trusses shall be permitted to be attached to their supporting wall assemblies in accordance with Table R602.3(1).

A continuous load path shall be designed to transmit the uplift forces from the rafter or truss ties to the foundation.

Replace the proposed Table R802.11 with the following:

**Table R802.11
Rafter or Truss Uplift Connection Forces from Wind
(Pounds per connection)**

Rafter or Truss Spacing	Roof Span (feet)	EXPOSURE B							
		Basic Wind Speed (MPH)							
		85		90		100		110	
		Roof Pitch		Roof Pitch		Roof Pitch		Roof Pitch	
		<5:12	≥5:12	<5:12	≥5:12	<5:12	≥5:12	<5:12	≥5:12
12" o.c.	12	47	41	62	54	93	81	127	110
	18	59	51	78	68	119	104	165	144
	24	70	61	93	81	145	126	202	176
	28	77	67	104	90	163	142	227	197
	32	85	74	115	100	180	157	252	219
	36	93	81	126	110	198	172	277	241
	42	105	91	143	124	225	196	315	274
	48	116	101	159	138	251	218	353	307
16" o.c.	12	63	55	83	72	124	108	169	147
	18	78	68	103	90	159	138	219	191
	24	93	81	124	108	193	168	269	234
	28	102	89	138	120	217	189	302	263
	32	113	98	153	133	239	208	335	291
	36	124	108	168	146	264	230	369	321
	42	139	121	190	165	299	260	420	365
	48	155	135	212	184	335	291	471	410
24" o.c.	12	94	82	124	108	186	162	254	221
	18	117	102	155	135	238	207	329	286
	24	140	122	186	162	290	252	404	351
	28	154	134	208	181	326	284	454	395
	32	170	148	230	200	360	313	504	438
	36	186	162	252	219	396	345	554	482
	42	209	182	285	248	449	391	630	548
	48	232	202	318	277	502	437	706	614
Rafter or Truss Spacing	Roof Span (feet)	EXPOSURE C							
		Basic Wind Speed (MPH)							
		85		90		100		110	
		Roof Pitch		Roof Pitch		Roof Pitch		Roof Pitch	
		<5:12	≥5:12	<5:12	≥5:12	<5:12	≥5:12	<5:12	≥5:12
12" o.c.	12	94	82	114	99	157	137	206	179
	18	120	104	146	127	204	177	268	233
	24	146	127	179	156	251	218	330	287
	28	164	143	201	175	283	246	372	324
	32	182	158	224	195	314	273	414	360
	36	200	174	246	214	346	301	456	397
	42	227	197	279	243	394	343	520	452

	<u>48</u>	<u>254</u>	<u>221</u>	<u>313</u>	<u>272</u>	<u>441</u>	<u>384</u>	<u>583</u>	<u>507</u>
16" o.c.	<u>12</u>	<u>125</u>	<u>109</u>	<u>152</u>	<u>132</u>	<u>209</u>	<u>182</u>	<u>274</u>	<u>238</u>
	<u>18</u>	<u>160</u>	<u>139</u>	<u>194</u>	<u>169</u>	<u>271</u>	<u>236</u>	<u>356</u>	<u>310</u>
	<u>24</u>	<u>194</u>	<u>169</u>	<u>238</u>	<u>207</u>	<u>334</u>	<u>291</u>	<u>439</u>	<u>382</u>
	<u>28</u>	<u>218</u>	<u>190</u>	<u>267</u>	<u>232</u>	<u>376</u>	<u>327</u>	<u>495</u>	<u>431</u>
	<u>32</u>	<u>242</u>	<u>211</u>	<u>298</u>	<u>259</u>	<u>418</u>	<u>364</u>	<u>551</u>	<u>479</u>
	<u>36</u>	<u>266</u>	<u>231</u>	<u>327</u>	<u>284</u>	<u>460</u>	<u>400</u>	<u>606</u>	<u>527</u>
	<u>42</u>	<u>302</u>	<u>263</u>	<u>372</u>	<u>324</u>	<u>524</u>	<u>456</u>	<u>691</u>	<u>601</u>
	<u>48</u>	<u>338</u>	<u>294</u>	<u>416</u>	<u>362</u>	<u>587</u>	<u>511</u>	<u>775</u>	<u>674</u>
24" o.c.	<u>12</u>	<u>188</u>	<u>164</u>	<u>228</u>	<u>198</u>	<u>314</u>	<u>273</u>	<u>412</u>	<u>358</u>
	<u>18</u>	<u>240</u>	<u>209</u>	<u>292</u>	<u>254</u>	<u>408</u>	<u>355</u>	<u>536</u>	<u>466</u>
	<u>24</u>	<u>292</u>	<u>254</u>	<u>358</u>	<u>311</u>	<u>502</u>	<u>437</u>	<u>660</u>	<u>574</u>
	<u>28</u>	<u>328</u>	<u>285</u>	<u>402</u>	<u>350</u>	<u>566</u>	<u>492</u>	<u>744</u>	<u>647</u>
	<u>32</u>	<u>364</u>	<u>317</u>	<u>448</u>	<u>390</u>	<u>628</u>	<u>546</u>	<u>828</u>	<u>720</u>
	<u>36</u>	<u>400</u>	<u>348</u>	<u>492</u>	<u>428</u>	<u>692</u>	<u>602</u>	<u>912</u>	<u>793</u>
	<u>42</u>	<u>454</u>	<u>395</u>	<u>558</u>	<u>485</u>	<u>786</u>	<u>684</u>	<u>1040</u>	<u>905</u>
	<u>48</u>	<u>508</u>	<u>442</u>	<u>626</u>	<u>545</u>	<u>882</u>	<u>767</u>	<u>1166</u>	<u>1014</u>

For SI: 1 inch = 25.4 mm, 1 foot = 304.8 mm, 1 mph = 0.447 m/s, 1 pound = 0.454 kg.

- The uplift connection forces are based on a maximum 33.30 foot mean roof height ~~located in~~ and Wind Exposure Category B or C. For Exposure D, the uplift connection force shall be selected from the Exposure C portion of the table using the next highest tabulated basic wind speed. The Adjustment Coefficients in Table R301.2(3) shall not be used to multiply the above forces for Exposures C and D ~~and or~~ for other mean roof heights, ~~multiply the above forces by the Adjustment Coefficients in Table R301.2(3).~~
- The uplift connection forces include an allowance for roof and ceiling assembly dead load of 15 psf.
- The tabulated uplift connection forces are limited to a maximum roof overhang of 24 inches.
- The tabulated uplift connection forces ~~are~~ shall be permitted to be multiplied by ~~0.75~~ 0.65 for connections not located within 8 feet of building corners.
- For wall-to-wall and wall-to-foundation connections, the uplift connection force is ~~is~~ shall be permitted to be reduced by 60 plf for each full wall above.
- Linear interpolation between tabulated roof spans and wind speeds is shall be permitted.
- The tabulated forces for a 12" on center spacing shall be permitted to be used to determine the uplift load in pounds per linear foot.

Commenter's Reason: Both the current Table R802.11 and the proposed Table R802.11 based on WFCM values are overly conservative for many typical houses. The uplift loads are based on low-slope (4:12 pitch or less) roofs. The table does not account for the reduction in uplift loads that occur on higher-slope (5:12 pitch or greater) roofs or on hip roofs per ASCE 7. Thus the code does not encourage the use of high-slope roofs, which have been shown to experience significantly less damage in high-wind events. In fact, the latest NAHB Builder Practices Survey indicates that the average roof slope is 8:12, and that the predominate roof pitches are in the range of 7:12 to 10:12. Further, the addition of the 200 pound maximum capacity for a 3-16d slant-nail connection proposed by IBHS will subject many houses in low-wind areas to a requirement for roof-to-wall ties (not to mention continuous straps to the foundation) that is not justified by the actual performance of roof systems in low-wind areas. This requirement is particularly unjustified on higher-slope roofs where the uplift loads can be substantially reduced through a detailed analysis using ASCE 7.

This public comment introduces two factors for high-slope roofs; one to adjust the table values for edge zone loading on roofs with 5:12 slope or greater, and one to adjust the table values for interior zone loading on roofs with 5:12 slope or greater. These factors were derived using the ASCE 7 wind provisions and the calculation method used to develop Table 2.2A of the WFCM, from which the proposed values in RB207 are taken. A factor for hip roofs is also added, as hip roofs have seen similar improved performance in high-wind events. By providing these factors, use of high-slope roofs will be encouraged, as designers, engineers and builders will be able to appropriately reduce uplift loads and avoid triggering uplift connector requirements for building locations and for roof configurations where the requirements are not justified. NAHB asks for your support in approving this proposal as modified by this public comment.

Public Comment 2:

Gary J. Ehrlich, P.E., National Association of Home Builders (NAHB), requests Approval as Modified by this Public Comment.

Modify proposal as follows:

R802.11.1 Uplift resistance. Rafters and trusses shall be attached to supporting wall assemblies by connections capable of resisting uplift forces as determined by one of the following methods:

- as specified in Table R802.11; or
- as specified on the Truss Design Drawings; or
- as specified by a registered design professional.

Where the uplift force does not exceed 200 pounds, rafters and trusses are permitted to be attached to their supporting wall assemblies in accordance with Table R602.3(1).

~~A continuous load path shall be designed to transmit the uplift forces from the rafters or trusses to the foundation.~~

**Table R802.11
Rafter or Truss Uplift Connection Forces from Wind
(Pounds per connection)**

(Portions of table not shown remain unchanged)

- a. The uplift connection forces are based on a 30 foot mean roof height located in Exposure B. For Exposures C and D and for other mean roof heights, multiply the above forces by the Adjustment Coefficients in Table R301.2(3).
- b. The uplift connection forces include an allowance for roof and ceiling assembly dead load of 15 psf.
- c. The tabulated uplift connection forces are limited to a maximum roof overhang of 24 inches.
- d. The tabulated uplift connection forces are permitted to be multiplied by 0.75 for connections not located within 8 feet of building corners.
- e. ~~For wall to wall and wall to foundation connections, the uplift connection force is permitted to be reduced by 60 plf for each full wall above.~~
- f. ~~e.~~ Linear interpolation between tabulated roof spans and wind speeds is permitted.

Commenter's Reason: This public comment removes the continuous load path requirement from Section R802.11 and the related footnote in Table R802.11 providing a dead load reduction. This language often leads to the truss designer and supplier being required to design the continuous load path, creating a liability issue for the structural building components industry. A public comment to RB148 adds the two requirements being deleted here to the Section R602.10 wall bracing provisions, and links back to this section and table. This proposed change completes the move of those requirements to Chapter 6, where they are more appropriately accessed by code officials, builders, and engineers, and removes the liability issue for the truss manufacturers. NAHB asks for your support of this public comment.

Final Action: AS AM AMPC____ D

RB209-07/08 R804, Chapter 43 (New)

Proposed Change as Submitted:

Proponent: Bonnie Manley, American Iron and Steel Institute

1. Revise as follows:

R804.1.1 Applicability limits. The provisions of this section shall control the construction of steel roof framing for buildings not greater than 60 feet (18 288 mm) perpendicular to the joist, rafter or truss span, not greater than 40 feet (12 192 mm) in width parallel to the joist span or truss, ~~not greater than two~~ less than or equal to three stories in height and roof slopes not smaller than 3:12 (25-percent slope) or greater than 12:12 (100 percent slope). Cold-formed steel roof framing constructed in accordance with the provisions of this section shall be limited to sites subjected to a maximum design wind speed of 110 miles per hour (49 m/s), Exposure A, B, or C, and a maximum ground snow load of 70 pounds per square foot (3350 Pa).

R804.1.2 In-line framing. Cold-formed steel roof framing constructed in accordance with Section R804 shall be located ~~directly~~ in line with load-bearing studs in accordance with the tolerances specified in Section R804.1.2(a) or R804.1.2(b) and with Figure R804.1.2.

1. ~~with a~~ The maximum tolerance shall be of 3/4 inch (19.1 mm) between the centerline of the horizontal framing member and the centerline of the vertical framing member between the center line of the stud and the roof joist/rafter.
2. Where the centerline of the horizontal framing member and bearing stiffener are located to one side of the center line of the vertical framing member, the maximum tolerance shall be 1/8 inch (3 mm) between the web of the horizontal framing member and the edge of the vertical framing member.

2. Delete without substitution:

~~**R804.1.3 Roof trusses.** The design, quality assurance, installation and testing of cold-formed steel trusses shall be in accordance with AISI Standard for Cold-formed Steel Framing Truss Design (COFS/Truss). Truss members shall not be notched, cut or altered in any manner without an approved design.~~

3. Revise as follows:

R804.2 Structural framing. Load-bearing steel roof framing members shall comply with Figure R804.2(1) and with the dimensional and minimum thickness requirements specified in Tables R804.2(1) and R804.2(2). Tracks shall comply with Figure R804.2(2) and shall have a minimum flange width of 1 1/4 inches (32 mm). The maximum inside bend radius for ~~load-bearing~~ members shall be the greater of 3/32 inch (2.4 mm) or twice the uncoated base steel thickness. ~~Holes in roof framing members shall comply with all of the following conditions:~~

- ~~1. Holes shall conform to Figure R804.2(3);~~
- ~~2. Holes shall be permitted only along the centerline of the web of the framing member;~~
- ~~3. Holes shall have a center-to-center spacing of not less than 24 inches (610 mm);~~
- ~~4. Holes shall have a width not greater than 0.5 times the member depth, or 2 1/2 inches (64 mm);~~
- ~~5. Holes shall have a length not exceeding 4 1/2 inches (114 mm); and~~
- ~~6. Holes shall have a minimum distance between the edge of the bearing surface and the edge of the hole of not less than 10 inches (254 mm).~~

~~Framing members with web holes not conforming to these requirements shall be patched in accordance with Section R804.3.6 or designed in accordance with accepted engineering practices.~~

R804.2.1 Material. Load-bearing cold-formed steel framing members shall be cold-formed to shape from structural quality sheet steel complying with the requirements of one of the following:

1. ASTM A 653: Grades 33, ~~37, 40~~ and 50 (Class 1 and 3).
2. ASTM A 792: Grades 33, ~~37, 40~~ and 50A.
3. ~~ASTM A 875: Grades 33, 37, 40 and 50 (Class 1 and 3).~~
4. ASTM A 1003: Structural Grades 33 Type H, ~~37, 40~~ and 50 Type H.

R804.2.2 Identification. Load-bearing cold-formed steel framing members shall have a legible label, stencil, stamp or embossment with the following information as a minimum:

1. Manufacturer's identification.
2. Minimum ~~uncoated~~ base steel thickness in inches (mm).
3. Minimum coating designation.
4. Minimum yield strength, in kips per square inch (ksi) (kPa).

R804.2.3 Corrosion protection. Load-bearing cold-formed steel framing shall have a metallic coating complying with ASTM A 1003 and one of the following:

1. A minimum of G 60 in accordance with ASTM A 653.
2. A minimum of AZ 50 in accordance with ASTM A 792.
- ~~3. A minimum of GF 60 in accordance with ASTM A 875.~~

R804.2.4 Fastening requirements. Screws for steel-to-steel connections shall be installed with a minimum edge distance and center-to-center spacing of 1/2 inch (13 mm), shall be self-drilling tapping, and shall conform to ASTM C1513 ~~SAE J78~~. Structural sheathing shall be attached to cold-formed steel roof rafters with minimum No. 8 self-drilling tapping screws that conform to ASTM C1513 ~~SAE J78~~. Screws for attaching structural sheathing to cold-formed steel roof framing shall have a minimum head diameter of 0.292 inch (7.4 mm) with countersunk heads and shall be installed with a minimum edge distance of 3/8 inch (10 mm). Gypsum board ceilings shall be attached to cold-formed steel joists with minimum No. 6 screws conforming to ASTM C 954 or ASTM C1513 with a bugle head style and shall be installed in accordance with Section R805. For all connections, screws shall extend through the steel a minimum of three exposed threads. All ~~self-drilling tapping screws conforming to SAE J78~~ fasteners shall have rust inhibitive coating suitable for the installation in which they are being used, or be manufactured from material not susceptible to corrosion, a minimum Type II coating in accordance with ASTM B 633.

Where No. 8 screws are specified in a steel-to-steel connection, ~~reduction of~~ the required number of screws in the connection is permitted to be reduced in accordance with the reduction factors in Table R804.2.4 when larger screws are used or when one of the sheets of steel being connected is thicker than 33 mils (0.84 mm). When applying the reduction factor, the resulting number of screws shall be rounded up.

4. Add new text as follows:

R804.2.5 Web holes, web hole reinforcing, and web hole patching. Web holes, web hole reinforcing, and web hole patching shall be in accordance with this section.

R804.2.5.1 Web holes. Web holes in roof framing members shall comply with all of the following conditions:

1. Holes shall conform to Figure R804.2.5.1;
2. Holes shall be permitted only along the centerline of the web of the framing member;
3. Holes shall have a center-to-center spacing of not less than 24 inches (610 mm);
4. Holes shall have a web hole width not greater than 0.5 times the member depth, or 2 1/2 inches (64.5 mm);
5. Holes shall have a web hole length not exceeding 4 1/2 inches (114 mm); and

6. Holes shall have a minimum distance between the edge of the bearing surface and the edge of the web hole of not less than 10 inches (254 mm).

Framing members with web holes not conforming to the above requirements shall be reinforced in accordance with Section R804.2.5.2, patched in accordance with Section R804.2.5.3, or designed in accordance with accepted engineering practices.

R804.2.5.2 Web hole reinforcing. Web holes in ceiling joists not conforming to the requirements of Section R804.2.5.1 shall be permitted to be reinforced if the hole is located fully within the center 40 percent of the span and the depth and length of the hole does not exceed 65% of the flat width of the web. The reinforcing shall be a steel plate or C-shape section with a hole that does not exceed the web hole size limitations of Section R804.2.5.1 for the member being reinforced. The steel reinforcing shall be the same thickness as the receiving member and shall extend at least 1 inch (25.4 mm) beyond all edges of the hole. The steel reinforcing shall be fastened to the web of the receiving member with No.8 screws spaced no greater than 1 inch (25.4 mm) center-to-center along the edges of the patch with minimum edge distance of 1/2 inch (12.7 mm).

R804.2.5.3 Hole patching. Web holes in roof framing members not conforming to the requirements in Section R804.2.5.1 shall be permitted to be patched in accordance with either of the following methods:

1. Framing members shall be replaced or designed in accordance with accepted engineering practices where web holes exceed the following size limits:
 - 1.1. The depth of the hole, measured across the web, exceeds 70 percent of the flat width of the web; or
 - 1.2. The length of the hole measured along the web, exceeds 10 inches (254 mm) or the depth of the web, whichever is greater.
2. Web holes not exceeding the dimensional requirements in Section R804.2.5.3, Item 1, shall be patched with a solid steel plate, stud section, or track section in accordance with Figure R804.2.5.3. The steel patch shall, as a minimum, be of the same thickness as the receiving member and shall extend at least 1 inch (25 mm) beyond all edges of the hole. The steel patch shall be fastened to the web of the receiving member with No.8 screws spaced no greater than 1 inch (25 mm) center-to-center along the edges of the patch with minimum edge distance of 1/2 inch (13 mm).

5. Revise as follows:

R804.3 Roof construction. Cold-formed steel roof systems constructed in accordance with the provisions of this section shall consist of both ceiling joists and rafters in accordance with Figure R804.3 and fastened in accordance with Table R804.3, and hip framing in accordance with Section R804.3.3.

R804.3.1 Ceiling joists. Cold-formed steel ceiling joists shall be in accordance with this section.

R804.3.1.1 Allowable ceiling joist spans - Minimum ceiling joist size. The clear span of cold formed steel ceiling joists shall not exceed the limits set forth in Ceiling joist size and thickness shall be determined in accordance with the limits set forth in Tables R804.3.1.1(1) through R804.3.1.1(8). When determining the size of ceiling joists, the lateral support of the top flange shall be classified as unbraced, braced at mid-span, or braced at third points in accordance with Section R804.3.1.4. Where sheathing material is attached to the top flange of ceiling joists or where the bracing is spaced closer than third point of the joists, the "third point" values from Tables R804.3.1.1(1) through R804.3.1.1(8) shall be used.

Ceiling joists shall have a minimum bearing support length of not less than 1.5 inches (38 mm) and shall be connected to roof rafters (heel joint) with No. 10 screws in accordance with Figures R804.3.1.1(1) and R804.3.1.1(2) and Table R804.3.1.1(9).

When continuous joists are framed across interior bearing supports, the interior bearing supports shall be located within 24 inches (610 mm) of midspan of the ceiling joist, and the individual spans shall not exceed the applicable spans in Tables R804.3.1.1(2), R804.3.1.1(4), R804.3.1.1(6), R804.3.1.1(8).

Where required in Tables R804.3.1.1(1) through R804.3.1.1(8), bearing stiffeners shall be installed at each bearing location in accordance with Section R804.3.8 and Figure R804.3.8.

When the attic is to be used as an occupied space, the ceiling joists shall be designed in accordance with Section R505.

6. Add new text as follows:

R804.3.1.2 Ceiling joist bearing stiffeners. Where required in Tables R804.3.1.1(1) through R804.3.1.1(8), bearing stiffeners shall be installed at each bearing support in accordance with Figure R804.3.1.1(2). Bearing stiffeners shall be fabricated from a C-shaped or track member in accordance with the one of following:

1. C-shaped bearing stiffeners shall be a minimum 33 mil (0.84 mm) thickness.
2. Track bearing stiffener shall be a minimum 43 mil (1.09 mm) thickness.

The minimum length of a bearing stiffener shall be the depth of member being stiffened minus 3/8 inch (9.5 mm). Each stiffener shall be fastened to the web of the ceiling joist with a minimum of four No. 8 screws equally spaced as shown in Figure R804.3.1.1(2). Stiffeners shall be permitted to be installed on either side of the web.

7. Delete without substitution:

~~**R804.3.2 Ceiling joist bracing.** The bottom flanges of steel ceiling joists shall be laterally braced in accordance with Section R702. The top flanges of steel ceiling joists shall be laterally braced with a minimum of 33 mil (0.84 mm) C-section, 33 mil (0.84 mm) track section or 1 1/2 inch by 33 mil (38mm by 0.84 mm) continuous steel strapping as required in Tables R804.3.1(1) through R804.3.1(8). Lateral bracing shall be installed in accordance with Figure R804.3. C-section, tracks or straps shall be fastened to the top flange at each joist with at least one No. 8 screw and shall be fastened to blocking with at least two No. 8 screws. Blocking or bridging (X-bracing) shall be installed between joists in line with strap bracing at a maximum spacing of 12 feet (3658 mm) measured perpendicular to the joists, and at the termination of all straps. The third point bracing span values from Tables R804.3.1(1) through R804.3.1(8) shall be used for straps installed at closer spacings than third point bracing, or when sheathing is applied to the top of the ceiling joists.~~

8. Add new text as follows:

R804.3.1.3 Ceiling joist bottom flange bracing. The bottom flanges of ceiling joists shall be laterally braced by the application of gypsum board or continuous steel straps installed perpendicular to the joist run, in accordance with one of the following:

1. Gypsum board shall be fastened with No. 6 screws in accordance with Section R702.
2. Steel straps with a minimum size of 1-1/2 inch x 33 mil (38 mm x 0.84 mm) shall be installed at a maximum spacing of 4 feet (1.2 m). Straps shall be fastened to the bottom flange at each joist with one No.8 screw and shall be fastened to blocking with two No.8 screws. Blocking shall be installed between joists at a maximum spacing of 12 feet (3.7 m) measured along a line of continuous strapping (perpendicular to the joist run). Blocking shall also be located at the termination of all straps.

R804.3.1.4 Ceiling joist top flange bracing. The top flanges of ceiling joists shall be laterally braced as required by Tables R804.3.1.1(1) through R804.3.1.1(8), in accordance with one of the following:

1. Minimum 33 mil (0.84 mm) C-shaped member in accordance with Figure R804.3.1.4(1).
2. Minimum 33 mil (0.84 mm) track section in accordance with Figure R804.3.1.4(1)
3. Minimum 33 mil (0.84 mm) hat section in accordance with Figure R804.3.1.4(1)
4. Minimum 54 mil (1.37 mm) 1 1/2 inch cold-rolled channel section in accordance with Figure R804.3.1.4(1)
5. Minimum 1 1/2 inch by 33 mil (38mm by 0.84 mm) continuous steel strap in accordance with Figure R804.3.1.4(2).

Lateral bracing shall be installed perpendicular to the ceiling joists and shall be fastened to the top flange of each joist with one No. 8 screw. Blocking shall be installed between joists in line with bracing at a maximum spacing of 12 feet (3658 mm) measured perpendicular to the joists. Ends of lateral bracing shall be attached to blocking or anchored to a stable building component with two No. 8 screws.

R804.3.1.5 Ceiling joist splicing. Splices in ceiling joists shall be permitted, provided that ceiling joist splices are supported at interior bearing points and are constructed in accordance with Figure R804.3.1.5. The number of screws on each side of the splice shall be the same as required for the heel joint connection in Table R804.3.1.1(9).

9. Delete without substitution:

~~**R804.3.3 Allowable rafter spans.** The horizontal projection of the rafter span, as shown in Figure R804.3, shall not exceed the limits set forth in Table R804.3.3(1). Wind speeds shall be converted to equivalent ground snow loads in accordance with Table R804.3.3(2). Rafter spans shall be selected based on the higher of the ground snow load or the equivalent snow load converted from the wind speed. When required, a rafter support brace shall be a minimum of 350S162-33 C-section with maximum length of 8 feet (2438 mm) and shall be connected to a ceiling joist and rafter with four No. 10 screws at each end.~~

10. Add new text as follows:

R804.3.2 Roof rafters. Cold-formed steel roof rafters shall be in accordance with this section.

R804.3.2.1 Minimum roof rafter sizes. Roof rafter size and thickness shall be determined in accordance with the limits set forth in Tables R804.3.2.1(1) and R804.3.2.1(2) based upon the horizontal projection of the roof rafter span. For determination of roof rafter sizes, roof spans shall be permitted to be reduced when a roof rafter support brace is installed in accordance with Section R804.3.2.2. The reduced roof rafter span shall be taken as the larger of the distance from the roof rafter support brace to the ridge or to the heel measured horizontally.

For the purpose of determining roof rafter sizes in Tables R804.3.2.1(1) and R804.3.2.1(2), wind speeds shall be converted to equivalent ground snow loads in accordance with Table R804.3.2.1(3). Roof rafter sizes shall be based on the higher of the ground snow load or the equivalent snow load converted from the wind speed.

R804.3.2.1.1 Eave overhang. Eave overhangs shall not exceed 24 inches (610 mm) measured horizontally.

R804.3.2.1.2 Rake overhangs. Rake overhangs shall not exceed 12 inches (305 mm) measured horizontally. Outlookers at gable endwalls shall be installed in accordance with Figure R804.3.2.1.2.

R804.3.2.2 Roof rafter support brace. When used to reduce roof rafter spans in determining roof rafter sizes, a roof rafter support brace shall meet all of the following conditions:

1. Minimum 350S162-33 C-shaped brace member with maximum length of 8 feet (2.44 m).
2. Minimum brace member slope of 45 degrees to the horizontal.
3. Minimum connection of brace to a roof rafter and ceiling joist with 4 No.10 screws at each end.
4. Maximum 6 inches (152 mm) between brace/ceiling joist connection and load-bearing wall below.
5. Each roof rafter support brace greater than 4 feet (1.22 m) in length, shall be braced with a supplemental brace having a minimum size of 350S162-33 or 350T162-33 such that the maximum unsupported length of the roof rafter support brace is 4 foot (1.22 m). The supplemental brace shall be continuous and shall be connected to each roof rafter support brace using 2 No.8 screws.

R804.3.2.3 Roof rafter splice. Roof rafters shall not be spliced.

11. Revise as follows:

R804.3.2.43-4 Roof rafter to ceiling joist and ridge member connection framing. Roof rafters shall be connected to a parallel ceiling joist to form a continuous tie between exterior walls in accordance with Figures ~~R804.3 and R804.3.1.1(1) or R804.3.1.1(2)~~ and Table R804.3.1.1(9). Ceiling joists shall be connected to the top track of the load-bearing wall in accordance with Table R804.3, either with 2 No.10 screws applied through the flange of the ceiling joist or by using a 54 mil (1.37 mm) clip angle with 2 No.10 screws in each leg. Roof rafters shall be connected to a ridge member with a minimum 2-inch by 2-inch (51 mm by 51 mm) clip angle fastened with ~~minimum~~ No. 10 screws to the ridge member in accordance with Figure R804.3.2.43-4 and Table R804.3.2.43-4. The clip angle shall have a ~~minimum~~ steel thickness equivalent to or greater than as the roof rafter thickness member and shall extend the full depth of the roof rafter member to the extent possible. The ridge member shall be fabricated from a C-shaped ~~member section~~ and a track section, which shall ~~be of~~ have a minimum size and steel thickness equivalent to or greater than that of as the adjacent roof rafters and shall be installed in accordance with Figure R804.3.2.43-4. The ridge member shall extend the full depth of the sloped roof rafter cut.

12. Delete without substitution:

R804.3.3.2 Roof cantilevers. ~~Roof cantilevers shall not exceed 24 inches (610 mm) in accordance with Figure R804.3. Roof cantilevers shall be supported by a header in accordance with Section R603.6 or shall be supported by the floor framing in accordance with Section R505.3.7 R505.3.6.~~

R804.3.4 Rafter bottom flange bracing. ~~The bottom flanges of steel rafters shall be continuously braced with a minimum 33 mil (0.84 mm) C section, 33 mil (0.84 mm) track section, or a 1 1/2 inch by 33 mil (38 mm by 0.84 mm) steel strapping at a maximum spacing of 8 feet (2438 mm) as measured parallel to the rafters. Bracing shall be installed in accordance with Figure R804.3. The C section, track section, or straps shall be fastened to blocking with at least two No. 8 screws. Blocking or bridging (X bracing) shall be installed between rafters in line with the continuous bracing at a maximum spacing of 12 feet (3658 mm) measured perpendicular to the rafters and at the termination of all straps. The ends of continuous bracing shall be fastened to blocking with at least two No. 8 screws.~~

13. Add new text as follows:

R804.3.2.5 Roof rafter bottom flange bracing. The bottom flanges of roof rafters shall be continuously braced, at a maximum spacing of 8 feet (2440 mm) as measured parallel to the roof rafters, with one of the following members:

1. Minimum 33-mil (0.84 mm) C-shaped member
2. Minimum 33-mil (0.84 mm) track section-
3. Minimum 1 1/2-inch by 33-mil (38 mm by 0.84 mm) steel strap

The bracing element shall be fastened to the bottom flange of each roof rafter with one No.8 screw and shall be fastened to blocking with two No.8 screws. Blocking shall be installed between roof rafters in-line with the continuous bracing at a maximum spacing of 12 feet (3.66 m) measured perpendicular to the roof rafters. The ends of continuous bracing shall be fastened to blocking or anchored to a stable building component with two No.8 screws.

R804.3.3 Hip framing. Hip framing shall consist of jack-rafters, hip members, hip support columns and connections in accordance with this section, or shall be in accordance with an approved design. The provisions of this section for hip members and hip support columns shall only apply where the jack rafter slope is greater than or equal to the roof slope. For the purposes of determining member sizes in this section, wind speeds shall be converted to equivalent ground snow load in accordance with Table R804.3.2.1(3).

R804.3.3.1 Jack rafters. Jack rafters shall meet the requirements for roof rafters in accordance with Section R804.3.2, except that the requirements in Section R804.3.2.4 shall not apply.

R804.3.3.2 Hip members. Hip members shall be fabricated from C-shape members and track section, which shall have minimum sizes determined in accordance with Table R804.3.3.2. The C-shaped member and track section shall be connected at a maximum spacing of 24 inches using No. 10 screws through top and bottom flanges in accordance with Figure R804.3.2.4. The depth of the hip member shall match that of the roof rafters and jack rafters, or shall be based on an approved design for a beam pocket at the corner of the supporting wall.

R804.3.3.3 Hip support columns. Hip support columns shall be used to support hip members at the ridge. A hip support column shall consist of a pair of C-shape members, with a minimum size determined in accordance with Table R804.3.3.3. The C-shape members shall be connected at a maximum spacing of 24 inches on center to form a box using minimum 3-inch (76 mm) x 33-mil strap connected to each of the flanges of the C-shape members with 3-No. 10 screws. Hip support columns shall have a continuous load path to the foundation and shall be supported at the ceiling line by an interior wall or by an approved design for a supporting element.

R804.3.3.4 Hip framing connections. Hip rafter framing connections shall be installed in accordance with the following:

1. Jack rafters shall be connected at the eave to a parallel C-shape blocking member in accordance with Figure R804.3.3.4(1). The C-shape blocking member shall be attached to the supporting wall track with minimum 2-No. 10 screws.
2. Jack rafters shall be connected to a hip member with a minimum 2 inch x 2 inch (50 mm x 50 mm) clip angle fastened with No. 10 screws to the hip member in accordance with Figure R804.3.2.1.2 and Table R804.3.2.4. The clip angle shall have a steel thickness equivalent to or greater than the jack rafter thickness and shall extend the depth of the jack rafter member to the extent possible.
3. The connection of the hip support columns at the ceiling line shall be in accordance with Figure R804.3.3.4(2), with an uplift strap sized in accordance with Table R804.3.3.4(1).
4. The connection of hip support members, ridge members and hip support columns at the ridge shall be in accordance with Figures R804.3.3.4(3) and R804.3.3.4(4) and Table R804.3.3.4(2).
5. The connection of hip members to the wall corner shall be in accordance with Figure R804.3.3.4(5) and Table R804.3.3.4(3).

14. Revise as follows:

R804.3.45 Cutting and notching. Flanges and lips of load-bearing cold-formed steel roof framing members shall not be cut or notched. Holes in webs shall be in accordance with ~~Section R804.2.~~

15. Delete without substitution:

R804.3.6 Hole patching. Web holes not conforming to the requirements in Section R804.2 shall be designed in accordance with one of the following:

1. Framing members shall be replaced or designed in accordance with accepted engineering practices when web holes exceed the following size limits:
 - 1.1. The depth of the hole, measured across the web, exceeds 70 percent of the flat width of the web;
 - or;
 - 1.2. The length of the hole, measured along the web, exceeds 10 inches (254 mm) or the depth of the web, whichever is greater.
2. Web holes not exceeding the dimensional requirements in Section R804.3.6, Item 1 shall be patched with a solid steel plate, stud section, or track section in accordance with Figure R804.3.6. The steel patch shall be of a minimum thickness as the receiving member and shall extend at least 1 inch (25 mm) beyond all edges of the hole. The steel patch shall be fastened to the web of the receiving member with No. 8 screws spaced no greater than 1 inch (25 mm) center to center along the edges of the patch with minimum edge distance of 1/2 inch (13 mm).

R804.3.7 Splicing. Rafters and other structural members, except ceiling joists, shall not be spliced. Splices in ceiling joists shall only be permitted at interior bearing points and shall be constructed in accordance with Figure R804.3.7(1). Spliced ceiling joists shall be connected with the same number and size of screws on connection. Splicing of tracks shall conform to Figure R804.3.7(2).

R804.3.8 Bearing stiffener. A bearing stiffener shall be fabricated from a minimum 33 mil (0.84 mm) C-section or track section. Each stiffener shall be fastened to the web of the ceiling joist with a minimum of four No. 8 screws equally spaced as shown in Figure R804.3.8. Stiffeners shall extend across the full depth of the web and shall be installed on either side of the web.

16. Revise as follows:

R804.3.59 Headers. Roof-ceiling framing above wall openings shall be supported on headers. The allowable spans for headers in load bearing walls shall not exceed the values set forth in Section R603.6 and Tables R603.6(1) through R603.6(24).

R804.3.640 Framing of openings in roofs and ceilings. Openings in roofs and ceilings framing shall be framed with headers and trimmers joists, between ceiling joists or rafters. Header joist spans shall not exceed 4 feet (1219 mm) in length. Header and trimmer joists shall be fabricated from joist and track members having a minimum size and thickness at least equivalent to the adjacent ceiling joists or roof rafters and shall be installed sections, which shall be of a minimum size and thickness in accordance with Figures R804.3.40(1) R804.3.6(1) and R804.3.40(2) R804.3.6(2). Each header joist shall be connected to a trimmer joists with a minimum of four 2-inch by 2-inch (51 by 51 mm) clip angles. Each clip angle shall be fastened to both the header and trimmer joists with four No. 8 screws, evenly spaced, through each leg of the clip angle. The clip angles shall have a steel thickness not less than that of the ~~floor~~ ceiling joist or roof rafter. Each track section for a built-up header or trimmer joist shall extend the full length of the joist (continuous).

17. Add new text as follows:

R804.3.7 Roof trusses. Cold-formed steel trusses shall be designed and installed in accordance with AISI S100, Section D4. Trusses shall be connected to the top track of the load-bearing wall in accordance with Table R804.3, either with 2 No.10 screws applied through the flange of the truss or by using a 54 mil (1.37 mm) clip angle with 2 No.10 screws in each leg.

R804.3.8 Ceiling and roof diaphragms. Ceiling and roof diaphragms shall be in accordance with this section.

R804.3.8.1 At gable endwalls a ceiling diaphragm shall be provided by attaching a minimum 1/2-inch (13 mm) gypsum board in accordance with Tables R804.3.8(1) and R804.3.8(2) or a minimum 3/8-inch (9.5 mm) wood structural panel sheathing, which complies with Section R803, in accordance with Table R804.6(3) to the bottom of ceiling joists or roof trusses and connected to wall framing in accordance with Figures R804.3.8(1) and R804.3.8(2), unless studs are designed as full height without bracing at the ceiling. Flat blocking shall consist of C-shape or track section with a minimum thickness of 33 mils (0.84 mm).

The ceiling diaphragm shall be secured with screws spaced at a maximum 6" o.c. at panel edges and a maximum 12" o.c. in the field. The required lengths in Tables R804.3.8(1) and R804.3.8(2) for gypsum board sheathed ceiling diaphragms shall be permitted to be multiplied by 0.35 if all panel edges are blocked. The required lengths in Tables R804.3.8(1) and R804.3.8(2) for gypsum board sheathed ceiling diaphragms shall be permitted to be multiplied by 0.9 if all panel edges are secured with screws spaced at 4" o.c.

R804.3.8.2 Roof diaphragm. A roof diaphragm shall be provided by attaching a minimum of 3/8 inch (9.5 mm) wood structural panel, which complies with Section R803, to roof rafters or truss top chords in accordance with Table R804.3. Buildings with 3-1 or larger plan aspect ratio and with roof rafters slope (pitch) of 9:12 or larger shall have the roof rafters and ceiling joists blocked in accordance with Figure R804.3.8(3).

18. Revise as follows:

R804.3.9R804.4 Roof tie-down. Roof assemblies subject to wind uplift pressures of 20 pounds per square foot (0.96 kN/m²) or greater, as established in Table R301.2(2), shall have rafter-to-bearing wall ties provided in accordance with Table R802.11.

**TABLE R804.2(2)
MINIMUM THICKNESS OF COLD-FORMED STEEL MEMBERS**

DESIGNATION THICKNESS (mils)	MINIMUM BASE STEEL UNCOATED THICKNESS (inches)	REFERENCE GAGE NUMBER
33	0.03293	20
43	0.04283	48
54	0.05384	46
68	0.06778	44
97	0.0966	

For SI: 1 inch = 25.4 mm, 1 mil = 0.0254 mm.

**TABLE R804.3
ROOF FRAMING FASTENING SCHEDULE**

(No change to table entries)

- a. Screws shall be applied through the flanges of the truss or ceiling joist or a 54 mil clip angle shall be used with two No. 10 screws in each leg. See Section R804.3.84 for additional requirements to resist uplift forces.
- b. (No change)

**TABLE R804.3.1.1(1)
CEILING JOIST SPANS
SINGLE SPANS WITH BEARING STIFFENERS
10 lb per sq ft LIVE LOAD (NO ATTIC STORAGE)a, b, c 33 ksi STEEL**

(Portion of table and footnotes not shown do not change)

**TABLE R804.3.1.1(2)
CEILING JOIST SPANS
TWO EQUAL SPANS WITH BEARING STIFFENERS
10 lb per sq ft LIVE LOAD (NO ATTIC STORAGE)a, b, c 33 ksi STEEL**

(Portion of table and footnotes not shown do not change)

**TABLE R804.3.1.1(3)
CEILING JOIST SPANS
SINGLE SPANS WITH BEARING STIFFENERS
20 lb per sq ft LIVE LOAD (LIMITED ATTIC STORAGE)a, b, c 33 ksi STEEL**

(Portion of table and footnotes not shown do not change)

**TABLE R804.3.1.1(4)
CEILING JOIST SPANS
TWO EQUAL SPANS WITH BEARING STIFFENERS
20 lb per sq ft LIVE LOAD (LIMITED ATTIC STORAGE)a, b, c 33 ksi STEEL**

(Portion of table and footnotes not shown do not change)

**TABLE R804.3.1.1(5)
CEILING JOIST SPANS
SINGLE SPANS WITHOUT BEARING STIFFENERS
10 lb per sq ft LIVE LOAD (NO ATTIC STORAGE)a, b 33 ksi STEEL**

(Portion of table and footnotes not shown do not change)

**TABLE R804.3.1.1(6)
CEILING JOIST SPANS
TWO EQUAL SPANS WITHOUT BEARING STIFFENERS
10 lb per sq ft LIVE LOAD (NO ATTIC STORAGE)a, b 33 ksi STEEL**

(Portion of table and footnotes not shown do not change)

**TABLE R804.3.1.1(7)
CEILING JOIST SPANS
SINGLE SPANS WITHOUT BEARING STIFFENERS
20 lb per sq ft LIVE LOAD (LIMITED ATTIC STORAGE)a, b 33 ksi STEEL**

(Portion of table and footnotes not shown do not change)

**TABLE R804.3.1.1(8)
CEILING JOIST SPANS
TWO EQUAL SPANS WITHOUT BEARING STIFFENERS
20 lb per sq ft LIVE LOAD (LIMITED ATTIC STORAGE)a, b 33 ksi STEEL
(Portion of table and footnotes not shown do not change)**

**TABLE R804.3.1.1(9)
NUMBER OF SCREWS REQUIRED FOR CEILING JOIST TO ROOF RAFTER CONNECTION**

(Portion of table and footnotes not shown do not change)

19. Delete Table R804.3.3(1) and substitute as follows:

~~**TABLE R804.3.3(1)
ALLOWABLE HORIZONTAL RAFTER SPANS 33 ksi STEEL**~~

**TABLE R804.3.2.1(1)
ROOF RAFTER SPANS^{a,b,c}
33 ksi STEEL**

MEMBER DESIGNATION	ALLOWABLE SPAN MEASURED HORIZONTALLY (feet-Inches)							
	Ground Snow Load							
	20 psf		30 psf		50 psf		70 psf	
	Rafter Spacing (in.)							
	16	24	16	24	16	24	16	24
<u>550S162-33</u>	<u>14'-0"</u>	<u>11'-6"</u>	<u>11'-11"</u>	<u>9'-7"</u>	<u>9'-6"</u>	<u>7'-9"</u>	<u>8'-2"</u>	<u>6'-8"</u>
<u>550S162-43</u>	<u>16'-8"</u>	<u>13'-11"</u>	<u>14'-5"</u>	<u>11'-9"</u>	<u>11'-6"</u>	<u>9'-5"</u>	<u>9'-10"</u>	<u>8'-0"</u>
<u>550S162-54</u>	<u>17'-11"</u>	<u>15'-7"</u>	<u>15'-7"</u>	<u>13'-3"</u>	<u>12'-11"</u>	<u>10'-7"</u>	<u>11'-1"</u>	<u>9'-1"</u>
<u>550S162-68</u>	<u>19'-2"</u>	<u>16'-9"</u>	<u>16'-9"</u>	<u>14'-7"</u>	<u>14'-1"</u>	<u>11'-10"</u>	<u>12'-6"</u>	<u>10'-2"</u>
<u>550S162-97</u>	<u>21'-3"</u>	<u>18'-6"</u>	<u>18'-6"</u>	<u>16'-2"</u>	<u>15'-8"</u>	<u>13'-8"</u>	<u>14'-0"</u>	<u>12'-2"</u>
<u>800S162-33</u>	<u>16'-5"</u>	<u>13'-5"</u>	<u>13'-11"</u>	<u>11'-4"</u>	<u>11'-1"</u>	<u>8'-2"</u>	<u>9'-0"</u>	<u>6'-0"</u>
<u>800S162-43</u>	<u>19'-9"</u>	<u>16'-1"</u>	<u>16'-8"</u>	<u>13'-7"</u>	<u>13'-4"</u>	<u>10'-10"</u>	<u>11'-5"</u>	<u>9'-4"</u>
<u>800S162-54</u>	<u>22'-8"</u>	<u>18'-6"</u>	<u>19'-2"</u>	<u>15'-8"</u>	<u>15'-4"</u>	<u>12'-6"</u>	<u>13'-1"</u>	<u>10'-8"</u>

800S162-68	25'-10"	21'-2"	21'-11"	17'-10"	17'-6"	14'-4"	15'-0"	12'-3"
800S162-97	21'-3"	18'-6"	18'-6"	16'-2"	15'-8"	13'-8"	14'-0"	12'-2"
1000S162-43	22'-3"	18'-2"	18'-9"	15'-8"	15'-0"	12'-3"	12'-10"	10'-6"
1000S162-54	25'-8"	20'-11"	21'-8"	17'-9"	17'-4"	14'-2"	14'-10"	12'-1"
1000S162-68	29'-7"	24'-2"	25'-0"	20'-5"	20'-0"	16'-4"	17'-2"	14'-0"
1000S162-97	34'-8"	30'-4"	30'-4"	25'-10"	25'-3"	20'-8"	21'-8"	17'-8"
1200S162-54	28'-3"	23'-1"	23'-11"	19'-7"	19'-2"	15'-7"	16'-5"	13'-5"
1200S162-68	32'-10"	26'-10"	27'-9"	22'-8"	22'-2"	18'-1"	19'-0"	15'-6"
1200S162-97	40'-6"	33'-5"	34'-6"	28'-3"	27'-8"	22'-7"	23'-8"	19'-4"

For SI: 1 inch = 25.4 mm, 1 foot = 304.8 mm, 1 pound per square foot = 0.0479 kPa.

- a. Table provides maximum horizontal rafter spans in feet and inches for slopes between 3:12 and 12:12.
- b. Deflection criterion: L/240 for live loads and L/180 for total loads.
- c. Roof dead load = 12 psf.

20. Add new tables as follows:

TABLE R804.3.2.1(2)
ROOF RAFTER SPANS ^{a,b,c}
50 ksi STEEL

MEMBER DESIGNATION	ALLOWABLE SPAN MEASURED HORIZONTALLY (Feet-Inches)							
	Equivalent Ground Snow Load							
	20 psf		30 psf		50 psf		70 psf	
	Roof Rafter Spacing (in.)							
	16	24	16	24	16	24	16	24
550S162-33	15'-4"	12'-11"	13'-4"	10'-11"	10'-9"	8'-9"	9'-2"	7'-6"
550S162-43	16'-8"	14'-7"	14'-7"	12'-9"	12'-3"	10'-6"	11'-0"	9'-0"
550S162-54	17'-11"	15'-7"	15'-7"	13'-8"	13'-2"	11'-6"	11'-9"	10'-3"
550S162-68	19'-2"	16'-9"	16'-9"	14'-7"	14'-1"	12'-4"	12'-7"	11'-0"
550S162-97	21'-3"	18'-6"	18'-6"	16'-2"	15'-8"	13'-8"	14'-0"	12'-3"
800S162-33	18'-10"	15'-5"	15'-11"	12'-9"	12'-3"	8'-2"	9'-0"	6'-0"
800S162-43	22'-3"	18'-2"	18'-10"	15'-5"	15'-1"	12'-3"	12'-11"	10'-6"
800S162-54	24'-2"	21'-1"	21'-1"	18'-5"	17'-10"	14'-8"	15'-5"	12'-7"
800S162-68	25'-11"	22'-8"	22'-8"	19'-9"	19'-1"	16'-8"	17'-1"	14'-9"
800S162-97	28'-10"	25'-2"	25'-2"	22'-0"	21'-2"	18'-6"	19'-0"	16'-7"
1000S162-43	25'-2"	20'-7"	21'-4"	17'-5"	17'-0"	13'-11"	14'-7"	10'-7"
1000S162-54	29'-0"	24'-6"	25'-4"	20'-9"	20'-3"	16'-7"	17'-5"	14'-2"
1000S162-68	31'-2"	27'-3"	27'-3"	23'-9"	23'-0"	19'-6"	20'-6"	16'-8"
1000S162-97	34'-8"	30'-4"	30'-4"	26'-5"	25'-7"	22'-4"	22'-10"	20'-0"
1200S162-54	33'-2"	27'-1"	28'-1"	22'-11"	22'-5"	18'-4"	19'-3"	15'-8"
1200S162-68	36'-4"	31'-9"	31'-9"	27'-0"	26'-5"	21'-6"	22'-6"	18'-6"
1200S162-97	40'-6"	35'-4"	35'-4"	30'-11"	29'-10"	26'-1"	26'-8"	23'-1"

For SI: 1 inch = 25.4 mm, 1 foot = 304.8 mm, 1 pound per square foot = 0.0479 kPa.

- a. Table provides maximum horizontal rafter spans in feet and inches for slopes between 3:12 and 12:12.
- b. Deflection criterion: L/240 for live loads and L/180 for total loads.
- c. Roof dead load = 12 psf.

21. Revise as follows:

~~TABLE R804.3.3(2)~~**R804.3.2.1(3)**
BASIC WIND SPEED TO EQUIVALENT SNOW LOAD CONVERSION

(Portions of table shown do not change)

~~TABLE R804.3.2.43.4~~
NUMBER OF SCREWS REQUIRED AT EACH LEG OF CLIP
ANGLE FOR RAFTER TO RIDGE MEMBER CONNECTION^a

SCREWS REQUIRED AT EACH LEG OF CLIP ANGLE
FOR HIP RAFTER TO HIP MEMBER OR ROOF RAFTER TO RIDGE MEMBER CONNECTION^a

(Portions of table shown do not change)

22. Add new tables as follows:

TABLE 804.3.3.2
HIP MEMBER SIZES
33 ksi STEEL

BUILDING WIDTH (feet)	HIP MEMBER DESIGNATION^a			
	Equivalent Ground Snow Load (psf)			
	0 to 20	21 to 30	31 to 50	51 to 70
<u>24</u>	<u>800S162-68</u> <u>800T150-68</u>	<u>800S162-68</u> <u>800T150-68</u>	<u>800S162-97</u> <u>800T150-97</u>	<u>1000S162-97</u> <u>1000T150-97</u>
<u>28</u>	<u>1000S162-68</u> <u>1000T150-68</u>	<u>1000S162-68</u> <u>1000T150-68</u>	<u>1000S162-97</u> <u>1000T150-97</u>	<u>1200S162-97</u> <u>1200T150-97</u>
<u>32</u>	<u>1000S162-97</u> <u>1000T150-97</u>	<u>1000S162-97</u> <u>1000T150-97</u>	<u>1200S162-97</u> <u>1200T150-97</u>	-
<u>36</u>	<u>1200S162-97</u> <u>1200T150-97</u>	-	-	-
<u>40</u>	-	-	-	-

For SI: 1 foot = 305 mm, 1 pound per square foot = 0.0479 kPa

- a. The web depth of the roof rafters and jack rafters are to match at the hip or shall be installed in accordance with an approved design.

**TABLE 804.3.3.3
HIP SUPPORT COLUMN SIZES**

BUILDING WIDTH (feet)	HIP SUPPORT COLUMN DESIGNATION ^{a,b}			
	Equivalent Ground Snow Load (psf)			
	0 to 20	21 to 30	31 to 50	51 to 70
24	<u>2-350S162-33</u>	<u>2-350S162-33</u>	<u>2-350S162-43</u>	<u>2-350S162-54</u>
28	<u>2-350S162-54</u>	<u>2-550S162-54</u>	<u>2-550S162-68</u>	<u>2-550S162-68</u>
32	<u>2-550S162-68</u>	<u>2-550S162-68</u>	<u>2-550S162-97</u>	-
36	<u>2-550S162-97</u>	-	-	-
40	-	-	-	-

- For SI: 1 foot = 305 mm, 1 pound per square foot = 0.0479 kPa.
a. Box shape column only in accordance with Figure R804.3.3.4(2)
b. 33 ksi Steel for 33 and 43 mil material. 50 ksi Steel for thicker material.

**TABLE 804.3.3.4(1)
UPLIFT STRAP CONNECTION REQUIREMENTS
HIP SUPPORT COLUMN AT CEILING LINE**

BUILDING WIDTH (feet)	BASIC WIND SPEED (MPH)				
	85	100	110	-	-
	-	85	-	100	110
	Number of No. 10 Screws in Each End of Each 3 inch by 54-mil Steel Strap ^{a,b,c}				
24	<u>3</u>	<u>4</u>	<u>4</u>	<u>6</u>	<u>7</u>
28	<u>4</u>	<u>6</u>	<u>6</u>	<u>8</u>	<u>10</u>
32	<u>5</u>	<u>8</u>	<u>8</u>	<u>11</u>	<u>13</u>
36	<u>7</u>	<u>10</u>	<u>11</u>	<u>14</u>	<u>17</u>
40	-	-	-	-	-

- For SI: 1 foot = 305 mm, 1 pound per square foot = 0.479 kPa
a. Two straps are required, one each side of the column.
b. Space screws at ¾ inches on-center and provide ¾ inch end distance.
c. 50 ksi Steel strap.

TABLE R804.3.3.4(2)
CONNECTION REQUIREMENTS
HIP MEMBER TO HIP SUPPORT COLUMN

BUILDING WIDTH (feet)	NUMBER OF No.10 SCREWS IN EACH FRAMING ANGLE ^{A,B,C}			
	Equivalent Ground Snow Load (psf)			
	0 to 20	21 to 30	31 to 50	51 to 70
24	<u>10</u>	<u>10</u>	<u>10</u>	<u>12</u>
28	<u>10</u>	<u>10</u>	<u>14</u>	<u>18</u>
32	<u>10</u>	<u>12</u>		-
36	<u>14</u>	-	-	-
40	-	-	-	-

- For SI: 1 foot = 305 mm, 1 pound per square foot = 0.479 kPa.
- Screws to be divided equally between the connection to the hip member and the column. Refer to figures R804.3.3.4(3) and R804.3.3.4(4)
 - The number of screws required in each framing angle is not to be less than shown in Table R804.5.4(1)
 - 50 ksi Steel from the framing angle.

TABLE 804.3.3.4(3)
UPLIFT STRAP CONNECTION REQUIREMENTS
HIP MEMBER TO WALL

BUILDING WIDTH (feet)	BASIC WIND SPEED (MPH)				
	85	100	110	-	-
	-	85	-	100	110
	Number of No. 10 Screws in Each End of Each 3 inch by 54-mil Steel Strap ^{a,b,c}				
24	<u>2</u>	<u>2</u>	<u>3</u>	<u>3</u>	<u>4</u>
28	<u>2</u>	<u>3</u>	<u>3</u>	<u>4</u>	<u>5</u>
32	<u>3</u>	<u>4</u>	<u>4</u>	<u>6</u>	<u>7</u>
36	<u>3</u>	<u>5</u>	<u>5</u>	<u>7</u>	<u>8</u>
40	-	-	-	-	-

- For SI: 1 foot = 305 mm, 1 pound per square foot = 0.479 kPa
- Two straps are required, one each side of the column.
 - Space screws at 3/4 inches on-center and provide 3/4 inch end distance.
 - 50 ksi Steel strap.

TABLE R804.3.8(1)
REQUIRED LENGTHS FOR CEILING DIAPHRAGMS AT GABLE ENDWALLS
GYPSUM BOARD SHEATHED
CEILING HEIGHT = 8 ft^{a,b,c,d,e,f}

		BASIC WIND SPEED (mph)				
		85	100	110	-	-
Exposure A/B						
Exposure C		-	85	-	100	110
Roof Pitch	Building Endwall Width (ft)	Minimum Diaphragm Length (ft)				
3:12 to 6:12	24 - 28	14	20	22	28	32
	28 - 32	16	22	28	32	38
6:12	32 - 36	20	26	32	38	44
	36 - 40	22	30	36	44	50
6:12 to 9:12	24 - 28	16	22	26	32	36
	28 - 32	20	26	32	38	44
9:12	32 - 36	22	32	38	44	52
	36 - 40	26	36	44	52	60
9:12 to 12:12	24 - 28	18	26	30	36	42
	28 - 32	22	30	36	42	50
12:12	32 - 36	26	36	42	50	60
	36 - 40	30	42	50	60	70

For SI: 1 inch = 25.4 mm, 1 psf = 0.0479 kN/m², 1 mph = 1.61 km/hr, 1 foot = 305 mm

- a. Ceiling diaphragm is composed of 1/2" gypsum board (min. thickness) secured with screws spaced at 6" o.c. at panel edges and 12" o.c. in field. Use No. 8 screws (min.) when framing members have a designation thickness of 54 mils or less and No. 10 screws (min.) when framing members have a designation thickness greater than 54 mils.
- b. Maximum aspect ratio (length/width) of diaphragms is 2:1.
- c. Building width is in the direction of horizontal framing members supported by the wall studs.
- d. Required diaphragm lengths are to be provided at each end of the structure.
- e. Required diaphragm lengths are permitted to be multiplied by 0.35 if all panel edges are blocked.
- f. Required diaphragm lengths are permitted to be multiplied by 0.9 if all panel edges are secured with screws spaced at 4" o.c.

TABLE R804.3.8(2)
REQUIRED LENGTHS FOR CEILING DIAPHRAGMS AT GABLE ENDWALLS
GYP SUM BOARD SHEATHED
CEILING HEIGHT = 9 or 10 ft^{a,b,c,d,e,f}

		BASIC WIND SPEED (mph)				
Exposure A/B		85	100	110	-	-
Exposure C		-	85	-	100	110
Roof Pitch	Building Endwall Width (ft)	Minimum Diaphragm Length (ft)				
3:12 to 6:12	24 - 28	16	22	26	32	38
	28 - 32	20	26	32	38	44
	32 - 36	22	30	36	44	50
	36 - 40	26	36	42	50	58
6:12 to 9:12	24 - 28	18	26	30	36	42
	28 - 32	22	30	36	42	50
	32 - 36	26	36	42	50	58
	36 - 40	30	42	48	58	68
9:12 to 12:12	24 - 28	20	28	34	40	46
	28 - 32	24	34	40	48	56
	32 - 36	28	40	48	56	66
	36 - 40	34	46	56	66	78

For SI: 1 inch = 25.4 mm, 1 psf = 0.0479 kN/m², 1 mph = 1.61 km/hr, 1 foot = 305 mm

- Ceiling diaphragm is composed of 1/2" gypsum board (min. thickness) secured with screws spaced at 6" o.c. at panel edges and 12" o.c. in field. Use No. 8 screws (min.) when framing members have a designation thickness of 54 mils or less and No. 10 screws (min.) when framing members have a designation thickness greater than 54 mils.
- Maximum aspect ratio (length/width) of diaphragms is 2:1.
- Building width is in the direction of horizontal framing members supported by the wall studs.
- Required diaphragm lengths are to be provided at each end of the structure.
- Required diaphragm lengths are permitted to be multiplied by 0.35 if all panel edges are blocked.
- Required diaphragm lengths are permitted to be multiplied by 0.9 if all panel edges are secured with screws spaced at 4" o.c.

TABLE R804.3.8(3)
REQUIRED LENGTHS FOR CEILING DIAPHRAGMS AT GABLE ENDWALLS
WOOD STRUCTURAL PANEL SHEATHED
CEILING HEIGHT = 8, 9 OR 10 ft^{a,b,c,d,e,f}

		Basic Wind Speed (mph)				
Exposure A/B		85	100	110	-	-
Exposure C		-	85	-	100	110
Roof Pitch	Building Endwall Width (ft)	Minimum Diaphragm Length (ft)				
3:12 to 6:12	24 - 28	10	10	10	10	10
	28 - 32	12	12	12	12	12
	32 - 36	12	12	12	12	12
	36 - 40	14	14	14	14	14
6:12 to 9:12	24 - 28	10	10	10	10	10
	28 - 32	12	12	12	12	12
	32 - 36	12	12	12	12	12
	36 - 40	14	14	14	14	14
9:12 to 12:12	24 - 28	10	10	10	10	10
	28 - 32	12	12	12	12	12
	32 - 36	12	12	12	12	12
	36 - 40	14	14	14	14	14

For SI: 1 inch = 25.4 mm, 1 psf = 0.0479 kN/m², 1 mph = 1.61 km/hr, 1 foot = 305 mm

- Ceiling diaphragm is composed of 3/8" wood structural panel sheathing (min. thickness) secured with screws spaced at 6" o.c. at panel edges and in field. Use No. 8 screws (min.) when framing members have a designation thickness of 54 mils or less and No. 10 screws (min.) when framing members have a designation thickness greater than 54 mils.
- Maximum aspect ratio (length/width) of diaphragms is 3:1.

- c. Building width is in the direction of horizontal framing members supported by the wall studs.
- d. Required diaphragm lengths are to be provided at each end of the structure.

23. Add new figure as follows:

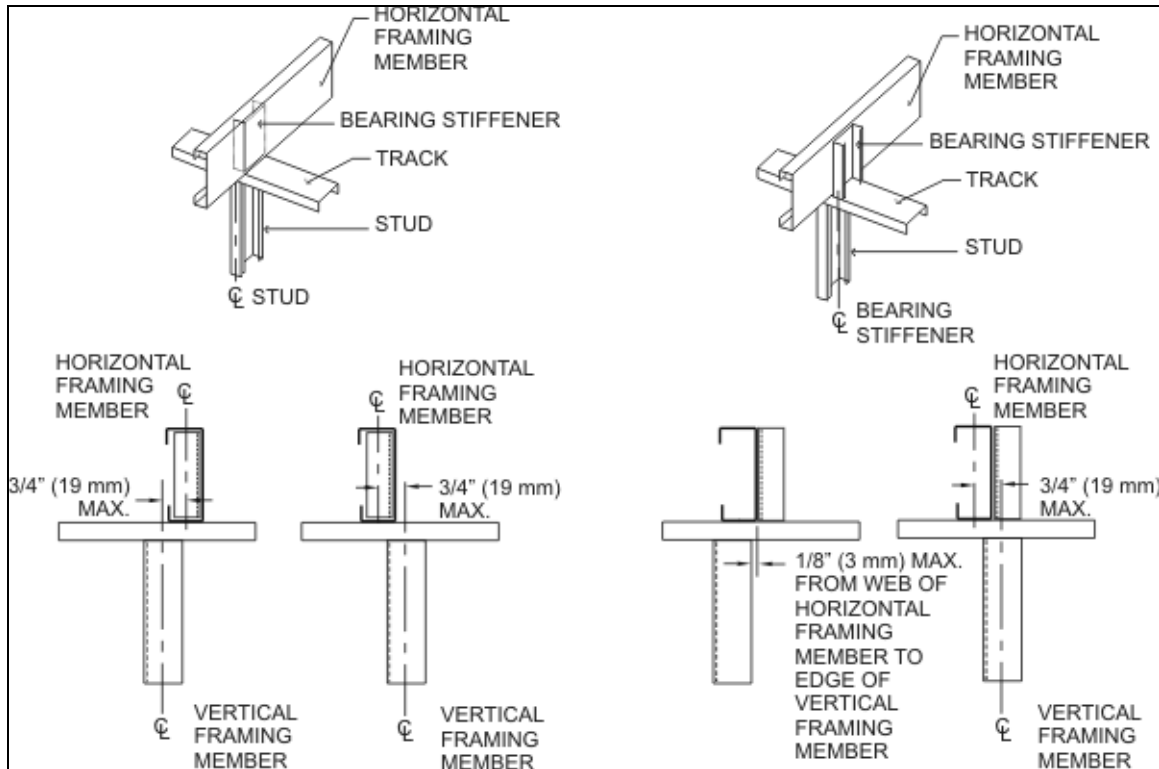

**FIGURE R804.1.2
IN-LINE FRAMING**

24. Revise as follows:

**FIGURE R804.2(1)
C-SHAPED SECTION**

(No change to figure)

**FIGURE R804.2.5.12(3)
WEB HOLES**

(No change to figure)

25. Add new figure as follows:

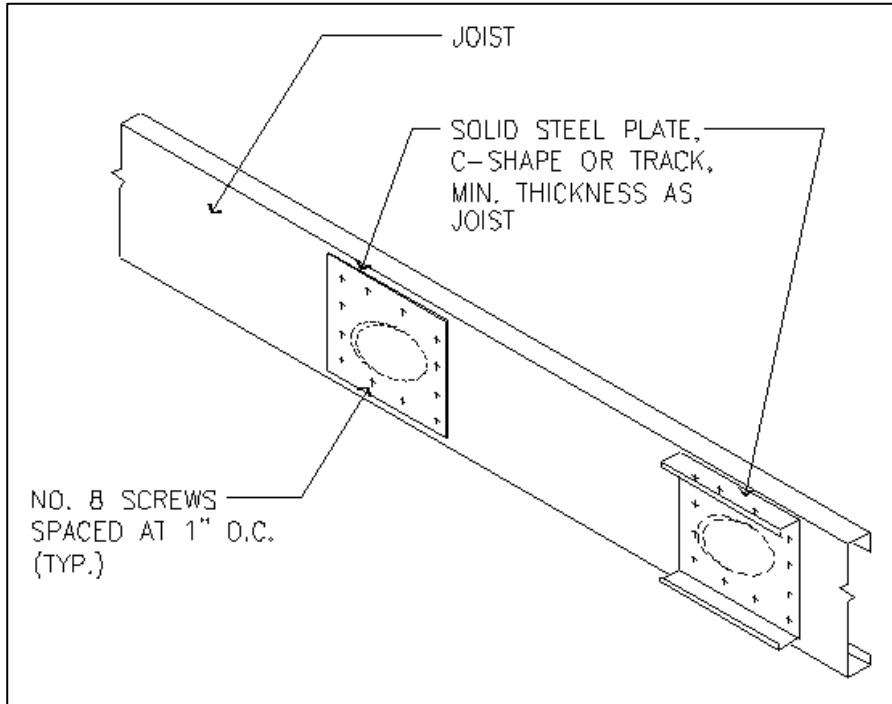
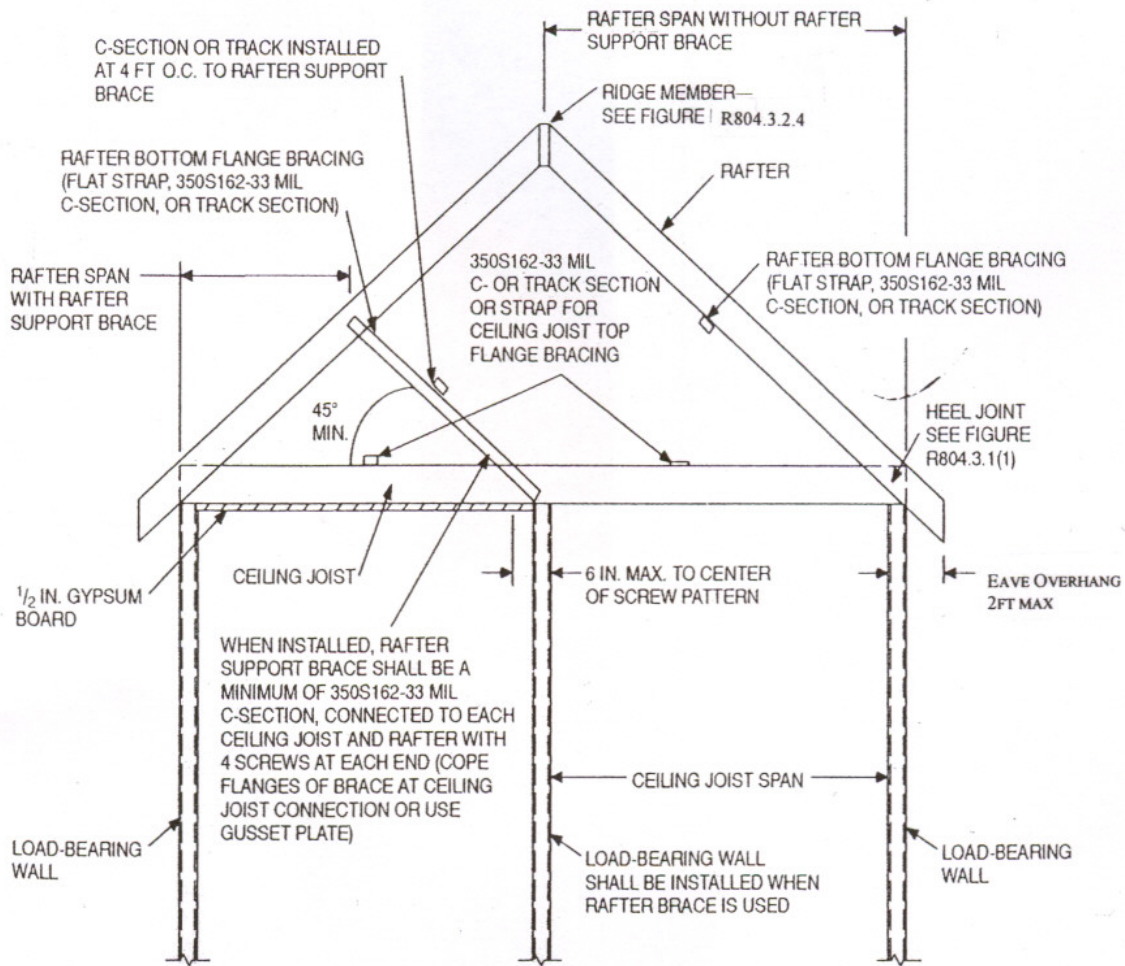

FIGURE R804.2.5.3
WEB HOLE PATCH

26. Revise as follows:



**FIGURE R804.3
STEEL ROOF CONSTRUCTION**

27. Delete existing Figure R804.3.1(1) and replace as follows:

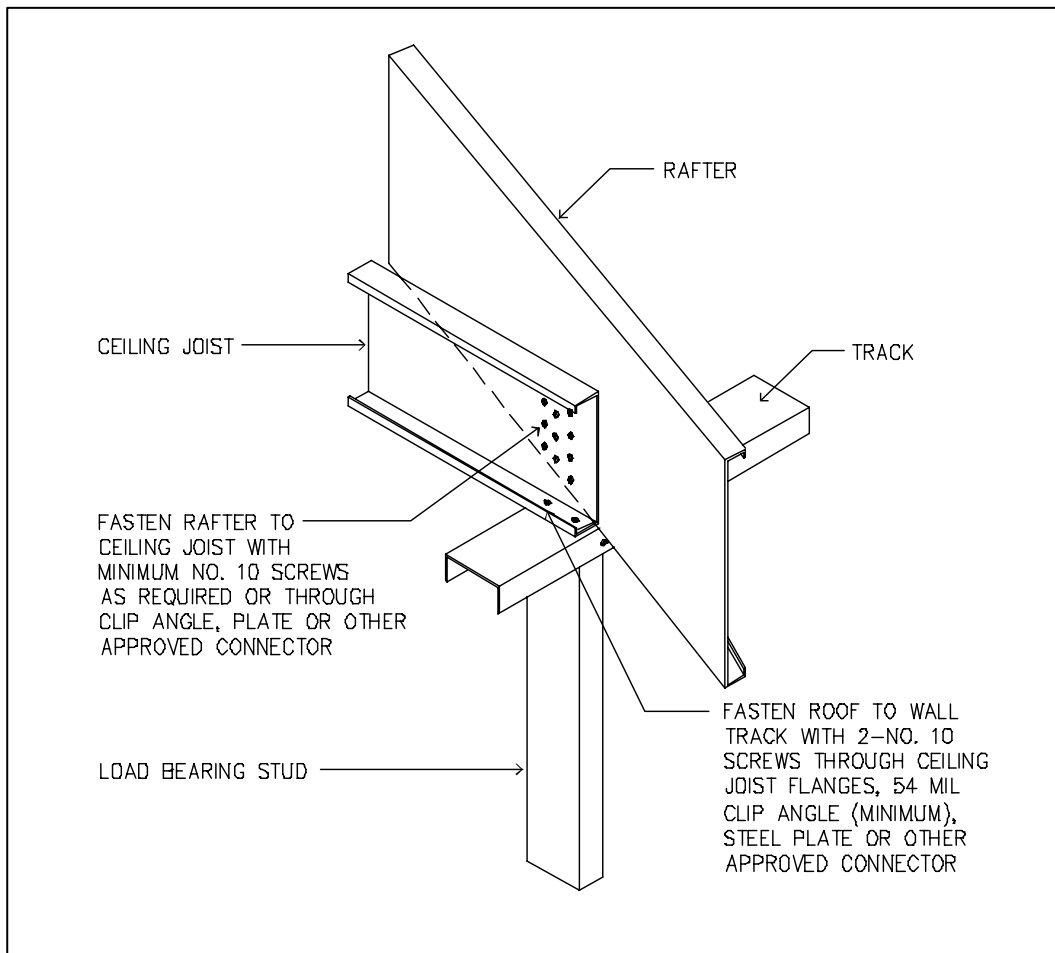

FIGURE R804.3.1.1(1)
JOIST TO RAFTER CONNECTION

28. Add new figures as follows:

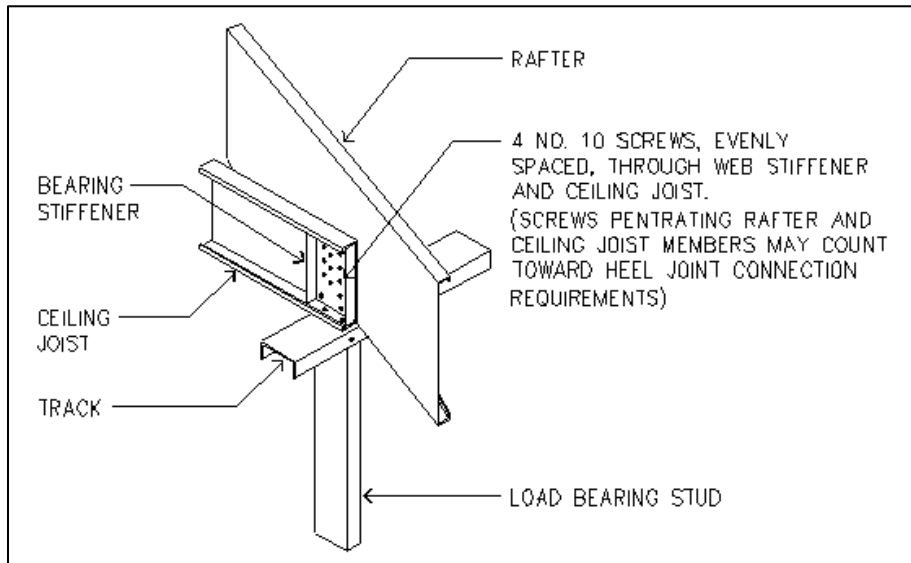

FIGURE R804.3.1.1(2)
BEARING STIFFENER

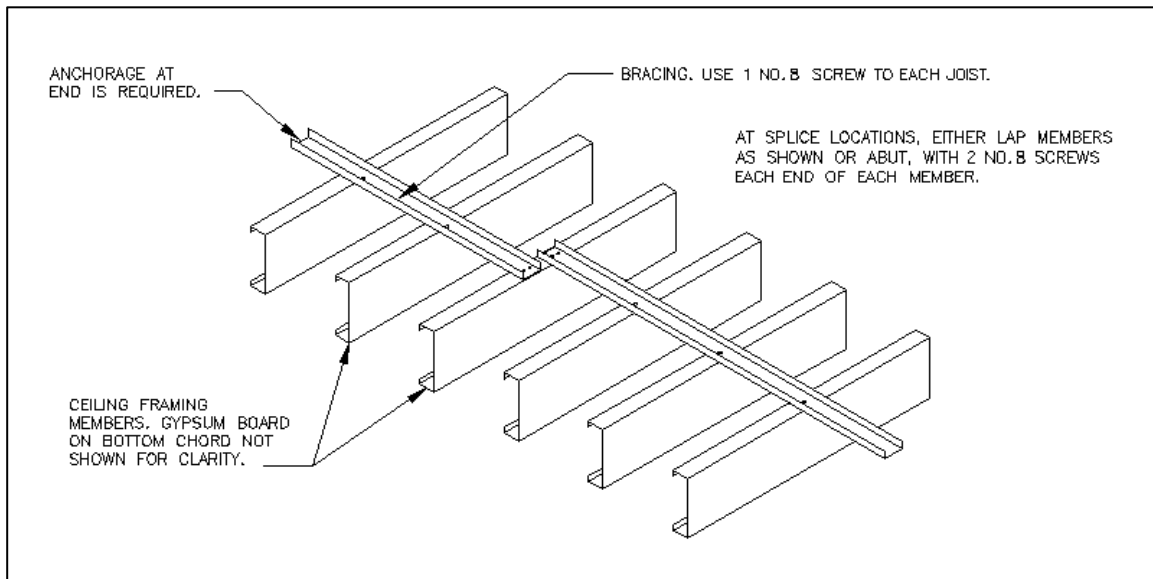

FIGURE R804.3.1.4(1)
CEILING JOIST TOP FLANGE BRACING WITH C-SHAPE, TRACK OR COLD-ROLLED CHANNEL

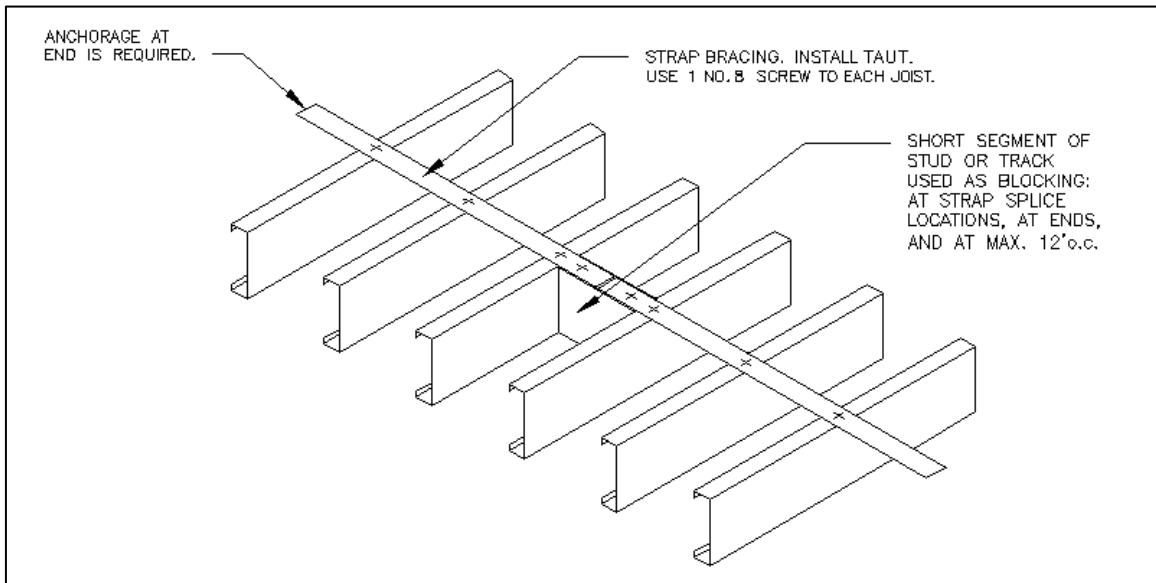

FIGURE R804.3.1.4(2)
CEILING JOIST TOP FLANGE BRACING WITH CONTINUOUS STEEL STRAP AND BLOCKING

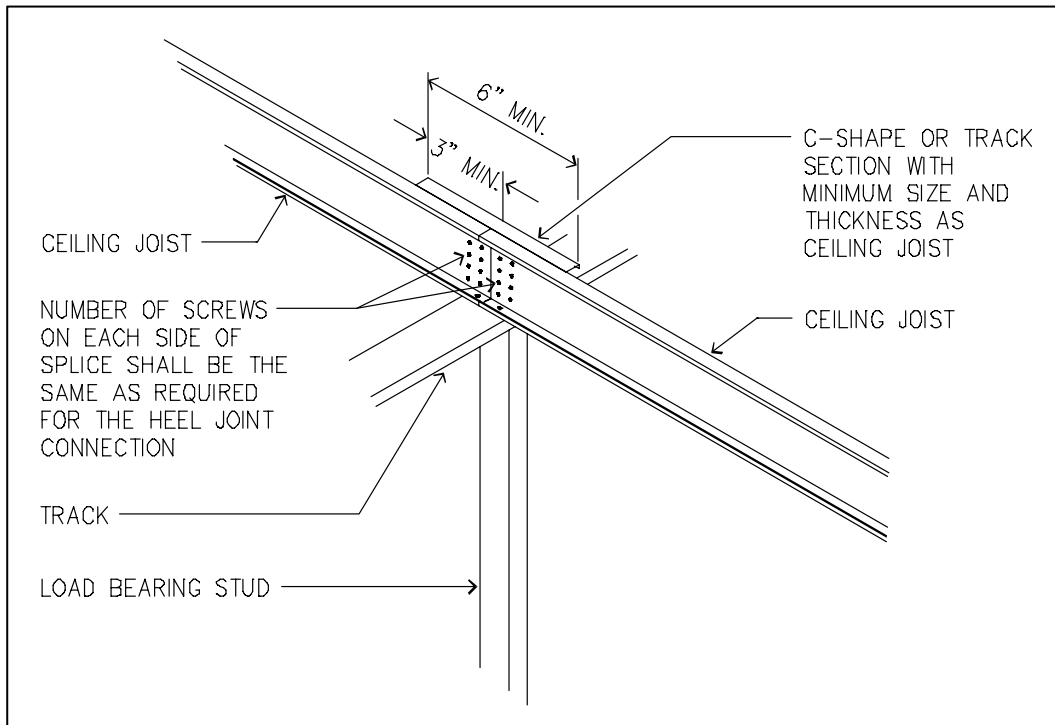
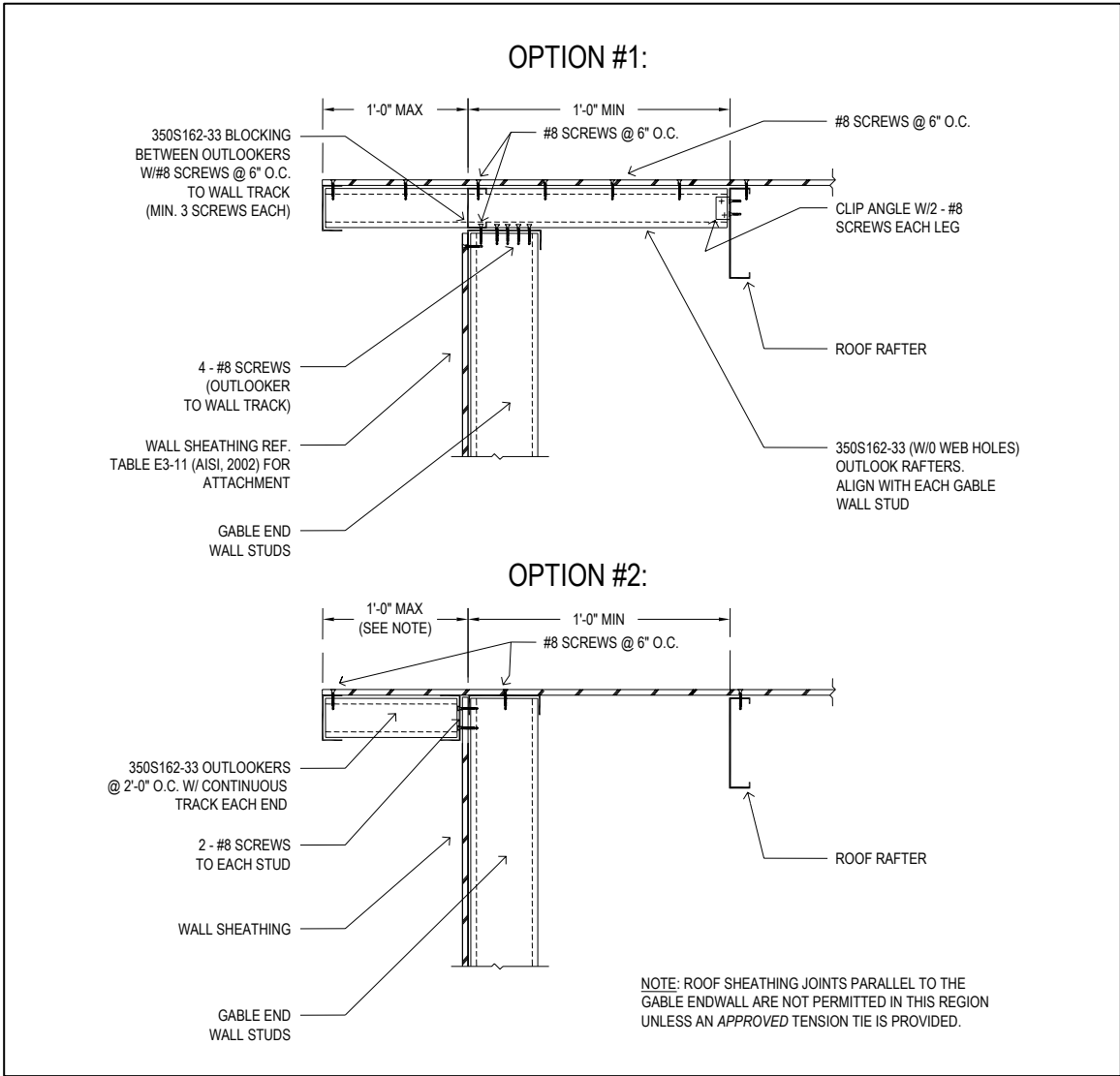

FIGURE R804.3.1.5
SPLICED CEILING JOISTS



**FIGURE R804.3.2.1.2
GABLE ENDWALL OVERHANG DETAILS**

29. Revise as follows:

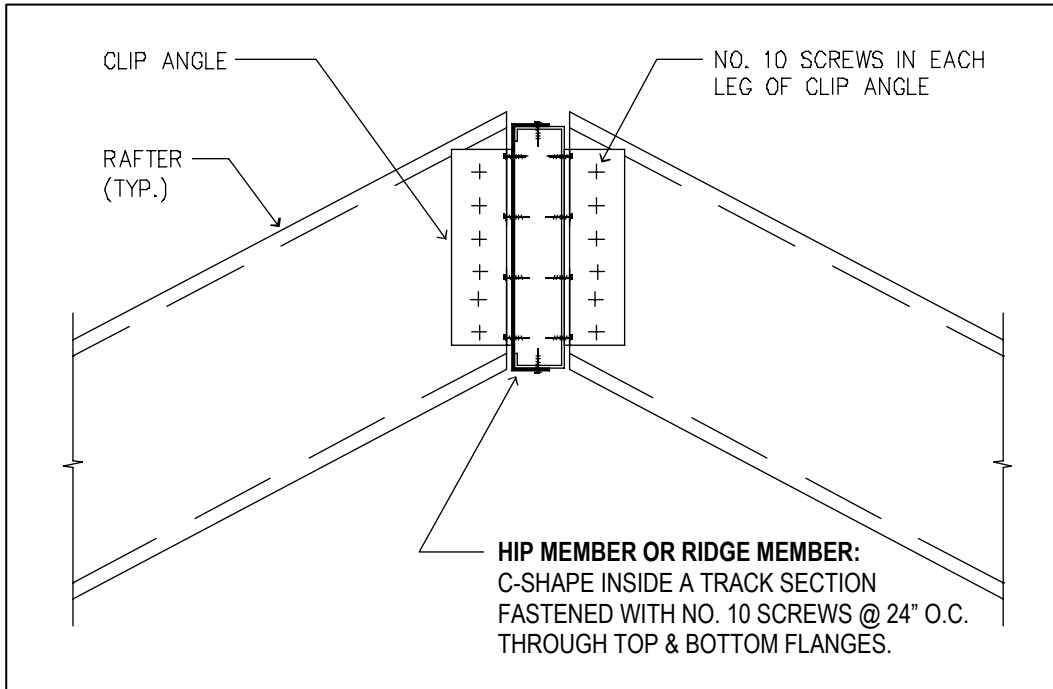

FIGURE R804.3.2.43.1
HIP MEMBER OR RIDGE BOARD MEMBER CONNECTION

30. Add new figures as follows:

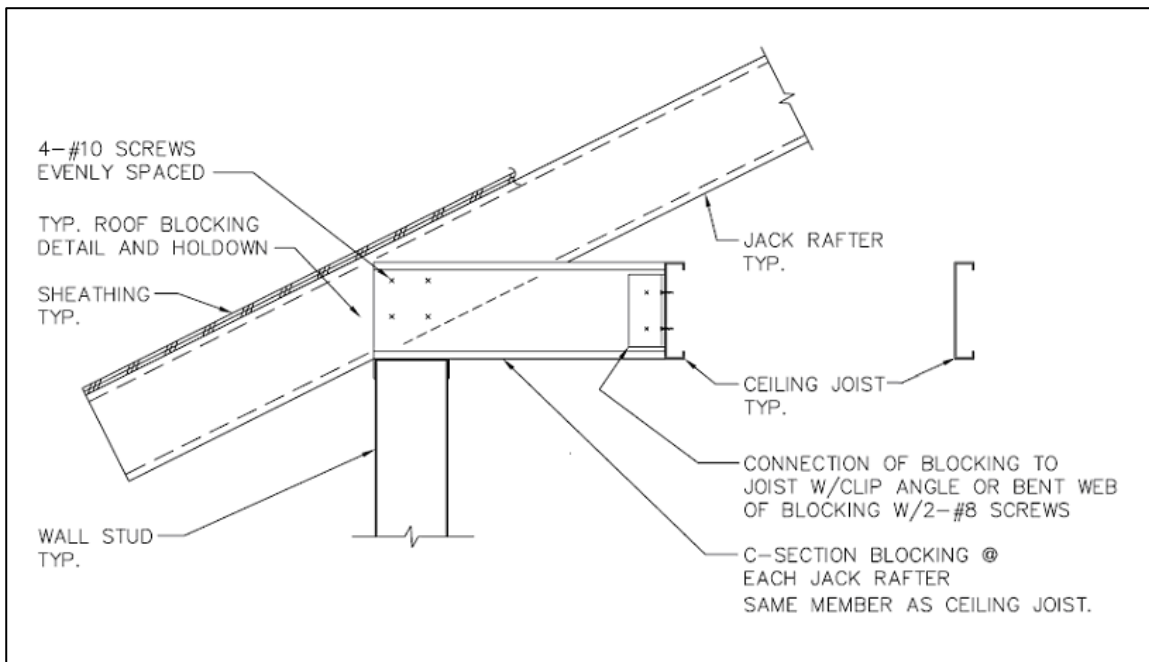

FIGURE R804.3.3.4(1)
JACK RAFTER CONNECTION AT EAVE

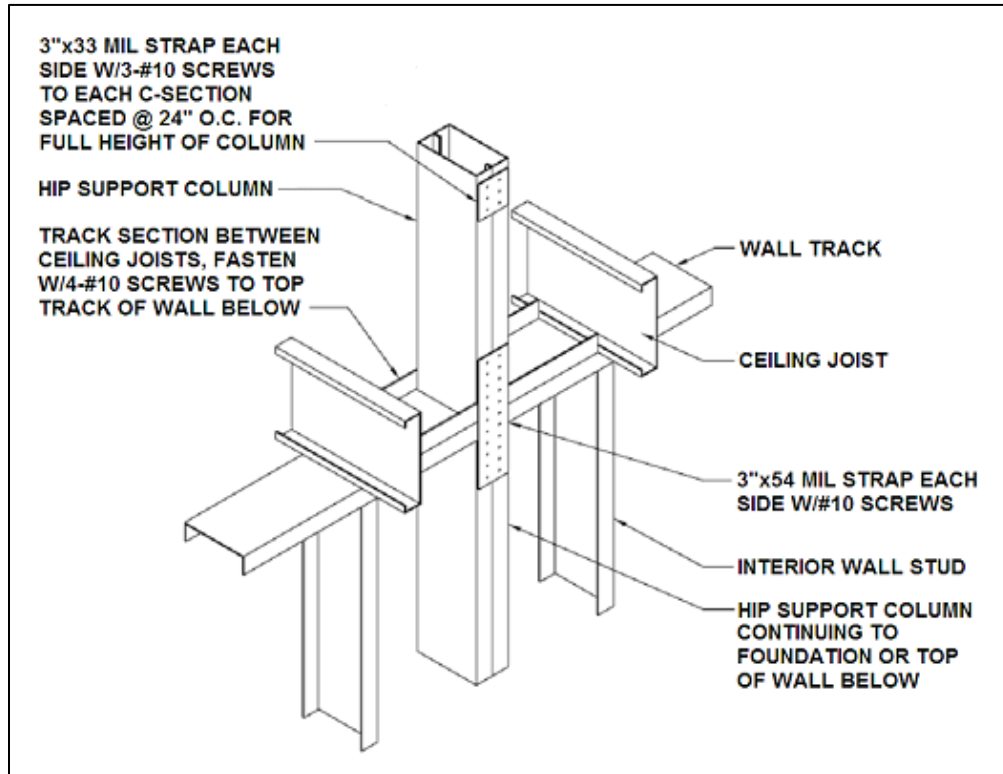

FIGURE R804.3.3.4(2)
HP SUPPORT COLUMN

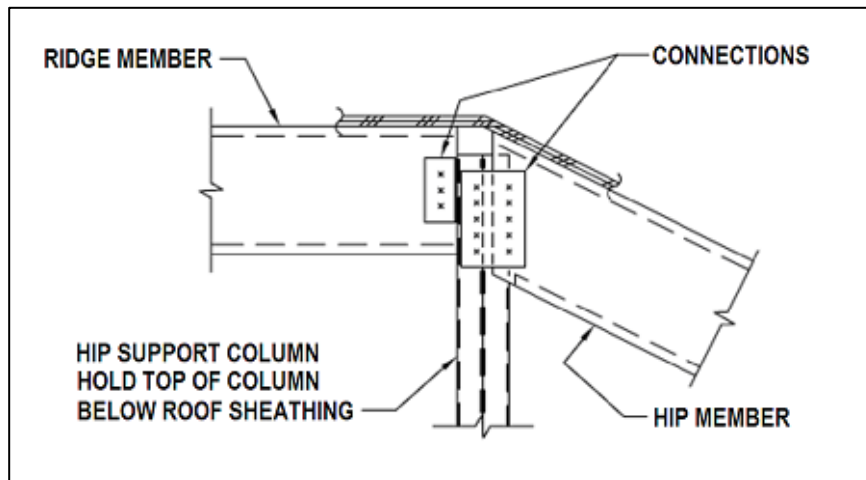

FIGURE R804.3.3.4(3)
HIP CONNECTIONS AT RIDGE

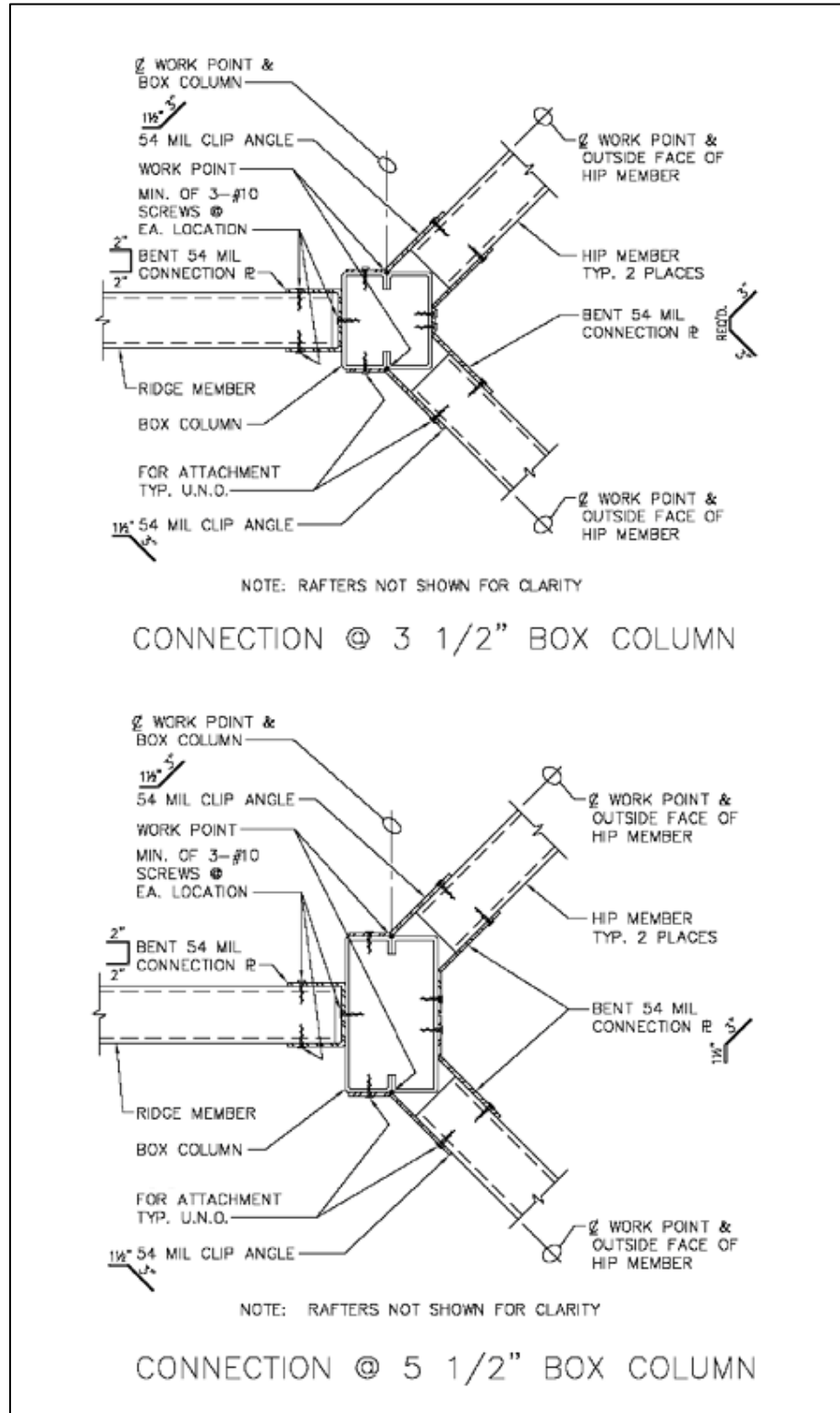

FIGURE R804.3.3.4(4)
HIP CONNECTIONS AT RIDGE AND BOX COLUMN

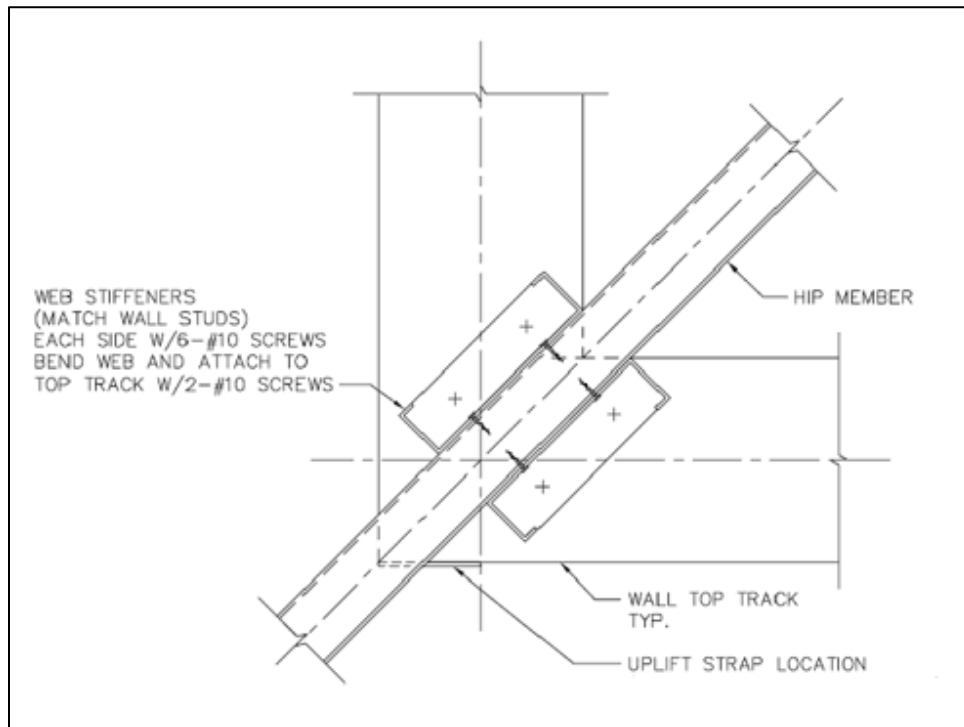

FIGURE R804.3.3.4(5)
HIP MEMBER CONNECTION AT WALL CORNER

31. Delete figures without substitution:

~~**FIGURE R804.3.6**~~
~~**HOLE PATCHING**~~

~~**FIGURE R804.3.7(1)**~~
~~**SPLICED CEILING JOIST**~~

~~**FIGURE R804.3.7(2)**~~
~~**TRACK SPLICE**~~

~~**FIGURE R804.3.8**~~
~~**BEARING STIFFENER**~~

32. Revise as follows:

~~**FIGURE R804.3.10(1)**~~ **R804.3.6(1)**
ROOF OR CEILING OPENING

(No change to figure)

33. Delete existing Figure R804.3.10(2) and substitute as follows:

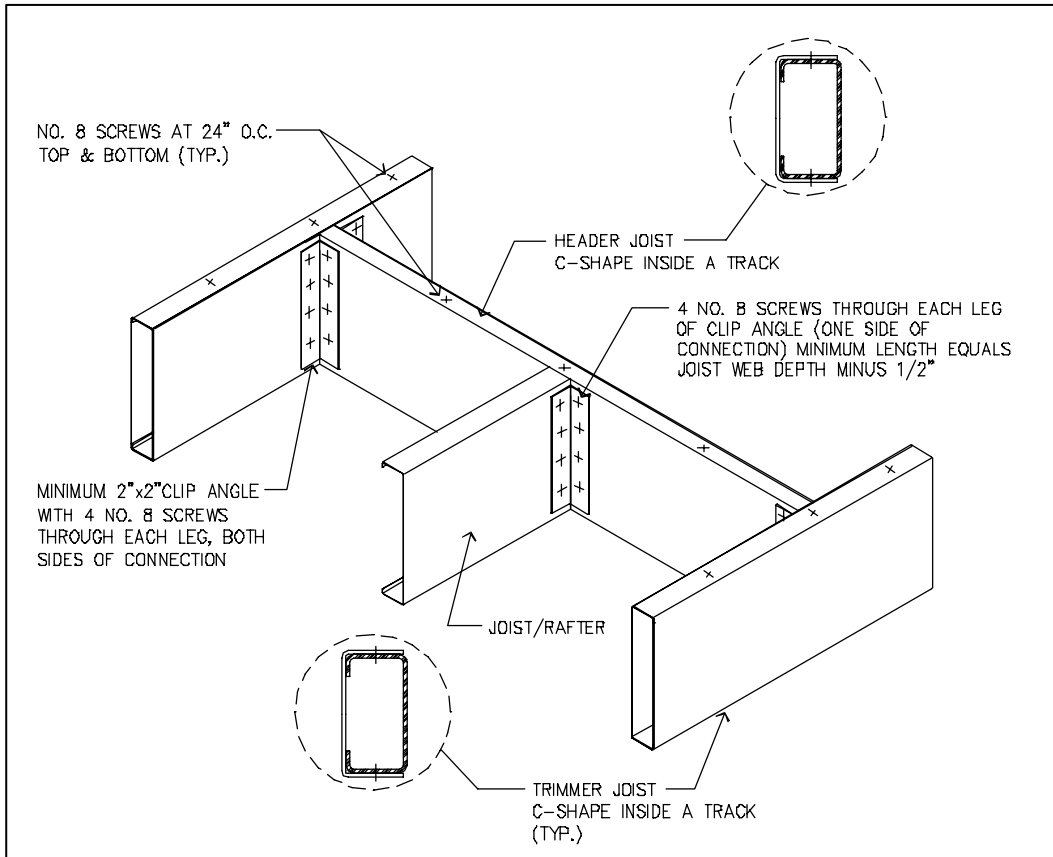

FIGURE R804.3.6(2)
HEADER TO TRIMMER CONNECTION

34. Add new figures as follows:

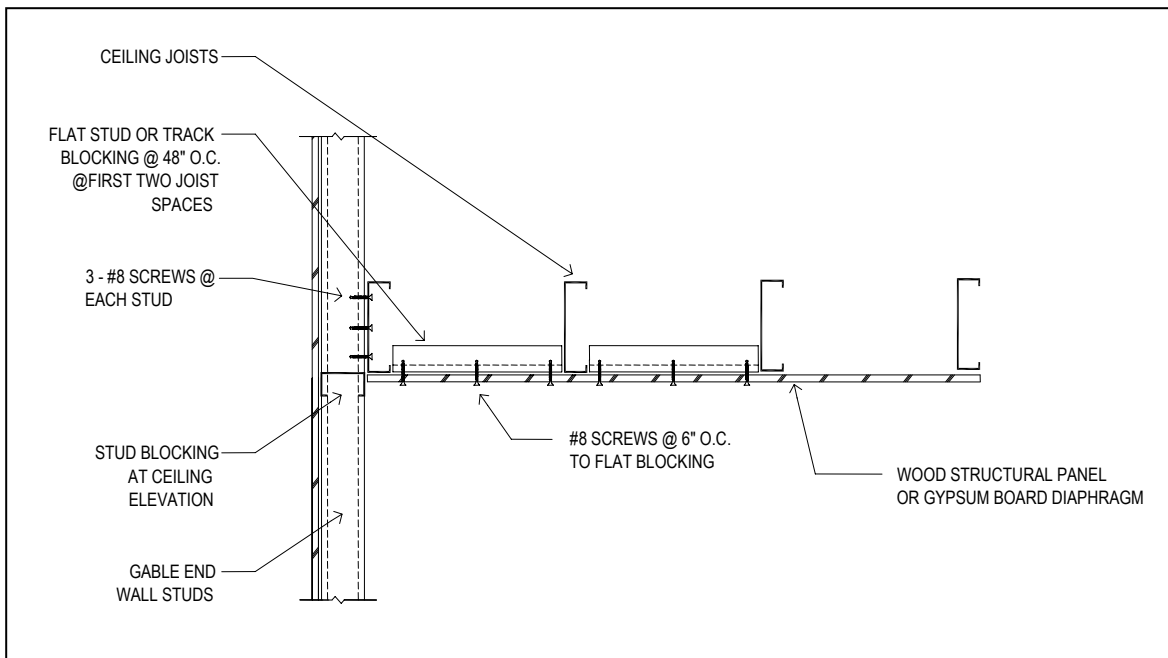

FIGURE R804.3.8(1)
CEILING DIAPHRAGM TO GABLE ENDWALL DETAIL

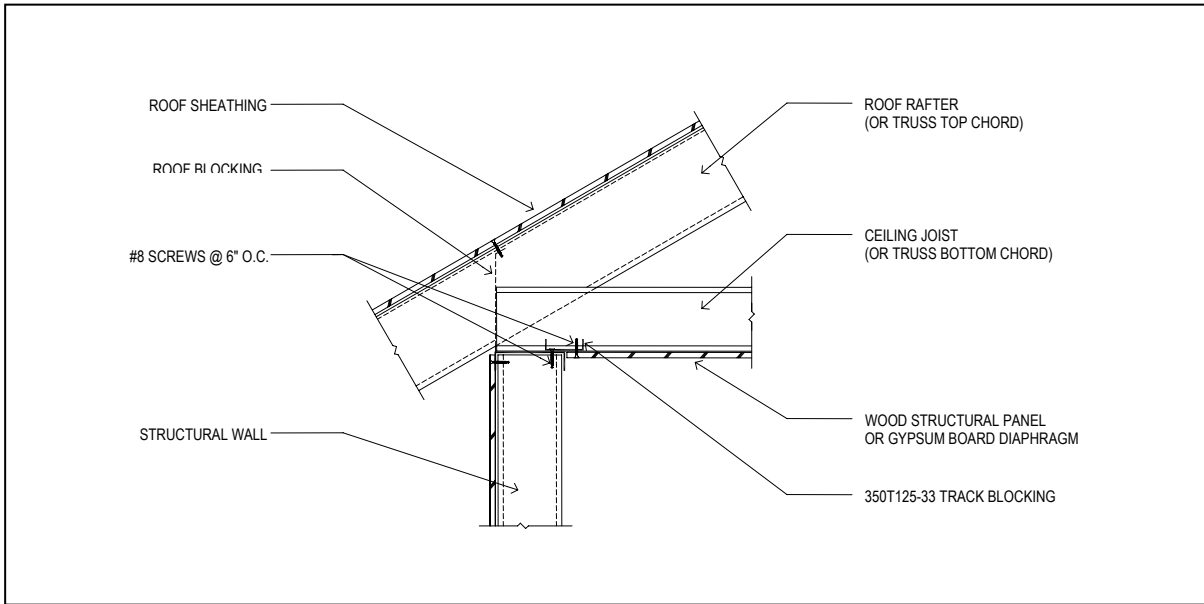

FIGURE R804.3.8(2)
CEILING DIAPHRAGM TO SIDEWALL DETAIL

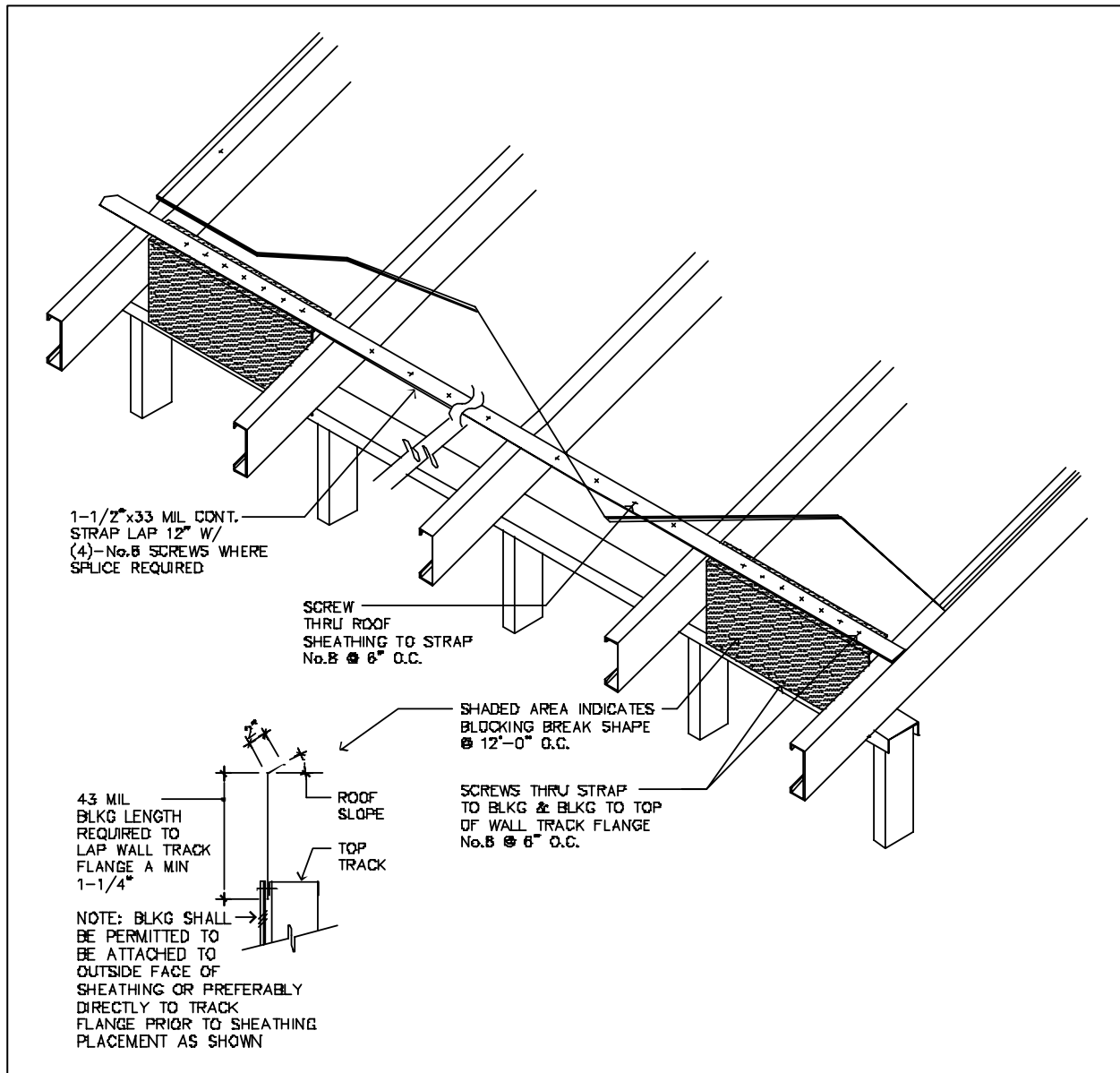

FIGURE R804.6(3)
ROOF BLOCKING DETAIL

35. Add standards to Chapter 43 as follows:

AISI

S100-07 North American Specification for the Design of Cold-Formed Steel Structural Members

ASTM

C 1513-04 Standard Specification for Steel Tapping Screws for Cold-Formed Steel Framing Connections

Reason: This code change updates the prescriptive requirements of International Residential Code, Section R804, to reflect the 2007 edition of AISI S230, *Standard for Cold-Formed Steel Framing -- Prescriptive Method for One- and Two-Family Dwellings*. The following substantive changes have been made to Section 804 (Steel Roof Framing):

PART 1: SECTION 804

Section R804.1.1: The 2007 edition of AISI S230 (*Standard for Cold-Formed Steel Framing -- Prescriptive Method for One and Two Family Dwellings*) increases the allowable number of stories from two to three stories. This modification is intended to coordinate with AISI S230.

Section R804.1.2: The 2007 edition of AISI S230 references the 2007 edition of AISI S200 (*North American Standard for Cold-Formed Steel Framing—General Provisions*) which has revised the in-line framing tolerance to account for the special case of the bearing stiffener located on the back-side of the joist. This was based on research at the University of Waterloo (Reference: Fox, S.R. (2003), "The Strength of Stiffened CFS Floor Joist Assemblies with Offset Loading," American Iron and Steel Institute, Washington, D.C.)

Section R804.2: Table R804.2(2) has been corrected to reflect industry standardized thicknesses for structural members. Additionally, a line has been added for 97 mils, since it is used extensively throughout the IRC. The column on Reference Gage Number has been deleted, since gage is no longer used by industry in referencing structural members. Finally, the topic of holes has been relocated to a new Section R804.2.5 on web holes, web hole reinforcement, and web hole patching. Accordingly, the associated Figure R804.2(3) has been renumbered to Figure R804.2.5.1, with no other changes to the figure.

Section R804.2.1: This section has been modified to coordinate with the 2007 edition of AISI S230, which now recognizes ASTM A 1003 as the primary standard for cold-formed steel light frame construction (via a reference to AISI S200). References to the ASTM A 1003 grades have been corrected to specify Structural Type H. Further, references to Grades 37 and 40 have been deleted, since these grades are not used by the IRC. Finally, the references to ASTM A 653 and ASTM A792 have been retained, since AISI S230 still considers them deemed-to-comply with ASTM A 1003. However, reference to ASTM A875 has been deleted, since it is no longer used in the construction marketplace.

Section R804.2.2: This section has been modified to reflect the change in terminology in Table R804.2(2) from "uncoated steel thickness" to "base steel thickness."

Section R804.2.3: This section has been modified to coordinate with the 2007 edition of AISI S230, which now recognizes ASTM A1003 as the primary standard for cold-formed steel light frame construction (via a reference to AISI S200). The reference to ASTM A875 has been deleted, since it is no longer used in the construction marketplace.

Section R804.2.4: This section has been modified to coordinate with the 2007 edition of AISI S230, which now recognizes ASTM C1513 (via a reference to AISI S200) in lieu of SAE J78. ASTM C1513 is the more appropriate consensus standard, which continues to charge SAE J78. The reference to ASTM B 633 has been deleted in favor of the substituted language from AISI S230.

Section R804.2.5.1: Section R804.2.5.1 has been created using existing IRC Section 804.2 in order to improve the clarity and usability of the code by locating all requirements concerning web holes and web hole adjustments in one central location. In addition, Figure R804.2(3) has been renumbered as Figure R804.2.5.1, with no other changes to the figure, as part of the coordination effort.

Section R804.2.5.2: New to the 2007 edition of AISI S230, this language permits the reinforcing of web holes, thus allowing the utility to remain, as long as the finished web hole meets the requirements of this subsection and that of Section R804.2.5.1. The provisions are based on engineering judgment and have been confirmed by preliminary testing.

Section R804.2.5.3: This language has been relocated from Section R804.3.6 in order to improve the clarity and usability of the code. Modifications have been made to the charging language to reflect the fact that the user now has the choice to reinforce non-conforming holes, patch non-conforming holes, or design non-conforming holes with accepted engineering practice per Section R804.2.5.1. Additionally, Figure R804.2.5.3 has been added as an update to the old Figure R804.3.6, in order to coordinate with AISI S230-07.

Section R804.3: This section has been modified substantially to reflect the latest provisions from AISI S230-07.

Section R804.3.1: This section on ceiling joists has been modified to improve its clarity and reflect the latest provisions from AISI S230-07. In particular, the topics of minimum ceiling joist size, ceiling joist bearing stiffeners, ceiling joist bottom flange bracing, ceiling joist top flange bracing and ceiling joist splicing have been relocated into their own individual sections to highlight the different requirements.

Section R804.3.2: This section on roof rafters has been modified to improve its clarity and reflect the latest provisions from AISI S230-07. In particular, the topics of minimum roof rafter size, roof rafter support brace, roof rafter splice, roof rafter to ceiling joist and ridge member connection, and roof rafter bottom flange bracing have been relocated into their own individual sections to highlight the different requirements.

Section R804.3.2.1: New sub-sections on eave overhangs and rake overhangs have been added. The section on rake overhangs addresses the lack of information on this subject in previous editions of the IRC and coordinates with AISI S230-07. In addition Figure R804.3.2.1.2 has been added to supplement this provision. Accordingly, Section R804.3.3.2 on roof cantilevers has been recommended for deletion.

Section R804.3.3: Cold-formed steel hip framing has been added to this section to cover a topic not previously addressed in the IRC. Although this topic is considered common practice and has been available to users through the AISI Prescriptive method in the past, the industry felt it time to integrate these provisions into the IRC to complete the prescriptive requirements in the roofing section. Along with provisions, this proposal also includes tables for framing member and fastening requirements, and includes figures demonstrating the various connections details.

Section R804.3.6: This section on hole patching has been relocated to new section R804.2.5.3 with all other provisions for web holes in framing members. As a result of this change, subsequent sections have been renumbered for coordination. In addition the associated figures and tables have also been renumbered for coordination.

Section R804.3.7: This section on splicing has been split and relocated to the applicable sections on ceiling joists and roof rafters. As a result of this change, subsequent sections have been renumbered for coordination.

Section R804.3.8: This section on bearing stiffeners has been updated extensively and relocated to the section on ceiling joists. As a result of this change, subsequent sections have been renumbered for coordination.

Section R804.3.5 (new): This section on roof-ceiling framing above wall openings has been updated to reflect changes proposed for IRC Section R603.

Section R804.3.6 (new): This section on framing of openings has been updated to reflect the latest provisions from AISI S230, including the addition of a new figure.

Section R804.3.7 (new): In 2007, the scope of AISI S100, *North American Specification for the Design of Cold-Formed Steel Structural Members*, Section D4 on Wall Studs and Wall Stud Assemblies was broadened to cover Cold-Formed Steel Light-Frame Construction. This was done in order to properly recognize the growing use of cold-formed steel framing in a broader range of residential and light commercial framing applications and to provide the appropriate charging language for the various ANSI approved standards that have been developed by the AISI Committee on Framing Standards. This proposal changes the reference from the too specific AISI Truss document (2004) to the more general, and correct, AISI S100, Section D4, which picks up the reference to the whole library of AISI cold-formed steel light frame construction.

New Section R804.3.8: This new section specifies requirements for the installation of ceiling diaphragms, such as gypsum board and wood panel sheathing. The provisions provide for both the generic prescriptive approach and an approach where, if other installation measures are applied, a reduction in the panel sizes is permitted. Additional tables and figures were added to correspond with the text provisions.

Table R804.2(2) has been both modified through the removal of the gauge category, and by adding a new category for 0.097 inch thick steel. The gauge category has been removed to reflect the steel industry's move away from this archaic designation.

Tables R804.3.2.1(1) and R804.3.2.1(2) are new tables on roof rafter spans.

Tables R804.3.3.2, R804.3.3.3, R804.3.3.4(1) through R804.3.3.4(3) are new tables for the requirements of hip roof configurations.

Tables R804.3.8(1) through R804.3.8(3) are new tables for the ceiling diaphragm requirements that correspond to the new provisions R804.3.8.

Figures R804.1.2, R804.2.5.3, R804.3.1.1(1), and R804.3.1.1(2) are replacement figures which contain new information on screw types, additional cross sectional illustrations, and other applicable information.

Figures R804.3.1.4(1) and R804.3.1.4(2) illustrate new options for ceiling joist top flange bracing.
 Figure R804.3.1.5 illustrates a new detail for spliced ceiling joints from AISI S230-07.
 Figure R804.3.2.1.2 illustrates gable end wall and outlookers overhang details.
 Figures R804.3.2.4 is a replacement figure that illustrates newer information on screw types and cross section details for clarity.
 Figures R804.3.3.4(1) through R804.3.3.4(5) are new figures that correspond to the new hip roof provisions for this proposal. These include various views for the construction of hip roof intersections with the building framing (e.g. walls, ceiling joists, and rafters).
 Figure R804.3.6(2) illustrates a new header to trimmer connection.
 Figures R804.3.8(1) through R804.3.8(3) are new figures that illustrate cross-sections of the intersection of the ceiling diaphragm with the perimeter wall. These figures correspond with new Section R804.3.8.

PART 2, CHAPTER 43

Chapter 43: The modifications to add reference standards in Chapter 43 are coordinated with changes made to Section R804.

Cost Impact: The code change proposal will not increase the cost of construction.

Errata: Change Section R804.1.2 to read as shown:

R804.1.2 In-line framing. Cold-formed steel roof framing constructed in accordance with Section R804 shall be located directly in line with load-bearing studs in accordance with Figure R804.1.2 and the tolerances specified in Section R804.1.2(a) or R804.1.2(b) and with Figure R804.1.2 as follows:

1. ~~with a~~ The maximum tolerance shall be of 3/4 inch (19.1 mm) between the centerline of the horizontal framing member and the centerline of the vertical framing member between the center line of the stud and the roof joist/rafter.
2. Where the centerline of the horizontal framing member and bearing stiffener are located to one side of the center line of the vertical framing member, the maximum tolerance shall be 1/8 inch (3 mm) between the web of the horizontal framing member and the edge of the vertical framing member.

Errata: Change Section R804.2.5.3 to read as shown:

R804.2.5.3 Hole patching. Web holes in roof framing members not conforming to the requirements in Section R804.2.5.1 shall be permitted to be patched in accordance with either of the following methods:

1. Framing members shall be replaced or designed in accordance with accepted engineering practices where web holes exceed the following size limits:
 - 1.1. The depth of the hole, measured across the web, exceeds 70 percent of the flat width of the web; or
 - 1.2. The length of the hole measured along the web, exceeds 10 inches (254 mm) or the depth of the web, whichever is greater.
2. Web holes not exceeding the dimensional requirements in Section R804.2.5.3, Item 1, shall be patched with a solid steel plate, stud section, or track section in accordance with Figure R804.2.5.3. The steel patch shall, as a minimum, be of the same thickness as the receiving member and shall extend at least 1 inch (25 mm) beyond all edges of the hole. The steel patch shall be fastened to the web of the receiving member with No.8 screws spaced no greater than 1 inch (25 mm) center-to-center along the edges of the patch with minimum edge distance of 1/2 inch (13 mm).

Errata: Change Table R804.3.8(3) to read as shown:

TABLE R804.3.8(3)
REQUIRED LENGTHS FOR CEILING DIAPHRAGMS AT GABLE ENDWALLS
WOOD STRUCTURAL PANEL SHEATHED
CEILING HEIGHT = 8, 9 OR 10 ft ^{a,b,c,d,e,f}

(No change to proposed table or footnotes)

Analysis: Review of proposed new standards AISI S100-07 and ASTM C 1513-04 indicated that, in the opinion of ICC Staff, the standard did comply with ICC standards criteria.

Committee Action:

Approved as Submitted

Committee Reason: This change updates the prescriptive provisions for cold-formed steel roof framing to the current standards.

Assembly Action:

None

Individual Consideration Agenda

This item is on the agenda for individual consideration because a public comment was submitted.

Public Comment:

Bonnie Manley, American Iron and Steel Institute, requests Approval as Modified by this Public Comment.

Modify proposal as follows:

R804.1.1 Applicability limits. The provisions of this section shall control the construction of cold-formed steel roof framing for buildings not greater than 60 feet (18 288 mm) perpendicular to the joist, rafter or truss span, not greater than 40 feet (12 192 mm) in width parallel to the joist span or truss, less than or equal to three stories above grade plane in height and with roof slopes not smaller than 3:12 (25-percent slope) or greater than 12:12 (100 percent slope). Cold-formed steel roof framing constructed in accordance with the provisions of this section shall be limited to sites subjected to a maximum design wind speed of 110 miles per hour (49 m/s), Exposure A, B, or C, and a maximum ground snow load of 70 pounds per square foot (3350 Pa).

R804.2 Structural framing. Load-bearing cold-formed steel roof framing members shall comply with Figure R804.2(1) and with the dimensional and minimum thickness requirements specified in Tables R804.2(1) and R804.2(2). Tracks shall comply with Figure R804.2(2) and shall have a minimum flange width of 1 1/4 inches (32 mm). The maximum inside bend radius for members shall be the greater of 3/32 inch (2.4 mm) minus half the base steel thickness or twice 1.5 times the base steel thickness.

(Portions of these tables and footnotes not shown remain unchanged)

**TABLE R804.3.2.1(3)
BASIC WIND SPEED TO EQUIVALENT SNOW LOAD CONVERSION**

BASIC WIND SPEED AND EXPOSURE		EQUIVALENT GROUND SNOW LOAD (psf)									
		Roof Slope									
Exp. A/B	Exp. C	3:12	4:12	5:12	6:12	7:12	8:12	9:12	10:12	11:12	12:12

**TABLE 804.3.3.4(1)
UPLIFT STRAP CONNECTION REQUIREMENTS
HIP SUPPORT COLUMN AT CEILING LINE**

BASIC WIND SPEED (MPH) Exposure B					
	85	100	110	-	-
BASIC WIND SPEED (MPH) Exposure C					
	-	85	-	100	110

**TABLE 804.3.3.4(3)
UPLIFT STRAP CONNECTION REQUIREMENTS
HIP MEMBER TO WALL**

BASIC WIND SPEED (MPH) Exposure B					
	85	100	110	-	-
BASIC WIND SPEED (MPH) Exposure C					
	-	85	-	100	110

**TABLE R804.3.8(1)
REQUIRED LENGTHS FOR CEILING DIAPHRAGMS AT GABLE ENDWALLS
GYPSUM BOARD SHEATHED
CEILING HEIGHT = 8 ft^{a,b,c,d,e,f}**

Exposure A/B	BASIC WIND SPEED (mph)				
		85	100	110	-

**TABLE R804.3.8(2)
REQUIRED LENGTHS FOR CEILING DIAPHRAGMS AT GABLE ENDWALLS
GYPSUM BOARD SHEATHED
CEILING HEIGHT = 9 or 10 ft^{a,b,c,d,e,f}**

Exposure A/B	BASIC WIND SPEED (mph)				
		85	100	110	-

**TABLE R804.3.8(3)
REQUIRED LENGTHS FOR CEILING DIAPHRAGMS AT GABLE ENDWALLS
WOOD STRUCTURAL PANEL SHEATHED
CEILING HEIGHT = 8, 9 OR 10 ft^{a,b,c,d,e,f}**

Exposure A/B	Basic Wind Speed (mph)				
		85	100	110	-

Commenter's Reason: In Section R804.1.1, the addition of "cold-formed" in the first sentence is editorial. The change from "in height" to "above grade plane" is to maintain consistency with terminology already used throughout the IRC. Additionally, the reference to wind Exposure A has been eliminated, since it is no longer defined in ASCE 7-05.

In Section R804.2, the addition of "cold-formed" is editorial and the other modification corrects the maximum inside bend radius to reflect the latest requirements found in AISI S201-07, *North American Standard for Cold-Formed Steel Framing – Product Data*, which is referenced in the adopted AISI S230-07.

The modifications to the Tables are editorial in nature and include deleting the reference to wind Exposure A, since it is no longer defined in ASCE 7-05.

Final Action: AS AM AMPC_____ D

RB210-07/08

R806.2

Proposed Change as Submitted:

Proponent: Jim Kessler, City of Northfield, MN

Revise as follows:

R806.2 (Supp) Minimum area. The total net free ventilating area shall not be less than 1/150 of the area of the space to be ventilated with at least 50 percent of the ventilation in the upper half of the ventilated area. ~~except that~~

Exceptions:

1. Reduction of the total area to 1/300 is permitted, provided that at least 50 percent and not more than 80 percent of the required ventilating area is provided by ventilators located in the upper ~~portion~~ half of the space to be ventilated ~~at least 3 feet (914 mm) above the eave or cornice vents~~ with the balance of the required ventilation provided by eave or cornice vents.
2. ~~As an alternative, The total net free cross-ventilation~~ ventilating area may be reduced to 1/300 when a Class I or II vapor barrier having a transmission rate not exceeding 1 perm (5.7 x 10⁻¹¹ kg/s•m²•Pa) is installed on the warm-in-winter side of the ceiling. At least 50 percent of the ventilating area must be in the upper half of the ventilated area.

Reason: To clarify the code.

The existing language for 1 to 150 does not clarify where the vents should be located. A contractor could place all the vents in the soffit and be in compliance. We had an architect state he wanted no roof vents and was going to comply using soffit vents.

The existing 3-foot requirement would not be appropriate in a shallow sloped roof.

The existing exception (alternative) is not clear that venting is still required in the upper portion of the roof. The term "cross-ventilation" has an implication but is not clarified. A contractor could comply by using only soffit vents.

Cost Impact: The code change proposal will not increase the cost of construction.

Committee Action:

Disapproved

Committee Reason: This proposal would add much more restrictive requirements without any substantial technical justification.

Assembly Action:

None

Individual Consideration Agenda

This item is on the agenda for individual consideration because a public comment was submitted.

Public Comment:

Scott Dornfeld, City of Delano, MN, representing the Association of Minnesota Building Officials, requests Approval as Modified by this Public Comment.

Modify proposal as follows:

R806.2 (Supp) Minimum area. The total net free ventilating area shall not be less than 1/150 of the area of the space to be ventilated with at least 50 percent of the ~~ventilation~~ ventilated area in the upper half ~~to be in the upper~~ 1/3 of the ventilated area.

Exceptions:

1. Reduction of the total area to 1/300 is permitted, provided that at least 50 percent and not more than 80 percent of the required ventilating area is provided by ventilators located in the upper ~~half~~ 1/3 of the space to be ventilated with the balance of the required ventilation provided by the eave or cornice vents.
2. The total net free ventilating area may be reduced to 1/300 when a vapor barrier having a transmission rate not exceeding 1 perm (5.7 x 10⁻¹¹ kg/s•m²•Pa) is installed on the warm-in-winter side of the ceiling. At least 50 percent of the ventilating area must be in the upper ~~half~~ 1/3 of the ventilated area.

Commenter's Reason: With the wording clarification, I believe this should help clear up many questions as to where on the roof the vents should go. This will allow the air to circulate freely as it should, in most roof assemblies. This should be seen as an editorial clarification.

Final Action:

AS

AM

AMPC____

D

RB212-07/08

R806.5 (New)

Proposed Change as Submitted:

Proponent: Dwight Sheldon, Demilec (USA) LLC, representing himself

Add new text as follows:

R806.5 Unvented single rafter roof assemblies. Unvented single rafter (“vaulted” or “cathedral”) roof assemblies shall be permitted if all the following conditions are met:

1. A minimum insulation level of R-20 air-impermeable insulation shall be installed above all recessed fixtures such as recessed lights, ducts and exhaust fans.
2. Where wood shingles or shakes are used, a minimum ¼ inch (6 mm) vented air space separates the shingles or shakes from the roofing underlayment.
3. Either 3.1, 3.2 or 3.3 shall be met, depending on the air-permeability of the insulation under the structural roof sheathing.
 - 3.1. Air-impermeable insulation only. Insulation shall be applied in direct contact to the underside of the structural roof sheathing.
 - 3.2. Air-permeable insulation only. In addition to air-permeable insulation installed directly below the structural sheathing, air-impermeable spray foam, rigid board or sheet insulation shall be installed directly above the structural roof sheathing to a minimum insulation level of R-20 for condensation control.
 - 3.3. Air-impermeable and air-permeable insulation. The air-impermeable insulation shall be applied in direct contact to the underside of the structural roof sheathing to a minimum insulation level of R-20 for condensation control. If preformed insulation board is used as the air-impermeable layer, it shall be caulked and sealed to form a continuous air barrier. The air-permeable insulation shall be installed in direct contact with the air-impermeable insulation.

Reason: This code change proposal fills a gap in the current code. It follows much of the intent of Section R806.4 and adds a provision for insulating above recessed lights and other devices installed in single-rafter roof assemblies.

The performance of this assembly is nearly identical to that of an unvented attic.

Cost Impact: The code change proposal will not increase the cost of construction.

Committee Action:

Disapproved

Committee Reason: There is no substantiation for the insulation level of R-20. This is not ready and needs to be reworked and brought back.

Assembly Action:

None

Individual Consideration Agenda

This item is on the agenda for individual consideration because a public comment was submitted.

Public Comment:

Dwight Sheldon, Oregon City, OR, requests Approval as Modified by this Public Comment.

Modify proposal as follows:

~~**R806.5 Unvented single rafter roof assemblies.** Unvented single rafter (“vaulted” or “cathedral”) roof assemblies shall be permitted if all the following conditions are met:~~

Unvented roof/ceiling assemblies. Unvented roof/ceiling assemblies (“vaulted” or “cathedral”) not meeting the definition of attic assemblies, shall be permitted if all of the following are met:

1. A minimum insulation level of R-20 as specified in Table R806.4 of air-impermeable insulation shall be installed above all recessed fixtures such as including recessed lights luminaries, ducts and exhaust fans.
2. Where wood shingles or shakes are used, a minimum ¼ inch (6 mm) vented air space separates the shingles or shakes from the roofing underlayment.
3. Either 3.1, 3.2 or 3.3 shall be met, depending on the air-permeability of the insulation under the structural roof sheathing.

- 3.1. Air-impermeable insulation only. Insulation shall be applied in direct contact to the underside of the structural roof sheathing.
- 3.2. Air-permeable insulation only. In addition to air-permeable insulation installed directly below the structural sheathing, air impermeable spray foam, rigid board or sheet insulation shall be installed directly above the structural roof sheathing to a minimum insulation level of R-20 as specified in Table R806.4 for condensation control.
- 3.3. Air-impermeable and air-permeable insulation. The air-impermeable insulation shall be applied in direct contact to the underside of the structural roof sheathing to a minimum insulation level of R-20 as specified in Table R806.4 for condensation control. If preformed insulation board is used as the air-impermeable layer, it shall be caulked and sealed to form a continuous air barrier. The air-permeable insulation shall be installed in direct contact with the air-impermeable insulation.

Commenter's Reason: This code change proposal fills a gap in the IRC. When originally proposed it used the term "single rafter roof assembly" which was challenged as unconventional. This revision changes the description to more conventional language.

Unvented attics are defined in section R-806.4, but unvented cathedral or vaulted ceilings are not specified. This code change proposal fills that gap and also provides for a minimum amount of air impermeable insulation to be applied above any fixture that is installed in the roof/ceiling assembly. Air impermeable insulation above the fixture is required to reduce the convective heat transfer as well as the conductive heat transfer in order to control condensation on the underside of the roofdeck.

Final Action: AS AM AMPC____ D

RB213-07/08

R807.1

Proposed Change as Submitted:

Proponent: Rick Davidson, City of Maple Grove, MN, representing the Association of Minnesota Building Officials (AMBO)

Revise as follows:

R807.1 (Supp) Attic access. Buildings with combustible ceiling or roof construction shall have an attic access opening to attic areas that exceed 30 square feet (2.8 m²) and have a vertical height of 30 inches (762 mm) or greater. The vertical height shall be measured from the top of the ceiling framing members to the underside of the roof framing members.

The rough-framed opening shall not be less than 22 inches by 30 inches (559 mm by 762 mm) and shall be located in ~~a hallway or other readily accessible location~~ an approved location. When located in a wall, the opening shall be a minimum of 22 inches wide by 30 inches high. When located in a ceiling, a 30-inch (762 mm) minimum unobstructed headroom in the attic space shall be provided at some point above the access measured vertically from the bottom of ceiling framing members. See Section M1305.1.3 for access requirements where mechanical equipment is located in attics.

Reason: This proposal was approved by the IRC Committee in Orlando. An unsuccessful modification to the proposal was heard in Rochester and then the strong fire presence in the audience argued that the access needed to be in a hallway for fire department access and the entire proposal was lost.

Unfortunately there was much information lacking prior to the vote. It must be remembered that the IBC is silent on the matter of the attic access location. Thus the IRC is more restrictive in its requirements. The reference to "hallway" makes a strong suggestion that the access must be in an interior location when access through a garage attic, a knee wall (for 1 ½ story designs), or an exterior location may be desirable. The revised text allows the access to be in any location provided the building official approves it. That will allow the building official the opportunity to review the proposed location to determine if it is useable and give greater flexibility as well. This text is also more consistent with generally used code language.

Ironically an exterior location is obviously more accessible and safer for the fire department than an interior location. A ladder short enough to provide access in a hallway is seldom carried on today's fire trucks while those in a gable would be more easily and more safely accessed using standard fire ladders.

Furthermore, it is important that the purpose of this code requirement is established as *not* for fire department access. The opening is not large enough for fire fighter access and acknowledging that the purpose is for fire fighter access opens the door to larger opening requirements.

The IRC Commentary states: "The requirement for an attic access is predicated on the likelihood that during the life of the structure, access to an attic space for repair of piping, electrical and mechanical systems will be required."

There is no suggestion that the purpose is for fire department access.

Cost Impact: The code change proposal will not increase the cost of construction.

Committee Action:

Disapproved

Committee Reason: The code already indicates that the attic access must be installed in a readily accessible location. Having the Building Official determine the location would remove the design flexibility.

Assembly Action:

None

Individual Consideration Agenda

This item is on the agenda for individual consideration because a public comment was submitted.

Public Comment:

Rick Davidson, City of Maple Grove, MN, representing the Association of Minnesota Building Officials, requests Approval as Submitted.

Commenter's Reason: The whole purpose of this code change was to make it apparent that the attic access could be located somewhere other than an interior hallway. While the code does provide the term "other readily accessible location", the implication remains that the access be interior and highly visible.

Although the IRC Committee approved this code change during the last cycle, they balked at the proposed language this time with the argument that they didn't want the authority having jurisdiction telling builders where the access could go. That argument is misdirected. The building official currently interprets what "other readily accessible location" means, not the builder. The current language unnecessarily limits the building official by directing that the access be in an interior location when access through a garage attic or from the exterior may prove to be more desirable.

The proposed language does not require that the building official dictate the location of the attic access, as the committee charges. He only need approve its location without the extra baggage created by the current language.

Most builders will realize that this proposal will give them and building officials greater flexibility in locating attic accesses.

An important reminder, the IBC is silent on the matter of the location of the attic access. The location requires no approval by the building official and can be wherever the owner/contractor wants it to be.

Final Action: AS AM AMPC____ D

RB215-07/08
R905.2.8.4

Proposed Change as Submitted:

Proponent: Gerald Anderson, City of Overland Park, KS, representing himself

Revise as follows:

R905.2.8.4 Sidewall flashing. Flashing against a vertical sidewall shall be by the step-flashing method. The flashing shall be a minimum of 4 inches (102 mm) high and 4 inches (102 mm) wide. At the end of the wall and roof intersection the flashing shall be turned out in order to direct water away from the wall and onto the roof and/or gutter.

Reason: This code change establishes a minimum size for the step flashing. What we are currently seeing in many situations is that roofers are creating the step flashing with a piece of 5 inch flashing. The end result is that you have at best a 2 1/2" vertical rise and a 2 1/2" deck flange. While flashing of this size maybe adequate to protect against normal water back up, it is inadequate when considering that most types of wood siding must be held off the roof surface 2 inches. As I understand it ARMA (Asphalt Roofing manufacture's Association) recommends a 5" high and 5" wide flashing, while NCRA (National Roofing Contractor's Associations) recommends a 4 " high and 4" wide flashing.

In order to properly flash the roof /vertical wall intersection the weather resistive barrier and the exterior siding must extend down over the metal flashing. A flashing with a minimum height of 4 inches would allow this to be done correctly.

The last sentence addresses the need for a "kick out" flashing which will divert the water away from the wall and back towards the roof. This is standard practice for stucco walls. It needs to be standard practice for all type of exterior siding. It is really a means of protecting (properly flashing) the wall at the end point.

Cost Impact: The code change proposal will not increase the cost of construction.

Committee Action: **Disapproved**

Committee Reason: The committee is not sure that one prescriptive size will accommodate all situations. Not sure what is meant by the end of the wall and roof intersection. What is meant by "turned out"? Does not address all three dimensions, height, width and length.

Assembly Action: **None**

Individual Consideration Agenda

This item is on the agenda for individual consideration because a public comment was submitted.

Public Comment:

Gerald Anderson, City of Overland Park, KS, representing himself, requests Approval as Modified by this Public Comment.

Modify proposal as follows:

R905.2.8.4 Sidewall flashing. Flashing against a vertical sidewall shall be by the step-flashing method. The flashing shall be a minimum of 4 inches (102 mm) high and 4 inches (102 mm) wide. At the end of the vertical sidewall and roof intersection the step flashing shall be turned out in such a manner so as in order to direct water away from the wall and onto the roof and/or gutter.

Commenter's Reason: This code change does not set forth one prescriptive size, as purported in the committee's reason statement. This code change does accomplish two things. First it establishes a minimum width and height for step flashing. The length as mentioned by the committee is unimportant. As I understand it ARMA (Asphalt Roofing manufacture's Association) recommends a 5" high and 5" wide flashing, while NCRA (National Roofing Contractor's Associations) recommends a 4 " high and 4" wide flashing. I have chosen the lesser of the two requirements simply because the IRC is a minimum code. A 4 inch height will allow enough distance to properly extend the weather resistive barrier and exterior siding over the metal flashing while maintaining at least a two inch gap between the bottom of the flashing and the siding. Secondly, this code change indicates how the step flashing is to be terminated. The last sentence addresses the need to properly terminate the sidewall flashing in a manner which will divert the water away from the wall and back towards the roof. I have attempted to change the language in the last sentence to address the committee concern.

Final Action: AS AM AMPC_____ D

RB221-07/08

AG101.2 (New), AG101.2.1 (New), AG101.2.2 (New)

Proposed Change as Submitted:

Proponent: Rebecca C. Quinn, RC Quinn Consulting, Inc., representing the US Department of Homeland Security, Federal Emergency Management Agency

Add new text as follows:

AG101.2 Pools in flood hazard areas. Pools that are located in flood hazard areas established by Table R301.2(1), including above-ground pools, on-ground pools, and in-ground pools that involve placement of fill, shall comply with Sections AG101.2.1 or AG101.2.2.

Exception: Pools located in riverine flood hazard areas which are outside of designated floodways.

AG101.2.1 Pools located in designated floodways. Where pools are located in designated floodways, documentation shall be submitted to the building official, which demonstrates that the construction of the pool will not increase the design flood elevation at any point within the jurisdiction.

AG101.2.2 Pools located where floodways have not been designated. Where pools are located where design flood elevations are specified but floodways have not been designated, documentation shall be submitted to the building official, which demonstrates that the cumulative effect of the proposed pool, when combined with all other existing and anticipated flood hazard area encroachment, will not increase the design flood elevation more than 1 foot (305 mm) at any point within the jurisdiction.

Reason: The purpose of this code change proposal is to address installation of swimming pools in or on the lot of a one- or two-family dwelling if the location of the proposed swimming pool is in the floodway of a flood hazard area, regardless of whether the floodway has been designated. Floodways are portions of riverine floodplains where encroachments, such as above-ground and on-ground pools or fill that may be placed around pools, may block the flow of floodwater and increase flood levels and flood risks on adjacent properties. Similar language regarding floodway encroachments is found at R324.1.3.2. This code change does not alter the scope of Appendix G.

Cost Impact: The code change proposal will not increase the cost of construction (more than 20,000 local jurisdictions already participate in the NFIP).

Committee Action:

Disapproved

Committee Reason: This proposal is unclear as to the floodway requirements and is inappropriate. Pools can be built such that the pool would not block the floodwater.

Assembly Action:

None

Individual Consideration Agenda

This item is on the agenda for individual consideration because a public comment was submitted.

Public Comment:

Rebecca C. Quinn, CFM, RCQuinn Consulting, Inc., representing the Department of Homeland Security/Federal Emergency Management Agency, requests Approval as Modified by this Public Comment.

Modify proposal as follows:

AG101.2.2 Pools located where floodways have not been designated. Where pools are located where design flood elevations are specified but floodways have not been designated, ~~the applicant shall provide a floodway analysis that demonstrates that the proposed pool documentation shall be submitted to the building official, which demonstrates that the cumulative effect of the proposed pool, when combined with all other existing and anticipated flood hazard area encroachment,~~ will not increase the design flood elevation more than 1 foot (305 mm) at any point within the jurisdiction.

(Portions of proposal not shown remain unchanged)

Commenter's Reason: It is accurate that pools can be built to avoid blocking floodwater, and the exception in AG101.2 allows pools to be installed outside of designated floodways without further consideration of impacts because such impacts have already been accounted for in the floodway analyses. However a small percentage of floodplains where FEMA has specified Base Flood Elevations do not have designated floodways.

Pools, especially above-ground pools and pools that involve fill, can block floodwater and cause waters to rise higher if they are placed in areas with effective flow (effective flow areas the areas that pass the greatest volumes of water, typically with higher velocities). The requirement to consider the impacts of development on flood heights where floodways have not been designated is consistent with the National Flood Insurance Program, the IRC R324.1.3.2, and the IBC.

This proposal as modified by this public comment replaces the phrase considered to be vague with a statement that a floodway analysis is required to determine impacts. Floodway analyses have been performed for decades. Commercial software packages for these analyses are readily available and FEMA provides software and technical guidance at www.fema.gov/plan/prevent/fhm/frm_soft.shtm#1.

The scoping statement of Appendix G, AG101.1, establishes which pools are required to comply with the provisions of the appendix. This code change does not alter which pools are regulated and which are unregulated.

Final Action: AS AM AMPC____ D

RB222-07/08

AG103.3 (New), AG108.1 (New)

Proposed Change as Submitted:

Proponent: Rebecca C. Quinn, RC Quinn Consulting, Inc., representing the US Department of Homeland Security, Federal Emergency Management Agency

Add new text as follows:

AG103.3 Pools in flood hazard areas. In flood hazard areas established by Table R301.2(1), pools in coastal high hazard areas shall be designed and constructed in conformance with ASCE 24.

Add standard to Section AG108 as follows:

ASCE
24-05 Flood Resistant Design and Construction

Reason: The purpose of this code change proposal is to address installation of swimming pools in or on the lot of a one- or two-family dwelling if the location of the proposed swimming pool is in a coastal high hazard areas (V Zone). Coastal high hazard areas are areas where wave heights are predicted to exceed 3 feet during the base flood. Breaking waves impart dynamic loads on structures, including above-ground pools and in-ground pools in soils that are subject to scour and erosion. ASCE 24 specifies that pools are to be designed to withstand flood-related loads and load combinations. If pools are structurally connected to buildings, the pools are to be designed to function as a continuation of the building (see R324.3.3). The regulations of the National Flood Insurance Program require that all development be designed and adequately anchored to prevent flotation, collapse, or lateral movement resulting from hydrodynamic and hydrostatic loads, including the effects of buoyancy (44 C.F.R. 60.3(a)(3)(i)). This code change does not alter the scope of Appendix G.

Cost Impact: The code change proposal will not increase the cost of construction (more than 20,000 local jurisdictions already participate in the NFIP).

Analysis: Review of proposed new standard ASCE 24-05 indicated that, in the opinion of ICC Staff, the standard did comply with ICC standards criteria.

Committee Action: **Disapproved**

Committee Reason: This proposal does not differentiate between a regulated and unregulated pool. All pools would have to comply with ASCE 24, including the portable pools.

Assembly Action: **None**

Individual Consideration Agenda

This item is on the agenda for individual consideration because a public comment was submitted.

Public Comment:

Rebecca C. Quinn, CFM, RCQuinn Consulting, Inc., representing the Department of Homeland Security/Federal Emergency Management Agency, requests Approval as Submitted.

Commenter's Reason: The scoping statement of Appendix G, AG101.1, differentiates between those pools subject to the requirements of Appendix G and those that are not. Therefore, it is not necessary for every provision in the Appendix to distinguish between those pools that are regulated and those that are not regulated by Appendix G. This code change does not require all pools coastal high hazard areas (V Zones) to comply with ASCE 24; it applies only to those pools that are subject to the requirements of the Appendix.

Coastal high hazard areas (V Zones) are areas where wave heights are predicted to exceed 3 feet during the base flood. Breaking waves impart dynamic loads on structures, including above-ground pools and in-ground pools in soils that are subject to scour and erosion. ASCE 24 specifies that pools are to be designed to withstand flood-related loads and load combinations. If pools are structurally connected to buildings, the existing text at R324.3.3 requires the pools to be designed to function as a continuation of the building. For dwellings in V Zones, note that in the 2007 cycle the IRC was modified to permit use of ASCE 24 as an alternative to the V Zone requirements of R324.3.

Final Action: AS AM AMPC____ D

RB227-07/08, Part I

AG 106.1, AG106.2, AG106.3, AG106.4, AG106.4.1, AG106.4.2, AG106.4.3, AG106.4.4, AG106.4.5, AG106.5, AG106.6, AG 108;

Proposed Change as Submitted:

Proponent: Lorraine Ross, Intech Consulting, Inc., representing the Association of Pool and Spa Professionals

PART I – IRC

1. Delete and substitute as follows:

~~**AG106.1 General.** Suction outlets shall be designed to produce circulation throughout the pool or spa. Single outlet systems, such as automatic vacuum cleaner systems, or multiple suction outlets, whether isolated by valves or otherwise, shall be protected against user entrapment.~~

AG106.1 Suction entrapment avoidance. Pools, spas, hot tubs, catch basins and other similar bather accessible bodies of water associated with swimming pool construction shall be designed to produce circulation throughout the body of water and provide means to protect against user suction entrapment in accordance with ANSI/APSP 7.

2. Delete without substitution:

~~**AG106.2 Suction fittings.** Pool and spa suction outlets shall have a cover that conforms to ANSI/ASME A112.19.8M, or an 18 inch x 23 inch (457mm by 584 mm) drain grate or larger, or an approved channel drain system.~~

~~**Exception:** Surface skimmers~~

~~**AG106.3 Atmospheric vacuum relief system required.** Pool and spa single or multiple outlet circulation systems shall be equipped with atmospheric vacuum relief should grate covers located therein become missing or broken. This vacuum relief system shall include at least one approved or engineered method of the type specified herein, as follows:~~

- ~~1. Safety vacuum release system conforming to ASME A112.19.17; or~~
- ~~2. An approved gravity drainage system.~~

~~**AG106.4 Dual drain separation.** Single or multiple pump circulation systems shall be provided with a minimum of two suction outlets of the approved type. A minimum horizontal or vertical distance of 3 feet (914 mm) shall separate the outlets. These suction outlets shall be piped so that water is drawn through them simultaneously through a vacuum-relief-protected line to the pump or pumps.~~

~~**AG106.5 Pool cleaner fittings.** Where provided, vacuum or pressure cleaner fitting(s) shall be located in an accessible position(s) at least 6 inches (152 mm) and not more than 12 inches (305 mm) below the minimum operational water level or as an attachment to the skimmer(s).~~

3. Add standard in Section AG108 as follows:

ANSI/APSP-7-06 Standard for Suction Entrapment Avoidance in Swimming Pools, Wading Pools, Spas, Hot Tubs, and Catch Basins

Reason: This proposal adds a new standard, ANSI/APSP 7 Standard for Suction Entrapment Avoidance in Swimming Pools, Wading Pools, Spas, Hot Tubs, and Catch Basins into IRC Section AG 106. It also deletes Sections AG 106.2 through AG 106.6 because all of these requirements have been incorporated into ANSI/APSP 7.

The current code language was an early response to body entrapment only. New information and technology has contributed to this new ANSI/APSP consensus standard and addresses all forms of entrapment, including the underlying causes of entrapment.

Although rare, entrapment of bathers at suction outlets in pools and spas has gained considerable attention over the last decade, resulting in voluntary standards, building codes, and proposed national legislation to prevent these tragic accidents.

A survey of the Epidemiological Reports on Suction Entrapment collected by the U.S. Consumer Product Safety Commission by the Association of Pool and Spa Professionals (APSP) Technical Committee yielded 5 distinct modes of Entrapment:

Entrapment Type	Percentage of Incidents
Hair Entrapment - Hair becomes knotted or snagged in an outlet cover	33%
Limb Entrapment – A limb sucked or inserted into an opening of a circulation outlet with a broken or missing cover resulting in a mechanical bind or swelling	28%
Body Entrapment – Suction applied to a large portion of the body or limbs resulting in an entrapment	33%
Evisceration/Disembowelment – suction applied directly to the intestines by a circulation outlet with a broken or missing cover.	3%
Mechanical Entrapment - Potential for jewelry, swimsuit, hair decorations, finger, toe, or knuckle to be mechanically caught in an opening of a suction outlet or cover.	Included in limb

Early actions to address entrapment were aimed at *body* entrapment by attempting to control the suction pressure at the drain itself.

Unfortunately, these devices do not protect against the major forms of entrapment: hair or evisceration. **Additionally, if the pool circulation pump is off - meaning no suction at the outlet - a child can still get a limb trapped if there is a broken or missing cover.**

Suction is only one factor to control in entrapment avoidance.

In order to address avoidance of all forms of entrapment, a comprehensive study of the causes of all types of entrapment was undertaken. It is now known that there are three basic underlying physical phenomena that govern all 5 modes of entrapment:

- Suction (or delta pressure)
- Water flow rate through the outlet or cover
- Mechanical binding

The Technical Committee of the Association of Pool and Spa Professionals (APSP) examined various means to prevent these types of entrapments recognizing the diverse nature of pool construction. Using this knowledge, a new national consensus standard was developed in accordance with the American National Standards Institute (ANSI) process. ANSI/APSP 7 *Standard for Suction Entrapment Avoidance in Swimming Pools, Wading Pools, Spas, Hot tubs, and Catch Basins (ANSI/APSP 7)* is based upon sound engineering principles, research, and field experience, that, when applied properly, provides the most comprehensive approach to protect bathers against all modes of entrapment. The ANSI standard approval process itself ensured that a wide variety of stakeholders were involved in the development of this standard, including building code officials, governmental health and pool industry experts.

The ANSI/APSP 7 standard applies to both commercial and residential pools, for flow rates from a few gallons per minute to thousands of gallons per minute. Although it includes the use of devices or systems that prevent suction, it also expands the lists of options for the pool contractor, while maintaining necessary protective principles.

ANSI/APSP-7 contains design performance criteria including components, devices and related technology installed to protect against entrapment. Analysis of past entrapments along with extensive testing shows:

- An outlet cover that complies with ASME/ANSI A112.19.8 will protect against limb, evisceration and mechanical entrapment

If the cover is missing or broken, there is no single device or system that can protect against entrapment. **For example, if the pool circulation pump is off - meaning no suction at the outlet - a child can still get a limb mechanically trapped,**

Therefore, ANSI/APSP 7 contains a warning to shut down the pool.

Unlike suction release devices that must be tested monthly, a pool owner can easily see if the cover is broken or missing. Having a SVRS with a missing or broken cover does not protect against limb, hair or mechanical entrapment and may give a pool owner a false sense of security regarding entrapment prevention.

- The maximum water flow rate in ANSI/APSP-7 is based on 6 fps and when combined with the required outlet cover provides protection against hair, limb, evisceration and mechanical entrapment.

Testing shows that water flow has a significant impact on entrapment avoidance.

- When used with a proper outlet cover and maximum water flow rate, options to address body entrapment in ANSI/APSP-7 include:
 - Dual Outlets at least 36" apart, measured center to center
 - Three or more outlets
 - Single Unblockable
 - Swim Jet
 - Alternative Suction System
 - Gravity Flow Systems
 - Outlet pumps in Series plus
 - SVRS, or
 - Vent, or
 - Additional Suction

The ability of dual drains to prevent body entrapment was recently demonstrated by a series of tests conducted by the APSP Technical Committee. Results showed that even with one drain blocked and a missing cover on the other, the low water flow rate mandated by ANSI/APSP - 7 prevented the necessary suction to hold down the 15 lb buoyant block used as a "pass" criteria when testing SVRS.

This test series illustrates the importance of water flow at the outlet when developing entrapment avoidance measures.

ANSI/APSP-7 utilizes the most comprehensive approach to outlet entrapment because it considers all underlying causes: suction, water flow and mechanical – while recognizing the diverse nature of pool and spa design. It covers all 5 forms of entrapment.

Tests conducted on dual outlets configured as described in ANSI/APSP-7 demonstrate:

- The size of the outlets and piping do have an effect on safe installation
- Water velocity of 6 fps (ANSI/APSP-7 maximum) *passed* an analogous ASME/ASTM SVRS test protocol,
- The combination of maximum water flow rates and dual outlets prevent body entrapment (with no SVRS), even if one outlet is blocked.
- Dual outlets, when installed according to ANSI/APSP-7, pass the same test criteria as the SVRS in both ASME/ANSI A112.19.17-2002 and ASTM F2387-2003, reacting faster than the 3 seconds response time and work properly in combination with skimmers.

Using submerged piping as is found in pools and spas, tests conducted on SVRS systems and both the ASME/ASTM SVRS standards demonstrate:

- Not all SVRS tested to the ASME/ASTM SVRS Standards will reliably "trip" when combined with dual outlets and/or skimmers – Those that fail seem to interpret residual flow from the second outlet as a priming pump.
- Not all SVRS tested to the ASME/SVRS Standards "trip" with partial outlet blockage.
- Water dynamics, in particular water hammer can facilitate release. Once the block is forced off the cover by these spikes in pressure, it floats to the surface. Neutrally buoyant blocks have been documented to "hammer" on and off open pipes for several seconds.
- Water dynamics continue for several seconds. The longest on an SVRS test lasted 2.72 seconds, which may call into question the 3 second limit.

Tests conducted on a U-Tube Vent on a single 18 x 18 suction outlet demonstrates:

- A single 18 x 18 drain grate can be successfully vented operating at 420 gpm with a 1 inch PVC vent pipe.
- Release is very fast – shortest release was 2.5 seconds
- While it was difficult to completely block the drain using a Human test subject, it was possible to do so sufficiently to trip the vent. The actual suction sensation of this experience was far less than what is experienced when an 8 inch sump is blocked.

ANSI/APSP -7 is the appropriate national consensus standard that is recommended for adoption in building codes. It has taken into account the initial steps taken in the building codes for specific devices and has expanded entrapment protection to include all 5 forms of entrapment by controlling all 3 underlying entrapment causes. In short, pool and spas designed and installed in accordance with ANSI/APSP – 7 are safer than those that rely upon a single device alone.

The technical committee of APSP is committed to continuing the effort to seek new understanding and knowledge regarding entrapment avoidance. Education of building code officials, legislators, pool designers and contractors and pool owners will always be a major activity of the APSP.

Cost Impact: The code change proposal will not increase the cost of construction.

PART I – IRC

Committee Action:

Disapproved

Committee Reason: This is a critical safety issue. The organizations need to work together to bring back a proposal that gives us better guidance. Section AG106.1 is poorly written. It is not known what is meant by "similar bather accessible bodies of water associated with swimming pools construction". Section AG106.1 is not the language directly out of the standard. This could be interpreted to apply to a drainage pond or goldfish pond in the yard. Also, this section will require all pools to have a circulation system and there are some pools that do not require this.

Assembly Action:

None

Individual Consideration Agenda

This item is on the agenda for individual consideration because public comments were submitted.

Public Comment 1:

Lorraine Ross, Intech Consulting inc., representing the Association of Pool and Spa Professionals, requests Approval as Modified by this Public Comment.

Modify proposal as follows:

**SECTION AG102
DEFINITIONS**

UNBLOCKABLE DRAIN. A drain of any size and shape that a human body cannot sufficiently block to create a suction entrapment hazard.

AG106.1 Suction entrapment avoidance. Pools, spas, hot tubs, catch basins and other similar bather accessible bodies of water associated with swimming pool construction shall be designed to produce circulation throughout the body of water and provide means to protect against user suction entrapment in accordance with ANSI/APSP 7.

General. Suction outlets shall be designed and installed in accordance with one of the following:

1. ANSI/APSP-7, or
2. All of the provisions of Section AG106.2 through Section AG106.5.

Add new section as follows:

AG106.2 Drain Configuration. Pools and spas shall be designed and installed with one of the following:

1. More than one suction outlet (drain), with a minimum horizontal or vertical distance of 3 ft (914 mm) between outlets. Maximum water velocity in suction branch piping shall be limited to 3 feet per second or a maximum of 6 feet per second (fps) (1.829 mps) if one of a pair of suction outlets is blocked
2. One or more unblockable drains, or
3. No main drain

AG106.3 Suction fittings. Pool and spa suction outlets shall have a cover that conforms to ANSI/ASME A112.19.8.

AG106.3.1 All suction outlet covers/grates shall have a permanently marked flow rating tested to prevent hair entrapment.

AG106.3.2 The marked flow rating provided on the suction outlet cover shall exceed the flow rate of the circulation system it is protecting.

AG106.4 Atmospheric vacuum relief system required. All pools and spas that have a single drain other than an unblockable drain shall be equipped with one or more of the following:

1. Safety vacuum release system which ceases operation of the pump, reverses the circulation flow, or otherwise provides a vacuum release at a suction outlet when a blockage is detected, that has been listed and labeled to conform to ANSI/ASME A112.19.17; or
2. An approved gravity drainage system that utilizes a collector tank, or
3. A suction-limiting vent system with a tamper resistant atmospheric opening, or
4. An automatic pump shut-off system, or
5. A drain disablement system.

AG106.5 Pool cleaner fittings. Where provided vacuum or pressure cleaner fitting(s) shall be designed to protect against limb entrapment. Vacuum cleaner fitting(s) shall include a self-closing cover that requires the use of a tool to open. Cleaner fitting(s) shall be located in an accessible position(s) at least 6 inches (152 mm) and not greater than 12 inches (305 mm) below the minimum operational water level.

Exception: Vacuum cleaner fitting(s) when used as an attachment to the skimmer(s).

Revise standard in Section AG108 as follows:

ASME/ANSI

A112.19.8M-1987(R1996)-2007 Suction Fittings for Use in Swimming Pools, Wading Pools, Spas, Hot Tubs and Whirlpool Bathing Appliances

Commenter's Reason: Current 2006 IRC entrapment avoidance language is in direct conflict with The Virginia Graeme Baker Federal Pool and Spa Safety Act, (Act) adopted in December 2007. The Act preempts sections of the IRC, and any code or state law that adopts the 2006 IRC after December 20, 2008 will be in violation of this Act. APSP realizes that this code development cycle will result in the 2009 IBC. So we are working diligently in those states where 2006 adoption has taken place or are contemplating adoption of the 2006 IBC to make necessary amendments to the entrapment avoidance section of the code.

APSP proposes this Public Comment for RB-227 Part I (IRC) to follow the intent of the Federal Act in its findings to increase pool safety by recognizing that there have been great strides in technology and pool and spa design regarding entrapment avoidance.

With respect to entrapment avoidance, the provisions in the new law are consistent with *ANSI/APSP-7 American National Standard for Suction Entrapment Avoidance (ANSI/APSP-7)*. This standard provides that all swimming pools and spas are to use proper anti-entrapment drain covers and circulation and drainage systems. The new standard will eliminate all future risk of all five forms of entrapment in pools and spas designed and installed in accordance with ANSI/APSP-7.

Some of the areas of conflict between the 2006 IRC and the Federal Act:

- As of December 20, 2008, Section 1404 (b) of the Federal Pool and Spa Safety Act expressly prohibits the manufacture sale or introduction into commerce of any drain cover that does not comply with ASME/ANSI A112.19.8 2007. This provision is defined as a "Consumer Product Safety Rule," meaning that the issue has been pre-empted. Hence, under the Consumer Product Safety Act, state and local governments may not establish or continue in effect any standard or regulation designed to deal with this same risk of injury unless said state or local requirements are identical the federal standard. 15 U.S.C. 2075(a).

- The 2006 IRC Section AG108 currently refers to the prior and now superseded 1987 (reaffirmed 1996) edition of the ASME A112.19.8 standard. This modification, which adopts the 2007 version of the standard corrects this conflict between the 2006 IBC and the Federal Act. There are substantial differences between this earlier edition and the 2007 version which is cited in the Act. For example, the newer standard includes enhanced resistance to UV rays, enhanced fastening requirements, resistance to hair entanglement and a new body block test that requires each drain to prevent body entrapment even when installed as a single, blockable drain.
- Section AG 106.2 of the IRC requires ASME 19.8 complaint covers, **or** a grate 12 x 12 **or** larger **or** a channel drain. Section 1404(c)(1) of the Act requires that all outlets/drains in all public pools be protected with ASME A112.19.8 - 2007 covers, regardless of size or shape. .
- Section 1406 of the Act calls for states to allow residential pools that have
 - (I) more than one drain
 - (II) 1 or more unblockable drains, or
 - (III) no main drain)
 Section AG106.1 of the IRC states "Suction outlets shall be designed to produce circulation throughout the pool or spa," and code officials have at times interpreted this provision to mean that a pool or spa may not be built without a main drain. This is in direct conflict with the intent of Congress, which is to allow states to permit pools without drains. Elimination of drains is the most effective way to eliminate entrapment injuries.
ANSI/APSP-7 (section 5.2) expressly allows for pools without suction outlets.
- 1406(d)(1) of the Act calls for states to require one of a series of options on residential pools "except for pools constructed without a single main drain." This is consistent with ANSI/APSP-7, which recognizes that SVRS and other shut off devices are only intended to work and are tested to work on pools or spas that have a single source of suction, not pools or spas with multiple drains. The Act also allows for eight backup options including any device which complies with either SVRS standard ASME or ASTM. However, the 2006 IRC section excludes five of these options, ignores one of the recognized SVRS standards cited in the Act and also requires "a backup for another backup" when multiple outlets are present –a clear conflict with the Federal Act. This IRC provision is also not consistent with the Act.

COMPARISON OF FEDERAL POOL AND SPA SAFETY ACT 2007*, ANSI/APSP-7 AND 2006 IRC CODE

Federal Pool & Spa Safety Act of 2007 *	ANSI/APSP-7 (See Note 1)	2006 ICC International Residential Codes
1404 (b) FEDERAL ACT (See Note 2) Requires that all drain (suction outlet) covers be tested and certified to ASME/ANSI A112.19.8-2007	Yes Section 4.5	No Section AG106.2 Exempts drains 18" x 23" or larger Exempts channel drains Permits grates 18" x 23" or larger
1406(a)(1)(A)(iv) <u>GRANT PROGRAM</u> Requires such covers to comply with "any successor standard" or version of ASME/ANSI A112.19.8	Yes Section 4.5	No Section AG108 Standards lists ANSI/ASME A112.19.8M-1987 (R1996) Suction Fittings for Use in Swimming Pools, Wading Pools, Spas, Hot Tubs and Whirlpool Bathing Appliances
1406(d)(1)(A-F) <u>GRANT PROGRAM</u> Existing pools with single drain that is not unblockable to have added protection	Yes Section 6.3	Yes Section AG106.3
1406(d)(1)(A-F) <u>GRANT PROGRAM</u> Allows all options recognized in ASME/ANSI A112.19.17 to protect single drain installations in residential pools and spas	Yes Section 7	No Section AG106.3 Prescriptive language requires "atmospheric vacuum relief" eliminating reversing circulation flow inconsistent with ASME/ANSI A112.19.17 Section 1.4 <i>Safety Vacuum Release System</i>
1406(d)(1)(A-F) <u>GRANT PROGRAM</u> Allows all devices that comply with ASTM F2387 to protect single drain installations in residential pools and spas	Yes Section 7.1	No Section AG106.3 Sub 1. Section AG108 Standards: ASTM F2387 not included
1406(d)(1)(A-F) <u>GRANT PROGRAM</u> Recognizes that SVRS or other devices are not required on pools or spas with multiple drains or an unblockable drain in residential pools	Yes Section 5.5.2	No Section AG3109.5.2

1. ANSI/APSP-7 2006 Standard for Suction Entrapment Avoidance in Swimming Pools, wading Pools, Spas, hot Tubs and Catch Basins.
2. Federal Act refers to section 1404, which creates a Federal Swimming Pool and Spa Drain Cover Standard, and requires that public pools be equipped with certain devices.

* The Federal Pool and Spa safety Act also known as the Virginia Graeme Baker Pool & Spa Safety Act

Adopting ANSI/APSP-7 into the IRC easily satisfies the Federal Act mandates and requirements for the optional grant program for states in regulating residential pools and spas.

ANSI/APSP-7 was reviewed and found to be in compliance with ICC policy regarding consensus standards by the ICC Staff prior to the Code Development Hearings in Palm Springs. The Committee recommended that APSP re-examine the "charging language" regarding the reference to ANSI/APSP-7. This has been accomplished in this modification.

Additionally, this modification takes an alternate step for the IRC to comply with the requirements of the Federal Pool and Spa Safety Act. It provides the use ANSI/APSP-7, as is, since it complies with the Federal Act. But it also corrects those sections of the current IRC that are in direct conflict with the Federal Act. This is provided for those who may need more information. If either choice is made, the 2009 provisions for entrapment avoidance will comply with the Federal Act.

Bibliography:

Title XIV Federal Pool and Spa Safety Act: Posted by the Consumer Product Safety Commission: <http://www.cpsc.gov/pssa.pdf>

"*Entrapment Prevention in Pools and Spas*" by Shajee Siddiqui, Published in the January-February 2008 issue of *Building Safety Journal*, copyright International Code Council, and is reprinted with permission:
http://www.apsp.org/clientresources/documents/Siddiqui_EntrapmentPools.Spas_reprint.pdf

"*ASTM Swimming Pool Safety Standard in New Law to Prevent Drowning Accidents*" by Kevin Cummins, ASTM website:
http://www.astm.org/SNEWS/MA_2008/outreach_ma08.html

Public Comment 2:

Lorraine Ross, Intech Consulting Inc., representing the Association of Pool and Spa Professionals, requests Approval as Modified by this Public Comment.

Modify proposal as follows:

~~**AG106.1 Suction entrapment avoidance.** Pools, spas, hot tubs, catch basins and other similar bather accessible bodies of water associated with swimming pool construction shall be designed to produce circulation throughout the body of water and provide means to protect against user suction entrapment in accordance with ANSI/APSP-7.~~ **General.** Suction outlets shall be designed and installed in accordance with ANSI/APSP-7.

Revise standard in AG108 as follows:

ASME/ANSI

A112.19.8M-1987(R1996) 8-2007 Suction Fittings for Use in Swimming Pools, Wading Pools, Spas, Hot Tubs and Whirlpool Bathing Appliances

Commenter's Reason: Current 2006 IRC entrapment avoidance language is in direct conflict with The Virginia Graeme Baker Federal Pool and Spa Safety Act, (Act) adopted in December 2007. The Act preempts sections of the IRC, and any code or state law that adopts the 2006 IRC after December 20, 2008 will be in violation of this Act. APSP realizes that this code development cycle will result in the 2009 IBC. So we are working diligently in those states where 2006 adoption has taken place or are contemplating adoption of the 2006 IBC to make necessary amendments to the entrapment avoidance section of the code.

APSP proposes this Public Comment for RB-227 Part I (IRC) to follow the intent of the Federal Act in its findings to increase pool safety by recognizing that there have been great strides in technology and pool and spa design regarding entrapment avoidance.

With respect to entrapment avoidance, the provisions in the new law are consistent with *ANSI/APSP-7 American National Standard for Suction Entrapment Avoidance (ANSI/APSP-7)*. This standard provides that all swimming pools and spas are to use proper anti-entrapment drain covers and circulation and drainage systems. The new standard will eliminate all future risk of all five forms of entrapment in pools and spas designed and installed in accordance with ANSI/APSP-7.

Some of the areas of conflict between the 2006 IRC and the Federal Act:

- As of December 20, 2008, Section 1404 (b) of the Federal Pool and Spa Safety Act expressly prohibits the manufacture sale or introduction into commerce of any drain cover that does not comply with ASME/ANSI A112.19.8 2007. This provision is defined as a "Consumer Product Safety Rule," meaning that the issue has been pre-empted. Hence, under the Consumer Product Safety Act, state and local governments may not establish or continue in effect any standard or regulation designed to deal with this same risk of injury unless said state or local requirements are identical the federal standard. 15 U.S.C. 2075(a).
- The 2006 IRC Section AG108 currently refers to the prior and now superseded 1987 (reaffirmed 1996) edition of the ASME A112.19.8 standard. This modification, which adopts the 2007 version of the standard corrects this conflict between the 2006 IBC and the Federal Act. There are substantial differences between this earlier edition and the 2007 version which is cited in the Act. For example, the newer standard includes enhanced resistance to UV rays, enhanced fastening requirements, resistance to hair entanglement and a new body block test that requires each drain to prevent body entrapment even when installed as a single, blockable drain.
- Section AG 106.2 of the IRC requires ASME 19.8 complaint covers, **or** a grate 12 x 12 **or** larger **or** a channel drain. Section 1404(c)(1) of the Act requires that all outlets/drains in all public pools be protected with ASME A112.19.8 - 2007 covers, regardless of size or shape. .
- Section 1406 of the Act calls for states to allow residential pools that have
 - (I) more than one drain
 - (II) 1 or more unblockable drains, or
 - (III) no main drain

Section AG106.1 of the IRC states "Suction outlets shall be designed to produce circulation throughout the pool or spa," and code officials have at times interpreted this provision to mean that a pool or spa may not be built without a main drain. This is in direct conflict with the intent of Congress, which is to allow states to permit pools without drains. Elimination of drains is the most effective way to eliminate entrapment injuries.

ANSI/APSP-7 (section 5.2) expressly allows for pools without suction outlets.

- 1406(d)(1) of the Act calls for states to require one of a series of options on residential pools "except for pools constructed without a single main drain." This is consistent with ANSI/APSP-7, which recognizes that SVRS and other shut off devices are only intended to work and are tested to work on pools or spas that have a single source of suction, not pools or spas with multiple drains. The Act also allows for eight backup options including any device which complies with either SVRS standard ASME or ASTM. However, the 2006 IRC section excludes five of these options, ignores one of the recognized SVRS standards cited in the Act and also requires "a backup for another backup" when multiple outlets are present – a clear conflict with the Federal Act. This IRC provision is also not consistent with the Act.

COMPARISON OF FEDERAL POOL AND SPA SAFETY ACT 2007*, ANSI/APSP-7 AND 2006 IRC CODE

Federal Pool & Spa Safety Act of 2007 *	ANSI/APSP-7 (See Note 1)	2006 ICC International Residential Codes
1404 (b) FEDERAL ACT (See Note 2) Requires that all drain (suction outlet) covers be tested and certified to ASME/ANSI A112.19.8-2007	Yes Section 4.5	No Section AG106.2 Exempts drains 18" x 23" or larger Exempts channel drains Permits grates 18" x 23" or larger
1406(a)(1)(A)(iv) <u>GRANT PROGRAM</u> Requires such covers to comply with "any successor standard" or version of ASME/ANSI A112.19.8	Yes Section 4.5	No Section AG108 Standards lists ANSI/ASME A112.19.8M-1987 (R1996) Suction Fittings for Use in Swimming Pools, Wading Pools, Spas, Hot Tubs and Whirlpool Bathing Appliances
1406(d)(1)(A-F) <u>GRANT PROGRAM</u> Existing pools with single drain that is not unblockable to have added protection	Yes Section 6.3	Yes Section AG106.3
1406(d)(1)(A-F) <u>GRANT PROGRAM</u> Allows all options recognized in ASME/ANSI A112.19.17 to protect single drain installations in residential pools and spas	Yes Section 7	No Section AG106.3 Prescriptive language requires "atmospheric vacuum relief" eliminating reversing circulation flow inconsistent with ASME/ANSI A112.19.17 Section 1.4 <i>Safety Vacuum Release System</i>
1406(d)(1)(A-F) <u>GRANT PROGRAM</u> Allows all devices that comply with ASTM F2387 to protect single drain installations in residential pools and spas	Yes Section 7.1	No Section AG106.3 Sub 1. Section AG108 Standards: ASTM F2387 not included
1406(d)(1)(A-F) <u>GRANT PROGRAM</u> Recognizes that SVRS or other devices are not required on pools or spas with multiple drains or an unblockable drain in residential pools	Yes Section 5.5.2	No Section AG3109.5.2

1. ANSI/APSP-7 2006 Standard for Suction Entrapment Avoidance in Swimming Pools, wading Pools, Spas, hot Tubs and Catch Basins.
2. Federal Act refers to section 1404, which creates a Federal Swimming Pool and Spa Drain Cover Standard, and requires that public pools be equipped with certain devices.

* The Federal Pool and Spa safety Act also known as the Virginia Graeme Baker Pool & Spa Safety Act

Adopting ANSI/APSP-7 into the IRC easily satisfies the Federal Act mandates and requirements for the optional grant program for states in regulating residential pools and spas.

ANSI/APSP-7 was reviewed and found to be in compliance with ICC policy regarding consensus standards by the ICC Staff prior to the Code Development Hearings in Palm Springs. The Committee recommended that APSP re-examine the "charging language" regarding the reference to ANSI/APSP-7. This has been accomplished in this modification.

APSP also realizes that this code development cycle will result in the 2009 IRC. So we are working diligently in those states where 2006 adoption has taken place or are contemplating adoption of the 2006 IBC to make necessary amendments to the entrapment avoidance section of the code.

Bibliography:

Title XIV Federal Pool and Spa Safety Act: Posted by the Consumer Product Safety Commission: <http://www.cpsc.gov/pssa.pdf>

"Entrapment Prevention in Pools and Spas" by Shajee Siddiqui, Published in the January-February 2008 issue of *Building Safety Journal*, copyright International Code Council, and is reprinted with permission:

http://www.apsp.org/clientresources/documents/Siddiqui_EntrapmentPools.Spas_reprint.pdf

Final Action: AS AM AMPC___ D

RB227-07/08, Part II

IBC 3109.5, 3109.5.1, 3109.5.2, 3109.5.3, 3109.5.4, Chapter 35

Proposed Change as Submitted:

Proponent: Lorraine Ross, Intech Consulting, Inc., representing the Association of Pool and Spa Professionals

PART II – IBC GENERAL

1. Delete and substitute as follows:

~~**3109.5 Entrapment avoidance.** Suction outlets shall be designed to produce circulation throughout the pool or spa. Single outlet systems, such as automatic vacuum cleaner systems, or other such multiple suction outlets whether isolated by valves or otherwise shall be protected against user entrapment.~~

~~**3109.5 Suction entrapment avoidance.** Pools, spas, hot tubs, catch basins and other similar bather accessible bodies of water associated with swimming pool construction shall be designed to produce circulation throughout the body of water and provide means to protect against user suction entrapment in accordance with ANSI/APSP 7.~~

2. Delete without substitution:

~~**3109.5.1 Suction fittings.** All pool and spa suction outlets shall be provided with a cover that conforms to ASME A112.19.8M, a 12 inch by 12 inch (305 mm by 305 mm) drain grate or larger, or an approved channel drain system.~~

~~**Exception:** Surface skimmers.~~

~~**3109.5.2 Atmospheric vacuum relief system required.** All pool and spa single or multiple outlet circulation systems shall be equipped with an atmospheric vacuum relief approved or engineered method of the type specified herein, as follows:~~

- ~~1. Safety vacuum release systems conforming to ASME A112.19.17; or~~
- ~~2. Approved gravity drainage system.~~

~~**3109.5.3 Dual drain separation.** Single or multiple pump circulation systems shall be provided with a minimum of two suction outlets of the approved type. A minimum horizontal or vertical distance of 3 feet (914 mm) shall separate such outlets. These suction outlets shall be piped so that water is drawn through them simultaneously through a vacuum relief protected line to the pump or pumps.~~

~~**3109.5.4 Pool cleaner fittings.** Where provided, vacuum or pressure cleaner fitting(s) shall be located in an accessible position(s) at least 6 inches (152 mm) and not greater than 12 inches (305 mm) below the minimum operational water level or as an attachment to the skimmer(s).~~

3. Add standard to Chapter 35 as follows:

ANSI/APSP-7-06 Standard for Suction Entrapment Avoidance in Swimming Pools, Wading Pools, Spas, Hot Tubs, and Catch Basins

Reason: This proposal adds a new standard, ANSI/APSP 7 Standard for Suction Entrapment Avoidance in Swimming Pools, Wading Pools, Spas, Hot Tubs, and Catch Basins into IBC Section 3109.5. It also deletes Sections 3109.5.1 through 3109.5.5 because all of these requirements have been incorporated into ANSI/APSP 7.

The current code language was an early response to body entrapment only. New information and technology has contributed to this new ANSI/APSP consensus standard and addresses all forms of entrapment, including the underlying causes of entrapment.

Although rare, entrapment of bathers at suction outlets in pools and spas has gained considerable attention over the last decade, resulting in voluntary standards, building codes, and proposed national legislation to prevent these tragic accidents.

A survey of the Epidemiological Reports on Suction Entrapment collected by the U.S. Consumer Product Safety Commission by the Association of Pool and Spa Professionals (APSP) Technical Committee yielded 5 distinct modes of Entrapment:

Entrapment Type	Percentage of Incidents
Hair Entrapment - Hair becomes knotted or snagged in an outlet cover	33%
Limb Entrapment – A limb sucked or inserted into an opening of a circulation outlet with a broken or missing cover resulting in a mechanical bind or swelling	28%
Body Entrapment – Suction applied to a large portion of the body or limbs resulting in an entrapment	33%
Evisceration/Disembowelment – suction applied directly to the intestines by a circulation outlet with a broken or missing cover.	3%
Mechanical Entrapment - Potential for jewelry, swimsuit, hair decorations, finger, toe, or knuckle to be mechanically caught in an opening of a suction outlet or cover.	Included in limb

Early actions to address entrapment were aimed at *body* entrapment by attempting to control the suction pressure at the drain itself. Unfortunately, these devices do not protect against the major forms of entrapment: hair or evisceration. **Additionally, if the pool circulation pump is off - meaning no suction at the outlet - a child can still get a limb trapped if there is a broken or missing cover.**

Suction is only one factor to control in entrapment avoidance.

In order to address avoidance of all forms of entrapment, a comprehensive study of the causes of all types of entrapment was undertaken. It is now known that there are three basic underlying physical phenomena that govern all 5 modes of entrapment:

- Suction (or delta pressure)
- Water flow rate through the outlet or cover
- Mechanical binding

The Technical Committee of the Association of Pool and Spa Professionals (APSP) examined various means to prevent these types of entrapments recognizing the diverse nature of pool construction. Using this knowledge, a new national consensus standard was developed in accordance with the American National Standards Institute (ANSI) process. *ANSI/APSP 7 Standard for Suction Entrapment Avoidance in Swimming Pools, Wading Pools, Spas, Hot tubs, and Catch Basins (ANSI/APSP 7)* is based upon sound engineering principles, research, and field experience, that, when applied properly, provides the most comprehensive approach to protect bathers against all modes of entrapment. The ANSI standard approval process itself ensured that a wide variety of stakeholders were involved in the development of this standard, including building code officials, governmental health and pool industry experts.

The ANSI/APSP 7 standard applies to both commercial and residential pools, for flow rates from a few gallons per minute to thousands of gallons per minute. Although it includes the use of devices or systems that prevent suction, it also expands the lists of options for the pool contractor, while maintaining necessary protective principles.

ANSI/APSP-7 contains design performance criteria including components, devices and related technology installed to protect against entrapment. Analysis of past entrapments along with extensive testing shows:

- An outlet cover that complies with ASME/ANSI A112.19.8 will protect against limb, evisceration and mechanical entrapment

If the cover is missing or broken, there is no single device or system that can protect against entrapment. **For example, if the pool circulation pump is off - meaning no suction at the outlet - a child can still get a limb mechanically trapped,**

Therefore, ANSI/APSP 7 contains a warning to shut down the pool.

Unlike suction release devices that must be tested monthly, a pool owner can easily see if the cover is broken or missing. Having a SVRS with a missing or broken cover does not protect against limb, hair or mechanical entrapment and may give a pool owner a false sense of security regarding entrapment prevention.

- The maximum water flow rate in ANSI/APSP-7 is based on 6 fps and when combined with the required outlet cover provides protection against hair, limb, evisceration and mechanical entrapment.

Testing shows that water flow has a significant impact on entrapment avoidance.

- When used with a proper outlet cover and maximum water flow rate, options to address body entrapment in ANSI/APSP-7 include:

- Dual Outlets at least 36" apart, measured center to center
- Three or more outlets
- Single Unblockable
- Swim Jet
- Alternative Suction System
- Gravity Flow Systems
- Outlet pumps in Series plus
 - SVRS, or
 - Vent, or
 - Additional Suction

The ability of dual drains to prevent body entrapment was recently demonstrated by a series of tests conducted by the APSP Technical Committee. Results showed that even with one drain blocked and a missing cover on the other, the low water flow rate mandated by ANSI/APSP -7 prevented the necessary suction to hold down the 15 lb buoyant block used as a "pass" criteria when testing SVRS.

This test series illustrates the importance of water flow at the outlet when developing entrapment avoidance measures.

ANSI/APSP-7 utilizes the most comprehensive approach to outlet entrapment because it considers all underlying causes: suction, water flow and mechanical – while recognizing the diverse nature of pool and spa design. It covers all 5 forms of entrapment.

Tests conducted on dual outlets configured as described in ANSI/APSP-7 demonstrate:

- The size of the outlets and piping do have an effect on safe installation
- Water velocity of 6 fps (ANSI/APSP-7 maximum) *passed* an analogous ASME/ASTM SVRS test protocol,
- The combination of maximum water flow rates and dual outlets prevent body entrapment (with no SVRS), even if one outlet is blocked.
- Dual outlets, when installed according to ANSI/APSP-7, pass the same test criteria as the SVRS in both ASME/ANSI A112.19.17-2002 and ASTM F2387-2003, reacting faster than the 3 seconds response time and work properly in combination with skimmers.

Using submerged piping as is found in pools and spas, tests conducted on SVRS systems and both the ASME/ASTM SVRS standards demonstrate:

- Not all SVRS tested to the ASME/ASTM SVRS Standards will reliably "trip" when combined with dual outlets and/or skimmers – Those that fail seem to interpret residual flow from the second outlet as a priming pump.
- Not all SVRS tested to the ASME/SVRS Standards "trip" with partial outlet blockage.
- Water dynamics, in particular water hammer can facilitate release. Once the block is forced off the cover by these spikes in pressure, it float to the surface. Neutrally buoyant blocks have been documented to "hammer" on and off open pipes for several seconds.
- Water dynamics continue for several seconds. The longest on an SVRS test lasted 2.72 seconds, which may call into question the 3 second limit.

Tests conducted on a U-Tube Vent on a single 18 x 18 suction outlet demonstrates:

- A single 18 x 18 drain grate can be successfully vented operating at 420 gpm with a 1 inch PVC vent pipe.
- Release is very fast – shortest release was 2.5 seconds
- While it was difficult to completely block the drain using a Human test subject, it was possible to do so sufficiently to trip the vent. The actual suction sensation of this experience was far less than what is experienced when an 8 inch sump is blocked.

ANSI/APSP -7 is the appropriate national consensus standard that is recommended for adoption in building codes. It has taken into account the initial steps taken in the building codes for specific devices and has expanded entrapment protection to include all 5 forms of entrapment by controlling all 3 underlying entrapment causes. In short, pool and spas designed and installed in accordance with ANSI/APSP – 7 are safer than those that rely upon a single device alone.

The technical committee of APSP is committed to continuing the effort to seek new understanding and knowledge regarding entrapment avoidance. Education of building code officials, legislators, pool designers and contractors and pool owners will always be a major activity of the APSP.

Cost Impact: This code change proposal will not increase the cost of construction

**PART II – IBC GENERAL
Committee Action:**

Disapproved

Committee Reason: Based upon proponents request.

Assembly Action:

None

Individual Consideration Agenda

This item is on the agenda for individual consideration because public comments were submitted.

Public Comment 1:

Lorraine Ross, Intech Consulting inc., representing the Association of Pool and Spa Professionals, requests Approval as Modified by this Public Comment.

Modify proposal as follows:

Add new definition to Section 3109.2 as follows:

UNBLOCKABLE DRAIN. A drain of any size and shape that a human body cannot sufficiently block to create a suction entrapment hazard.

Delete and substitute as follows:

~~**3109.5 Suction entrapment avoidance.** Pools, spas, hot tubs, catch basins and other similar bather accessible bodies of water associated with swimming pool construction shall be designed to produce circulation throughout the body of water and provide means to protect against user suction entrapment in accordance with ANSI/APSP 7.~~

3109.5 Entrapment avoidance. Suction outlets shall be designed and installed in accordance with one of the following:

1. NSI/APSP-7, or
2. II of the provisions of Section 3109.5.1 through Section 3109.5.4.

Add new text as follows:

3109.5.1 Drain Configuration. Pools and spas shall be designed and installed with one of the following:

1. ore than one suction outlet (drain), with a minimum horizontal or vertical distance of 3 ft (914 mm) between outlets. Maximum water velocity in suction branch piping shall be limited to 3 feet per second or a maximum of 6 feet per second (fps) (1.829 mps) if one of a pair of suction outlets is blocked
2. ne or more unblockable drains, or
3. o main drain

3109.5.2 Suction fittings. All pool and spa suction outlets shall be provided with a cover that has been tested and listed to conform to ANSI/ASME A112.19.8

3109.5.2.1 All suction outlet covers/grates shall have a permanently marked flow rating tested to prevent hair entrapment.

3109.5.2.2 The marked flow rating provided on the suction outlet cover shall exceed the flow rate of the circulation system it is protecting.

3109.5.3 Atmospheric vacuum relief system required. All pools and spas that have a single drain other than an unblockable drain shall be equipped with one or more of the following:

1. Safety vacuum release system which ceases operation of the pump, reverses the circulation flow, or otherwise provides a vacuum release at a suction outlet when a blockage is detected, that has been listed and labeled to conform to ANSI/ASME A112.19.17, or
2. n approved gravity drainage system that utilizes a collector tank, or –
3. suction-limiting vent system with a tamper resistant atmospheric opening, or
4. n automatic pump shut-off system, or
5. drain disablement system.

3109.5.4 Pool cleaner fittings. Where provided cleaner fitting(s) shall be designed to protect against limb entrapment. Vacuum cleaner fitting(s) shall include a self-closing cover that requires the use of a tool to open. Cleaner fitting(s) shall be located in an accessible position(s) at least 6 inches (152 mm) and not greater than 12 inches (305 mm) below the minimum operational water level.

Exception: Vacuum cleaner fitting(s) when used as an attachment to the skimmer(s).

Revise standard in Chapter 35 as follows:

ASME/ANSI

A112.19.8M-4987-2007 Suction Fittings for Use in Swimming Pools, Wading Pools, Spas, Hot Tubs and Whirlpool Bathing Appliances

Commenter's Reason: Current 2006 IBC entrapment avoidance language is in direct conflict with The Virginia Graeme Baker Federal Pool and Spa Safety Act, (Act) adopted in December 2007. The Act preempts sections of the IBC, and any code or state law that adopts the 2006 IBC after December 20, 2008 will be in violation of this Act. APSP realizes that this code development cycle will result in the 2009 IBC. So we are working diligently in those states where 2006 adoption has taken place or are contemplating adoption of the 2006 IBC to make necessary amendments to the entrapment avoidance section of the code.

Some of the areas of conflict between the 2006 IBC and the Federal Act:

- As of December 20, 2008, Section 1404 (b) of the Federal Pool and Spa Safety Act expressly prohibits the manufacture sale or introduction into commerce of any drain cover that does not comply with ASME/ANSI A112.19.8 - 2007. This provision is defined as a "Consumer Product Safety Rule," meaning that the issue has been pre-empted. Hence, under the Consumer Product Safety Act, state and local governments may not establish or continue in effect any standard or regulation designed to deal with this same risk of injury unless said state or local requirements are identical the federal standard. 15 U.S.C. 2075(a).
- The 2006 IBC currently refers to the prior and now superseded 1987 (reaffirmed 1996) edition of the ASME A112.19.8 standard. This modification, which adopts the 2007 version of the standard corrects this conflict between the 2006 IBC and the Federal Act. There are substantial differences between this earlier edition and the 2007 version which is cited in the Act. For example, the newer standard includes enhanced resistance to UV rays, enhanced fastening requirements, resistance to hair entanglement and a new body block test that requires each drain to prevent body entrapment even when installed as a single, blockable drain.
- Section 3109.5.1 of the 2006 IBC requires ASME 19.8 complaint covers, **or** a grate 12 x 12 **or** larger **or** a channel drain. Section 1404(c)(1) of the Act requires that all outlets/drains in all public pools be protected with ASME A112.19.8 - 2007 covers, regardless of size or shape.
- Section 1404 (c)(1)(A)(ii) of the Act requires one or more of a series of options on public pools and spas that have a "single drain other than an unblockable drain." This is consistent with ANSI/APSP-7, which recognizes that SVRS and other shut off devices are only intended to work and are tested to work on pools or spas that have a single source of suction, not pools or spas with multiple drains. The Act also allows for eight backup options including any device which complies with either SVRS standard ASME or ASTM. However, the 2006 IBC section 3109.5.2 excludes five of these options, ignores one of the recognized SVRS standards cited in the Act and also requires a backup for another backup when multiple outlets are present – a clear conflict with the Federal Act..

With respect to entrapment avoidance, the provisions in the new law are consistent with *ANSI/APSP-7 American National Standard for Suction Entrapment Avoidance (ANSI/APSP-7)*. This standard provides that all swimming pools and spas are to use proper anti-entrapment drain covers and circulation and drainage systems. The new standard will eliminate all future risk of all five forms of entrapment in pools and spas designed and installed in accordance with ANSI/APSP-7.

ANSI/APSP-7 was reviewed and found to be in compliance with ICC policy regarding consensus standards by the ICC Staff prior to the Code Development Hearings in Palm Springs. The Committee recommended that APSP re-examine the "charging language" regarding the reference to ANSI/APSP-7. This has been accomplished in this modification.

Additionally, this modification takes an alternate step for the IBC to comply with the requirements of the Federal Pool and Spa Safety Act. It provides the use ANSI/APSP-7, as is ,since it complies with the Federal Act. But it also corrects those sections of the current IBC that are in direct conflict with the Federal Act. This is provided for those who may need more information. If either choice is made, the 2009 provisions for entrapment avoidance will comply with the Federal Act.

COMPARISON OF FEDERAL POOL AND SPA SAFETY ACT 2007*, ANSI/APSP-7 AND 2006 IBC

Federal Pool & Spa Safety Act of 2007 *	ANSI/APSP-7 (See Note 1 below chart)	2006 International Building Codes
1404 (b) FEDERAL ACT (See Note 2 below chart) Requires that all drain (suction outlet) covers be tested and certified to ASME/ANSI A112.19.8-2007	Yes Section 4.5	No Section 3109.5.1 Exempts drains 12 x 12 or larger Exempts channel drains References
1404(b) FEDERAL ACT Requires future covers to comply with "any successor standard" or version of 19.8	Yes Section 4.5	No Chapter 35 References old edition: ASME/ANSI A112.19.8M -1987 (R1996) edition only
1404 (c)(1)(A)(i) FEDERAL ACT Requires ASME/ANSI certified covers on all drains regardless of size in public pools and spas	Yes Section 1.1 Section 4.5	No Section 3109.5.1 Exempts drains 12 x 12 or larger Exempts channel drains
1404 (c)(1)(A)(ii) FEDERAL ACT Public pools and spas with a single drain that is not unblockable to have added protection	Yes Section 1.1 Section 6.3 Note: single blockable drain prohibited in new construction	Incomplete Section 3109.5.2 references Suction Relief valves and gravity drains but does not list the other options in the Federal Act: <ul style="list-style-type: none"> ▪ A safety vacuum release system (SVRS) conforming to ASMT F2387, or ▪ A suction-limiting vent system with a tamper resistant atmospheric opening, or ▪ An automatic pump shut-off system, or ▪ A drain disablement system.
1404 (c)(1)(A)(ii) (I-VI) FEDERAL ACT Allows all options recognized in ASME/ANSI A112.19.17 to protect single drain installations in public pools and spas	Yes Section 7	No Section 3109.5.2 Prescriptive language requires "atmospheric vacuum relief" eliminating reversing circulation flow inconsistent with ASME Section 1.4 <i>Safety Vacuum Release System</i>
1404 (c)(1)(A)(ii) (I-VI) FEDERAL ACT Allows all devices that comply with ASTM F2387 to protect single drain installations in public pools and spas	Yes Section 7.1	No Section 3109.5.2 Sub 1. Chapter 35 does not currently include ASTM F2387
1404 (c)(1)(A)(ii) FEDERAL ACT Recognizes that Safety Vacuum release System (SVRS) or other devices are not required on public pools or spas with multiple drains or an unblockable drain	Yes Section 5.5.2	No Section 3109.5.2

1 ANSI/APSP-7 2006 Standard for Suction Entrapment Avoidance in Swimming Pools, wading Pools, Spas, hot Tubs and Catch Basins.

2 Federal Act refers to section 1404, which creates a Federal Swimming Pool and Spa Drain Cover Standard, and requires that public pools be equipped with certain devices.

* The Federal Pool and Spa safety Act also known as the Virginia Graeme Baker Pool & Spa Safety Act

Consistent with the new law, mandated changes to entrapment avoidance requirements are necessary and can most efficiently become enforced through the ICC Code development process. This will enable states to more easily adopt the Federal provisions by adopting the IBC. Otherwise, these entrapment avoidance provisions will have to be handled on a state and local level such as the case where the Florida Building Commission adopted the ANSI/APSP-7 Standard into the 2007 Florida Building Code.

Bibliography:

Title XIV Federal Pool and Spa Safety Act: Posted by the Consumer Product Safety Commission: <http://www.cpsc.gov/pssa.pdf>

"Entrapment Prevention in Pools and Spas" by Shajee Siddiqui, Published in the January-February 2008 issue of *Building Safety Journal*, copyright International Code Council, and is reprinted with permission:

http://www.apsp.org/clientresources/documents/Siddiqui_EntrapmentPools_Spas_reprint.pdf

Public Comment 2:

Lorraine Ross, Intech Consulting Inc., representing the Association of Pool and Spa Professionals, requests Approval as Modified by this Public Comment.

Modify proposal as follows:

~~**3109.5 Suction entrapment avoidance.** Pools, spas, hot tubs, catch basins and other similar bather accessible bodies of water associated with swimming pool construction shall be designed to produce circulation throughout the body of water and provide means to protect against user suction entrapment in accordance with ANSI/APSP-7.~~

3109.5 Entrapment avoidance. Suction outlets shall be designed and installed in accordance with ANSI/APSP-7.

Commenter's Reason: Current 2006 IBC entrapment avoidance language is in direct conflict with The Virginia Graeme Baker Federal Pool and Spa Safety Act, (Act) adopted in December 2007. The Act preempts sections of the IBC, and any code or state law that adopts the 2006 IBC after December 20, 2008 will be in violation of this Act. APSP realizes that this code development cycle will result in the 2009 IBC. So we are working diligently in those states where 2006 adoption has taken place or are contemplating adoption of the 2006 IBC to make necessary amendments to the entrapment avoidance section of the code. ICC has also been extremely helpful in educating its members through the ICC website, the ICC eNewsletter and the ICC *Building Safety Journal* articles.

Some of the areas of conflict between the 2006 IBC and the Federal Act:

- As of December 20, 2008, Section 1404 (b) of the Federal Pool and Spa Safety Act expressly prohibits the manufacture sale or introduction into commerce of any drain cover that does not comply with ASME/ANSI A112.19.8 - 2007. This provision is defined as a "Consumer Product Safety Rule," meaning that the issue has been pre-empted. Hence, under the Consumer Product Safety Act, state and local governments may not establish or continue in effect any standard or regulation designed to deal with this same risk of injury unless said state or local requirements are identical the federal standard. 15 U.S.C. 2075(a).
- The 2006 IBC currently refers to the prior and now superseded 1987 (reaffirmed 1996) edition of the ASME A112.19.8 standard. This modification, which adopts the 2007 version of the standard corrects this conflict between the 2006 IBC and the Federal Act. There are substantial differences between this earlier edition and the 2007 version which is cited in the Act. For example, the newer standard includes enhanced resistance to UV rays, enhanced fastening requirements, resistance to hair entanglement and a new body block test that requires each drain to prevent body entrapment even when installed as a single, blockable drain.
- Section 3109.5.1 of the 2006 IBC requires ASME 19.8 complaint covers, **or** a grate 12 x 12 **or** larger **or** a channel drain. Section 1404(c)(1) of the Act requires that all outlets/drains in all public pools be protected with ASME A112.19.8 - 2007 covers, regardless of size or shape.
- Section 1404 (c)(1)(A)(ii) of the Act requires one or more of a series of options on public pools and spas that have a "single drain other than an unblockable drain." This is consistent with ANSI/APSP-7, which recognizes that SVRS and other shut off devices are only intended to work and are tested to work on pools or spas that have a single source of suction, not pools or spas with multiple drains. The Act also allows eight backup options including any device which complies with either SVRS standard, ASME or ASTM. However, the 2006 IBC section 3109.5.2 excludes five of these options, ignores one of the recognized SVRS standards cited in the Act and also requires a backup for another backup when multiple outlets are present –a clear conflict with the Federal Act.

With respect to entrapment avoidance, the provisions in the new law are consistent with ANSI/APSP-7 *American National Standard for Suction Entrapment Avoidance (ANSI/APSP-7)*. This standard provides that all swimming pools and spas are to use proper anti-entrapment drain covers and circulation and drainage systems. The new standard will eliminate all future risk of all five forms of entrapment in pools and spas designed and installed in accordance with ANSI/APSP-7.

ANSI/APSP-7 was reviewed and found to be in compliance with ICC policy regarding consensus standards by the ICC Staff prior to the Code Development Hearings in Palm Springs. The Committee recommended that APSP re-examine the "charging language" regarding the reference to ANSI/APSP-7. This has been accomplished in this modification.

This chart illustrates the fact that adopting ANSI/APSP-7 into the IBC easily satisfies the Federal Act mandates:

COMPARISON OF FEDERAL POOL AND SPA SAFETY ACT 2007*, ANSI/APSP-7 AND 2006 IBC

Federal Pool & Spa Safety Act of 2007 *	ANSI/APSP-7 (See Note 1 below chart)	2006 International Building Codes
1404 (b) FEDERAL ACT (See Note 2 below chart) Requires that all drain (suction outlet) covers be tested and certified to ASME/ANSI A112.19.8-2007	Yes Section 4.5	No Section 3109.5.1 Exempts drains 12 x 12 or larger Exempts channel drains References
1404(b) FEDERAL ACT Requires future covers to comply with "any successor standard" or version of 19.8	Yes Section 4.5	No Chapter 35 References old edition: ASME/ANSI A112.19.8M -1987 (R1996) edition only
1404 (c)(1)(A)(i) FEDERAL ACT Requires ASME/ANSI certified covers on all drains regardless of size in public pools and spas	Yes Section 1.1 Section 4.5	No Section 3109.5.1 Exempts drains 12 x 12 or larger Exempts channel drains

<p align="center">1404 (c)(1)(A)(ii) FEDERAL ACT</p> <p>Public pools and spas with a single drain that is not unblockable to have added protection</p>	<p align="center">Yes Section 1.1 Section 6.3 Note: single blockable drain prohibited in new construction</p>	<p align="center">Incomplete</p> <p>Section 3109.5.2 references Suction Relief valves and gravity drains but does not list the other options in the Federal Act:</p> <ul style="list-style-type: none"> ▪ A safety vacuum release system (SVRS) conforming to ASMT F2387, or ▪ A suction-limiting vent system with a tamper resistant atmospheric opening, or ▪ An automatic pump shut-off system, or ▪ A drain disablement system.
<p align="center">1404 (c)(1)(A)(ii) (I-VI) FEDERAL ACT</p> <p>Allows all options recognized in ASME/ANSI A112.19.17 to protect single drain installations in public pools and spas</p>	<p align="center">Yes Section 7</p>	<p align="center">No Section 3109.5.2</p> <p>Prescriptive language requires "atmospheric vacuum relief" eliminating reversing circulation flow inconsistent with ASME Section 1.4 <i>Safety Vacuum Release System</i></p>
<p align="center">1404 (c)(1)(A)(ii) (I-VI) FEDERAL ACT</p> <p>Allows all devices that comply with ASTM F2387 to protect single drain installations in public pools and spas</p>	<p align="center">Yes Section 7.1</p>	<p align="center">No Section 3109.5.2 Sub 1.</p> <p>Chapter 35 does not currently include ASTM F2387</p>
<p align="center">1404 (c)(1)(A)(ii) FEDERAL ACT</p> <p>Recognizes that Safety Vacuum release System (SVRS) or other devices are not required on public pools or spas with multiple drains or an unblockable drain</p>	<p align="center">Yes Section 5.5.2</p>	<p align="center">No Section 3109.5.2</p>

1 ANSI/APSP-7 2006 Standard for Suction Entrapment Avoidance in Swimming Pools, wading Pools, Spas, hot Tubs and Catch Basins.

2 Federal Act refers to section 1404, which creates a Federal Swimming Pool and Spa Drain Cover Standard, and requires that public pools be equipped with certain devices.

* The Federal Pool and Spa safety Act also known as the Virginia Graeme Baker Pool & Spa Safety Act

Consistent with the new law, mandated changes to entrapment avoidance requirements are necessary and can most efficiently become enforced through the ICC Code development process. This will enable states to more easily adopt the Federal provisions by adopting the IBC. Otherwise, these entrapment avoidance provisions will have to be handled on a state and local level such as the case where the Florida Building Commission adopted the ANSI/APSP-7 Standard into the 2007 Florida Building Code.

Bibliography:

Title XIV Federal Pool and Spa Safety Act: Posted by the Consumer Product Safety Commission: <http://www.cpsc.gov/pssa.pdf>

"Entrapment Prevention in Pools and Spas" by Shajee Siddiqui, Published in the January-February 2008 issue of *Building Safety Journal*, copyright International Code Council, and is reprinted with permission:

http://www.apsp.org/clientresources/documents/Siddiqui_EntrapmentPools.Spas_reprint.pdf

Final Action: AS AM AMPC___ D

RB230-07/08

R301.2.1.1

Proposed Change as Submitted:

Proponent: Gary J. Ehrlich, PE, National Association of Home Builders

Revise as follows:

R301.2.1.1 (Supp) Design criteria. In regions where the basic wind speeds from Figure R301.2(4) equal or exceed 100 miles per hour (45 m/s) in hurricane-prone regions, or 110 miles per hour (49 m/s) elsewhere, the design of buildings shall be in accordance with one of the following methods. The elements of design not addressed by those documents in Items 1 through 4 shall be in accordance with this code.

1. American Forest and Paper Association (AF&PA) *Wood Frame Construction Manual for One- and Two-Family Dwellings* (WFCM); or
2. *Southern Building Code Congress International Standard for Hurricane Resistant Residential Construction* (SSTD 10); or
3. *Minimum Design Loads for Buildings and Other Structures* (ASCE-7); or
4. American Iron and Steel Institute (AISI), *Standard for Cold-Formed Steel Framing—Prescriptive Method For One- and Two-Family Dwellings (COFS/PM) with Supplement to Standard for Cold-Formed Steel Framing—Prescriptive Method For One- and Two-Family Dwellings*.
5. Concrete construction shall be designed in accordance with the provisions of this code.
6. Structural insulated panels shall be designed in accordance with the provisions of this code.
7. Where continuous structural panel sheathing in accordance with Section R602.10.4 is provided on all exterior braced wall lines on all stories, the design of buildings shall be in accordance with the provisions of this code.

Reason: As justification for their IRC code change (RB31-04/05) introducing the additional 100mph limit, IBHS noted four issues: roof sheathing nails, wind bracing requirements, toe-nailed uplift connections, and wall-to-wall connections at the floor line. In lieu of pursuing the individual modifications needed to resolve these issues within the IRC, the proponent simply lowered the ceiling for using prescriptive design provisions along the Atlantic Coast. We believe this was an excessive solution to the problem and not supported by the observed performance of housing properly constructed using any edition of the IRC and subject to extreme wind events. At no time during the code cycle did the proponents ever provide to the committee or the assembly documented evidence of failures of structures constructed to the IRC provisions. Nor did they provide technical justification in the form of engineering calculations or structural research to support their contentions. However, the code development cycle coincided with the 2004 Florida hurricanes and Hurricanes Katrina and Rita, so there was significant political and emotional pressure on the code development community to increase the stringency of building codes, whether or not they were technically justified or appropriately targeted to the risk of severe wind events in those areas subjected to the new provisions.

In both the 2004/2005 and 2006/2007 cycles, individual changes were implemented which address issues raised by IBHS. The minimum roof sheathing nailing was increased from 6d to 8d common nails for all roofs and the nail spacing in the gable and eave end zones was increased for dwellings in the 100mph region. The work of the ICC Ad-Hoc Committee on Wall Bracing in the 2006/2007 cycle resulted in a number of clarifications and improvements to the braced wall provisions. In particular, changes to the continuous sheathed method clarified return corner and uplift restraint requirements and added limits on mixing of continuous sheathing with other methods in high-wind regions. Additional changes proposed by the Ad-Hoc Committee for this cycle will further refine and revise the wall bracing provisions to insure braced wall lines are properly located, detailed and constructed and that braced wall segments are properly anchored to foundations and fastened to wall and roof framing.

This change mandates use of the continuous sheathing method for wall bracing for dwellings constructed in hurricane-prone regions in order to remain within the IRC provisions for the rest of the design of wind-resisting elements. Testing by NAHB's Research Center, APA and others shows that continuously-sheathed dwellings are substantially stronger than dwellings sheathed with intermittent bracing. Whole-building tests indicate that these dwellings have a resistance of at least double that which would be suggested by simply adding the allowable capacities of the individual walls.

The 2004/2005 change raises questions regarding the age of the damaged structures used for justifying the code change. The FEMA Summary Reports on Building Performance from the 2004 hurricane season and from Hurricane Katrina in 2005 indicated that structures built to the 2000 and 2003 IRC performed extremely well. The 2004 hurricane report stated (p.13), "no structural failures were observed to structures designed and constructed to the wind design requirements of...the 2000 IBC/IRC..." The Hurricane Katrina report stated (p.4-8), "Most structural failures observed by the MAT appeared to be the result of inadequate design and construction methods commonly used before IBC 2000 and IRC 2000 were adopted and enforced." In addition, a study conducted by the Texas Windstorm Insurance Association after Hurricane Rita showed there was substantially less damage and substantially fewer insurance claims in those areas where the 2000 or 2003 IBC and IRC were adopted and enforced.

Estimates performed by NAHB staff show that complying with the SSTD-10 and WFCM provisions can add as much as \$10,000 to the cost of a home, making it extremely difficult to construct affordable housing along the Atlantic and Gulf coasts and placing an onerous burden on builders and homeowners, particularly on first-time home buyers. This added cost of construction will have the effect of keeping residents of these coastal areas in older homes which do not have the robust construction provided by the IRC prescriptive provisions and which will be substantially more susceptible to structural failures, water infiltration and damage to personal property in high wind events. NAHB asks for your support of this proposal.

Bibliography: FEMA, *Summary Report on Building Performance, 2004 Hurricane Season*, FEMA 490, Washington, DC, March 2005.
FEMA, *Summary Report on Building Performance, Hurricane Katrina*, FEMA 548, Washington, DC, April 2006.

Cost Impact: The code change proposal will not increase the cost of construction.

Committee Action:

Approved as Modified

Modify proposal as follows:

R301.2.1.1 (Supp) Design criteria. In regions where the basic wind speeds from Figure R301.2(4) equal or exceed 100 miles per hour (45 m/s) in hurricane-prone regions, or 110 miles per hour (49 m/s) elsewhere, the design of buildings shall be in accordance with one of the following methods. The elements of design not addressed by those documents in Items 1 through 4 shall be in accordance with this code.

1. American Forest and Paper Association (AF&PA) *Wood Frame Construction Manual for One- and Two-Family Dwellings* (WFCM); or
2. *Southern Building Code Congress International Standard for Hurricane Resistant Residential Construction* (SSTD 10); or
3. *Minimum Design Loads for Buildings and Other Structures* (ASCE-7); or
4. American Iron and Steel Institute (AISI), *Standard for Cold-Formed Steel Framing—Prescriptive Method For One- and Two-Family Dwellings (COFS/PM) with Supplement to Standard for Cold-Formed Steel Framing—Prescriptive Method For One- and Two-Family Dwellings*.
5. Concrete construction shall be designed in accordance with the provisions of this code.
6. Structural insulated panels shall be designed in accordance with the provisions of this code.

7. Where continuous structural panel sheathing in accordance with Section R602.10.4 this code is provided on all exterior braced wall lines on all stories, and the basic wind speed does not exceed 110 miles per hour, the design of buildings shall be in accordance with the provisions of this code.

Committee Reason: This change recognizes continuous structural panels and permits its use for basic wind speeds up to 110 mph. The modification makes this applicable to other than wood structural panels and basic wind speeds up to 110 mph.

Assembly Action:

None

Individual Consideration Agenda

This item is on the agenda for individual consideration because public comments were submitted.

Public Comment 1:

Randall Shackelford, P.E., Simpson Strong-Tie Co., requests Disapproval.

Commenter's Reason: This code change is meant to allow IRC conventional construction in areas up to 110 miles per hour design windspeed with only one requirement: that continuous structural panel sheathing be provided at exterior braced wall lines.

By the proponents own reason statement, previous research has identified four areas where the IRC is deficient in higher wind areas:

1. Roof sheathing nails (which has been corrected in recent codes)
2. Wind bracing requirements
3. Toe-nailed uplift connectors
4. Wall to wall connections at the floor line

Of the remaining issues 2, 3, and 4, this proposal addresses NONE of them. Simply adding continuous sheathing does not ensure that an adequate amount of bracing will be present. In fact, bracing amounts are permitted to be REDUCED when continuous sheathing is installed. Also, this proposal only requires continuous sheathing at exterior braced wall lines, not all exterior walls.

There are two code changes this cycle that do address these issues, but they were denied.

RB148 is the ICC Ad Hoc Committee on Wall Bracing's change to fix the wall bracing amounts for wind. Current wall bracing amounts were calculated based on seismic resistance, and wind resistance was added as an afterthought. For many building configurations, this results in inadequate bracing to resist wind (See reason statement for RB148 for more information). This could address #2 above.

RB207 is the other code change that addresses this situation. It proposes to "fix" the wind uplift connection requirements in the IRC. That would address numbers 3 and 4 above.

Unless RB148 and RB207 are both approved, the membership is urged to deny RB230.

Public Comment 2:

T. Eric Stafford, P.E., Institute for Business and Home Safety, requests Disapproval.

Commenter's Reason: We are recommending disapproval of Code Change RB230-07/08. While the committee amendment significantly improved this modification related to conventional construction techniques in high wind regions, it still doesn't go far enough. The proponent suggested in his reason, that instead of addresses changes to the individual construction techniques (wind bracing requirements, roof-to-wall connections, etc.) we simply lowered the ceiling for using the prescriptive design provisions. As we've noted previously, the prescriptive design provisions do not provide construction methods that are capable of withstanding the design loads for wind. Even in the low wind regions, most of the prescriptive designs will not calculate to be sufficient for the applicable wind loads. The question is, at what wind speed should we allow the techniques that have historically been used, knowing that they will not be sufficient for high winds.

We have submitted, with little success, code changes every cycle to address the deficiencies in the code that the proponent had pointed out. However, they, along with many of the bracing proposals, are consistently disapproved by the IRC B/E Committee. This code cycle, we submitted RB207-07/08, which was a joint effort from a group that originally involved NAHB. RB207-07/08 was intended to address the roof-to-wall connection problems in higher wind areas for the prescriptive provisions in the IRC. While RB207-07/08 was Disapproved by the IRC B/E Committee, at this time we believe there is going to be a Public Comment submitted by NAHB that will represent a compromise between IBHS, NAHB and others on addressing the roof-to-wall connections. If that Public Comment is submitted, and Approved at the code hearings, we will drop our objection to this proposal.

Final Action: AS AM AMPC____ D

RE2-07/08, Part I

IRC N1101.2, N1104 (New), N1104.1 (New), N1104.2 (New), N1104.3 (New), N1104.4 (New), N1104.4.1 (New), N1104.4.2 (New), N1104.4.3 (New), N1104.5 (New), N1104.5.1 (New), N1104.5.2 (New), N1104.6 (New), N1104.6.1 (New), N1104.6.2 (New), N1104.6.3 (New), Table N1104.5.2(1) (New), Table N1104.5.2(2) (New);

Proposed Change as Submitted:

Proponent: Thomas D. Culp, Ph.D., Birch Point Consulting LLC; Thomas S. Zaremba, Roetzel & Andress

PART I – IRC

1. Revise as follows:

N1101.2 Compliance. Compliance shall be demonstrated by ~~either meeting the requirements of the *International Energy Conservation Code* or meeting the requirements of this chapter~~ Sections N1101, N1102.4, N1102.5, and N1103 and either:

1. Sections N1102.1 through N1102.3 (prescriptive); or
2. Section N1104 (performance).

Climate zones from Figure N1101.2 or Table N1101.2 shall be used in determining the applicable requirements from this chapter.

2. Add new text as follows:

SECTION N1104 **SIMULATED PERFORMANCE ALTERNATIVE** **(Performance)**

N1104.1 Scope. This section establishes criteria for compliance using simulated energy performance analysis. Such analysis shall include heating, cooling, and service water heating energy only.

N1104.2 Mandatory requirements. Compliance with this Section requires that the criteria of Sections N1101, N1102.4, N1102.5, and N1103 be met.

N1104.3 Performance-based compliance. Compliance based on simulated energy performance requires that a proposed residence (proposed design) be shown to have an annual energy cost that is less than or equal to the annual energy cost of the standard reference design. Energy prices shall be taken from a source approved by the code official, such as the Department of Energy, Energy Information Administration's *State Energy Price and Expenditure Report*. Code officials shall be permitted to require time-of-use pricing in energy cost calculations.

Exception: Jurisdictions that require site energy (1kWh = 3,413 Btu) rather than energy cost as the metric of comparison.

N1104.4 Documentation.

N1104.4.1 Compliance software tools. Documentation verifying that the methods and accuracy of the compliance software tools conform to the provisions of this section shall be provided to the code official.

N1104.4.2 Compliance report. Compliance software tools shall generate a report that documents that the proposed design complies in accordance with Section N1104.3. The compliance documentation shall include the following information:

1. Address or other identification of the residence;
2. An inspection checklist documenting the building component characteristics of the proposed design as listed in Table N1105.5.2(1). The inspection checklist shall show results for both the standard reference design and the proposed design, and shall document all inputs entered by the user necessary to reproduce the results;

3. Name of individual completing the compliance report; and
4. Name and version of the compliance software tool.

Exception: Multiple Orientations. When an otherwise identical building model is offered in multiple orientations, compliance for any orientation shall be permitted by documenting that the building meets the performance requirements in each of the four cardinal (north, east, south and west) orientations.

N1104.4.3 Additional documentation. The code official shall be permitted to require the following documents:

1. Documentation of the building component characteristics of the standard reference design
2. A certification signed by the builder providing the building component characteristics of the proposed design as given in Table N1104.5.2(1).

N1104.5 Calculation procedure.

N1104.5.1 General. Except as specified by this section, the standard reference design and proposed design shall be configured and analyzed using identical methods and techniques.

N1104.5.2 Residence specifications. The standard reference design and proposed design shall be configured and analyzed as specified by Table N1104.5.2(1). Table N1104.5.2(1) shall include by reference all notes contained in Table N1102.1.

N1104.6 Calculation software tools.

N1104.6.1 Minimum capabilities. Calculation procedures used to comply with this section shall be software tools capable of calculating the annual energy consumption of all building elements that differ between the standard reference design and the proposed design and shall include the following capabilities:

1. Computer generation of the standard reference design using only the input for the proposed design. The calculation procedure shall not allow the user to directly modify the building component characteristics of the standard reference design
2. Calculation of whole-building (as a single zone) sizing for the heating and cooling equipment in the standard reference design residence in accordance with Section M1401.3.
3. Calculations that account for the effects of indoor and outdoor temperatures and part-load ratios on the performance of heating, ventilating and air conditioning equipment based on climate and equipment sizing.
4. Printed code official inspection checklist listing each of the proposed design component characteristics from Table N1104.5.2(1) determined by the analysis to provide compliance, along with their respective performance ratings (e.g. R-Value, U-Factor, SHGC, HSPF, AFUE, SEER, EF, etc.).

N1104.6.2 Specific approval. Performance analysis tools meeting the applicable sections of N1104 shall be permitted to be approved. Tools are permitted to be approved based on meeting a specified threshold for a jurisdiction. The code official shall be permitted to approve tools for a specified application or limited scope.

N1104.6.3 Input values. When calculations require input values not specified by Sections N1102, N1103 and N1104, those input values shall be taken from an approved source.

**TABLE N1104.5.2(1)
SPECIFICATIONS FOR THE STANDARD REFERENCE AND PROPOSED DESIGNS**

<u>BUILDING COMPONENT</u>	<u>STANDARD REFERENCE DESIGN</u>	<u>PROPOSED DESIGN</u>
<u>Above-grade walls</u>	<u>Type: mass wall if proposed wall is mass; otherwise wood frame</u> <u>Gross area: same as proposed</u> <u>U-Factor: from Table N1102.1.2</u> <u>Solar absorptance = 0.75</u> <u>Emittance = 0.90</u>	<u>As proposed</u> <u>As proposed</u> <u>As proposed</u> <u>As proposed</u> <u>As proposed</u>
<u>Basement and crawlspace walls</u>	<u>Type: same as proposed</u> <u>Gross area: same as proposed</u> <u>U-Factor: from Table N1102.1.2 with insulation layer on interior side of walls</u>	<u>As proposed</u> <u>As proposed</u> <u>As proposed</u>
<u>Above-grade floors</u>	<u>Type: wood frame</u>	<u>As proposed</u>

BUILDING COMPONENT	STANDARD REFERENCE DESIGN	PROPOSED DESIGN
	Gross area: same as proposed <u>U-Factor: from Table N1102.1.2</u>	<u>As proposed</u> <u>As proposed</u>
<u>Ceilings</u>	Type: wood frame Gross area: same as proposed <u>U-Factor: from Table N1102.1.2</u>	<u>As proposed</u> <u>As proposed</u> <u>As proposed</u>
<u>Roofs</u>	Type: composition shingle on wood sheathing Gross area: same as proposed Solar absorptance = 0.75 Emittance = 0.90	<u>As proposed</u> <u>As proposed</u> <u>As proposed</u> <u>As proposed</u>
<u>Attics</u>	Type: vented with aperture = 1 ft ² per 300 ft ² ceiling area	<u>As proposed</u>
<u>Foundations</u>	Type: same as proposed	<u>As proposed</u>
<u>Doors</u>	Area: 40 ft ² Orientation: North <u>U-factor: same as fenestration from Table N1102.1.2</u>	<u>As proposed</u> <u>As proposed</u> <u>As proposed</u>
<u>Glazing^a</u>	Total area ^b = (a) The proposed glazing area; where the proposed glazing area is less than 18% of the conditioned floor area (b) 18% of the conditioned floor area; where the proposed glazing area is 18% or more of the conditioned floor area Orientation: equally distributed to four cardinal compass orientations (N, E, S, & W) <u>U-factor: from Table N1102.1</u> <u>SHGC: From Table N1102.1 except that for climates with no requirement (NR), SHGC = 0.40 shall be used</u> Interior shade fraction: Summer (all hours when cooling is required) = 0.70 Winter (all hours when heating is required) = 0.85 External shading: none	<u>As proposed</u> <u>As proposed</u> <u>As proposed</u> Same as standard reference design ^c <u>As proposed</u>
<u>Skylights</u>	None	<u>As proposed</u>
<u>Thermally isolated sunrooms</u>	None	<u>As proposed</u>
<u>Air exchange rate</u>	<u>Specific Leakage Area (SLA)^d = 0.00036 assuming no energy recovery</u>	For residences that are not tested, the same as the standard reference design For residences without mechanical ventilation that are tested in accordance with ASHRAE 119, Section 5.1, the measured air exchange rate ^e but not less than 0.35 ACH For residences with mechanical ventilation that are tested in accordance with ASHRAE 119, Section 5.1, the measured air exchange rate ^e combined with the mechanical ventilation rate, ^f which shall not be less than $0.01 \times CFA + 7.5 \times (Nbr+1)$ where: CFA = conditioned floor area Nbr = number of bedrooms
<u>Mechanical ventilation</u>	None, except where mechanical ventilation is specified by the proposed design, in which case: <u>Annual vent fan energy use: kWh/yr = $0.03942 \times CFA + 29.565 \times (Nbr+1)$</u>	<u>As proposed</u>

BUILDING COMPONENT	STANDARD REFERENCE DESIGN	PROPOSED DESIGN
	where: <u>CFA = conditioned floor area</u> <u>Nbr = number of bedrooms</u>	
<u>Internal gains</u>	<u>$IGain = 17,900 + 23.8 \times CFA + 4104 \times Nbr$</u> <u>(Btu/day per dwelling unit)</u>	<u>Same as standard reference design</u>
<u>Internal mass</u>	<u>An internal mass for furniture and contents of 8 pounds per square foot of floor area</u>	<u>Same as standard reference design, plus any additional mass specifically designed as a thermal storage element⁹ but not integral to the building envelope or structure</u>
<u>Structural mass</u>	<u>For masonry floor slabs, 80% of floor area covered by R-2 carpet and pad, and 20% of floor directly exposed to room air</u> <u>For masonry basement walls, as proposed, but with insulation required by Table N1102.1.2 located on the interior side of the walls</u> <u>For other walls, for ceilings, floors, and interior walls, wood frame construction</u>	<u>As proposed</u> <u>As proposed</u> <u>As proposed</u>
<u>Heating systems^{h, i}</u>	<u>Fuel type: same as proposed design</u> <u>Efficiencies:</u> <u>Electric: air-source heat pump with prevailing federal minimum efficiency</u> <u>Nonelectric furnaces: natural gas furnace with prevailing federal minimum efficiency</u> <u>Nonelectric boilers: natural gas boiler with prevailing federal minimum efficiency</u> <u>Capacity: sized in accordance with Section M1401.3</u>	<u>As proposed</u> <u>As proposed</u> <u>As proposed</u> <u>As proposed</u> <u>As proposed</u>
<u>Cooling systems^{h, j}</u>	<u>Fuel type: Electric</u> <u>Efficiency: in accordance with prevailing federal minimum standards</u> <u>Capacity: sized in accordance with Section M1401.3</u>	<u>As proposed</u> <u>As proposed</u> <u>As proposed</u>
<u>Service Water Heating^{h, k}</u>	<u>Fuel type: same as proposed design</u> <u>Efficiency: in accordance with prevailing federal minimum standards</u> <u>Use: gal/day=30 + (10 x Nbr)</u>	<u>As proposed</u> <u>As proposed</u> <u>Same as standard reference</u>
<u>Thermal distribution systems</u>	<u>A thermal distribution system efficiency (DSE) of 0.80 shall be applied to both the heating and cooling system efficiencies</u>	<u>Same as standard reference design, except as specified by Table N1104.5.2(2)</u>
<u>Thermostat</u>	<u>Type: manual,</u> <u>cooling temperature set point = 78°F;</u> <u>heating temperature set point = 68°F</u>	<u>Same as standard reference design</u>

For SI: 1 square foot = 0.93 m²; 1 British thermal unit = 1055 J; 1 pound per square foot = 4.88 kg/m²; 1 gallon (U.S.) = 3.785 L; °C = (°F-32)/1.8.

- a. Glazing shall be defined as sunlight-transmitting fenestration, including the area of sash, curbing or other framing elements, that enclose conditioned space. Glazing includes the area of sunlight-transmitting fenestration assemblies in walls bounding conditioned basements. For doors where the sunlight-transmitting opening is less than 50% of the door area, the glazing area is the sunlight transmitting opening area. For all other doors, the glazing area is the rough frame opening area for the door including the door and the frame.
- b. For residences with conditioned basements, R-2 and R-4 residences and townhouses, the following formula shall be used to determine glazing area: $AF = As \times FA \times F$
where:
AF = Total glazing area.
As = Standard reference design total glazing area.
FA = (Above-grade thermal boundary gross wall area)/(above-grade boundary wall area + 0.5 x below-grade boundary wall area).

$F = \frac{\text{Above-grade thermal boundary wall area}}{\text{above-grade thermal boundary wall area} + \text{common wall area}}$ or 0.56, whichever is greater.

and where:

Thermal boundary wall is any wall that separates conditioned space from unconditioned space or ambient conditions.

Above-grade thermal boundary wall is any thermal boundary wall component not in contact with soil.

Below-grade boundary wall is any thermal boundary wall in soil contact.

Common wall area is the area of walls shared with an adjoining dwelling unit.

- c. For fenestrations facing within 15 degrees (0.26 rad) of true south that are directly coupled to thermal storage mass, the winter interior shade fraction shall be permitted to be increased to 0.95 in the proposed design.
- d. Where Leakage Area (L) is defined in accordance with Section 5.1 of ASHRAE 119 and where:
SLA = L/CFA
where L and CFA are in the same units.
- e. Tested envelope leakage shall be determined and documented by an independent party approved by the code official. Hourly calculations as specified in the 2001 ASHRAE *Handbook of Fundamentals*, Chapter 26, page 26.21, Equation 40 (Sherman-Grimmsrud model) or the equivalent shall be used to determine the energy loads resulting from infiltration.
- f. The combined air exchange rate for infiltration and mechanical ventilation shall be determined in accordance with Equation 43 of 2001 ASHRAE *Handbook of Fundamentals* page 26.24 and the "Whole-house Ventilation" provisions of 2001 ASHRAE *Handbook of Fundamentals*, page 26.19 for intermittent mechanical ventilation.
- g. Thermal Storage Element shall mean a component not part of the floors, walls or ceilings that is part of a passive solar system, and that provides thermal storage such as enclosed water columns, rock beds, or phase-change containers. A thermal storage element must be in the same room as fenestration that faces within 15 degrees (0.26 rad) of true south, or must be connected to such a room with pipes or ducts that allow the element to be actively charged.
- h. For a proposed design with multiple heating, cooling or water heating systems using different fuel types, the applicable standard reference design system capacities and fuel types shall be weighted in accordance with their respective loads as calculated by accepted engineering practice for each equipment and fuel type present.
- i. For a proposed design without a proposed heating system, a heating system with the prevailing federal minimum efficiency shall be assumed for both the standard reference design and proposed design. For electric heating systems, the prevailing federal minimum efficiency air-source heat pump shall be used for the standard reference design.
- j. For a proposed design home without a proposed cooling system, an electric air conditioner with the prevailing federal minimum efficiency shall be assumed for both the standard reference design and the proposed design.
- k. For a proposed design with a nonstorage-type water heater, a 40-gallon storage-type water heater with the prevailing federal minimum Energy Factor for the same fuel as the predominant heating fuel type shall be assumed. For the case of a proposed design without a proposed water heater, a 40-gallon storage-type water heater with the prevailing federal minimum efficiency for the same fuel as the predominant heating fuel type shall be assumed for both the proposed design and standard reference design.

TABLE N1104.5.2(2)

DEFAULT DISTRIBUTION SYSTEM EFFICIENCIES FOR PROPOSED DESIGNS^a

<u>DISTRIBUTION SYSTEM CONFIGURATION AND CONDITION:</u>	<u>FORCED AIR SYSTEMS</u>	<u>HYDRONIC SYSTEMS^b</u>
<u>Distribution system components located in unconditioned space</u>	<u>0.80</u>	<u>0.95</u>
<u>Distribution systems entirely located in conditioned space^c</u>	<u>0.88</u>	<u>1.00</u>
<u>Proposed "reduced leakage" with entire air distribution system located in the conditioned space^d</u>	<u>0.96</u>	<u>--</u>
<u>Proposed "reduced leakage" air distribution system with components located in the unconditioned space</u>	<u>0.88</u>	<u>--</u>
<u>"Ductless" systems^e</u>	<u>1.00</u>	<u>--</u>

For SI: 1 cubic foot per minute = 0.47 L/s; 1 square foot = 0.093 m²; 1 pound per square inch = 6895 Pa; 1 inch water gauge = 1250 Pa.

- a. Default values given by this table are for untested distribution systems, which must still meet minimum requirements for duct system insulation.

- b. Hydronic Systems shall mean those systems that distribute heating and cooling energy directly to individual spaces using liquids pumped through closed loop piping and that do not depend on ducted, forced air flows to maintain space temperatures.
- c. Entire system in conditioned space shall mean that no component of the distribution system, including the air handler unit, is located outside of the conditioned space.
- d. Proposed “reduced leakage” shall mean leakage to outdoors not greater than 3 cfm per 100 ft² of conditioned floor area and total leakage not greater than 9 cfm per 100 ft² of conditioned floor area at a pressure differential of 0.02 inches w.g. (25 Pa) across the entire system, including the manufacturer’s air handler enclosure. Total leakage of not greater than 3 cfm per 100 ft² of conditioned floor area at a pressure difference of 0.02 inches w.g. (25 Pa) across the entire system, including the manufacturer’s air handler enclosure, shall be deemed to meet this requirement without measurement of leakage to outdoors. This performance shall be specified as required in the construction documents and confirmed through field-testing of installed systems as documented by an approved independent party.
- e. Ductless systems may have forced airflow across a coil but shall not have any ducted airflows external to the manufacturer’s air handler enclosure.

Reason: The purpose of this proposal is to place the residential provisions of the energy code in one place, rather than having potentially different requirements in the IRC and the IECC. To accomplish this purpose, the definition of residential buildings is modified to be consistent with the scope of the IRC, the requirements in the residential chapter are replaced with a reference to Chapter 11 of the IRC, and the residential performance alternative (section 405) is inserted without change into the IRC.

Over the last few code cycles, there have been numerous hours spent debating the same proposals before two different committees, and strong debates about whether or not the IRC and IECC requirements should always be identical. Although the IRC and IECC residential requirements are currently very similar with some small variations, they are likely to continue to deviate in the future, as they did prior to the 2004 rewrite of the code. This is an inefficient and counterproductive way to function, especially considering the extremely valuable contributions of code officials, interested parties, and the ICC organization and staff in developing these codes.

In this proposal, the commercial provisions of the code remain in the IECC. This allows the IECC committee to focus on commercial buildings, which already present very complex variations and issues, without having to try to be experts in both residential and commercial applications. The residential provisions would remain under the expertise of the IRC B/E committee, as they are today.

Currently, the IRC and IECC residential requirements are essentially the same with some small variations, so this change will not significantly change the requirements for most buildings. One difference is that apartment buildings not more than three stories above grade would now fall under the commercial provisions of the IECC, similar to apartment buildings over three stories high. This is due to the way the IRC scope is limited to one- and two-family dwellings and townhouses / rowhomes with a separate means of egress.

Finally, one of the most important reasons to adopt this proposal is that it would increase use of the residential energy code. The IRC is much more widely adopted than the IECC, and having a single residential energy code to promote and enforce is to the benefit of the public, code officials, and the ICC organization.

Cost Impact: The code change proposal will not increase the cost of construction.

PART I – IRC

Committee Action:

Disapproved

Committee Reason: This is a prescriptive code and performance requirement should not be brought in from other codes. This could lead to bringing in performance and/or design requirements from the IBC. The performance requirements are now an option and should remain in the IECC.

Assembly Action:

None

Individual Consideration Agenda

This item is on the agenda for individual consideration because public comments were submitted.

Public Comment 1:

Thomas D. Culp, Birch Point Consulting LLC, requests Approval as Submitted.

Thomas S. Zaremba, Roetzel & Andress, requests Approval as Submitted.

Commenters' Reason: Currently, residential energy building code provisions exist in Chapter 4 of the International Energy Conservation Code (IECC) and Chapter 11 of the International Residential Code (IRC). If adopted, RE2 would transfer all residential energy code provisions to Chapter 11 of the IRC. Chapter 4 of the IECC would, in turn, require compliance with Chapter 11 of the IRC. All programs, tax credits, or adoptions already referencing the IECC would be unaffected, as the IECC would still be complete and consistent, by reference to the IRC. This proposal, if adopted, would eliminate any differences between the energy provisions of the IECC and the IRC.

The IRC is a “stand-alone” residential building code. There are a number of reasons why it is important that all provisions governing residential building construction, including energy, be located in the same book. First, all of the different parts of a residential building are interrelated. The foundation is related to the walls, which are, in turn, related to the electrical, plumbing, energy and all of the other components parts of the house. The best way to ensure that all of the parts of residential construction fit together is to have all of the rules governing that construction in a single book or code. Second, the best way to ensure adoptability of a residential energy code is to include it in the IRC, the book that most local jurisdictions rely upon for residential construction. Finally, the best way to ensure code compliance and enforceability is to have all of the rules governing residential construction in a single book. Forcing builders and code officials to cross reference multiple provisions from multiple codes invites error and non-compliance.

This issue is made all the more important now since one group, actively involved in the code development process, has recently expressed its favor for the IECC over the IRC by submitting numerous proposals to change the IECC, while, in effect, boycotting development of the IRC's energy provisions. Evidently, this strategy is calculated to create a greater and greater divergence between the IECC and the energy code provisions of the IRC in the hope eliminating Chapter 11 of the IRC. Indeed, this same group authored RE3-07/08, a proposal to delete Chapter 11 of the IRC.

Internal coordination of all residential building code provisions; adoptability; code compliance; and code enforcement all speak in favor of keeping the IRC as a stand-alone residential building code.

We urge you to vote against the motion to sustain the Committees' disapproval of RE2-07/08, Parts I and II, and to vote to adopt them As Submitted.

Public Comment 2:

Ken Sagan, National Association of Home Builders, requests Approval as Submitted.

Commenter's Reason: The proposal was intended to have all provisions for residential construction in one code book, the IRC. Currently there are prescriptive requirements in Chapter 11 of the IRC. Once a builder deviates from the prescriptive requirements, there is a need to go the Chapter 4 of the IECC. Currently, some provisions are in the IRC and others in the IECC, causing confusion as to which code prevailed. This proposal, if adopted would eliminate that problem. Both the IECC and Chapter 11 of the IRC will function as stand alone documents. The net result in energy savings was the same, but become less confusing and more enforceable.

Final Action: AS AM AMPC____ D

RE2-07/08, Part II

IECC 202, 401.2, 401.3, 402, 403, 404, 405 (New)

Proposed Change as Submitted:

Proponent: Thomas D. Culp, Ph.D., Birch Point Consulting LLC; Thomas S. Zaremba, Roetzel & Andress

PART II – IECC

1. Revise as follows:

SECTION 202 GENERAL DEFINITIONS

RESIDENTIAL BUILDING. For this code, includes ~~R-3 buildings, as well as R-2 and R-4 buildings three stories or less in height above grade, detached one- and two-family dwellings or multiple single-family dwellings (townhouses) not more than three stories above-grade in height with a separate means of egress.~~

401.2 Compliance. Projects shall comply with Chapter 11 of the *International Residential Code*, Sections 401, 402.4, 402.5, 402.6 and 403 (referred to as the mandatory provisions) and either:

1. ~~Sections 402.1 through 402.3 (prescriptive); or~~
2. ~~Section 404 (performance).~~

2. Delete without substitution:

401.3 Certificate. ~~A permanent certificate shall be posted on or in the electrical distribution panel. The certificate shall be completed by the builder or registered design professional. The certificate shall list the predominant R-values of insulation installed in or on ceiling/roof, walls, foundation (slab, basement wall, crawlspace wall and/or floor) and ducts outside conditioned spaces; U-factors for fenestration; and the solar heat gain coefficient (SHGC) of fenestration. Where there is more than one value for each component, the certificate shall list the value covering the largest area. The certificate shall list the type and efficiency of heating, cooling and service water heating equipment.~~

SECTION 402 BUILDING THERMAL ENVELOPE

SECTION 403 SYSTEMS

SECTION 404 (Supp) ELECTRICAL POWER AND LIGHTING SYSTEMS

SECTION 405 (Supp)
SIMULATED PERFORMANCE ALTERNATIVE

Reason: The purpose of this proposal is to place the residential provisions of the energy code in one place, rather than having potentially different requirements in the IRC and the IECC. To accomplish this purpose, the definition of residential buildings is modified to be consistent with the scope of the IRC, the requirements in the residential chapter are replaced with a reference to Chapter 11 of the IRC, and the residential performance alternative (section 405) is inserted without change into the IRC.

Over the last few code cycles, there have been numerous hours spent debating the same proposals before two different committees, and strong debates about whether or not the IRC and IECC requirements should always be identical. Although the IRC and IECC residential requirements are currently very similar with some small variations, they are likely to continue to deviate in the future, as they did prior to the 2004 rewrite of the code. This is an inefficient and counterproductive way to function, especially considering the extremely valuable contributions of code officials, interested parties, and the ICC organization and staff in developing these codes.

In this proposal, the commercial provisions of the code remain in the IECC. This allows the IECC committee to focus on commercial buildings, which already present very complex variations and issues, without having to try to be experts in both residential and commercial applications. The residential provisions would remain under the expertise of the IRC B/E committee, as they are today.

Currently, the IRC and IECC residential requirements are essentially the same with some small variations, so this change will not significantly change the requirements for most buildings. One difference is that apartment buildings not more than three stories above grade would now fall under the commercial provisions of the IECC, similar to apartment buildings over three stories high. This is due to the way the IRC scope is limited to one- and two-family dwellings and townhouses / rowhomes with a separate means of egress.

Finally, one of the most important reasons to adopt this proposal is that it would increase use of the residential energy code. The IRC is much more widely adopted than the IECC, and having a single residential energy code to promote and enforce is to the benefit of the public, code officials, and the ICC organization.

Cost Impact: The code change proposal will not increase the cost of construction.

PART II – IECC
Committee Action:

Disapproved

Committee Reason: Proponent requested disapproval in light of action on RE2 Part I.

Assembly Action:

None

Individual Consideration Agenda

This item is on the agenda for individual consideration because a public comment was submitted.

Public Comment:

Thomas D. Culp, Birch Point Consulting LLC, requests Approval as Submitted.

Thomas S. Zaremba, Roetzel & Andress, requests Approval as Submitted.

Commenters' Reason-Culp, Zaremba: Currently, residential energy building code provisions exist in Chapter 4 of the International Energy Conservation Code (IECC) and Chapter 11 of the International Residential Code (IRC). If adopted, RE2 would transfer all residential energy code provisions to Chapter 11 of the IRC. Chapter 4 of the IECC would, in turn, require compliance with Chapter 11 of the IRC. All programs, tax credits, or adoptions already referencing the IECC would be unaffected, as the IECC would still be complete and consistent, by reference to the IRC. This proposal, if adopted, would eliminate any differences between the energy provisions of the IECC and the IRC.

The IRC is a "stand-alone" residential building code. There are a number of reasons why it is important that all provisions governing residential building construction, including energy, be located in the same book. First, all of the different parts of a residential building are interrelated. The foundation is related to the walls, which are, in turn, related to the electrical, plumbing, energy and all of the other components parts of the house. The best way to ensure that all of the parts of residential construction fit together is to have all of the rules governing that construction in a single book or code. Second, the best way to ensure adoptability of a residential energy code is to include it in the IRC, the book that most local jurisdictions rely upon for residential construction. Finally, the best way to ensure code compliance and enforceability is to have all of the rules governing residential construction in a single book. Forcing builders and code officials to cross reference multiple provisions from multiple codes invites error and non-compliance.

This issue is made all the more important now since one group, actively involved in the code development process, has recently expressed its favor for the IECC over the IRC by submitting numerous proposals to change the IECC, while, in effect, boycotting development of the IRC's energy provisions. Evidently, this strategy is calculated to create a greater and greater divergence between the IECC and the energy code provisions of the IRC in the hope eliminating Chapter 11 of the IRC. Indeed, this same group authored RE3-07/08, a proposal to delete Chapter 11 of the IRC.

Internal coordination of all residential building code provisions; adoptability; code compliance; and code enforcement all speak in favor of keeping the IRC as a stand-alone residential building code.

We urge you to vote against the motion to sustain the Committees' disapproval of RE2-07/08, Parts I and II, and to vote to adopt them As Submitted.

Final Action: AS AM AMPC____ D

RE3-07/08 N1101, N1102, N1103

Proposed Change as Submitted:

Proponent: Brian Dean, ICF International, representing the Energy Efficient Codes Coalition; Bill Prindle, American Council for an Energy Efficient Economy (ACEEE); Jeff Harris, Alliance to Save Energy (ASE); Steven Rosenstock, Edison Electric Institute (EEI)

Delete Sections N1101, N1102 and N1103 in their entirety and substitute as follows:

SECTION N1101

N1101.1 General. Residential buildings shall comply with the *International Energy Conservation Code (IECC)*.

Reason: This code change is intended to simplify the code development process and increase consistency and enforceability in the energy efficiency requirements.

The IECC is the nationally-recognized energy efficient building code for residential buildings. It is referenced numerous times in federal law, including as a basis for tax credits. Federal law requires states to consider adoption of the latest version of the IECC, once DOE has determined that it is an improvement over previous versions.

The IBC already references the IECC, rather than creating a separate, independent energy code chapter. A similar approach is reasonable for the IRC. It should be noted that the IRC already recognizes the IECC as an option.

The current process requires coordination in language and requirements. At a minimum, this is a time and resource consuming process, since many code changes have to be heard twice, once by the IECC committee and then by the IRC committee; as well as twice at the final action hearings. Moreover, actual coordination may not be achieved, resulting in an IECC and IRC that differ. These differences violate ICC procedures requiring consistency.

The existence of two versions of residential building energy requirements (one in the IECC and one in the IRC) also creates confusion when the codes are adopted and enforced. Advocates who support the IECC may be forced to oppose adoption of the IRC without amendments. If a jurisdiction adopts both the IECC and IRC, it may establish inconsistent requirements leading to confusion in the field and compliance and enforcement problems.

By having a single document focused on the energy efficiency of buildings, better coordination and reduced confusion between the documents will occur.

Cost Impact: The code change proposal will not increase the cost of construction. The code change proposal will decrease the cost to create and modify code language.

Committee Action:

Disapproved

Committee Reason: This is consistent with the committee's action on RE2-07/08. The IRC is a prescriptive code and this would remove the prescriptive energy requirements. Also, one of the purposes of the IRC is affordability and that is not a purpose of the IECC.

Assembly Action:

None

Individual Consideration Agenda

This item is on the agenda for individual consideration because a public comment was submitted.

Public Comment:

The following list of individuals requests Approval as Submitted.

Brian Dean, ICF International, Energy Efficient Code Coalition (EECC)

Jeff Harris, Alliance to Save Energy

Harry Misuriello, American Council for Energy Efficient Economy

Bill Prindle, EECC

Steven Rosenstock, Edison Electric Institute

Commenter's Reason—Dean, Harris, Misuriello, Prindle, Rosenstock: The existence of a set of residential energy requirements in the *IRC* that are inconsistent with and less stringent than the provisions of the *IECC* creates confusion and potential enforcement problems, as well as undercutting the adoption of the nation's model energy code, the *IECC*, at the societal cost of not saving energy nationwide. RE 3 would solve these problems. At the Palm Springs hearings, some expressed concern that the *IRC* needs a residential energy chapter with specific requirements rather than simply a reference to the *IECC*. There are two answers to this concern. First, the present *IRC* energy chapter references the *IECC* as an alternative compliance option; in short, the *IRC* volume is not truly stand-alone regardless of action on RE3. Second, if the *IRC* volume needs to physically contain a detailed energy chapter, why not simply reprint *IECC* chapters 2 – 4 in the *IRC*?

By adopting RE 3, the ICC would unify the energy efficiency requirements of the *IBC*, *IRC* and *IECC* into a single document that complies with all three codes and ensures that all three codes meet the same energy efficiency and building quality standards in the future. RE 3 also ensures that the *IRC* energy efficiency chapter keeps pace with the code designated by Congress to be the model for energy efficiency – the

IECC. Moreover, the ICC would conserve substantial time and other resources by avoiding duplicative hearings before the *IECC* and *IRC* committees. Finally, unlike the *IECC* Development Committee, energy issues are not the primary focus or expertise of the *IRC* Development Committee.

The *IECC* is the National “Gold Standard” for Energy Efficiency.

The *IECC* is recognized nationwide as the national model energy code. The *IECC* and its predecessor, the *Model Energy Code (MEC)*, are cited throughout federal law. Under the federal law, the U.S. Department of Energy (DOE) is required to review each new version of the *IECC* and determine if it is an improvement in energy efficiency over previous versions. The *IECC* also serves as the basis for federal tax credits for energy efficient homes, energy efficiency standards for federal residential buildings and manufactured housing, state energy code determinations, and qualification for FHA and other government-backed mortgages. Not one of these laws even references the *IRC*. The *IECC* is the logical selection as the single energy efficiency standard for residential buildings for the ICC as well.

Consistency Between the *IBC*, *IECC*, and *IRC*.

The *IRC* already allows builders to meet the requirements of the *IECC* as a method of compliance. Specifically, *IRC* section N1101.2 allows builders to use either the prescriptive or performance requirements of the *IECC* to show compliance with the *IRC*. Thus, since the *IECC* also contains a simple prescriptive compliance path, RE 3 does not eliminate the availability of such a compliance approach. Moreover, reference to the *IECC* also provides a more complex performance path specifically integrated with the prescriptive path as an option. The prescriptive path that is currently in the *IRC* is duplicative and unnecessary, and more importantly, it is also less stringent than the requirements of the *IBC* or *IRC*. Two different sets of code requirements increase the risk of inconsistency and uncertainty among builders and code officials. For example, when a jurisdiction adopts both the *IECC* and *IRC* without amendment, with different requirements in each code, is the user required to comply with the values of the *IECC* or *IRC*?

The *IBC* serves as a good model for the solution to this problem: *IBC* chapter 13 (Energy Efficiency) simply references the *IECC* for energy efficiency requirements. “Buildings shall be designed and constructed in accordance with the International Energy Conservation Code.” This is the simplest solution that would bring consistency to all three codes, and it has good precedent in the I-codes already.

Streamlined Enforcement.

Once all three I-codes have a unified set of energy efficiency requirements, training, compliance and enforcement will become simpler and more efficient. A builder complying with the *IRC* Chapter 11 will also meet the requirements of the *IBC* and *IECC*. Builders will only need to follow one set of requirements, and code officials can enforce a single set of requirements.

Simplified Determinations in States.

States are required by federal law to undertake a review of the state energy code and determine whether state energy efficiency requirements meet the stringency of the *IECC* every time the Department of Energy makes a determination on the updated *IECC*. 42 U.S.C. § 6833(a). For states that have adopted the *IECC* as the exclusive energy efficiency code (like Georgia), the determination is simple. States that allow less stringent methods of compliance (such as the *IRC*) add unnecessary complications to the determination process.

Less Complicated Code Hearings.

RE3 would eliminate a good deal of redundancy in the current code development process by centralizing the energy efficiency requirements in a single committee. Rather than force proponents and code officials to endure hours – even days – of the same testimony before two different committees, RE3 would streamline the process and yield a more consistent result.

We urge approval of RE3 as submitted.

Final Action: AS AM AMPC_____ D

RE6-07/08

Table N1102.1, Table N1102.1.2

Proposed Change as Submitted:

Proponent: Martha G. VanGeem, CTL Group, representing the Masonry Alliance for Codes and Standards

Revise as follows:

**TABLE N1102.1
INSULATION AND FENESTRATION REQUIREMENTS BY COMPONENT^a**

Climate Zone	Fenestration U-Factor	Skylight ^b U-Factor	Glazed Fenestration SHGC	Ceiling R-Value	Wood Frame Wall R-value	Mass Wall R-value ^h	Floor R-Value	Basement ^c Wall R-Value	Slab ^d R-value & Depth	Crawl Space ^c Wall r-value
1	1.20	0.75	0.40	30	13	3/4	13	0	0	0
2	0.75-	0.75	0.40	30	13	4/6	13	0	0	0
3	0.65	0.65	0.40 ^e	30	13	5/8	19	0	0	5/13
4 except Marine	0.40	0.60	NR	38	13	5/10	19	10/13	10, 2 ft	10/13
5 and Marine 4	0.35	0.60	NR	38	19 or 13+5 ^g	13/13	30 ^f	10/13	10, 2 ft	10/13
6	0.35	0.60	NR	49	19 or 13+5 ^g	15/19	30 ^f	10/13	10, 4 ft	10/13
7 and 8	0.35	0.60	NR	49	21	19/21	30 ^f	10/13	10, 4 ft	10/13

- a. *R*-values are minimums. *U*-factors and SHGC are maximums. R-19 insulation shall be permitted to be compressed into a 2× 6 cavity.
- b. The fenestration *U*-factor column excludes skylights. The solar heat gain coefficient (SHGC) column applies to all glazed fenestration.
- c. The first *R*-value applies to continuous insulation, the second to framing cavity insulation; either insulation meets the requirement.
- d. R-5 shall be added to the required slab edge *R*-values for heated slabs.
- e. There are no solar heat gain coefficient (SHGC) requirements in the Marine Zone.
- f. Or insulation sufficient to fill the framing cavity, R-19 minimum.
- g. “13+5” means R-13 cavity insulation plus R-5 insulated sheathing. If structural sheathing covers 25% or less of the exterior, R-5 sheathing is not required where structural sheathing is used. If structural sheathing covers more than 25% of exterior, structural sheathing shall be supplemented with insulated sheathing of at least R-2.
- h. The second R-value applies when more than half the insulation is on the interior.

**TABLE N1102.1.2
EQUIVALENT U-FACTORS^a**

Climate Zone	Fenestration U-Factor	Skylight U-Factor	Ceiling U-Factor	Frame Wall U-Factor	Mass Wall U-Factor ^b	Floor U-Factor	Basement Wall U-Factor	Crawl Space Wall U-Factor
1	1.20	0.75	0.035	0.082	0.197	0.064	0.360	0.477
2	0.75-	0.75	0.035	0.082	0.165	0.064	0.360	0.477
3	0.65	0.65	0.035	0.082	0.141	0.047	0.360	0.136
4 except Marine	0.40	0.60	0.030	0.082	0.141	0.047	0.059	0.065
5 and Marine 4	0.35	0.60	0.030	0.060	0.082	0.033	0.059	0.065
6	0.35	0.60	0.026	0.060	0.060	0.033	0.059	0.065
7 and 8	0.35	0.60	0.026	0.057	0.057	0.033	0.059	0.065

- a. Nonfenestration *U*-factors shall be obtained from measurement, calculation or an approved source.
- b. When more than half the insulation is on the interior, the mass wall U-factors shall be a maximum of 0.17 in zone 1, 0.14 in zone 2, 0.12 in zone 3, 0.10 in zone 4 except Marine, 0.082 in zone 5 and Marine 4, and the same as the frame wall U-factor zones 6 through 8.

N1102.1.2 U-factor alternative. An assembly with a *U*-factor equal to or less than that specified in Table N1102.1.2 shall be permitted as an alternative to the *R*-value in Table N1102.1.

Exception: For mass walls not meeting the criterion for insulation location in Section N1102.2.3, the *U*-factor shall be permitted to be:

1. ~~*U* factor of 0.17 in Climate Zone 1~~
2. ~~*U* factor of 0.14 in Climate Zone 2~~
3. ~~*U* factor of 0.12 in Climate Zone 3~~
4. ~~*U* factor of 0.10 in Climate Zone 4 except Marine~~
5. ~~*U* factor of 0.082 in Climate Zone 5 and Marine 4~~

N1102.2.3 Mass walls. Mass walls, for the purposes of this chapter, shall be considered above-grade walls of concrete block, concrete, insulated concrete form (ICF), masonry cavity, brick (other than brick veneer), earth (adobe, compressed earth block, rammed earth) and solid timber/logs. ~~The provisions of Section N1102.1 for mass walls shall be applicable when at least 50 percent of the required insulation *R* value is on the exterior of, or integral to, the wall. Walls that do not meet this criterion for insulation placement shall meet the wood frame wall insulation requirements of Section N1102.1.~~

Exception: For walls that do not meet this criterion for insulation placement, the minimum added insulation *R*-value shall be permitted to be:

1. ~~*R* value of 4 in Climate Zone 1~~
2. ~~*R* value of 6 in Climate Zone 2~~
3. ~~*R* value of 8 in Climate Zone 3~~
4. ~~*R* value of 10 in Climate Zone 4 except Marine~~
5. ~~*R* value of 13 in climate Zone 5 and Marine 4~~

Reason: This code change proposal simplifies the format of the mass wall requirements to match the format of the IECC.

Cost Impact: The code change proposal will not increase the cost of construction.

Committee Action:

Approved as Submitted

Committee Reason: This change brings the exception for mass into Table N1102.1. Also, this provides additional technical data.

Assembly Action:

None

Individual Consideration Agenda

This item is on the agenda for individual consideration because a public comment was submitted.

Public Comment:

Craig Conner, Building Quality, representing himself, requests Approval as Modified by this Public Comment.

Modify proposal as follows:

**TABLE N1102.1
INSULATION AND FENESTRATION REQUIREMENTS BY COMPONENT^a**

Climate Zone	Fenestration U-Factor	Skylight ^b U-Factor	Glazed Fenestration SHGC	Ceiling R-Value	Wood Frame Wall R-value	Mass Wall R-value ^h	Floor R-Value	Basement ^c Wall R-Value	Slab ^d R-value & Depth	Crawl Space ^c Wall r-value
1	1.20	0.75	0.40	30	13	3/4	13	0	0	0
2	0.75-	0.75	0.40	30	13	4/6	13	0	0	0
3	0.65	0.65	0.40 ^e	30	13	5/8	19	0	0	5/13
4 except Marine	0.40	0.60	NR	38	13	5/10	19	10/13	10, 2 ft	10/13
5 and Marine 4	0.35	0.60	NR	38	19 or 13+5 ^g	13/13 17	30 ^f	10/13	10, 2 ft	10/13
6	0.35	0.60	NR	49	19 or 13+5 ^g	15/19	30 ^f	10/13	10, 4 ft	10/13
7 and 8	0.35	0.60	NR	49	21	19/21	30 ^f	10/13	10, 4 ft	10/13

(No change to footnotes)

**TABLE N1102.1.2
EQUIVALENT U-FACTORS^a**

(Portions of table not shown remain unchanged)

- a. (No change)
- b. When more than half the insulation is on the interior, the mass wall U-factors shall be a maximum of 0.17 in zone 1, 0.14 in zone 2, 0.12 in zone 3, 0.10 in zone 4 except Marine, ~~0.082 in zone 5 and Marine 4~~, and the same as the frame wall U-factor in Marine zone 4 and zones 6 through 8.

(Portions of proposal not shown remain unchanged)

Commenter's Reason: The International Codes (I-codes) need to be internally consistent. The I-codes provide the foundation for the building codes adopted by most U.S. cities, and states, as well as some countries. Although adopting entities can, and do, amend the I-codes, the adopting jurisdictions expect a set of model codes that are internally consistent. Prior to the current code development cycle, the residential IECC and IRC energy requirements were identical in most areas. However, this development cycle introduced many potential inconsistencies. These inconsistencies are substantial enough to affect code usability. To be effective and enforceable, the IECC and IRC need to be consistent.

The table below shows the public comments designed to realign the IECC and IRC residential energy requirements to ensure internal consistency. The code development process deals with each code change separately, so realignment requires multiple comments.

The method suggested for aligning the IECC and IRC falls into one of these categories:

- A code change was submitted to the IECC without a parallel comment on the same text in the IRC. At this stage, the code development process does not allow a change unless there was an initial public comment, so realigning the codes means rejecting any comment that would create an inconsistency. The IECC committee already rejected most proposed changes that lacked an IRC version. About six more such rejections are needed to align the two codes. Of course the proponent can come back in the next code development cycle and propose the same comment for both the IECC and IRC.
- The code change was approved in one code and disapproved in the other. The best option is usually to disapprove the change in both codes or approve the same version in both codes.
- Different versions of a requirement were approved in the two codes. Different versions were approved in only two cases. A "compromise" is suggested in both cases.

- The code change was submitted for only one code, but corrects an existing difference between the IECC and IRC. Approving these changes aligns the two codes.
- The code changes were treated the same way in both codes—either approved or disapproved. In this case there is consistency, and no change is needed to align the IECC and IRC. Those code changes are not listed in the table

Inconsistencies in the IRC & IECC Requirements

Key: AS=Approved as Submitted
 AM=Approved as Modified
 AMPC=Approved as Modified by Public Comment
 D=Disapproved

#	Topic	IECC change	IRC change
EC6	Specific items made mandatory, rather than subject performance, even for "above code programs"	IECC AS. Request D in IECC.	No aligning IRC change possible, must change IECC
EC14 & EC154	Extensive package of changes	IECC D	No aligning IRC change possible, must keep IECC D
EC15	Mark R19 bats for actual performance in wall cavity	IECC AM	Request AMPC to align with IECC
EC16 & EC18	Lower maximum fenestration U-factors in southern Zones	IECC EC16 AS. Request EC18 AMPC to put compromise values in IECC.	No IRC version of EC16. Request EC18 AMPC to put compromise values in IRC
EC22 & EC26	Lower maximum SHGC in Zones 1 to 3	IECC EC26 AM. Request EC22 AMPC to put compromise values in IECC.	No IRC version of EC26. Request EC22 AMPC to put compromise values in IRC.
EC33	Increase basement insulation in Zones 6 to 8	IECC AS. Request D.	No aligning IRC change possible, must change IECC
EC35	Increase floor insulation in Zone 7 and 8	IECC AS. Request D.	No aligning IRC change possible, must change IECC
EC36	Add basement insulation in portion of Zone 3	IECC AS	Request AS in IRC also
EC37	Set insulation depth for heated slabs in Zones 1 to 3	IECC AM	Request AMPC to align with IECC
EC42	Removes ground conductance from basement wall U-factor calculations	IECC AM	Request AMPC to align with IECC
EC46	Limit ceiling areas eligible for reduced R-value due to framing restriction	IECC AS. Request D.	No aligning IRC change possible, must change IECC
EC48	Require vertical attic access meet exterior door requirement	IECC D	IRC AM. Request D.
EC50	Modifies the requirement for continuous insulation over steel framing in Zones 1 & 2	IECC AM	Request AMPC to align with IECC
EC51	Add steel framing insulation option equivalent to R-13 walls	IECC D. Committee suggested "fix". Request AMPC with fix.	IRC AS. Request AMPC to align with IECC and "fix".
EC58	Limit door area exempt from the code to 25 ft ²	IECC AM. Request D also in IECC.	IRC D
EC60	Add "rim joists" to list of areas to be air sealed	IECC AM	Request AMPC to align with IECC
EC64	Add requirements for air sealing & insulation quality installation. Require blower door OR visual inspection. Require fireplace doors & external combustion air.	IECC AM	Request AMPC to align with IECC
EC68	Require programmable thermostat	IECC AM	Request AMPC to align with IECC
EC69	Require a high efficiency furnace blower	IECC AM	Request AMPC to align with IECC
EC70	Add optional metric for manufacturer to show air handler is sealed	IECC AS	Request AS in IRC also
EC71	Require ducts tested OR indoors	IECC AS	Request AS in IRC also
EC74	Increase mechanical pipe insulation from R-2 to R-3	IECC AS	Request AS in IRC also
EC79	Require electronic ignition for gas water heaters	IECC AS	Request AS in IRC also
EC81 & EC82	Require pool heater controls & pool covers. Prohibit continuous pilot light.	IECC EC82 AS	Request AMPC with EC81 to align with existing IECC
RE5 & RE6	Realign IRC mass wall insulation requirements with IECC	No IECC change needed	Request AMPC with RE6 to align with existing IECC
RE8	Require IC (insulation contact) and "air tight" recessed lighting	No IECC change needed	Request AS to align with existing IECC

Energy efficiency is becoming markedly more important. Fortunately, the code changes that saved the most energy were usually written for both codes, allowing a substantial overall increase in energy efficiency for both the 2009 IECC and IRC. With these changes, the two codes will be much more consistent, easier to implement and more energy efficient.

RE6 alignment: RE6 was Approved as Submitted in the IRC. This format change was implemented in the IECC in the last code development cycle. RE6 realigned this part of the IECC and IRC; however, two values were missed. To realign the two codes, RE6 should be Approved as Modified by this comment.

RE6 content: RE6 revises the format of the requirements for mass walls (thermal mass) such as concrete walls. This same format change was implemented in the IECC in the last code development cycle. RE6 missed two differences between the IECC and IRC, both corrected by this comment. In the "Mass Wall" column of Table N1102.1, the first R-value (insulation on the exterior of the mass) should always be smaller than the second R-value (insulation on the interior of the mass). As approved, RE6 had one incorrect zone. Correcting that zone aligns the IECC and IRC. Likewise, the footnote was corrected to match the IECC. Because this change was already made to the IECC in the last code cycle, a parallel IECC comment is not needed.

Approving this Modification would yield the same result as originally requested by the US Department of Energy and myself in RE5.

Final Action: AS AM AMPC___ D

RE8-07/08

N1102.4.3

Proposed Change as Submitted:

Proponent: Chuck Murray, Washington State University Extension Energy Program, representing Northwest Energy Code Group

Revise as follows:

N1102.4.3 Recessed lighting. Recessed luminaires installed in the building thermal envelope shall be sealed to limit air leakage between conditioned and unconditioned spaces. All recessed luminaires shall be IC-rated and labeled as meeting ASTM E 283 when tested at 1.57 psi (75 Pa) pressure differential with no more than 2.0 cfm (0.944 L/s) of air movement from the conditioned space to the ceiling cavity. All recessed luminaires and shall be sealed with a gasket or caulk between the housing and the interior wall or ceiling covering. ~~By being:~~

- ~~1. IC rated and labeled with enclosures that are sealed or gasketed to prevent air leakage to the ceiling cavity or unconditioned space; or~~
- ~~2. IC rated and labeled as meeting ASTM E 283 when tested at 1.57 pounds per square foot (75 Pa) pressure differential with no more than 2.0 cubic feet per minute (0.944 L/s) of air movement from the conditioned space to the ceiling cavity; or~~
- ~~3. Located inside an airtight sealed box with clearances of at least 0.5 inch (13 mm) from combustible material and 3 inches (76 mm) from insulation.~~

Reason: This language is included in the 2007 supplement to the IECC. It is being submitted here for consistency.

Air leakage testing for recessed fixtures has been an option for compliance in energy codes since 1991. At that time the fixtures market was not ready for mandatory testing of all fixtures, so alternatives were included in the code. In 2005, the California Energy Code mandated testing of all recessed luminaires. This made a significant change in the market place. This market is now ready for a uniform standard for air sealing, verified through testing.

Inspections and building air leakage testing by WSU noted that even when sealed luminaires are used, air leakage will occur if the luminaires are not properly sealed to the wall or ceiling covering. Text has been added to emphasize the importance of installation practices that include sealing details. We do not think this is a new requirement, simply a clarification.

Luminaires installed in airtight sealed box are inside the thermal envelope. This application would not require air tight luminaires. The code text for option 3 is not needed.

The purpose of the code change proposal is to require testing of all recessed luminaires installed in insulated assembly. Add a requirement to seal the fixture to the penetration in the assembly. Delete unneeded text.

Cost Impact: The code change proposal will increase the cost of construction.

Committee Action:

Disapproved

Committee Reason: The language is not clear and needs additional work. There is a test standard that references back to a test and that should not be in the code. This requirement should not apply in all recessed luminaires.

Assembly Action:

None

Individual Consideration Agenda

This item is on the agenda for individual consideration because public comments were submitted.

Public Comment 1:

Craig Conner, Building Quality, requests Approval as Submitted.

Commenter's Reason: *Jurisdictions legitimately expect the I-codes to be an internally consistent family of model codes that they can use as the foundation for their own building code. This change is one of a series of changes intended to correct a large number of inconsistencies in the residential energy requirements in the IECC and IRC. Greater detail is provided in the reason statements for EC6 and RE6.*

RE8 alignment: RE8 aligns this IRC section on residential lighting with the IECC section on the same topic. To realign the two codes, RE8 should be Approved as Submitted.

RE8 content: RE8 duplicates the existing IECC Section 402.4.3 on recessed lighting. With this change, the IECC and IRC will have a uniform standard for air sealing recessed lighting. The IRC committee commented that an incorrect test standard is referenced, but this change does not change the test standard already in the code.

Public Comment 2:

Chuck Murray, Washington State University Energy Program, requests Approval as Submitted.

Commenter's Reason: The proposed modification is included in the 2007 IECC supplement. For consistency, we are seeking approval from the voting membership in the IRC for the reasons stated in the original proposal.

Final Action: AS AM AMPC_____ D
