

REVISION RECORD FOR THE STATE OF CALIFORNIA

ERRATA

January 1, 2008

2007 Title 24, Part 2, California Building Code

**PLEASE NOTE: The date of this errata is for identification purposes only.
See the History Note Appendix for the adoption and effective dates of the provisions.
Insert this errata (Jan. 1, 2008) before inserting any subsequent supplements.**

It is suggested that the section number as well as the page number be checked when inserting this material and removing the superseded material. In case of doubt, rely on the section numbers rather than the page numbers because the section numbers must run consecutively.

It is further suggested that the material be retained with this revision record sheet so that the prior wording of any section can be easily ascertained.

Please keep the removed pages with this revision page for future reference.

Note

Due to the fact that the application date for a building permit establishes the California Building Standards code provisions that are effective at the local level, which apply to the plans, specifications, and construction for that permit, it is strongly recommended that the removed pages be retained for historical reference.

Volume 1

Remove Existing Pages

7 and 8
11 and 12
21 and 22
37 and 38
43 and 44
113 and 114
133 and 134
137 and 138
237 and 238
341 and 342
349 and 350

Insert Buff Pages

7 and 8
11 and 12
21 and 22
37 and 38
43 and 44
113 and 114
133 and 134
137 and 138
237 and 238
341 and 342
349 and 350

Volume 1—(continued)

Remove Existing Pages

367 and 368
407 through 410
433 and 434
439 and 440
455 and 456
461 and 462
467 through 472
499 and 500
545 and 546
607 through 610
639 and 640

Insert Buff Pages

367 and 368
407 through 410
433 and 434
439 and 440
455 and 456
461 and 462
467 through 472
499 and 500
545 and 546
607 through 610
639 and 640

**SECTION 106
DEPARTMENT OF FOOD AND AGRICULTURE**

106.1 *Specific scope of application of the agency responsible for enforcement, the enforcement agency and the specific authority to adopt and enforce such provisions of this code, unless otherwise stated.*

Application—Dairies and places of meat and poultry inspection.

Enforcing agency—Department of Food and Agriculture.

Authority cited—Food and Agricultural Code Sections 18735, 18960, 19384, 33481 and 33731.

Reference—Food and Agricultural Code Sections 18735, 18960, 19384, 33481 and 33731.

**SECTION 107
DEPARTMENT OF HEALTH SERVICES**

107.1 *Specific scope of application of the agency responsible for enforcement, the enforcement agency and the specific authority to adopt and enforce such provisions of this code, unless otherwise stated.*

Department of Health Services.

Application—Organized camps, laboratory animal quarters, public swimming pools, radiation protection and producing facilities, commissaries serving mobile food preparation vehicles, wild animal quarantine facilities, shellfish facilities and food establishments.

Enforcing agency—The Department of Health Services and the local health agencies.

Authority cited—Health and Safety Code Sections 1660, 18897.2, 100275, 110065, 112165, 113710, 114304, 115061, 116050 and 121795.

Reference—Health and Safety Code Sections 1650, 1660, 18897.2, 18897.4, 18897.7, 100150, 100275, 110065, 113705, 113710, 114825, 114965, 115061, 116050, 116503, 112165 and 121795.

**SECTION 108
DEPARTMENT OF HOUSING AND COMMUNITY
DEVELOPMENT**

108.1 Purpose. *The purpose of this code is to establish the minimum requirements necessary to protect the health, safety and general welfare of the occupants and the public by governing accessibility, erection, construction, enlargement, conversion, alteration, repair, moving, removal, demolition, occupancy, use, height, court, area, sanitation, ventilation, maintenance, safety to life and property from fire and other hazards attributed to the built environment.*

108.2 Authority and abbreviations.

108.2.1 General. *The Department of Housing and Community Development is authorized by law to promulgate and adopt building standards and regulations for several types of building applications. These applications are grouped*

and identified by abbreviation in the Matrix Adoption Tables to show which model code sections and amendments are applicable to each application. The applications under the authority of the Department of Housing and Community Development are listed in Sections 108.2.1.1 through 108.2.1.3.

108.2.1.1 Housing construction. *Application—Hotels, motels, lodging houses, apartment houses, dwellings, dormitories, condominiums, shelters for homeless persons, congregate residences, employee housing, factory-built housing and other types of dwellings containing sleeping accommodations with or without common toilet or cooking facilities including accessory buildings, facilities, and uses thereto. Sections of this code which pertain to applications listed in this section are identified in the Matrix Adoption Table using the abbreviation “HCD 1.”*

Enforcing agency—Local building department or the Department of Housing and Community Development.

Authority cited—Health and Safety Code Sections 17921, 17922 and 19990.

Reference—Health and Safety Code Sections 17000 through 17060, 17910 through 17990 and 19960 through 19997.

108.2.1.2 Housing accessibility. *Application - Covered multifamily dwelling units as defined in Chapter 11A including, but not limited to, lodging houses, dormitories, timeshares, condominiums, shelters for homeless persons, congregate residences, apartment houses, dwellings, employee housing, factory-built housing and other types of dwellings containing sleeping accommodations with or without common toilet or cooking facilities.*

Sections of this code identified in the Matrix Adoption Table by the abbreviation “HCD 1-AC” require specific accommodations for persons with physical disabilities, as defined in Chapter 11A. The application of such provisions shall be in conjunction with other requirements of this code and apply only to Group R occupancies which are newly constructed covered multifamily dwellings as defined in Chapter 11A of the California Building Code. “HCD 1-AC” applications include, but are not limited to, the following:

1. All newly constructed covered multifamily dwellings as defined in Chapter 11A.
2. New common use areas as defined in Chapter 11A serving existing covered multifamily dwellings.
3. Additions to existing buildings, where the addition alone meets the definition of a “Covered multifamily dwelling” as defined in Chapter 11A.
4. Common use areas serving covered multifamily dwellings.

“HCD 1-AC” building standards generally do not apply to public use areas or public accommodations

such as hotels and motels. Public use areas, public accommodations and housing which is publicly funded as defined in Chapters 2, 11A and 11B of this code are subject to the Division of the State Architect (DSA-AC) and are referenced in Section 109.1.

Enforcing agency—Local building department or the Department of Housing and Community Development.

Authority cited—Health and Safety Code Sections 17921, 17922 and 19990 and Government Code Section 12955.1.

Reference—Health and Safety Code Sections 17000 through 17060, 17910 through 17990 and 19960 through 19997 and Government Code Section 12955.1.

108.2.1.3 Permanent buildings in mobilehome parks and special occupancy parks. Application-Permanent buildings, and permanent accessory buildings or structures, constructed within mobilehome parks and special occupancy parks that are under the control and ownership of the park operator. Sections of this code which pertain to applications listed in this section are identified in the Matrix Adoption Table using the abbreviation “HCD 2.”

Enforcing agency—Local building department or other local agency responsible for the enforcement of Health and Safety Code Division 13, Part 2.1 commencing with Section 18200 for mobilehome parks and Health and Safety Code Division 13, Part 2.3 commencing with Section 18860 for special occupancy parks or the Department of Housing and Community Development.

Authority cited—Health and Safety Code Sections 18300 and 18865.

Reference—Health and Safety Code Sections 18200 through 18700 and 18860 through 18874.

SECTION 108.3 LOCAL ENFORCING AGENCY

108.3.1 Duties and powers. The building department of every city, county or city and county shall enforce all the provisions of law, this code, and the other rules and regulations promulgated by the Department of Housing and Community Development pertaining to the installation, erection, reconstruction, movement, enlargement, conversion, alteration, repair, removal, demolition or arrangement of apartment houses, hotels and dwellings, including accessory buildings, facilities and uses thereto.

The provisions regulating the erection and construction of dwellings and appurtenant structures shall not apply to existing structures as to which construction is commenced or approved prior to the effective date of these regulations. Requirements relating to use, maintenance and occupancy shall apply to all dwellings and appurtenant structures approved for construction or constructed before or after the effective date of this code.

108.3.2 Laws, rules and regulations. Other than the building standards contained in this code, and notwithstanding other provisions of law, the statutory authority and location of the laws, rules and regulations to be enforced by local enforcing agencies are listed by statute in Sections 108.3.2.1 through 108.3.2.5 below:

108.3.2.1 State Housing Law. Refer to the State Housing Law, California Health and Safety Code, Division 13, Part 1.5 commencing with Section 17910 and California Code of Regulations, Title 25, Division 1, Chapter 1, Subchapter 1, Article 1, commencing with Section 1, for the erection, reconstruction, movement, enlargement, conversion, alteration, repair, removal, demolition or arrangement of apartment houses, hotels and dwellings, including accessory buildings, facilities and uses thereto.

108.3.2.2 Mobilehome Parks Act. Refer to the Mobilehome Parks Act, California Health and Safety Code, Division 13, Part 2.1, Article 1, commencing with Section 18200 and California Code of Regulations, Title 25, Division 1, Chapter 2, commencing with Section 1000 for mobilehome park administrative and enforcement authority, permits, plans, fees, violations, inspections and penalties both within and outside mobilehome parks.

Exception: Mobilehome parks where the Department of Housing and Community Development is the enforcing agency.

108.3.2.3 Special Occupancy Parks Act. Refer to the Special Occupancy Parks Act, California Health and Safety Code, Division 13, Part 2.3, commencing with Section 18860 and California Code of Regulations, Title 25, Division 1, Chapter 2.2, Article 1, commencing with Section 2000 for special occupancy park administrative and enforcement authority, permits, fees, violations, inspections and penalties both within and outside of special occupancy parks.

Exception: Special occupancy parks where the Department of Housing and Community Development is the enforcing agency.

108.3.2.4 Employee Housing Act. Refer to the Employee Housing Act, California Health and Safety Code, Division 13, Part 1, commencing with Section 17000 and California Code of Regulations, Title 25, Division 1, Chapter 1, Subchapter 3, Article 1, commencing with Section 600 for employee housing administrative and enforcement authority, permits, fees, violations, inspections and penalties.

108.3.2.5 Factory-Built Housing Law. Refer to the Factory-Built Housing Law, California Health and Safety Code, Division 13, Part 6 commencing with Section 19960 and California Code of Regulations, Title 25, Division 1, Chapter 3, Subchapter 1, Article 1, commencing with Section 3000 for factory-built housing administrative and enforcement authority, permits, fees, violations, inspections and penalties.

SECTION 108.8 APPEALS BOARD

108.8.1 General. Every city, county or city and county shall establish a local appeals board and a housing appeals board. The local appeals board and housing appeals board shall each be comprised of at least five voting members that shall serve at the pleasure of the city, county or city and county. Appointments shall not be employees of the jurisdiction and shall consist of members who are qualified and specifically knowledgeable in the California Building Standards Codes and applicable local ordinances.

108.8.2 Definitions. The following terms shall for the purposes of this section have the meaning shown.

HOUSING APPEALS BOARD. The board or agency of a city, county or city and county which is authorized by the governing body of the city, county or city and county to hear appeals regarding the requirements of the city, county or city and county relating to the use, maintenance and change of occupancy of buildings and structures, including requirements governing alteration, additions, repair, demolition and moving. In any area in which there is no such board or agency, "Housing appeals board" means the local appeals board having jurisdiction over the area.

LOCAL APPEALS BOARD. The board or agency of a city, county or city and county which is authorized by the governing body of the city, county or city and county to hear appeals regarding the building requirements of the city, county or city and county. In any area in which there is no such board or agency, "Local appeals board" means the governing body of the city, county or city and county having jurisdiction over the area.

108.8.3 Appeals. Except as otherwise provided in law, any person, firm or corporation adversely affected by a decision, order or determination by a city, county or city and county relating to the application of building standards published in the California Building Standards Code, or any other applicable rule or regulation adopted by the Department of Housing and Community Development, or any lawfully enacted ordinance by a city, county or city and county, may appeal the issue for resolution to the local appeals board or housing appeals board as appropriate.

The local appeals board shall hear appeals relating to new building construction and the housing appeals board shall hear appeals relating to existing buildings.

SECTION 108.9 UNSAFE BUILDINGS OR STRUCTURES

108.9.1 Authority to enforce. Subject to other provisions of law, the administration, enforcement, actions, proceedings, abatement, violations and penalties for unsafe buildings and structures are contained in the following statutes and regulations:

1. For applications subject to the State Housing Law as referenced in Section 108.3.2.1 of this code, refer to Health and Safety Code Sections 17910 through 17995.5 and California Code of Regulations, Title 25, Division 1, Chapter 1, Subchapter 1.

2. For applications subject to the Mobilehome Parks Act as referenced in Section 108.3.2.2 of this code, refer to the Health and Safety Code, commencing with Section 18200, and California Code of Regulations, Title 25, Division 1, Chapter 2.
3. For applications subject to the Special Occupancy Parks Act as referenced in Section 108.3.2.3 of this code, refer to the Health and Safety Code, commencing with Section 18860, and California Code of Regulations, Title 25, Division 1, Chapter 2.
4. For applications subject to the Employee Housing Act as referenced in Section 108.3.2.4 of this code, refer to Health and Safety Code Sections 17000 through 17062.5 and California Code of Regulations, Title 25, Division 1, Chapter 1, Subchapter 3.
5. For applications subject to the Factory-Built Housing Law as referenced in Section 108.3.2.5 of this code, refer to Health and Safety Code Sections 19960 through 19997 and California Code of Regulations, Title 25, Division 1, Chapter 3, Subchapter 1.

108.9.2 Actions and proceedings. Subject to other provisions of law, punishments, penalties and fines for violations of building standards are contained in the following statutes and regulations:

1. For applications subject to the State Housing Law as referenced in Section 108.3.2.1 of this code, refer to Health and Safety Code Sections 17980 through 17995.5 and California Code of Regulations, Title 25, Division 1, Chapter 1, Subchapter 1.
2. For applications subject to the Mobilehome Parks Act as referenced in Section 108.3.2.2 of this code, refer to Health and Safety Code Sections 18200 through 18700 and California Code of Regulations, Title 25, Division 1, Chapter 2.
3. For applications subject to the Special Occupancy Parks Act as referenced in Section 108.3.2.3 of this code, refer to Health and Safety Code Sections 18866 through 18869 and California Code of Regulations, Title 25, Division 1, Chapter 2.
4. For applications subject to the Employee Housing Act as referenced in Section 108.3.2.4 of this code, refer to Health and Safety Code Sections 17060 through 17062.5 and California Code of Regulations, Title 25, Division 1, Chapter 1, Subchapter 3.
5. For applications subject to the Factory-Built Housing Law as referenced in Section 108.3.2.5 of this code, refer to Health and Safety Code Sections 19995 through 19997 and California Code of Regulations, Title 25, Division 1, Chapter 3, Subchapter 1.

SECTION 108.10 OTHER BUILDING REGULATIONS

108.10.1 Existing structures. Subject to the requirements of California Health and Safety Code Sections 17912, 17920.3, 17922(c), 17922.3, 17958.8 and 17958.9, the provisions contained in Chapter 34 relating to existing

structures shall only apply as identified in the Matrix Adoption Table under the authority of the Department of Housing and Community Development as listed in Sections 108.2.1.1 through 108.2.1.3 of this code.

108.10.2 Moved structures. Subject to the requirements of California Health and Safety Code Sections 17922.3 and 17958.9, the provisions contained in Chapter 34 relating to a moved residential structure shall only apply as identified in the Matrix Adoption Table under the authority of the Department of Housing and Community Development as listed in Sections 108.2.1.1 through 108.2.1.3 of this code.

SECTION 109 DIVISION OF THE STATE ARCHITECT

109.1 Division of the State Architect—Access Compliance.

General. The purpose of this code is to ensure that barrier-free design is incorporated in all buildings, facilities, site work and other improvements to which this code applies in compliance with state law to ensure that these improvements are accessible to and usable by persons with disabilities. Additions, alterations and structural repairs in all buildings and facilities shall comply with these provisions for new buildings, except as otherwise provided and specified herein.

The provisions of these regulations shall apply to any portable buildings leased or owned by a school district, and shall also apply to temporary and emergency buildings and facilities. Temporary buildings and facilities are not of permanent construction but are extensively used or are essential for public use for a period of time. Examples of temporary buildings or facilities covered include, but are not limited to: reviewing stands, temporary classrooms, bleacher areas, exhibit areas, temporary banking facilities, temporary health screening services or temporary safe pedestrian passageways around a construction site.

In addition, to incorporate standards at least as restrictive as those required by the federal government for barrier-free design under (1) Title III (Public Accommodations and Commercial Facilities), Subpart D (New Construction and Alteration) and Appendix A (Americans with Disabilities Act Standards for Accessible Design) (see 28 C.F.R., Part 36), and (2) Title II (Public Entities), Section 35.151 (New Construction and Alterations) (see 28 C.F.R., Part 35) both from the Americans with Disabilities Act of 1990, and (3) under the Fair Housing Amendments Act of 1988. Some of these regulations may be more stringent than state law in order to meet the federal requirement.

109.1.1 Application. See Government Code commencing with Section 4450.

Publicly funded buildings, structures, sidewalks, curbs and related facilities shall be accessible to and usable by persons with disabilities as follows:

109.1.1.1 All buildings, structures, sidewalks, curbs and related facilities constructed in the state by the use of state, county or municipal funds, or the funds of any political subdivision of the state.

109.1.1.2 All buildings, structures and facilities that are leased, rented, contracted, sublet or hired by any municipal, county or state division of government, or by a special district.

109.1.1.3 All publicly funded buildings used for congregate residences or for one- or two-family dwelling unit purposes shall conform to the provisions applicable to living accommodations.

109.1.1.4 All existing publicly funded buildings and facilities when alterations, structural repairs or additions are made to such buildings or facilities. For detailed requirements on existing buildings, see Chapter 11B, Division IV.

109.1.1.5 With respect to buildings, structures, sidewalks, curbs and related facilities not requiring a building permit, building standards published in the California Building Standards Code relating to access for persons with disabilities and other regulations adopted pursuant to Government Code Section 4450, and in effect at the time construction is commenced, shall be applicable.

109.1.2 Application. See Health and Safety Code commencing with Section 19952.

All privately funded public accommodations, as defined and commercial facilities, as defined, shall be accessible to persons with disabilities as follows:

Exception: Certain types of privately funded multistory buildings do not require installation of an elevator to provide access above and below the first floor. See Chapter 11B.

109.1.2.1 Any building, structure, facility, complex or improved area, or portions thereof, which are used by the general public.

109.1.2.2 Any sanitary facilities which are made available for the public, clients or employees in such accommodations or facilities.

109.1.2.3 Any curb or sidewalk intended for public use that is constructed in this state with private funds.

109.1.2.4 All existing privately funded public accommodations when alterations, structural repairs or additions are made to such public accommodations as set forth under Chapter 11B.

109.1.3 Application—Public housing and private housing available for public use. See Government Code Sections 4450 and 12955.1(d).

109.1.4 Enforcing agency.

109.1.4.1 The director of the Department of General Services where state funds are utilized for any project or where funds of counties, municipalities or other political subdivisions are utilized for the construction of elementary, secondary or community college projects.

109.1.4.2 The governing bodies where funds of counties, municipalities or other political subdivisions are utilized except as otherwise provided above.

LIFT, SPECIAL ACCESS. [DSA-AC & HCD 1-AC] See “Special access lift” Chapter 11A, Section 1107A.12-L, and Chapter 11B, Section 1102B.

LIGHT-DIFFUSING SYSTEM. See Section 2602.1.

LIGHT-FRAME CONSTRUCTION. A type of construction whose vertical and horizontal structural elements are primarily formed by a system of repetitive wood or light gage steel framing members.

LIGHT-TRANSMITTING PLASTIC ROOF PANELS. See Section 2602.1.

LIGHT-TRANSMITTING PLASTIC WALL PANELS. See Section 2602.1.

LIMIT STATE. See Section 1602.1.

[F] LIQUID. See Section 415.2.

[F] LIQUID STORAGE ROOM. See Section 415.2.

[F] LIQUID USE, DISPENSING AND MIXING ROOMS. See Section 415.2.

LISTED. See Section 902.1.

[HCD 1 & 2] “Listed” means all products that appear in a list published by an approved testing or listing agency. For additional information, see Health and Safety Code Section 17920(h).

For applications listed in Section 111 regulated by the Office of the State Fire Marshal, “Listed” shall also mean equipment or materials accepted by the State Fire Marshal as conforming to the provisions of the State Fire Marshal's regulations and which are included in a list published by the State Fire Marshal.

***LISTING AGENCY [HCD 1 & 2]** means an agency approved by the department that is in the business of listing and labeling products, materials, equipment and installations tested by an approved testing agency, and that maintains a periodic inspection program on current production of listed products, equipment and installations, and that, at least annually, makes available a published report of these listings. For additional information, see Health and Safety Code Section 17920(i).*

LIVE LOADS. See Section 1602.1.

LIVE LOADS (ROOF). See Section 1602.1.

LOAD AND RESISTANCE FACTOR DESIGN (LRFD). See Section 1602.1.

LOAD EFFECTS. See Section 1602.1.

LOAD FACTOR. See Section 1602.1.

LOADS. See Section 1602.1.

***LOBBY [HCD 1, HCD 2 & SFM]** is an area not defined as a waiting room at the entrance of a building through which persons must pass.*

***LODGING HOUSE [HCD 1]** is any building or portion thereof containing not more than five guest rooms where rent is paid in money, goods, labor or otherwise.*

LOT. A portion or parcel of land considered as a unit.

LOT LINE. A line dividing one lot from another, or from a street or any public place.

[F] LOWER FLAMMABLE LIMIT (LFL). See Section 415.2.

LOWEST FLOOR. See Section 1612.2.

MAIN WINDFORCE-RESISTING SYSTEM. See Section 1702.1.

MALL. See Section 402.2.

[F] MANUAL FIRE ALARM BOX. See Section 902.1.

MANUFACTURER'S DESIGNATION. See Section 1702.1.

MARK. See Section 1702.1.

***MARKED CROSSING. [DSA-AC & HCD 1-AC]** See Chapter 11A, Section 1107A.13-M, and Chapter 11B, Section 1102B.*

MARQUEE. A permanent roofed structure attached to and supported by the building and that projects into the public right-of-way.

MASONRY. See Section 2102.1.

Ashlar masonry. See Section 2102.1.

Coursed ashlar. See Section 2102.1.

Glass unit masonry. See Section 2102.1.

Plain masonry. See Section 2102.1.

Random ashlar. See Section 2102.1.

Reinforced masonry. See Section 2102.1.

Solid masonry. See Section 2102.1.

Unreinforced (plain) masonry. See Section 2102.1.

MASONRY UNIT. See Section 2102.1.

Clay. See Section 2102.1.

Concrete. See Section 2102.1.

Hollow. See Section 2102.1.

Solid. See Section 2102.1.

MAXIMUM CONSIDERED EARTHQUAKE GROUND MOTION. See Section 1613.2.

MEAN DAILY TEMPERATURE. See Section 2102.1.

MEANS OF EGRESS. See Section 1002.1.

MECHANICAL-ACCESS OPEN PARKING GARAGES. See Section 406.3.2.

MECHANICAL EQUIPMENT SCREEN. See Section 1502.1.

MECHANICAL SYSTEMS. See Section 1613.2.

MEMBRANE-COVERED CABLE STRUCTURE. See Section 3102.2.

MEMBRANE-COVERED FRAME STRUCTURE. See Section 3102.2.

MEMBRANE PENETRATION. See Section 702.1.

MEMBRANE-PENETRATION FIRESTOP. See Section 702.1.

DEFINITIONS

MENTALLY RETARDED PERSONS, PROFOUNDLY OR SEVERELY. See Section 310.

MERCHANDISE PAD. See Section 1002.1.

METAL COMPOSITE MATERIAL (MCM). See Section 1402.1.

METAL COMPOSITE MATERIAL (MCM) SYSTEM. See Section 1402.1.

METAL ROOF PANEL. See Section 1502.1.

METAL ROOF SHINGLE. See Section 1502.1.

MEZZANINE. See Section 502.1.

MICROPILES. See Section 1808.1.

MINERAL BOARD. See Section 721.1.1.

MINERAL FIBER. See Section 702.1.

MINERAL WOOL. See Section 702.1.

MODERNIZATION PROJECT [SFM] is any construction effort that has an estimated total cost in excess of \$200,000 that is intended to modify a permanent school building or structure and/or the addition of a new school building or structure used to serve or house students from kindergarten through 12th grade (K-12). Modernization efforts shall apply strictly to a public school that was established prior to July 1, 2002, and is funded pursuant to the Education Code, Section 17074.56, and Education Code commencing with Section 17070.10. Modernization projects that are to be completed in more than one phase may defer the installation of the automatic fire detection and alarm systems until the final phase of the modernization project. Solely for the purposes of Education Code Section 17074.20, routine maintenance and repair work shall not be considered a modernization project.

MODIFIED BITUMEN ROOF COVERING. See Section 1502.1.

MORTAR. See Section 2102.1.

MORTAR, SURFACE-BONDING. See Section 2102.1.

MOTEL. [DSA-AC, HCD 1 & HCD 2] See "Hotel or Motel."

MOTION PICTURE AND TELEVISION PRODUCTION STUDIO SOUND STAGES, APPROVED PRODUCTION FACILITIES AND PRODUCTION LOCATIONS. See Chapter 46, California Fire Code.

MULTILEVEL ASSEMBLY SEATING. See Section 1102.1.

MULTIPLE-ACCOMMODATION TOILET FACILITY [DSA-AC] is a room that has more than one sanitary fixture, is intended for the use of more than one person at a time and which usually is provided with privacy compartments or screens shielding some fixtures from view. A bathroom serving a hotel guest room and a privacy toilet in small offices, stores and similar locations are not included in this category.

[F] MULTIPLE-STATION ALARM DEVICE. See Section 902.1.

[F] MULTIPLE-STATION SMOKE ALARM. See Section 902.1.

MULTISTORY DWELLING UNIT. [DSA-AC & HCD 1-AC] See Chapter 11A, Section 1107A.13-M.

NAILING, BOUNDARY. See Section 2302.1.

NAILING, EDGE. See Section 2302.1.

NAILING, FIELD. See Section 2302.1.

NATURALLY DURABLE WOOD. See Section 2302.1.

Decay resistant. See Section 2302.1.

Termite resistant. See Section 2302.1.

NEWLY CONSTRUCTED. [DSA-AC & HCD 1-AC] See Chapter 11A, Section 1107A.14-N.

NEW PUBLIC SCHOOL CAMPUS [SFM] is an educational institution established on or after July 1, 2002 that houses and/or serves students from kindergarten through 12th grade (K-12) and is funded pursuant to the Education Code, commencing with Section 17070.10.

NFPA [DSA-AC] is the National Fire Protection Association.

NONAMBULATORY PERSONS. See Section 310.

NONCOMBUSTIBLE, [SFM] as applied to building construction material, means a material which, in the form in which it is used, is either one of the following:

1. Material of which no part will ignite and burn when subjected to fire. Any material passing ASTM E 136 shall be considered noncombustible. ||
2. Material having a structural base of noncombustible material as defined in Item 1 above, with a surfacing material not over 1/8 inch (3.2 mm) thick which has a flame-spread rating of 50 or less.

"Noncombustible" does not apply to surface finish materials. Material required to be noncombustible for reduced clearances to flues, heating appliances or other sources of high temperature shall refer to material conforming to Item 1. No material shall be classed as noncombustible, which is subject to increase in combustibility or flame spread rating, beyond the limits herein established, through the effects of age, moisture or other atmospheric condition.

NOMINAL LOADS. See Section 1602.1.

NOMINAL SIZE. (LUMBER). See Section 2302.1.

NONCOMBUSTIBLE MEMBRANE STRUCTURE. See Section 3102.2.

NORMAL [HCD 1 & HCD 2] shall mean conforming to a pattern or standard regarded as usual or typical.

[F] NORMAL TEMPERATURE AND PRESSURE (NTP). See Section 415.2.

NOSING (or NOSE). See Section 1002.1. [DSA-AC & HCD 1-AC] See Chapter 11A, Section 1107A.14-N and Chapter 11B, Section 1102B.

[F] NUISANCE ALARM. See Section 902.1.

OCCUPANCY CATEGORY. See Section 1602.1.

OCCUPANT LOAD. See Section 1002.1.

OCCUPIABLE SPACE. A room or enclosed space designed for human occupancy in which individuals congregate for

SPECIAL ACCESS LIFT. [DSA-AC & HCD-IAC] See Chapter 11A, Section 1107A.19-S, and Chapter 11B, Section 1102B.

SPECIAL AMUSEMENT BUILDING. See Section 411.2.

SPECIAL INSPECTION. See Section 1702.1.

Special inspection, continuous. See Section 1702.1.

Special inspection, periodic. See Section 1702.1.

SPECIAL FLOOD HAZARD AREA. See Section 1612.2.

SPECIFIED. See Section 2102.1.

SPECIFIED COMPRESSIVE STRENGTH OF MASONRY (f'_m). See Section 2102.1.

SPECIFIED PUBLIC TRANSPORTATION. [DSA-AC] See Chapter 11B, Section 1102B.

SPLICE. See Section 702.1.

SPRAYED FIRE-RESISTANT MATERIALS. See Section 1702.1.

STACK BOND. See Section 2102.1.

STAGE. See Section 410.2.

STAIR. See Section 1002.1.

STAIRWAY. See Section 1002.1.

STAIRWAY, EXTERIOR. See Section 1002.1.

STAIRWAY, INTERIOR. See Section 1002.1.

STAIRWAY, SPIRAL. See Section 1002.1.

[F] STANDPIPE SYSTEM, CLASSES OF. See Section 902.1.

Class I system. See Section 902.1.

Class II system. See Section 902.1.

Class III system. See Section 902.1.

[F] STANDPIPE, TYPES OF. See Section 902.1.

Automatic dry. See Section 902.1.

Automatic wet. See Section 902.1.

Manual dry. See Section 902.1.

Manual wet. See Section 902.1.

Semiautomatic dry. See Section 902.1.

START OF CONSTRUCTION. See Section 1612.2.

STATE-OWNED/LEASED BUILDING [SFM] is a building or portion of a building that is owned, leased or rented by the state. State-leased buildings shall include all required exits to a public way serving such leased area or space. Portions of state-leased buildings that are not leased or rented by the state shall not be included within the scope of this section unless such portions present an exposure hazard to the state-leased area or space.

STEEL CONSTRUCTION, COLD-FORMED. See Section 2202.1.

STEEL JOIST. See Section 2202.1.

STEEL MEMBER, STRUCTURAL. See Section 2202.1.

STEEP SLOPE. A roof slope greater than two units vertical in 12 units horizontal (17-percent slope).

STONE MASONRY. See Section 2102.1.

Ashlar stone masonry. See Section 2102.1.

Rubble stone masonry. See Section 2102.1.

[F] STORAGE, HAZARDOUS MATERIALS. See Section 415.2.

STORY. The portion of a building included between the upper surface of a floor and the upper surface of the floor or roof next above (also see “Mezzanine” and Section 502.1). It is measured as the vertical distance from top to top of two successive tiers of beams or finished floor surfaces and, for the topmost story, from the top of the floor finish to the top of the ceiling joists, or where there is not a ceiling, to the top of the roof rafters.

[DSA-AC] See Chapter 11B, Section 1102B.

STORY ABOVE GRADE PLANE. Any story having its finished floor surface entirely above grade plane, except that a basement shall be considered as a story above grade plane where the finished surface of the floor above the basement is:

1. More than 6 feet (1829 mm) above grade plane; or
2. More than 12 feet (3658 mm) above the finished ground level at any point.

STORY, FIRST. [DSA-AC] See Chapter 11B, Section 1102B.

STRENGTH. See Section 2102.1.

Design strength. See Section 2102.1.

Nominal strength. See Sections 1602.1 and 2102.1.

Required strength. See Sections 1602.1 and 2102.1.

STRENGTH DESIGN. See Section 1602.1.

STRUCTURAL COMPOSITE LUMBER. See Section 2302.1.

Laminated veneer lumber (LVL). See Section 2302.1.

Parallel strand lumber (PSL). See Section 2302.1.

STRUCTURAL FRAME. [DSA-AC] See Chapter 11B, Section 1102B.

STRUCTURAL GLUED-LAMINATED TIMBER. See Section 2302.1.

STRUCTURAL OBSERVATION. See Section 1702.1.

STRUCTURE. That which is built or constructed.

SUBDIAPHRAGM. See Section 2302.1.

SUBSTANTIAL DAMAGE. See Section 1612.2.

SUBSTANTIAL IMPROVEMENT. See Section 1612.2.

SUNROOM ADDITION. See Section 1202.1.

[F] SUPERVISING STATION. See Section 902.1.

[F] SUPERVISORY SERVICE. See Section 902.1.

[F] SUPERVISORY SIGNAL. See Section 902.1.

[F] SUPERVISORY SIGNAL-INITIATING DEVICE. See Section 902.1.

DEFINITIONS

SWIMMING POOLS. See Section 3109.2.

T RATING. See Section 702.1.

TACTILE [DSA-AC & HCD 2] describes an object that can be perceived using the sense of touch.

TECHNICALLY INFEASIBLE. See Section 3402.

[DSA-AC] “Technically infeasible” means, with respect to an alteration of a building or a facility, that it has little likelihood of being accomplished because existing structural conditions would require removing or altering a load-bearing member which is an essential part of the structural frame; or because other existing physical or site constraints prohibit modification or addition of elements, spaces or features which are in full and strict compliance with the minimum requirements for new construction and which are necessary to provide accessibility.

TEMPORARY [DSA-AC] shall mean buildings and facilities intended for use at one location for not more than one year and seats intended for use at one location for not more than 90 days.

TENT. Any structure, enclosure or shelter which is constructed of canvas or pliable material supported in any manner except by air or the contents it protects.

TERMINALLY ILL. See Section 310.

TESTING AGENCY [HCD-1 & HCD- 2] means an agency approved by the department as qualified and equipped for testing products, materials, equipment and installations in accordance with nationally recognized standards. For additional information, see Health and Safety Code Section 17920(m).

TEXT TELEPHONE. [DSA-AC] See Chapter 11B, Section 1102B.

THERMAL ISOLATION. See Section 1202.1.

THERMOPLASTIC MATERIAL. See Section 2602.1.

THERMOSETTING MATERIAL. See Section 2602.1.

THIN-BED MORTAR. See Section 2102.1.

THROUGH PENETRATION. See Section 702.1.

THROUGH-PENETRATION FIRESTOP SYSTEM. See Section 702.1.

TIE-DOWN (HOLD-DOWN). See Section 2302.1.

TIE, LATERAL. See Section 2102.1.

TIE, WALL. See Section 2102.1.

TILE. See Section 2102.1.

TILE, STRUCTURAL CLAY. See Section 2102.1.

[F] TIRES, BULK STORAGE OF. See Section 902.1.

TOEBOARD. [DSA-AC & HCD 1-AC] See Chapter 11A, Section 1107A.20-T.

TOWNHOUSE. A single-family dwelling unit constructed in a group of three or more attached units in which each unit

extends from the foundation to roof and with open space on at least two sides.

[DSA-AC & HCD 1-AC] For applications required to provide accommodations for persons with disabilities, see Chapter 11A, Section 1107A.20-T.

[F] TOXIC. See Section 307.2.

TRANSIENT. See Section 310.2.

TRANSIENT LODGING. [DSA-AC & HCD 1-AC] See Chapter 11B, Section 1102B and Chapter 11A, Section 1107A.20-T.

TRANSIT BOARDING PLATFORM. [DSA-AC] See Chapter 11B, Section 1102B.

TREAD. [DSA-AC & HCD 1-AC] See Chapter 11A, Section 1107A.20-T, and Chapter 11B, Section 1102B.

TREAD DEPTH. [DSA-AC & HCD 1-AC] See Chapter 11A, Section 1107A.20-T, and Chapter 11B, Section 1102B.

TREAD RUN. [DSA-AC & HCD 1-AC] See Chapter 11A, Section 1107A.20-T, and Chapter 11B, Section 1102B.

TREATED WOOD. See Section 2302.1.

TRIM. See Section 802.1.

[F] TROUBLE SIGNAL. See Section 902.1.

TYPE OF MOTOR FUEL. [DSA-AC] See Chapter 11C, Section 1101C.1.

UNDERLAYMENT. See Section 1502.1.

UNREASONABLE HARDSHIP [DSA-AC] exists when the enforcing agency finds that compliance with the building standard would make the specific work of the project affected by the building standard unfeasible, based on an overall evaluation of the following factors:

1. The cost of providing access.
2. The cost of all construction contemplated.
3. The impact of proposed improvements on financial feasibility of the project.
4. The nature of the accessibility which would be gained or lost.
5. The nature of the use of the facility under construction and its availability to persons with disabilities.

The details of any finding of unreasonable hardship shall be recorded and entered in the files of the enforcing agency.

[F] UNSTABLE (REACTIVE) MATERIAL. See Section 307.2.

Class 4. See Section 307.2.

Class 3. See Section 307.2.

Class 2. See Section 307.2.

Class 1. See Section 307.2.

[F] USE (MATERIAL). See Section 415.2.

425.8.5 Changes in level. In Group R-3.1 occupancies housing nonambulatory clients, changes in level up to 0.25 inch (6 mm) may be vertical and without edge treatment. Changes in level between 0.25 inch (6 mm) and 0.5 inch (12.7 mm) shall be beveled with a slope no greater than 1 unit vertical in 2 units horizontal (50 percent slope). Changes in level greater than 0.5 inch (12.7 mm) shall be accomplished by means of a ramp.

425.8.6 Stairways.

425.8.6.1 Group I-1 and R-4 occupancies housing more than six nonambulatory clients above the first floor shall be provided with two vertical exit enclosures. Stairway enclosures shall be in compliance with Section 1020. Exceptions to Section 1020 shall not apply in facilities licensed as a 24-hour care facility.

425.8.6.2 Group R-3.1 occupancies may continue to use existing stairways (except for winding and spiral stairways which are not permitted as a required means of egress) provided the stairs have a maximum rise of 8 inches (203 mm) with a minimum run of 9 inches (229 mm). The minimum stairway width may be 30 inches (762 mm).

425.8.7 Floor separation. Group R-3.1 occupancies shall be provided with a nonfire resistance constructed floor separation at stairs which will prevent smoke migration between floors. Such floor separation shall have equivalent construction of 0.5 inch (12.7 mm) gypsum wallboard on one side of wall framing.

Exceptions:

1. Occupancies with at least one exterior exit from floors occupied by clients.
2. Occupancies provided with automatic fire sprinkler systems complying with Chapter 9.

425.8.7.1 Doors within floor separations. Doors within such floor separations shall be tight fitting solid wood at least $1\frac{3}{8}$ inches (35 mm) in thickness. Door glazing shall not exceed 1,296 inches (32 918 mm) with no dimension greater than 54 inches (1372 mm). Such doors shall be positive latching, smoke gasketed and shall be automatic-closing by smoke detection.

425.8.8 Fences and gates. Grounds of a residential care for the elderly facility serving Alzheimer's clients may be fenced and gates therein equipped with locks, provided safe dispersal areas are located not less than 50 feet (15 240 mm) from the buildings. Dispersal areas shall be sized to provide an area of not less than 3 square feet (0.28²) per occupant. Gates shall not be installed across corridors or passageways leading to such dispersal areas unless they comply with egress requirements.

425.8.9 Basement exits. One exit is required to grade level when the basement is accessible to clients.

425.8.10 Delayed egress locks. See Section 1008.1.8.6.

425.9 Request for alternate means of protection for facilities housing bedridden clients. Request for alternate means of protection shall apply to Sections 425 through 425.9. Request for approval to use an alternative material, assembly or materials,

equipment, method of construction, method of installation of equipment or means of protection shall be made in writing to the local fire authority having jurisdiction by the facility, client or the client's authorized representative. Sufficient evidence shall be submitted to substantiate the need for an alternate means of protection.

The facility, client or the client's representative or the local fire authority having jurisdiction may request a written opinion from the State Fire Marshal concerning the interpretation of the regulations promulgated by the State Fire Marshal for a particular factual dispute. The State Fire Marshal shall issue the written opinion within 45 days following the request.

Approval of a request for use of an alternative material, assembly or materials, equipment, method of construction, method of installation of equipment, or means of protection made pursuant to this section shall be limited to Group R-3.1 occupancies housing a bedridden client.

Approvals made by the local fire authority having jurisdiction and the written opinion by the State Fire Marshal shall be applicable only to the requesting facility and shall not be construed as establishing any precedent for any future request by that facility or any other facility.

SECTION 426 GROUP I-4 [SFM]

426.1 Group I-4 special provisions. Rooms classified as Group I-4 shall not be located above or below the first story.

Exceptions:

1. Basements or stories having floor levels located within 4 feet (1219 mm), measured vertically, from adjacent ground level at the level of exit discharge, provided the basement or story has exterior exit doors at that level.
2. In buildings equipped with an automatic sprinkler system throughout, rooms used for day-care purposes may be located on the second story, provided there are at least two exterior exit doors for the exclusive use of such occupants
3. Group I-4 child care facilities may be located above the first story in buildings of Type I construction and in Types IIa, and IIIa construction, subject to the limitation of Section 503 when:
 - 3.1. Group I-4 child care facilities with children under the age of seven or containing more than 12 children per story shall not be located above the fourth floor; and
 - 3.2. The entire story in which the Group I-4 child care facility is located is equipped with an approved manual fire alarm and smoke detection system (see the California Fire Code). Actuation of an initiating device shall sound an audible alarm throughout the entire story.

When a building fire alarm system is required by other provisions of this code or the California Fire Code, the alarm system shall be connected to the building alarm system. An

approved alarm signal shall sound at an approved location in the Group I-4 child care facility to indicate a fire alarm or sprinkler flow condition in other portions of the building; and

- 3.3. Group I-4 child care facilities, if more than 1,000 square feet (92.9 m²) in area, is divided into at least two compartments of approximately the same size by a smoke barrier with door openings protected by smoke- and draft-control assemblies having a fire protection rating of not less than 20 minutes. Smoke barriers shall have a fire-resistive rating of not less than 1 hour. In addition to the requirements of Section 508.3.3, occupancy separations between Group I-4 child care and other occupancies shall be constructed as smoke barriers. Door openings in the smoke barrier shall be tightfitting, with gaskets installed as required by Section 709, and shall be automatic closing by actuation of the automatic sprinklers, fire alarm or smoke detection system; and
- 3.4. Each compartment formed by the smoke barrier has not less than two exits or exit access doors, one of which is permitted to pass through the adjoining compartment; and
- 3.5. Where two or more means of exits or exit access are required at least one shall not share a common path of travel; and
- 3.6. The building is equipped with an automatic sprinkler system throughout.

SECTION 427 **Reserved**

SECTION 428 **Reserved**

SECTION 429 **Reserved**

SECTION 430 **HORSE RACING STABLES [SFM]**

430.1 For automatic sprinkler and fire alarm system requirements applying to each building, barn or structure which is used by an association regulated by the California Horse Racing Board for the stabling of horses or human habitation, and the stable area grounds, including any additional location where any excess horses are stabled, see Title 4, Division 4, Article 17, Section 1927.

SECTION 431 **PET KENNELS [SFM]**

431.1 These regulations shall apply to every building or fire area in which a pet dealer, as defined in Health and Safety Code Section 122125, maintains a kennel.

431.2 Automatic sprinkler system. An approved automatic sprinkler system complying with California Fire Code Section 903 shall be installed.

Exception: Where a fire alarm system that is connected to a central reporting station that alerts the local fire department in case of fire.

SECTION 432 **COMBUSTION ENGINES AND GAS TURBINES [SFM]**

432.1 General. The installation of combustion engines and gas turbines shall be in accordance with NFPA 37 and this chapter.

432.2 Separation.

432.2.1 Construction. Every room in which is installed a combustion engine or gas turbine shall be separated from the remainder of the building by not less than a 1-hour fire barrier.

432.2.2 Exterior openings. When doors, windows or louvered openings are located below openings in another story or less than 10 feet (3048 mm) from doors, windows or louvered openings of the same building, they shall be protected by a fire assembly having a ³/₄-hour rating. Such fire assemblies shall be fixed, automatic or self-closing.

432.2.2.1 Interior openings. In other than buildings housing Group I occupancies, interior openings shall be allowed in buildings protected by an automatic fire sprinkler system throughout.

432.2.3 Location. Combustion engines and gas turbines used for emergency power shall not be located in a room or area used for any purpose other than equipment and controls related to the generation and distribution of emergency power.

432.2.4 Special hazards. The handling and use of flammable or combustible liquids shall comply with the California Fire Code.

SECTION 433 **FIXED GUIDEWAY TRANSIT SYSTEMS [SFM]**

433.1 General.

433.1.1 Scope. The provisions of this section shall apply to buildings or structures defined as stations for fixed guideway transit systems and shall supersede other similar requirements in other sections of this code.

433.1.2 Definitions. For the purpose of this section, certain terms are defined as follows:

AT-GRADE STATION is any at-grade or unroofed station other than an elevated or underground station.

CHAPTER 5

GENERAL BUILDING HEIGHTS AND AREAS

SECTION 501 GENERAL

501.1 Scope. The provisions of this chapter control the height and area of structures hereafter erected and additions to existing structures.

[F] 501.2 Address numbers. Buildings shall have approved address numbers, building numbers or approved building identification placed in a position that is plainly legible and visible from the street or road fronting the property. These numbers shall contrast with their background. Address numbers shall be Arabic numerals or alphabetical letters. Numbers shall be a minimum of 4 inches (102 mm) high with a minimum stroke width of 0.5 inch (12.7 mm).

SECTION 502 DEFINITIONS

502.1 Definitions. The following words and terms shall, for the purposes of this chapter and as used elsewhere in this code, have the meanings shown herein.

AREA, BUILDING. The area included within surrounding exterior walls (or exterior walls and fire walls) exclusive of vent shafts and courts. Areas of the building not provided with surrounding walls shall be included in the building area if such areas are included within the horizontal projection of the roof or floor above.

BASEMENT. That portion of a building that is partly or completely below grade plane (see “Story above grade plane” in Section 202). A basement shall be considered as a story above grade plane where the finished surface of the floor above the basement is:

1. More than 6 feet (1829 mm) above grade plane; or
2. More than 12 feet (3658 mm) above the finished ground level at any point.

EQUIPMENT PLATFORM. An unoccupied, elevated platform used exclusively for mechanical systems or industrial process equipment, including the associated elevated walkways, stairs and ladders necessary to access the platform (see Section 505.5).

GRADE PLANE. A reference plane representing the average of finished ground level adjoining the building at exterior walls. Where the finished ground level slopes away from the exterior walls, the reference plane shall be established by the lowest points within the area between the building and the lot line or, where the lot line is more than 6 feet (1829 mm) from the building, between the building and a point 6 feet (1829 mm) from the building.

[HCD 1 & HCD 2] “Grade or grade plane” is the lowest point of elevation of the finished surface of the ground, paving or sidewalk within the area between the building and the property line or, when the property line is more than 5 feet

(1524 mm) from the building, between the building and a line 5 feet (1524 mm) from the building. For additional information, see Health and Safety Code, Section 19955.3 (d).

HEIGHT, BUILDING. The vertical distance from grade plane to the average height of the highest roof surface.

HEIGHT, STORY. The vertical distance from top to top of two successive finished floor surfaces; and, for the topmost story, from the top of the floor finish to the top of the ceiling joists or, where there is not a ceiling, to the top of the roof rafters.

MEZZANINE. An intermediate level or levels between the floor and ceiling of any story and in accordance with Section 505.

SECTION 503 GENERAL HEIGHT AND AREA LIMITATIONS

503.1 General. The height and area for buildings of different construction types shall be governed by the intended use of the building and shall not exceed the limits in Table 503 except as modified hereafter. Each part of a building included within the exterior walls or the exterior walls and fire walls where provided shall be permitted to be a separate building.

Exception: [HCD 1] Limited-density owner-built rural dwellings may be of any type of construction which will provide for a sound structural condition. Structural hazards which result in an unsound condition and which may constitute a substandard building are delineated by Section 17920.3 of the Health and Safety Code.

503.1.1 Special industrial occupancies. Buildings and structures designed to house special industrial processes that require large areas and unusual heights to accommodate craneways or special machinery and equipment, including, among others, rolling mills; structural metal fabrication shops and foundries; or the production and distribution of electric, gas or steam power, shall be exempt from the height and area limitations of Table 503.

503.1.2 Buildings on same lot. Two or more buildings on the same lot shall be regulated as separate buildings or shall be considered as portions of one building if the height of each building and the aggregate area of buildings are within the limitations of Table 503 as modified by Sections 504 and 506. The provisions of this code applicable to the aggregate building shall be applicable to each building.

503.1.3 Type I construction. Buildings of Type I construction permitted to be of unlimited tabular heights and areas are not subject to the special requirements that allow unlimited area buildings in Section 507 or unlimited height in Sections 503.1.1 and 504.3 or increased height and areas for other types of construction.

TABLE 503
ALLOWABLE HEIGHT AND BUILDING AREAS³
 Height limitations shown as stories and feet above grade plane.
 Area limitations as determined by the definition of "Area, building," per story

GROUP	HGT(S)	TYPE OF CONSTRUCTION								
		TYPE I		TYPE II		TYPE III		TYPE IV	TYPE V	
		A	B	A	B	A	B	HT	A	B
	HGT(feet)									
		UL	160	65	55	65	55	65	50	40
A-1	S A	UL UL	5 UL	3 15,500	2 8,500	3 14,000	2 8,500	3 15,000	2 11,500	1 5,500
A-2	S A	UL UL	11 UL	3 15,500	2 9,500	3 14,000	2 9,500	3 15,000	2 11,500	1 6,000
A-3	S A	UL UL	11 UL	3 15,500	2 9,500	3 14,000	2 9,500	3 15,000	2 11,500	1 6,000
A-4	S A	UL UL	11 UL	3 15,500	2 9,500	3 14,000	2 9,500	3 15,000	2 11,500	1 6,000
A-5	S A	UL UL	UL UL	UL UL	UL UL	UL UL	UL UL	UL UL	UL UL	UL UL
B	S A	UL UL	11 UL	5 37,500	4 23,000	5 28,500	4 19,000	5 36,000	3 18,000	2 9,000
E	S A	UL UL	5 UL	3 26,500	2 14,500	3 23,500	2 14,500	3 25,500	1 18,500	1 9,500
F-1	S A	UL UL	11 UL	4 25,000	2 15,500	3 19,000	2 12,000	4 33,500	2 14,000	1 8,500
F-2	S A	UL UL	11 UL	5 37,500	3 23,000	4 28,500	3 18,000	5 50,500	3 21,000	2 13,000
H-1	S A	1 21,000	1 16,500	1 11,000	1 7,000	1 9,500	1 7,000	1 10,500	1 7,500	NP NP
H-2 ^d	S A	UL 21,000	3 16,500	2 11,000	1 7,000	2 9,500	1 7,000	2 10,500	1 7,500	1 3,000
H-3 ^d	S A	UL UL	6 60,000	4 26,500	2 14,000	4 17,500	2 13,000	4 25,500	2 10,000	1 5,000
H-4	S A	UL UL	7 UL	5 37,500	3 17,500	5 28,500	3 17,500	5 36,000	3 18,000	2 6,500
H-5	S A	4 UL	4 UL	3 37,500	3 23,000	3 28,500	3 19,000	3 36,000	3 18,000	2 9,000
I-1	S A	UL UL	9 55,000	4 19,000	3 10,000	4 16,500	3 10,000	4 18,000	3 10,500	2 4,500
I-2/I-2.1	S A	UL UL	4 UL	2 15,000	1 11,000	1 12,000	NP NP	1 12,000	1 9,500	NP NP
I-3 ^e	S A	UL UL	2 15,100	NP NP	NP NP	NP NP	NP NP	NP NP	NP NP	NP NP
I-4	S A	UL UL	5 60,500	3 26,500	2 13,000	3 23,500	2 13,000	3 25,500	1 18,500	1 9,000
L	S A	10 UL	3 39,900	3 18,000	2 12,000	3 18,000	2 12,000	3 18,000	3 14,000	1 8,000
M	S A	UL UL	11 UL	4 21,500	4 12,500	4 18,500	4 12,500	4 20,500	3 14,000	1 9,000
R-1	S A	UL UL	11 UL	4 24,000	4 16,000	4 24,000	4 16,000	4 20,500	3 12,000	2 7,000
R-2	S A	UL UL	11 UL	4 24,000	4 16,000	4 24,000	4 16,000	4 20,500	3 12,000	2 7,000
R-3/R-3.1	S A	UL UL	11 UL	4 UL	4 UL	4 UL	4 UL	4 UL	3 UL	3 UL
R-4	S A	UL UL	11 UL	4 24,000	4 16,000	4 24,000	4 16,000	4 20,500	3 12,000	2 7,000
S-1	S A	UL UL	11 48,000	4 26,000	3 17,500	3 26,000	3 17,500	4 25,500	3 14,000	1 9,000
S-2 ^{b,c}	S A	UL UL	11 79,000	5 39,000	4 26,000	4 39,000	4 26,000	5 38,500	4 21,000	2 13,500

(continued)

- F* = Building perimeter that fronts on a public way or open space having 20 feet (6096 mm) open minimum width (feet).
- P* = Perimeter of entire building (feet).
- W* = Width of public way or open space (feet) in accordance with Section 506.2.1.

506.2.1 Width limits. “*W*” must be at least 20 feet (6096 mm). Where the value of *W* varies along the perimeter of the building, the calculation performed in accordance with Equation 5-2 shall be based on the weighted average of each portion of exterior wall and open space where the value of *W* is greater than or equal to 20 feet (6096 mm). Where *W* exceeds 30 feet (9144 mm), a value of 30 feet (9144 mm) shall be used in calculating the weighted average, regardless of the actual width of the open space.

Exception: The quantity of *W* divided by 30 shall be permitted to be a maximum of 2 when the building meets all requirements of Section 507 except for compliance with the 60-foot (18 288 mm) public way or yard requirement, as applicable.

506.2.2 Open space limits. Such open space shall be either on the same lot or dedicated for public use and shall be accessed from a street or approved fire lane.

506.3 Automatic sprinkler system increase. Where a building is equipped throughout with an approved automatic sprinkler system in accordance with Section 903.3.1.1, the area limitation in Table 503 is permitted to be increased by an additional 200 percent ($I_s = 2$) for buildings with more than one story above grade plane and an additional 300 percent ($I_s = 3$) for buildings with no more than one story above grade plane. *In other than high-rise buildings, Group A, E, H, I, L and R occupancies or other applications listed in Section 111 regulated by the Office of the State Fire Marshal, these increases are permitted in addition to the height and story increases in accordance with Section 504.2. For Group R-2 buildings of Type VA construction equipped throughout with an approved automatic sprinkler system in accordance with Section 903.3.1.1, these increases are permitted in addition to the height increase in accordance with Section 504.2.*

Exception: The area limitation increases shall not be permitted for the following conditions:

1. The automatic sprinkler system increase shall not apply to buildings with an occupancy in Use Group H-1.
2. The automatic sprinkler system increase shall not apply to the floor area of an occupancy in Use Group H-2 or H-3. For mixed-use buildings containing such occupancies, the allowable area shall be calculated in accordance with Section 508.3.3.2, with the sprinkler increase applicable only to the portions of the building not classified as Use Group H-2 or H-3.
3. Fire-resistance rating substitution in accordance with Table 601, Note e.
4. [SFM] The automatic sprinkler system increase shall not apply to Group L occupancies.

506.4 Area determination. *In other than high-rise buildings, Group A, E, H, I, L and R occupancies and other applications*

listed in Section 111 regulated by the Office of the State Fire Marshal, the maximum area of a building with more than one story above grade plane shall be determined by multiplying the allowable area of the first story (A_a), as determined in Section 506.1, by the number of stories above grade plane as listed below:

1. For buildings with two stories above grade plane, multiply by 2;
2. For buildings with three or more stories above grade plane, multiply by 3; and
3. No story shall exceed the allowable area per story (A_a), as determined in Section 506.1, for the occupancies on that story.

Exception:

1. Unlimited area buildings in accordance with Section 507.

For high-rise buildings, Group A, E, H, I, L and R occupancies and other applications listed in Section 111 regulated by the Office of the State Fire Marshal, the maximum area of a building with more than one story above grade plane shall be determined by multiplying the allowable area of the first story (A_a), as determined in Section 506.1, by the number of stories above grade plane as listed below:

1. For buildings with two or more stories above grade plane, multiply by 2;
2. No story shall exceed the allowable area per story (A_a), as determined in Section 506.1, for the occupancies on that story.

Exception: Unlimited area buildings in accordance with Section 507.

506.4.1 Mixed occupancies. In buildings with mixed occupancies, the allowable area per story (A_a) shall be based on the most restrictive provisions for each occupancy when the mixed occupancies are treated according to Section 508.3.2. When the occupancies are treated according to Section 508.3.3 as separated occupancies, the maximum total building area shall be such that the sum of the ratios for each such area on all floors as calculated according to Section 508.3.3.2 shall *comply with the following:*

1. For other than high-rise buildings, Group A, E, H, I, L, and R occupancies and other applications listed in Section 111 regulated by the Office of the State Fire Marshal, the sum shall not exceed 2 for two-story buildings and 3 for buildings three stories or higher.
2. For high-rise buildings, Group A, E, H, I, L, and R occupancies and other applications listed in Section 111 regulated by the Office of the State Fire Marshal, the sum shall not exceed 2 for buildings two stories or higher.

**SECTION 507
UNLIMITED AREA BUILDINGS**

507.1 General. The area of buildings of the occupancies and configurations specified herein shall not be limited.

507.2 Nonsprinklered, one story. The area of a one-story, Group F-2 or S-2 building shall not be limited when the building is surrounded and adjoined by public ways or yards not less than 60 feet (18 288 mm) in width.

507.3 Sprinklered, one story. The area of a one-story, Group B, F, M or S building, shall not be limited when the building is provided with an automatic sprinkler system throughout in accordance with Section 903.3.1.1 and is surrounded and adjoined by public ways or yards not less than 60 feet (18 288 mm) in width.

Exceptions:

1. Buildings and structures of Type I and II construction for rack storage facilities that do not have access by the public shall not be limited in height, provided that such buildings conform to the requirements of Sections 507.2 and 903.3.1.1 and NFPA 230.
2. Group A-1 and A-2 occupancies of other than Type V construction shall be permitted, provided:
 - 2.1. All assembly occupancies are separated from other spaces as required for separated uses in Section 508.3.3.4 with no reduction allowed in the fire-resistance rating of the separation based upon the installation of an automatic sprinkler system;
 - 2.2. Each Group A occupancy shall not exceed the maximum allowable area permitted in Section 503.1; and
 - 2.3. All required exits shall discharge directly to the exterior.

507.4 Two story. The area of a two-story, Group B, F, M or S building shall not be limited when the building is equipped throughout with an automatic sprinkler system in accordance with Section 903.3.1.1, and is surrounded and adjoined by public ways or yards not less than 60 feet (18 288 mm) in width.

507.5 Reduced open space. The permanent open space of 60 feet (18 288 mm) required in Sections 507.2, 507.3, 507.4, 507.6 and 507.10 shall be permitted to be reduced to not less than 40 feet (12 192 mm), provided the following requirements are met:

1. The reduced open space shall not be allowed for more than 75 percent of the perimeter of the building.
2. The exterior wall facing the reduced open space shall have a minimum fire-resistance rating of 3 hours.
3. Openings in the exterior wall facing the reduced open space shall have opening protectives with a minimum fire protection rating of 3 hours.

507.6 Group A-3 buildings. The area of a one-story, Group A-3 building used as a place of religious worship, community hall, dance hall, exhibition hall, gymnasium, lecture hall, indoor swimming pool or tennis court of Type II construction shall not be limited when all of the following criteria are met:

1. The building shall not have a stage other than a platform.

2. The building shall be equipped throughout with an automatic sprinkler system in accordance with Section 903.3.1.1.
3. The assembly floor shall be located at or within 21 inches (533 mm) of street or grade level and all exits are provided with ramps complying with Section 1010.1 to the street or grade level.
4. The building shall be surrounded and adjoined by public ways or yards not less than 60 feet (18 288 mm) in width.

507.7 Group H occupancies. Group H-2, H-3 and H-4 occupancies shall be permitted in unlimited area buildings containing Group F and S occupancies, in accordance with Sections 507.3 and 507.4 and the limitations of this section. The aggregate floor area of the Group H occupancies located at the perimeter of the unlimited area building shall not exceed 10 percent of the area of the building nor the area limitations for the Group H occupancies as specified in Table 503 as modified by Section 506.2, based upon the percentage of the perimeter of each Group H fire area that fronts on a street or other unoccupied space. The aggregate floor area of Group H occupancies not located at the perimeter of the building shall not exceed 25 percent of the area limitations for the Group H occupancies as specified in Table 503. Group H fire areas shall be separated from the rest of the unlimited area building and from each other in accordance with Table 508.3.3. For two-story unlimited area buildings, the Group H fire areas shall not be located above the first story unless permitted by the allowable height in stories and feet as set forth in Table 503 based on the type of construction of the unlimited area building.

507.8 Aircraft paint hangar. The area of a one-story, Group H-2 aircraft paint hangar shall not be limited where such aircraft paint hangar complies with the provisions of Section 412.4 and is entirely surrounded by public ways or yards not less in width than one and one-half times the height of the building.

507.9 Group E buildings. The area of a one-story Group E building of Type IIA, IIIA or IV construction shall not be limited when the following criteria are met:

1. Each classroom shall have not less than two means of egress, with one of the means of egress being a direct exit to the outside of the building complying with Section 1018.
2. The building is equipped throughout with an automatic sprinkler system in accordance with Section 903.3.1.1.
3. The building is surrounded and adjoined by public ways or yards not less than 60 feet (18 288 mm) in width.

507.10 Motion picture theaters. In buildings of Type II construction, the area of a one-story motion picture theater shall not be limited when the building is provided with an automatic sprinkler system throughout in accordance with Section 903.3.1.1 and is surrounded and adjoined by public ways or yards not less than 60 feet (18 288 mm) in width.

507.11 Covered mall buildings and anchor stores. The area of covered mall buildings and anchor stores not exceeding three stories in height that comply with Section 402.6 shall not be limited.

exterior walls shall resist the intrusion of flame and embers into the structure or vents shall be screened with a corrosion-resistant, noncombustible wire mesh with $1/4$ -inch (6 mm) openings or its equivalent.

704A.3.2.2 Exterior glazing and window walls. Exterior windows, window walls, glazed doors, and glazed openings within exterior doors shall be insulating-glass units with a minimum of one tempered pane, or glass block units, or have a fire-resistance rating of not less than 20 minutes, when tested according to ASTM E 2010, or conform to the performance requirements of SFM 12-7A-2.

704A.3.2.3 Exterior door assemblies. Exterior door assemblies shall conform to the performance requirements of standard SFM 12-7A-1 or shall be of approved noncombustible construction, or solid core wood having stiles and rails not less than $1\frac{3}{8}$ inches thick with interior field panel thickness no less than $1\frac{1}{4}$ inches thick, or shall have a fire-resistance rating of not less than 20 minutes when tested according to ASTM E 2074.

Exception: Noncombustible or exterior fire-retardant treated wood vehicle access doors are not required to comply with this chapter.

704A.4 Decking, floors and underfloor protection.

704A.4.1 Decking.

704A.4.1.1 Decking surfaces. Decking, surfaces, stair treads, risers, and landings of decks, porches, and balconies where any portion of such surface is within 10 feet (3048 mm) of the primary structure shall comply with one of the following methods:

1. Shall be constructed of ignition-resistant materials and pass the performance requirements of SFM 12-7A-4, Parts A and B.
2. Shall be constructed with heavy timber, exterior fire-retardant-treated wood or approved noncombustible materials.
3. Shall pass the performance requirements of SFM 12-7A-4, Part A, 12-7A-4.7.5.1 only with a net peak heat release rate of 25kW/sq-ft for a 40-minute observation period and:
 - a. Decking surface material shall pass the accelerated weathering test and be identified as exterior type, in accordance with ASTM D 2898 and ASTM D 3201 and;
 - b. The exterior wall covering to which it the deck is attached and within 10 (3048 mm) feet of the deck shall be constructed of approved noncombustible or ignition resistant material.

Exception: Walls are not required to comply with this subsection if the decking surface material conforms to ASTM E-84 Class B flame spread.

The use of paints, coatings, stains, or other surface treatments are not an approved method of protection as required in this chapter.

704A.4.2 Underfloor and appendages protection.

704A.4.2.1 Underside of appendages and floor projections. The underside of cantilevered and overhanging appendages and floor projections shall maintain the ignition-resistant integrity of exterior walls, or the projection shall be enclosed to the grade.

704A.4.2.2 Unenclosed underfloor protection. Buildings shall have all underfloor areas enclosed to the grade with exterior walls in accordance with Section 704A.3.

Exception: The complete enclosure of under floor areas may be omitted where the underside of all exposed floors, exposed structural columns, beams and supporting walls are protected as required with exterior ignition-resistant material construction or be heavy timber.

704A.5 Ancillary buildings and structures.

704A.5.1 Ancillary buildings and structures. When required by the enforcing agency, ancillary buildings and structures and detached accessory structures shall comply with the provisions of this chapter.

1109A.8.4 Accessible parking space size. Accessible parking spaces shall comply with Sections 1109A.8.5 and 1109A.8.6.

1109A.8.5 Accessible single parking space. Where accessible single spaces are provided, they shall be constructed in accordance with the following:

1. Single spaces shall be 14 feet (4267 mm) wide and lined to provide a 9 foot (2743 mm) wide parking area and a 5 foot (1524 mm) wide loading and unloading access aisle on the passenger side of the vehicle (see Figure 11A-2B) with the vehicle parked in the forward position.
2. When more than one space is provided, two 9 foot (2743 mm) wide parking spaces may be lined on each side of a 5 foot (1524 mm) wide loading and unloading access aisle (see Figure 11A-2A, and 11A-2C).
3. The minimum length of each parking space shall be 18 feet (5486 mm).
4. The words "NO PARKING" shall be painted on the ground within each 5 foot (1524 mm) wide loading and unloading access aisle. This notice shall be painted in white letters no less than 12 inches (305 mm) high and located so that it is visible to traffic enforcement officials (see Figures 11A-2A, 11A-2B, and 11A-2C).

1109A.8.6 Van accessible parking space. One in every eight accessible spaces, but not less than one, shall be van accessible and shall be constructed in accordance with the following:

1. Each space shall be served by a loading and unloading access aisle at least 8 feet (2438 mm) wide, placed on the passenger side with the vehicle parked in the forward position.
2. The minimum length of each space shall be 18 feet (5486 mm).
3. Each space shall be designated "van accessible" as required by Section 1109A.8.8.
4. All van accessible spaces may be grouped on one level of a parking facility.
5. The words "NO PARKING" shall be painted on the ground within each 8 foot (2438 mm) wide loading and unloading access aisle. This notice shall be painted in white letters no less than 12 inches (305 mm) high and located so that it is visible to traffic enforcement officials.

Note: See Figures 11A-2A, 11A-2B, and 11A-2C.

1109A.8.7 Adjacent parking. Parking spaces adjacent to accessible parking spaces shall not be considered as loading and unloading access aisles.

1109A.8.8 Parking signage. Each accessible parking space reserved for persons with disabilities shall be identified by a reflectorized sign permanently posted immediately adjacent to and visible from each stall or space, consisting of the "International Symbol of Accessibility" in white on a dark blue background. The sign shall not be smaller than 70 square inches (4516 mm²) in area and, when in a path of

travel, shall be posted at a minimum height of 80 inches (2032 mm) from the bottom of the sign to the parking space finished grade. Signs may also be centered on the wall at the interior end of the parking space at a minimum height of 36 inches (914 mm) from the parking space finished grade, ground or sidewalk. Spaces complying with Section 1109A.8.6 shall have an additional sign stating "Van-Accessible" mounted below the symbol of accessibility.

Note: When assigned resident parking is provided, signage is not required except for unassigned or visitor parking spaces.

An additional sign shall also be posted in a conspicuous place at each entrance to off-street parking facilities or immediately adjacent to and visible from each stall or space. The sign shall not be less than 17 inches (432 mm) by 22 inches (559 mm) in size with lettering not less than 1 inch (25.4 mm) in height, and shall clearly and conspicuously state the following:

"Unauthorized vehicles parked in designated accessible spaces not displaying distinguishing placards or license plates issued for persons with disabilities may be towed away at owner's expense. Towed vehicles may be reclaimed at _____ or by telephoning _____."

Blank spaces are to be filled in with appropriate information as a permanent part of the sign.

In addition to the above requirements, the surface of each accessible parking space shall have a surface identification duplicating either of the following schemes:

1. By outlining or painting the stall or space in blue and outlining on the ground in the stall or space in white or suitable contrasting color the "International Symbol of Accessibility"; or,
2. By outlining the "International Symbol of Accessibility" in white on blue background. The "International Symbol of Accessibility" shall be located so that it is visible to a traffic enforcement officer when a vehicle is properly parked in the space and shall be 36 inches high by 36 inches wide (914 mm by 914 mm).

Note: See Figures 11A-2A, 11A-2B, and 11A-2C.

SECTION 1110A EXTERIOR ROUTES OF TRAVEL

1110A.1 Exterior accessible route. When a building or portion of a building is required to be accessible or adaptable, an accessible route shall be provided to all portions of the building, accessible building entrances and between the building and the public way. The accessible route shall be the most practical direct route and to the maximum extent feasible, coincide with the route for the general public and building residents. Exterior accessible routes shall be provided as follows:

1. Where more than one route of travel is provided, all routes shall be accessible.

2. At least one accessible route within the boundary of the site shall be provided from public transportation stops, accessible parking and accessible passenger loading and unloading zones, and public streets or sidewalks to the accessible building entrance they serve.
3. At least one accessible route shall connect accessible buildings, facilities, elements and spaces that are on the same site. Accessible routes shall be provided between accessible buildings and accessible site facilities when more than one building or facility is located on a site.
4. At least one accessible route shall connect accessible building or facility entrances with all accessible spaces, elements, and covered multifamily dwelling units.
5. An accessible route shall connect at least one accessible entrance of each covered multifamily dwelling unit with exterior spaces and facilities that serve the dwelling unit.
6. Where elevators are provided for vertical access, all elevators shall be accessible. See Section 1124A.

Note: If the slope of the finished grade between covered multifamily dwellings and a public use or common use facility (including parking) exceeds 1 unit vertical in 12 units horizontal (8.33-percent slope), or where other physical barriers (natural or artificial) or legal restrictions, all of which are outside the control of the owner, prevent the installation of an accessible route, an acceptable alternative is to provide access by a vehicular route, provided:

1. There is accessible parking on an accessible route for at least 2 percent of the covered multifamily dwelling units, and
2. Necessary site provisions such as parking spaces and curb ramps are provided at the public use or common use facility.

1110A.2 Signs. At every primary public entrance and at every major junction where the accessible route diverges from the circulation path along or leading to an accessible route, entrance or facility, there shall be a sign displaying the "International Symbol of Accessibility." Signs shall indicate the direction to accessible building entrances and facilities and shall comply with the requirements found in Section 1143A.2.

1110A.3 Flooring. If carpet or carpet tile is used in a common-use area or public-use area on a ground or floor surface, it shall have firm backing or no backing. The maximum pile height shall be 1/2 inch (12.7 mm). Exposed edges of carpet shall be fastened to floor surfaces and have trim along the entire length of the exposed edge. Carpet edge trim shall comply with Section 1111A requirements for changes in level.

1110A.3.1 Recessed doormats. Recessed doormats shall be adequately anchored to prevent interference with wheelchair traffic.

SECTION 1111A CHANGES IN LEVEL ON ACCESSIBLE ROUTES

1111A.1 Changes in level not exceeding 1/2 inch. Abrupt changes in level along any accessible route shall not exceed 1/2

inch (12.7 mm). When changes in level do occur, they shall be beveled with a slope no greater than 1 unit vertical in 2 units horizontal (50-percent slope). Changes in level not exceeding 1/4 inch (6.35 mm) may be vertical.

1111A.2 Changes greater than 1/2 inch. Changes in level greater than 1/2 inch (12.7 mm) shall be made by means of a sloped surface not greater than 1 unit vertical in 20 units horizontal (5-percent slope), or a curb ramp, ramp, elevator or special access lift. Stairs shall not be part of an accessible route. When stairs are located along or adjacent to an accessible route they shall comply with Section 1115A for exterior stairways.

SECTION 1112A CURB RAMPS ON ACCESSIBLE ROUTES

1112A.1 General. Curb ramps within the boundary of the site shall be constructed at each corner of street intersections and where a pedestrian way crosses a curb. The preferred and recommended location for curb ramps is in the center of the crosswalk of each street corner. Where it is necessary to locate a curb ramp in the center of the curb return, the street surfaces shall be marked to identify pedestrian crosswalks, and the lower end of the curb ramp shall terminate within such crosswalk areas. Curb ramps do not require handrails.

1112A.2 Obstructions. Curb ramps shall be located or protected to prevent obstruction by parked cars. Built-up curb ramps shall be located so that they do not project into vehicular traffic lanes, parking spaces, or the adjacent loading and unloading access aisle.

1112A.3 Width of curb ramps. Curb ramps shall be a minimum of 48 inches (1219 mm) in width.

1112A.4 Diagonal curb ramps. If diagonal (or corner-type) curb ramps have returned curbs or other well-defined edges, such edges shall be parallel to the direction of pedestrian flow. The bottom of diagonal curb ramps shall have a 48 inch (1219 mm) minimum clear space as shown in Figures 11A-3A through 11A-3M. If diagonal curb ramps are provided at marked crossings, the 48 inch (1219 mm) clear space shall be within the markings (see Figures 11A-3A through 11A-3M). If diagonal curb ramps have flared sides, they shall also have at least a 24-inch-long (610 mm) segment of straight curb located on each side of the curb ramp and within the marked crossing. See Figures 11A-3A through 11A-3M.

1112A.5 Slope of curb ramps. The slope of curb ramps shall not exceed 1 unit vertical to 12 units horizontal (8.33-percent slope) and shall lie, generally, in a single sloped plane. Transitions from ramps to walks, gutters, or streets shall be flush and free of abrupt changes. Maximum slopes of adjoining gutters, road surface immediately adjacent to the curb ramp, or accessible route shall not exceed 1 unit vertical to 20 units horizontal (5-percent slope) within 4 feet (1219 mm) of the top and bottom of the curb ramp.

If a curb ramp is located where pedestrians must walk across the ramp, then it shall have flared sides; the maximum slope of the flare shall be 1 unit vertical in 10 units horizontal (10-percent slope). Curb ramps with returned curbs may be used

mm) of required width. Intermediate handrails shall be located equidistant from the sides of the stairway.

Exception: Stairways serving an individual dwelling unit may have one handrail, except that stairways open on one or both sides shall have handrails on the open side or sides.

1123A.6.2 Handrail configuration.

1123A.6.2.1 Handrail heights. The top of handrails shall be 34 to 38 inches (864 to 965 mm) above the nosing of the treads.

1123A.6.2.2 Handrail ends. Ends shall be returned or shall terminate in newel posts or safety terminals.

1123A.6.2.3 Handrail extension. Handrails shall extend a minimum of 12 inches (305 mm) beyond the top nosing and 12 inches (305 mm), plus the tread width, beyond the bottom nosing. Where the extension creates a hazard, the termination of the extension shall be rounded or returned smoothly to floor, wall or post. Where the stairs are continuous from landing to landing, the inner rail shall be continuous and need not extend out into the landing. (See Figures 11A-6A and 11A-6E).

1123A.6.2.4 Handrail projections. Handrails projecting from a wall shall have a space of 1½ inches (38.1 mm) between the wall and the handrail.

Handrails may be located in a recess if the recess is a maximum of 3 inches (76.2 mm) deep and extends at least 18 inches (457 mm) above the top of the rail. Any wall or other surface adjacent to the handrail shall be free of sharp or abrasive elements. (See Figure 11A-6B).

1123A.6.2.5 Handrail grips. The handgrip portion of handrails shall not be less than ¼ inches (31.75 mm) nor more than 2 inches (50.8 mm) in cross-sectional dimension or the shape shall provide an equivalent gripping surface. The handgrip portion of handrails shall have a smooth surface with no sharp corners. Edges shall have a minimum radius of 1/8 inch (3.17 mm). Handrails shall not rotate within their fittings. (See Figure 11A-6B).

Note: For public use areas, public accommodations, and housing which is publicly funded, see Chapter 11B, Division III, Section 1133B.4.2.6 for provisions of the Division of the State Architect—Access Compliance (DSA-AC).

SECTION 1124A ELEVATORS AND SPECIAL ACCESS (WHEELCHAIR) LIFTS

1124A.1 General. Elevators provided in covered multifamily buildings shall be accessible and comply with this chapter, and Title 24, Part 7 of the California Code of Regulations.

Exception: Private elevators serving only one dwelling unit.

1124A.2 Location. Passenger elevators shall be located on a major accessible route and provisions shall be made to ensure

that they remain accessible and usable at all times that the building is occupied.

1124A.3 Size of cab and control locations.

1124A.3.1 General. Elevators serving covered multifamily buildings shall be sized to accommodate a wheelchair in accordance with this section.

Exception: When the enforcing agency determines that compliance with any requirement of this section would create an unreasonable hardship, an exception to the requirement shall be granted when equivalent facilitation is provided, and where it can be demonstrated that a person using a wheelchair can enter and operate the elevator.

1124A.3.2 Car inside. The car inside shall allow for the turning of a wheelchair. The minimum clear distance between walls or between wall and door, excluding return panels, shall not be less than 80 inches by 54 inches (2032 mm by 1372 mm) for center-opening doors, and 68 inches by 54 inches (1727 mm by 1372 mm) for side-slide opening doors. (See Figure 11A-7A). Minimum distance from wall to return panel shall not be less than 51 inches (1295 mm).

1124A.3.2.1 Door size. Elevator doors shall provide a minimum clear width of 36 inches (914 mm).

1124A.3.3 Car controls.

1124A.3.3.1 Car control location. Elevator floor buttons shall be within 54 inches (1372 mm) above the finish floor for side approach and 48 inches (1219 mm) for front approach. Except for photoelectric tube bypass switches, emergency controls, including the emergency stop and alarm, shall be grouped in or adjacent to the bottom of the panel and shall be no lower than 35 inches (889 mm) from the floor. For multiple controls only, one set must comply with these height requirements. Floor buttons shall be provided with visual indicators to show when each call is registered. The visual indicators shall be extinguished when each call is answered.

Note: Where possible, a 48-inch (1219 mm) maximum height for elevator floor buttons is preferred.

1124A.3.3.2 Car control buttons. Passenger elevator car controls shall have a minimum dimension of ¾ inch (19.05 mm) and shall be raised 1/8 inch (3.17 mm) plus or minus 1/32 inch (0.8 mm) above the surrounding surface.

Control buttons shall be illuminated, shall have square shoulders and shall be activated by a mechanical motion that is detectable.

All control buttons shall be designated by a 5/8-inch-minimum (15.87 mm) Arabic numeral, standard alphabet character, or standard symbol immediately to the left of the control button. A Braille symbol shall be located immediately below the numeral, character or symbol. A minimum clear space of 3/8 inch (9.5 mm) or other suitable means of separation shall be provided between rows of control buttons.

Note: See Figure 11A-7B.

The raised characters and symbols shall be white on a black background. Controls and emergency equipment identified by raised symbols shall include, but not be limited to, “door open”, “door close”, “alarm bell”, “emergency stop” and “telephone.” The call button for the main entry floor shall be designated by a raised star at the left of the floor designation.

1124A.3.4 Emergency telephone. The emergency telephone handset shall be positioned no higher than 48 inches (1219 mm) above the floor, and the handset cord shall be a minimum of 29 inches (737 mm) in length. If the telephone system is located in a closed compartment, the compartment door hardware shall be a lever type conforming to the provisions of Section 1003.3.1.8. Emergency intercommunication shall not require voice communication.

1124A.4 Hall call buttons. Call operation buttons shall be centered 42 inches (1067 mm) above the floor. Buttons shall be a minimum of $\frac{3}{4}$ -inch (19.05 mm) in size and shall be raised $\frac{1}{8}$ -inch (3.17 mm) plus or minus $\frac{1}{32}$ -inch (0.8 mm) above the surrounding surface. Visual indication shall be provided to show each call registered and extinguished when answered. Objects adjacent to, and below, hall call buttons shall not project more than 4 inches (101.6 mm) from the wall.

1124A.5 Minimum illumination. The minimum illumination at the car controls threshold and the landing when the car and landing doors are open shall not be less than 5 foot-candles (54 lx).

1124A.6 Hall lantern. A visual and audible signal shall be provided at each hoistway entrance indicating to the prospective passenger the car answering the call and its direction of travel as follows:

1. The visual signal for each direction shall be a minimum of $2\frac{1}{2}$ inches (63.5 mm) high by $2\frac{1}{2}$ inches (63.5 mm) wide, and visible from the proximity of the hall call button.
2. The audible signal shall sound once for the “up” direction and twice for the “down” direction or of a configuration which distinguishes between up and down elevator travel.
3. The center line of the fixture shall be located a minimum of 6 feet (1829 mm) in height from the lobby floor.
4. The use of in-car lanterns, located in or on the car doorjamb, visible from the proximity of the hall call buttons and conforming to the above requirements of this section shall or will be acceptable.

Note: The use of arrow shapes are preferred for visible signals.

1124A.7 Door delay.

1124A.7.1 Hall call. The minimum acceptable time from notification that a car is answering a call (lantern and audible signal) until the doors of the car start to close shall be calculated by the following equations but shall be no less than 5 seconds:

$$T = D / (1.5 \text{ ft/s}) \text{ or } T = D / (445 \text{ mm/s})$$

Where T is the total time in seconds and D is the distance from a point in the lobby or landing area 60 inches (1524 mm) directly in front of the farthest call button controlling that car to the centerline of its hoistway door (see Figure 11A-7D). For cars with in-car lanterns, T begins when the lantern is visible from the vicinity of hall call buttons and an audible signal is sounded.

1124A.7.2 Door delay for car calls. The minimum acceptable time for the door to remain fully open after receiving a call shall not be less than 5 seconds.

1124A.8 Doorjamb marking. All elevator hoistway entrances shall have raised floor number designations provided on both jambs. Characters shall be raised Arabic numerals a minimum of 2 inches (50.8 mm) in height with raised Braille symbols placed below the corresponding raised characters. The raised characters shall be on a contrasting background with the centerline of the characters 60 inches (1524 mm) from the floor. Braille symbols shall conform to Sections 1117B.5.5 and 1117B.5.6. On the grade level, a raised five-pointed star shall be placed to the left of the raised character. The outside diameter of the star shall be 2 inches (50.8 mm). Braille shall be placed below the corresponding raised characters (see Figure 11A-7C).

1124A.9 Door protective and reopening devices. Doors closed by automatic means shall be provided with a door-reopening device that will function to stop and reopen a car door and adjacent hoistway door in case the car door is obstructed while closing.

This reopening device shall also be capable of sensing an object or person in the path of a closing door without requiring contact for activation at a nominal 5 inches and 29 inches (127 mm and 737 mm) above the floor.

Door-reopening devices shall remain effective for a period of not less than 20 seconds. After such an interval, the doors may close in accordance with the requirements of ANSI 17.1-86 and the American Society of Mechanical Engineers (ASME) document ASME 17.1-1990.

1124A.10 Operation and leveling. The elevator shall be automatic and be provided with a self-leveling feature that will automatically bring the car to the floor landings within a tolerance of plus or minus $\frac{1}{2}$ inch (12.7 mm) under rated loading to zero loading conditions. This self-leveling shall, within its zone, be entirely automatic and independent of the operating device and shall correct the overtravel or undertravel. The car shall also be maintained approximately level with the landing, irrespective of load.

The clearance between the car platform sill and the edge of the hoistway landing shall be no greater than $1\frac{1}{4}$ inches (31.75 mm).

1124A.11 Special access (wheelchair) lifts. Special access wheelchair lifts may be provided between levels, in lieu of passenger elevators, when the vertical distance between landings, as well as the structural design and safeguards are as allowed by the State of California, the Department of Industrial Relations, Division of Occupational Safety and Health and any applicable safety regulations of other administrative authorities having jurisdiction.

6. Be capable of lowering the operator at least 18 inches (457 mm) below the surface of the water.

SECTION 1142A ELECTRICAL RECEPTACLE, SWITCH AND CONTROL HEIGHTS

1142A.1 Receptacle heights. Electrical receptacle outlets on branch circuits of 30 amperes or less and communication system receptacles shall be located no more than 48 inches (1219 mm) measured from the top of the receptacle outlet box or receptacle housing nor less than 15 inches (381 mm) measured from the bottom of the receptacle outlet box or receptacle housing to the level of the finished floor or working platform. If the reach is over an obstruction (for example, a kitchen base cabinet) between 20 and 25 inches (508 and 635 mm) in depth, the maximum height measured at the box is reduced to 44 inches (1118 mm) for forward approach, or 46 inches (1168 mm) for side approach, provided the obstruction is no more than 24 inches (610 mm) in depth. Obstructions shall not extend more than 25 inches (635 mm) from the wall beneath the receptacle.

Outlets that do not satisfy these specifications are acceptable provided that comparable outlets, that perform the same functions, are provided within the same area and are accessible.

Exceptions:

1. Receptacle outlets installed as part of permanently installed baseboard heaters are exempt.
2. Required receptacle outlets shall be permitted in floors when adjacent to sliding panels or walls.
3. Baseboard electrical outlets used in relocatable partitions, window walls or other electrical convenience floor outlets are not subject to the minimum height requirements.
4. This section shall not apply to existing buildings when the enforcing agency determines that compliance with these standards would create an unreasonable hardship.

Note: The intent of the measurement is to ensure that receptacles fall within the reach range of 15 inches to 48 inches.

1142A.2 Switch and control heights. Controls or switches intended to be used by the occupant of the room or area to control lighting and receptacle outlets, appliances, alarms or cooling, heating and ventilating equipment shall be located no more than 48 inches (1219 mm) measured from the top of the outlet box nor less than 15 inches (381 mm) measured from the bottom of the outlet box to the level of the finished floor or working platform. If the reach is over a physical barrier or an obstruction (for example, a kitchen base cabinet) between 20 and 25 inches (508 and 635 mm) in depth, the maximum height is reduced to 44 inches (1118 mm) for forward approach, or 46 inches (1168 mm) for side approach, provided the obstruction is no more than 24 inches (610 mm) in depth. Physical barriers or obstructions shall not extend more than 25 inches (635 mm) from the wall beneath a control.

Controls that do not satisfy these specifications are acceptable provided that comparable controls or outlets, that perform

the same functions, are provided within the same area and are accessible.

SECTION 1143A SIGNAGE

1143A.1 General. When signs and/or identification devices are provided they shall comply with this section.

Exception: Signs need not be provided within dwelling units.

1143A.2 Identification signs. When signs identify permanent rooms and spaces of a building or site, they shall comply with Sections 1143A.5, 1143A.6, 1143A.8, 1143A.9 and 1143A.10.

Note: See Section 1124A for additional signage requirements applicable to elevators and Section 1127A.7 for sanitary facilities.

1143A.3 Direction and informational signs. When signs direct to or give information about permanent rooms and spaces of a building or site, they shall comply with Sections 1143A.5, 1143A.6 and 1143A.7.

1143A.4 Accessibility signs. When signs identify, direct or give information about accessible elements and features of a building or site, they shall include the appropriate symbol of accessibility and shall comply with Section 1143A.5 and, when applicable, Section 1143A.10.

1143A.5 Finish and contrast. Characters, symbols and their background shall have a non glare finish. Characters and symbols shall contrast with their background, either light on a dark background or dark on a light background.

1143A.6 Proportions. Characters on signs shall have a width-to-height ratio of between 3:5 and 1:1 and a stroke width-to-height ratio of between 1:5 and 1:10.

1143A.7 Character height. Characters and numbers on signs shall be sized according to the viewing distance from which they are to be read. The minimum height is measured using an uppercase "X." Lowercase characters are permitted. For signs suspended or projected above the finish floor greater than 80 inches (2032 mm), the minimum character height shall be 3 inches (76 mm).

1143A.8 Raised characters and pictorial symbol signs. When raised characters are required or when pictorial symbols (pictograms) are used on such signs, they shall conform to the following requirements:

1. **Character Type.** Characters on signs shall be raised $\frac{1}{32}$ -inch (0.794 mm) minimum and shall be sans serif uppercase characters accompanied by Grade 2 Braille complying with Section 1143A.9.
2. **Character Size.** Raised characters shall be a minimum of $\frac{5}{8}$ inch (15.9 mm) and a maximum of 2 inches (51 mm) high.
3. **Pictorial Symbol Signs (Pictograms).** Pictorial symbol signs (pictograms) shall be accompanied by the verbal description placed directly below the pictogram. The

outside dimension of the pictogram field shall be a minimum of 6 inches (152 mm) in height.

4. **Character Placement.** Characters and Braille shall be in a horizontal format. Braille shall be placed a minimum of $\frac{3}{8}$ inch (9.5 mm) and a maximum of $\frac{1}{2}$ inch (12.7 mm) directly below the tactile characters, flush left or centered. When tactile text is multilined, all Braille shall be placed together below all lines of tactile text.

1143A.9 Braille. Contracted Grade 2 Braille shall be used wherever Braille is required in other portions of these standards. Dots shall be $\frac{1}{10}$ inch (2.54 mm) on center in each cell with $\frac{2}{10}$ -inch (5.08 mm) space between cells, measured from the second column of dots in the first cell to the first column of dots in the second cell. Dots shall be raised a minimum of $\frac{1}{40}$ inch (0.635 mm) above the background. Braille dots shall be domed or rounded.

1143A.10 Mounting location and height. Where permanent identification signs are provided for rooms and spaces, signs shall be installed on the wall adjacent to the latch side of the door. Where there is no wall space on the latch side, including at double leaf doors, signs shall be placed on the nearest adjacent wall, preferably on the right.

Where permanent identification signage is provided for rooms and spaces, it shall be located on the approach side of the door as one enters the room or space. Signs that identify exits shall be located on the same side of the door as the visual exit sign.

Mounting height shall be 60 inches (1524 mm) above the finish floor to the centerline of the sign. Mounting location shall be determined so that a person may approach within 3 inches (76 mm) of the signage without encountering protruding objects or standing within the swing of a door.

Note: See also Section 1127A.7 for additional signage requirements applicable to sanitary facilities.

**SECTION 1144A
Reserved**

**SECTION 1145A
Reserved**

**SECTION 1146A
Reserved**

**SECTION 1147A
Reserved**

**SECTION 1148A
Reserved**

**SECTION 1149A
Reserved**

Division VI—SITE IMPRACTICALITY TESTS

Division VI Table of Contents

Section 1150A Site Impracticality Tests

Test No. 1—Individual Building Test

Test No. 2—Site Analysis Test

Test No. 3—Unusual Characteristics Test

**SECTION 1150A
SITE IMPRACTICALITY TESTS**

1150A.1 General. Covered multifamily dwellings in buildings without an elevator, located on sites with difficult terrain conditions or unusual characteristics, may employ the site impracticality tests in this division for determining the accessibility and adaptability provisions required by this chapter.

Except as provided for in Section 1102A.2, the provisions of this section do not apply to multistory dwelling units in nonelevator buildings, i.e., townhouses.

SINGLE BUILDING WITH ONE COMMON (LOBBY) ENTRANCE

The following may only be used for determining required access to covered multifamily dwelling units, in a single building with one common (lobby) entrance, located on a site with difficult terrain conditions or unusual characteristics:

All ground-floor units in nonelevator buildings shall be adaptable and on an accessible route unless an accessible route to the common (lobby) entrance is not required as determined by Test No. 1, Individual Building Test, or Test No. 3, Unusual Characteristics Test, as described in this section.

Sites where either Test No. 1 or Test No. 3 is used and it is determined that an accessible route to the common (lobby) entrance is not required, at least 20 percent of the ground floor dwelling units shall comply with Division IV, and all remaining ground floor dwelling units shall comply with the features listed in Section 1150A.2 unless exempted by Test No. 3, Unusual Characteristics Test.

Test No. 1—Individual Building Test may only be used if the site has terrain over 15 percent slope.

Test No. 3—Unusual Characteristics Test may be used if applicable.

Provisions to Test Nos. 1 and 2. Where a building elevator is provided only as means of creating an accessible route to covered multifamily dwelling units on a ground floor, the building is not considered to be an elevator building for purposes of this code; hence, only the ground floor dwelling units would be covered.

TEST NO. 1—INDIVIDUAL BUILDING TEST

It is not required by this code to provide an accessible route when the terrain of the site is such that both of the following apply:

1. The slopes of the undisturbed site measured between the planned entrance and all vehicular or pedestrian

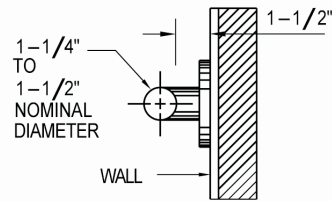

SECTION THROUGH TYPICAL GRAB BAR

THESE DIAGRAMS ILLUSTRATE THE SPECIFIC REQUIREMENTS OF THESE REGULATIONS AND ARE INTENDED ONLY AS AN AID FOR BUILDING DESIGN AND CONSTRUCTION

FIGURE 11A-9C—GRAB BAR SECTION

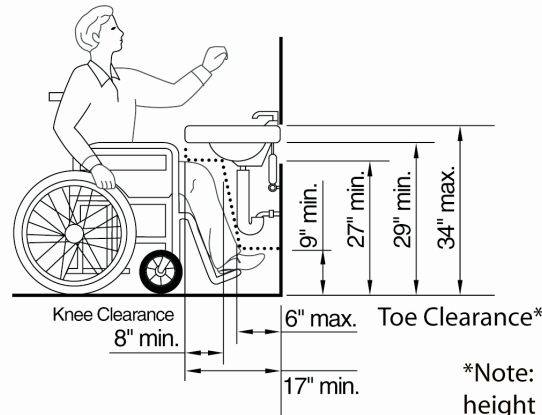

SIDE ELEVATION

*Note: If a minimum 9 inches height of toe clearance is provided, a maximum of 6 inches of the 48 inches of clear floor space required at the fixture may extend into the toe space.

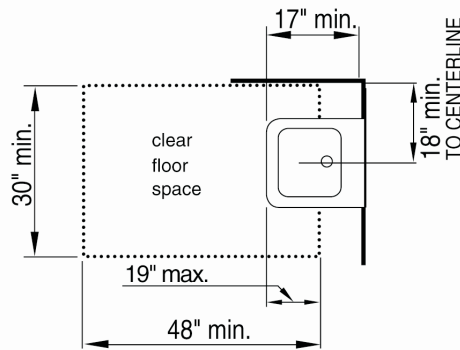

PLAN VIEW

THIS DIAGRAM ILLUSTRATES THE SPECIFIC REQUIREMENTS OF THESE REGULATIONS AND IS INTENDED ONLY AS AN AID FOR BUILDING DESIGN AND CONSTRUCTION.

FIGURE 11A-9D—KNEE CLEARANCE

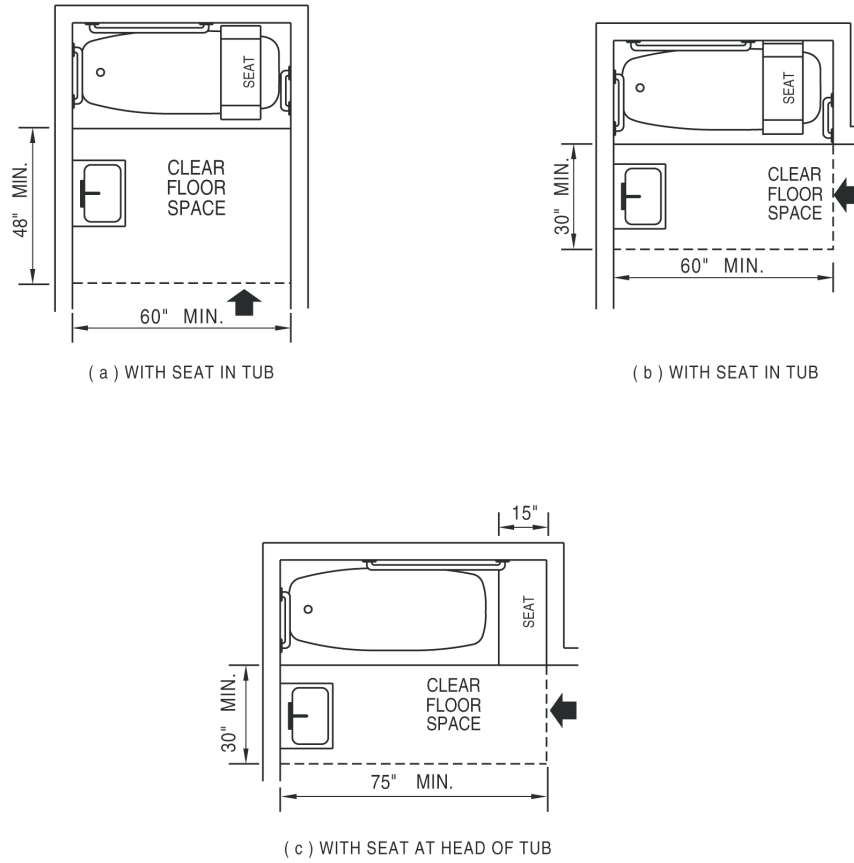

THESE DIAGRAMS ILLUSTRATE THE SPECIFIC REQUIREMENTS OF THESE REGULATIONS AND ARE INTENDED ONLY AS AN AID FOR BUILDING DESIGN AND CONSTRUCTION.

FIGURE 11A-9E—CLEAR FLOOR SPACE AT BATHTUBS

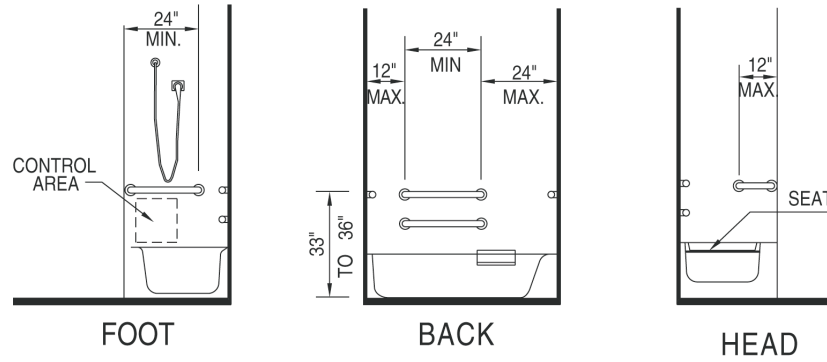

(a) WITH SEAT IN TUB

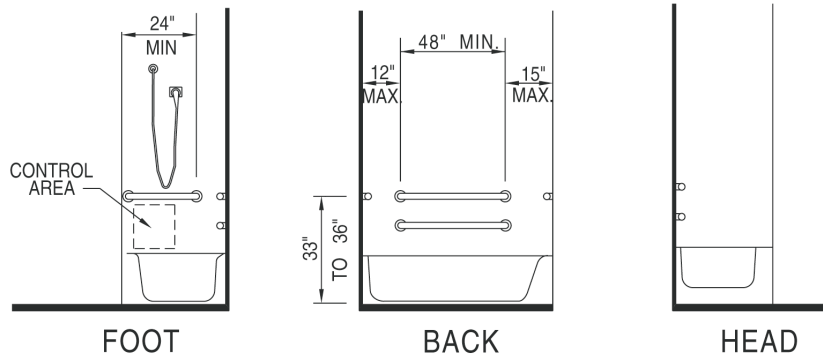

(b) WITH SEAT AT HEAD OF TUB

THESE DIAGRAMS ILLUSTRATE THE SPECIFIC REQUIREMENTS OF THESE REGULATIONS AND ARE INTENDED ONLY AS AN AID FOR BUILDING DESIGN AND CONSTRUCTION.

FIGURE 11A-9F—GRAB BARS AT BATHTUBS

an exception shall be granted when equivalent facilitation is provided.

1109B.2 Entrance. At least one accessible entrance shall be protected from the weather by canopy or roof overhang. Such entrances shall incorporate a passenger loading zone. Passenger loading zones shall provide an access aisle at least 60 inches (1524 mm) wide and 20 feet (6096 mm) long adjacent and parallel to the vehicle pull-up space. If there are curbs between the access aisle and the vehicle pull-up space, then a curb ramp complying with Chapter 11B shall be provided. Vehicle standing spaces and access aisles shall be level with surface slopes not exceeding one unit vertical in 50 units horizontal (2-percent slope) in all directions. Minimum vertical clearance of 114 inches (2896 mm) at accessible passenger loading zones and along vehicle access routes to such areas from site entrances shall be provided.

Exception: Clinics and other medical facilities that are not intended for patient stays of 24 hours or more, and that are located above the first story of a building, and that do not have a dedicated entrance from the exterior of the building at the first story.

1109B.3 Patient bedrooms and toilet rooms. Patient bedrooms and associated toilet facilities shall be made accessible as follows:

1. Long-term care facilities, including skilled nursing facilities, intermediate care facilities, bed and care and nursing homes shall have at least 50 percent of patient bedrooms and toilet rooms, and all public use and common use areas, accessible.
2. General-purpose hospitals, psychiatric facilities and detoxification facilities shall have at least 10 percent of patient bedrooms and toilets, and all public use and common use areas, accessible.
3. Hospitals and rehabilitation facilities that specialize in treating conditions that affect mobility, or units within either that specialize in treating conditions that affect mobility, shall have all patient bedrooms and toilets and all public use and common use areas accessible.

1109B.4 Patient bedroom areas. Accessible patient bedrooms shall comply with the following requirements:

1. Each bedroom shall have a turning space measuring 60 inches (1524 mm) clear in diameter; or that is a T-shaped space complying with Figure 11B-12. In rooms with two beds, it is preferable that this space be located between beds.
2. Each bedroom shall have a minimum clear floor space of 36 inches (914 mm) along each side of the bed, and shall provide an accessible route to each side of the bed.
3. Each bedroom shall have an accessible door that complies with Section 1133B.2.

1109B.5 Patient toilet rooms and bathing facilities. Patient toilet rooms and bathing facilities required to be accessible shall comply with Section 1115B.

1109B.6 Diagnostic and treatment areas. Diagnostic and treatment areas and, where applicable, at least one dressing

room, sanitary facility, etc., for each unit or suite shall be made accessible.

1109B.7 Waiting areas, offices and sanitary facilities. Waiting areas, offices and sanitary facilities serving them shall be made accessible as covered in other portions of these standards.

1109B.8 Offices and suites. In buildings that house offices and suites of physicians, dentists, etc., all such offices or suites shall be made accessible, subject to other provisions of these regulations.

**SECTION 1110B
ACCESSIBILITY FOR GROUP M OCCUPANCIES**

1110B.1 Sales.

1110B.1.1 General areas. General sales, display and office areas together with related toilet rooms shall be made accessible. See also the general requirements in Section 1114B.1.1.

Exceptions:

1. Minor specialized display areas that do not exceed 200 square feet (18.6 m²) in floor area and to which the general public is excluded need not be made accessible.
2. Offices in sales facilities that do not exceed 5,000 square feet (465 m²) in total area, that are located on nonaccessible levels, need not be made accessible.

1110B.1.2 Work areas. Sales employee workstations shall be located on accessible levels, and the customer side of sales or check-out stations shall be accessible. Employee work areas shall be sized and arranged to provide access to employees in wheelchairs.

1110B.1.3 Check stands. In new construction, check stands, including service counters requiring a surface for transactions, shall be made accessible by providing a 36-inch (914 mm) minimum clear aisle width on the customer side of the check stand. Where check stands are provided, the number of check stands that are accessible shall be as shown in Table 11B-2.

**TABLE 11B-2
CHECK STANDS**

TOTAL NUMBER OF CHECK STANDS OF EACH DESIGN	NUMBER OF CHECK STANDS OF EACH DESIGN TO BE ACCESSIBLE
1 to 4	1
5 to 8	2
9 to 15	3
over 15	3 plus 20% of additional aisles

In new and existing construction, accessible check stands shall provide a minimum clear checkout aisle width of 36 inches (914 mm) with a maximum adjoining counter height not exceeding 38 inches (965 mm) above the finish floor. The top of the counter lip shall not exceed 40 inches (1016 mm) above the finish floor. Accessible check stands shall always be open to customers with disabilities and shall be identified

by a sign clearly visible to those in wheelchairs. The sign shall display the International Symbol of Accessibility in white on a blue background and shall state: "This check stand to be open at all times for customers with disabilities."

In existing buildings, at least one checkout aisle shall be accessible in facilities with less than 5,000 square feet (465 m²) of selling space. In facilities of 5,000 square feet (465 m²) or more of selling space, at least one of each design of checkout aisle shall be made accessible when altered until the number of accessible checkout aisles of each design equals the number required in new construction.

Examples of checkout aisles of different design include those which are specifically designed to serve different functions. A different design includes, but is not limited to, the following features: length of belt or no belt, or permanent signage designating the aisle as an express lane.

1110B.1.4 Point-of-sale machines. All point-of-sale machines used by customers for the primary purpose of executing transactions between the business entity and the customer shall comply with Section 1117B.7.

1110B.1.5 Turnstiles. See Section 1133B.2.3.4.

1110B.1.6 Theft prevention barriers. Where shopping cart theft prevention barriers are used, they shall conform to the following requirements:

1. Each entrance and exit provided for public use shall be accessible to and usable by persons with disabilities.
2. Shopping cart barriers located at a public entrance or exit shall be designed to provide a clear, unobstructed opening at least 32 inches (813 mm) in width for ingress and egress of persons with disabilities.
3. Where gates are used, they shall open in the direction of travel, provide a clear unobstructed opening 32 inches (813 mm) in width and be maintained unlocked during business hours. Gates shall not operate a publicly audible alarm system or require more than 5 foot-pounds of force (22.2 N·m).
4. Where a clear unobstructed opening is provided, a level area is required on both sides of the clear opening or gate which extends a minimum of 44 inches (1118 mm) on each side of the opening and is at least 48 inches (1219 mm) in width.
5. Where a gate is used, the level area on both sides of the clear opening or gate shall be a minimum of 60 inches (1524 mm) in width and extend a minimum of 60 inches (1524 mm) (measured from the gate in a closed position) in the direction of the gate swing. The level area opposite the gate swing shall be a minimum of 48 inches (1219 mm) in width and extend a minimum of 42 inches (1067 mm).
6. Where a gate is used, the bottom of the gate shall be within 3 inches (76 mm) of the surface of the path of travel. The surface of the gate on each side shall be smooth to present no hazard to persons with disabilities using the gate and shall be structurally adequate to allow it to be opened with the wheelchair foot pedals.

7. The path of travel to and through the clear opening or gate shall be designed to prevent barriers from obstructing it and shall be continuously maintained unobstructed during business hours. Also, the design shall specifically prevent parked vehicles from obstructing ingress and egress.

8. Interior and exterior pedestrian traffic barriers (posts, rails, turnstiles, etc.) shall allow unobstructed travel for persons with disabilities through a 32-inch (813 mm) clear opening.

1110B.2 Miscellaneous general standards.

1110B.2.1 Circulation. Shelves or display units allowing self-service by customers in mercantile occupancies shall be located on an accessible route of travel complying with Section 1114B.1.2. Circulation aisles and pedestrian ways shall be sized according to functional requirements and in no case shall be less than 36 inches (914 mm) in clear width.

1110B.2.2 Storage areas. The doorway providing access to all such areas shall not be less than 32 inches (813 mm) in clear width. Storage areas shall be made accessible in the number and dimensions provided in Section 1125B.

SECTION 1111B ACCESSIBILITY FOR GROUP R OCCUPANCIES

1111B.1 General. Group R occupancies shall be accessible or adaptable as provided in this chapter. Public-use and common use areas serving adaptable guest and/or dwelling units shall be accessible. See also the general accessibility requirements in Section 1114B.1.1.

Exception: When the enforcing agency determines that compliance with any regulation under this section would create an unreasonable hardship, an exception shall be granted when equivalent facilitation is provided.

1111B.2 Public and common use rooms or areas. Public- and common use rooms and similar areas shall be made accessible to persons with disabilities, subject to specific provisions contained in other portions of these regulations. See also general requirements in Section 1114B.1.1.

At least one of each type of amenity (such as washers, dryers and similar equipment installed for the use of occupants) in each common area shall be accessible and shall be located on an accessible route to any accessible unit or sleeping accommodation.

Exception: Where elevators are not required, accessible amenities are not required on inaccessible floors as long as one of each type is provided in common areas on accessible floors.

1111B.3 Recreational facilities. When recreational facilities are provided, including swimming pools, they shall comply with Sections 1104B.4.3 and 1132B.2.

1111B.4 Hotels, motels, inns, dormitories, resorts, homeless shelters, halfway houses, transient group homes and similar places of transient lodging. Hotels, motels, inns, dormitories, resorts, homeless shelters, halfway houses, transient group homes and similar places of transient lodging shall provide

1115B.1.2 Where used by children. Where facilities are to be used solely by small children, the specific heights and clearances may be adjusted to meet their accessibility needs. See Table 1115B-1 for suggested mounting heights and clearances.

1115B.2 Bathing and shower facilities. Where facilities for bathing are provided for the public, clients or employees, including showers or bathtubs, at least one shower or bathtub and support facilities such as lockers, and not less than 1 percent of all facilities, shall be accessible and conform to the following standards:

1. **Shower areas.** Showers in all occupancies shall be finished as specified in Section 1115B.3.1, Item 6 to a height of not less than 70 inches (1778 mm) above the drain inlet. Materials other than structural elements used in such walls shall be of a type which is not adversely affected by moisture.
2. **Doors and panels.** Doors and panels of shower and bathtub enclosures shall be substantially constructed from approved, shatter-resistant materials. Hinged shower doors shall open outward.
3. **Glazing for shower and bathtub enclosures.** Glazing used in doors and panels of shower and bathtub enclosures shall be fully tempered, laminated safety glass or approved plastic. When glass is used, it shall have minimum thickness of not less than $\frac{1}{8}$ inch (3.2 mm) when fully tempered, or $\frac{1}{4}$ inch (6.4 mm) when laminated, and shall pass the test requirements of Section 2406.
4. **Plastics.** Plastics used in doors and panels of showers and bathtub enclosures shall be of a shatter-resistant type.

1115B.3 Toilet facilities.

1115B.3.1 Multiple-accommodation toilet facilities. Multiple-accommodation toilet facilities shall have the following:

1. **Wheelchair clearance.** A clear space measured from the floor to a height of 27 inches (686 mm) above the floor, within the sanitary facility room, of sufficient size to inscribe a circle with a diameter not less than 60 inches (1524 mm) in size. Other than the door to the accessible water closet compartment, a door, in any position, may encroach into this space by not more than 12 inches (305 mm).
2. **Clear floor space at fixtures.** Doors shall not swing into the clear floor space required for any fixture.
3. **Accessible water closet.** Provide a minimum of one accessible water closet in compliance with Section 1115B.4.1.
4. **Accessible water closet compartment.** Accessible water closet compartments shall comply with the following:
 - 4.1. The compartment shall be a minimum of 60 inches (1524 mm) wide.

4.2. If the compartment has a side-opening door, a minimum 60-inches-wide (1524 mm) and 60 inches-deep (1524 mm) clear floor space shall be provided in front of the water closet.

4.3. If the compartment has an end-opening door (facing the water closet), a minimum 60-inches-wide (1524 mm) and 48-inches-deep (1219 mm) clear floor space shall be provided in front of the water closet. The door shall be located in front of the clear floor space and diagonal to the water closet, with a maximum stile width of 4 inches (102 mm).

4.4. The water closet compartment shall be equipped with a door that has an automatic-closing device, and shall have a clear, unobstructed opening width of 32 inches (813 mm) when located at the end and 34 inches (864 mm) when located at the side with the door positioned at an angle of 90 degrees from its closed position.

4.5. The inside and outside of the compartment door shall be equipped with a loop or U-shaped handle immediately below the latch. The latch shall be flip-over style, sliding or other hardware not requiring the user to grasp or twist. Except for door-opening widths and door swings, a clear, unobstructed access of not less than 44 inches (1118 mm) shall be provided to water closet compartments designed for use by persons with disabilities. Maneuvering space at the compartment door shall comply with Sections 1133B.2.4.2 and 1133B.2.4.3, except that the space immediately in front of a water closet compartment shall not be less than 48 inches (1219 mm) as measured at right angles to the compartment door in its closed position.

5. **Large toilet rooms.** Where six or more compartments are provided within a multiple-accommodation toilet room, at least one compartment shall comply with Items 3 and 4 above, and at least one additional ambulatory accessible compartment shall be 36 inches (914 mm) wide with an outward swinging self-closing door and parallel grab bars complying with Section 1115B.4.1, Item 3.

6. **Interior surfaces.** In other than dwelling units, toilet room floors shall have a smooth, hard, nonabsorbent surface such as Portland cement, concrete, ceramic tile or other approved material which extends upward onto the walls at least 5 inches (127 mm). Walls within water closet compartments and walls within 24 inches (610 mm) of the front and sides of urinals shall be similarly finished to a height of 48 inches (1219 mm) and, except for structural elements, the materials used in such walls shall be a type which is not adversely affected by moisture.

1115B.3.2 Single-accommodation toilet facilities. Single-accommodation toilet facilities shall have the following:

1. **Wheelchair clearance.** There shall be sufficient space in the toilet room for a wheelchair measuring 30 inches (762 mm) wide by 48 inches (1219 mm) long to enter the room and permit the door to close. There shall be in the room a clear floor space of at least 60 inches (1524 mm) in diameter, or a T-shaped space complying with Figure 11B-12 (a) and (b). No door shall encroach into this space for more than 12 inches (305 mm). See Figure 11B-1A.
2. **Clear floor space at fixtures.** Doors shall not swing into the clear floor space required for any fixture.
3. **Accessible water closet.** Provide one accessible water closet in compliance with Section 1115B.4.1.
4. **Accessible route.** All doors, fixtures and controls shall be on an accessible route. The minimum clear width of an accessible route shall be 36 inches (914 mm) except at doors (see Section 1133B.2). If a person in a wheelchair must make a turn around an obstruction, the minimum clear width of the accessible route shall be as shown in Figure 11B-5E. See also Figure 11B-1A.
5. **Interior surfaces.** In other than dwelling units, toilet room floors shall have a smooth, hard, nonabsorbent surface such as Portland cement, concrete, ceramic tile or other approved material which extends upward onto the walls at least 5 inches (127 mm). Walls within water closet compartments and walls within 24 inches (610 mm) of the front and sides of urinals shall be similarly finished to a height of 48 inches (1219 mm) and, except for structural elements, the materials used in such walls shall be a type which is not adversely affected by moisture.
6. **Accessible lavatory.** Provide one accessible lavatory in compliance with Section 1115B.4.3.
7. **Privacy latch.** The entrance door shall contain a privacy latch which complies with Section 1117B.6, Controls and Operating Mechanisms.

For bathrooms serving residential occupancies, see Section 1111B.4.6 and Chapter 11A.

Exception: In an existing building, a single-accommodation toilet facility may have the water closet fixture located in an area which provides a clear space of not less than 36 inches (914 mm) wide by 48 inches (1219 mm) long in front of the water closet.

1115B.4 Accessible fixtures.

1115B.4.1 Accessible water closets. Water closets required to be accessible shall comply with this subsection:

1. The centerline of the water closet fixture shall be 18 inches (457 mm) from the side wall or partition. On the other side of the water closet, provide a minimum of 28 inches (711 mm) wide clear floor space if the water closet is adjacent to a fixture or a minimum of 32 inches (813 mm) wide clear floor space if the water

closet is adjacent to a wall or partition. This clear floor space shall extend from the rear wall to the front of the water closet.

2. A minimum 60 inches (1524 mm) wide and 48 inches (1219 mm) deep clear floor space shall be provided in front of the water closet.
3. Grab bars for water closets not located within a compartment shall comply with Section 1115B.7 and shall be provided on the side wall closest to the water closet and on the rear wall. Grab bars for water closets located within an accessible compartment shall comply with Section 1115B.7 and shall be provided on the side wall closest to the water closet and on the rear wall. Grab bars for water closets located within ambulatory accessible compartments shall comply with Section 1115B.7 and shall be provided on both sides of the compartment.

Grab bars shall not project more than 3 inches (76 mm) into the required clear floor space.

- 3.1. **Side wall.** The side grab bar shall be 42 inches (1067 mm) long minimum, located 12 inches (305 mm) maximum from the rear wall and extend 54 inches (1372 mm) minimum from the rear wall with the front end positioned 24 inches (610 mm) minimum in front of the water closet. The side grab bar shall be securely attached and centered 33 inches (838 mm) above and parallel to the floor.
- 3.2. **Rear wall.** The rear grab bar shall be 36 inches (914 mm) long minimum and extend from the centerline of the water closet 12 inches (305 mm) minimum on one side and 24 inches (610 mm) minimum on the other side. The rear grab bar shall be securely attached and centered 33 inches (838 mm) above and parallel to the floor, except that where a tank-type toilet is used which obstructs placement at 33 inches (838 mm), the grab bar may be as high as 36 inches (914 mm) and the space between the grab bar and the top of the tank shall be 1½ inches (38 mm) minimum.
4. The height of accessible water closets shall be a minimum of 17 inches (432 mm) and a maximum of 19 inches (483 mm) measured to the top of a maximum 2-inch (51 mm) high toilet seat.

Exception: A 3-inch (76 mm) high seat shall be permitted only in alterations where the existing fixture is less than 15 inches (381 mm) high.
5. Controls shall be operable with one hand and shall not require tight grasping, pinching or twisting. Controls for the flush valves shall be mounted on the wide side of toilet areas, no more than 44 inches (1118 mm) above the floor. The force required to activate controls shall be no greater than 5 pounds-force (lbf) (22.2 N).
6. See Section 1134A.7 for additional requirements for water closets in publicly funded housing and all non-residential occupancies.

1121B.2.1 New construction. Where provided, bus stop pads shall have a firm, stable surface with a minimum clear length of 96 inches (2438 mm) (measured from the curb or vehicle roadway edge) and a minimum clear width of 60 inches (1524 mm) (measured parallel to the vehicle roadway) to the maximum extent allowed by legal or site constraints. Bus stop pads shall connect to streets, sidewalks or pedestrian paths as part of an accessible route complying with Section 1114B.1.2. Newly constructed bus stop pads must provide a square curb surface between the pad and road or other detectable warning in accordance with Section 1133B.8.5.

Bus stop pads shall be at the same slope as the roadway in the direction parallel to roadway, and maximum 2-percent slope perpendicular to roadway.

Where provided, bus stop shelters shall be installed so as to permit a wheelchair user to enter the shelter from the public way and access a clear floor area of 30 inches by 48 inches (762 mm by 1219 mm) complying with Section 1118B.4, completely within the shelter. Such shelters shall be connected by an accessible route to the boarding area. Where provided, all bus route identification signs shall comply with Section 1117B.5.1, Item 2.

Only approved DSA-AC detectable warning products and directional surfaces shall be installed as provided in the California Code of Regulations (CCR), Title 24, Part 1, Articles 2, 3 and 4. Refer to CCR Title 24, Part 12, Chapters 12-11A and B, for building and facility access specifications for product approval for detectable warning products and directional surfaces.

Detectable warning products and directional surfaces installed after January 1, 2001, shall be evaluated by an independent entity, selected by the Department of General Services, Division of the State Architect—Access Compliance, for all occupancies, including transportation and other outdoor environments, except that when products and surfaces are for use in residential housing, evaluation shall be in consultation with the Department of Housing and Community Development. See Government Code Section 4460.

1121B.2.2 Bus stop siting and alterations.

1. Bus stop sites shall be chosen such that the areas where lifts or ramps are to be deployed comply with Section 1121B.2.1.
2. When new bus route identification signs are installed or old signs are replaced, they shall comply with the requirements of Section 1121B.2.1.

1121B.3 Fixed facilities and stations.

1121B.3.1 New construction. New stations in rapid rail, light rail, commuter rail, intercity bus, intercity rail, high speed rail and other fixed guideway systems (for example, automated guideway transit, monorails, etc.) shall comply with the following provisions, as applicable:

1. Elements such as ramps, elevators or other circulation devices, fare vending or other ticketing areas, and fare collection areas shall be placed to minimize the distance which wheelchair users and other per-

sons who cannot negotiate steps may have to travel compared to the general public. The circulation paths, each including an accessible entrance and an accessible route, for persons with disabilities shall, to the maximum extent practicable, coincide with the circulation path for the general public. Where a circulation path is different, signage complying with Section 1117B.5.1, Items 2 and 3, shall be provided to indicate direction to and identify the accessible entrance and accessible route.

2. If different entrances to a station serve different transportation fixed routes or groups of fixed routes, entrances serving each group or route shall comply with Section 1133B.1.
3. Direct connections to commercial, retail or residential facilities shall have an accessible route complying with Section 1114B.1.2 from the point of connection to boarding platforms and all transportation system elements used by the public. Any elements provided to facilitate future direct connections shall be on an accessible route connecting boarding platforms and all transportation system elements used by the public.
4. Where signs are provided at entrances to stations identifying the station or the entrance, or both, at least one sign at each entrance shall comply with Section 1117B.5.1, Item 1. Such signs shall be placed in uniform locations at entrances within the transit system.

Exception: Where the station has no defined entrance, but signage is provided, the accessible signage shall be placed in a central location.

5. Stations covered by this section shall have identification signs complying with Section 1117B.5.1, Item 2. Signs shall be placed at frequent intervals and shall be clearly visible from within the vehicle on both sides when not obstructed by another train. When station identification signs are placed close to vehicle windows (that is, on the side opposite from boarding) each shall have the top of the highest letter or symbol below the top of the vehicle window and the bottom of the lowest letter or symbol above the horizontal mid-line of the vehicle window.
6. Lists of stations, routes or destinations served by the station and located on boarding areas, platforms or mezzanines shall comply with Section 1117B.5.1, Item 2. A minimum of one sign identifying the specific station and complying with Section 1117B.5.1, Item 1, shall be provided on each platform or boarding area. All signs referenced in this paragraph shall be placed in uniform locations within the transit system.
7. Automatic fare vending, collection and adjustment (for example, add-fare) systems shall comply with Section 1117B.7. Such devices shall be located on an accessible route complying with Section 1114B.1.2.

If self-service fare collection devices are provided for the use of the general public, a minimum of 5 percent but not less than one accessible device for entering, and at least one for exiting, unless one device serves both functions, shall be provided at each location where such devices are provided.

Accessible fare collection devices shall have a minimum clear opening width of 32 inches (813 mm) and shall comply with the applicable requirements of Section 1117B.6.

Gates which must be pushed open by wheelchair or mobility aid users shall have a smooth continuous surface extending from 2 inches (51 mm) above the floor to 27 inches (686 mm) above the floor and shall comply with Sections 1133B.1 and 1133B.2.

8. Platform edges bordering a drop-off and not protected by platform screens or guards shall have a detectable warning. Such detectable warnings shall comply with the following provisions as applicable, and shall run the full length of the platform drop-off.

(a) **Detectable warnings at transit boarding platforms.**

Transit boarding platforms shall have a detectable warning texture extending the full length of the loading area. This detectable warning texture shall have the following features:

Width 24 to 36 inches (610 mm to 914 mm) placed at the edge of the drop-off or safe area.

Durable, slip-resistant material having a surface texture composed of raised, truncated domes in a staggered pattern with a diameter of nominal 0.9 inch (22.9 mm) at the base tapering to 0.45 inch (11.4 mm) at the top, a height of nominal 0.2 inch (5.08 mm), and a center-to-center spacing of nominal 2.35 inches (59.7 mm) in compliance with Figure 11B-23A. "Nominal" as used here shall be in accordance with California State Referenced Standards Code Sections 12-11A and B-102. The detectable warning shall contrast visually with adjoining surfaces, either light on dark or dark on light. The material used to provide contrast shall be an integral part of the walking surface. Warning surfaces shall differ from adjoining walking surfaces in resiliency or sound-on-cane contact. This surface shall be reserved for warning.

Color yellow conforming to Federal Color No. 33538, as shown in Table IV of Standard No. 595B. Where the color value contrast between the yellow warning and the main walking surface is less than 70 percent, a 1 inch-wide (25 mm) black strip shall separate the yellow warning from the main walking surface. Contrast shall be determined by:

Contrast = $[(B1-B2/B1)] \times 100$ percent
where B1 = light reflectance value (LRV) of the lighter area and B2 = light reflectance value (LRV) of the darker area.

Only approved DSA-AC detectable warning products and directional surfaces shall be installed as provided in the California Code of

Regulations (CCR), Title 24, Part 1, Articles 2, 3 and 4. Refer to CCR Title 24, Part 12, Chapters 12-11A and B, for building and facility access specifications for product approval for detectable warning products and directional surfaces.

Detectable warning products and directional surfaces installed after January 1, 2001, shall be evaluated by an independent entity, selected by the Department of General Services, Division of the State Architect—Access Compliance, for all occupancies, including transportation and other outdoor environments, except that when products and surfaces are for use in residential housing, evaluation shall be in consultation with the Department of Housing and Community Development. See Government Code Section 4460.

(b) **Detectable directional texture at boarding platforms.**

At transit boarding platforms, the pedestrian access shall be identified with a detectable directional texture. This detectable directional texture shall comply with Figure 11B-23B and shall be 0.1 inch (2.54 mm) in height that tapers off to 0.04 inch (1.02 mm), with bars raised 0.2 inch (5.08 mm) from the surface. The raised bars shall be 1.3 inches (33.02 mm) wide and 3 inches (76 mm) from center-to-center of each bar. This surface shall differ from adjoining walking surfaces in resiliency or sound-on-cane contact. The color of the directional texture shall comply with Section 1121B.3.1, Item 8(a). This surface will be placed directly behind the yellow detectable warning texture specified in Section 1121B.3.1, Item 8(a), aligning with all doors of the transit vehicles where passengers will embark. The width of the directional texture shall be equal to the width of the transit vehicle's door opening. The depth of the texture shall not be less than 36 inches (914 mm).

Only approved DSA-AC detectable warning products and directional surfaces shall be installed as provided in the California Code of Regulations (CCR), Title 24, Part 1, Articles 2, 3 and 4. Refer to CCR Title 24, Part 12, Chapters 12-11A and B, for building and facility access specifications for product approval for detectable warning products and directional surfaces.

Detectable warning products and directional surfaces installed after January 1, 2001, shall be evaluated by an independent entity, selected by the Department of General Services, Division of the State Architect—Access Compliance, for all occupancies, including transportation and other outdoor environments, except that when products and surfaces are for use in residential housing, evaluation shall be in consultation with the Department of Housing and Community Development. See Government Code Section 4460.

9. In stations covered by this section, rail-to-platform height in new stations shall be coordinated with the floor height of new vehicles so that the vertical dif-

the California Code of Regulations (CCR), Title 24, Part 1, Articles 2, 3 and 4. Refer to CCR Title 24, Part 12, Chapters 12-11A and B, for building and facility access specifications for product approval for detectable warning products and directional surfaces.

Detectable warning products and directional surfaces installed after January 1, 2001, shall be evaluated by an independent entity, selected by the Department of General Services, Division of the State Architect—Access Compliance, for all occupancies, including transportation and other outdoor environments, except that when products and surfaces are for use in residential housing, evaluation shall be in consultation with the Department of Housing and Community Development. See Government Code Section 4460.

8. **Obstructions.** Curb ramps shall be located or protected to prevent their obstruction by parked vehicles.
9. **Diagonal curb ramps.** If diagonal (or corner-type) curb ramps have returned curbs or other well-defined edges, such edges shall be parallel to the direction of pedestrian flow. The bottom of diagonal curb ramps shall have 48 inches (1219 mm) minimum clear space as shown in Figures 11B-22(c) and (d). If diagonal curb ramps are provided at marked crossings, the 48-inch (1219 mm) clear space shall be within the markings [see Figures 11B-22(c) and (d)]. If diagonal curb ramps have flared sides, they shall also have at least a 24 inch (610 mm) long segment of straight curb located on each side of the curb ramp and within the marked crossing [see Figure 11B-22 (c)].

Notes:

1. For additional curb details, see Figures 11B-19A and 11B-19B.
2. If the distance from the curb to the back of sidewalk is too short to accommodate a ramp and a 4-foot (1219 mm) platform as in Figure 11B-20A, Case A, the sidewalk may be depressed longitudinally as in Figure 11B-20A, Case B, or Figure 11B-20B, Case C, or may be widened as in Figure 11B-20B, Case D.
3. If the sidewalk is less than 5 feet (1524 mm) wide, the full width of the sidewalk shall be depressed as shown in Figure 11B-20B, Case C.
4. As an alternate to Figure 11B-20A, Case A, one ramp may be placed in the center of the curb return as in Figure 11B-20C, Case E.
5. When a ramp is located in the center of a curb return, the crosswalk configuration must be similar to that shown on the plan to accommodate wheelchairs. See Figure 11B-22.
6. If the planting area width is equal to or greater than the ramp length, the ramp side slope distance equals 3 feet (914 mm). See Figure 11B-20D, Case G.
7. For Figure 11B-20C, Case F, and Figure 11B-20D, Case G, the longitudinal portion of

the sidewalk may need to be depressed as shown in Figure 11B-20A, Case B.

8. If located on a curve, the sides of the ramp need not be parallel, but the minimum width of the ramp shall be 4 feet (1219 mm).
9. The ramp shall have a 12-inch-wide (305 mm) border with $\frac{1}{4}$ -inch (6 mm) grooves approximately $\frac{3}{4}$ inch (19 mm) on center. See grooving detail, Figure 11B-20D, Case H.

SECTION 1128B PEDESTRIAN GRADE SEPARATIONS (OVERPASSES AND UNDERPASSES)

Pedestrian ramps on pedestrian grade separations shall comply with the requirements of Section 1133B.5 for ramps.

Cross slopes of walking surfaces shall be the minimum possible and shall not exceed $\frac{1}{4}$ inch (6 mm) per foot (2.083-percent gradient). The slope of any appreciably warped walking surface shall not exceed one unit vertical in 12 units horizontal (8.33-percent slope) in any direction. Where pedestrian grade separations cross streets or other vehicular traffic ways, and where a street level crossing can reasonably and safely be used by persons with physical disabilities, there shall be provided conforming curb ramps and a usable pathway.

Exceptions:

1. When the grade differential of the walking surface of a pedestrian grade separation exceeds 14 feet (4267 mm) due to required height clearance and grade conditions, and the enforcing agency finds that because of right-of-way restrictions, topography or natural barriers, wheelchair accessibility or equivalent facilitation would create an unreasonable hardship, such accessibility need not be provided. However, the requirements in these regulations relating to other types of mobility shall be complied with.
2. For existing facilities, this section shall not apply where, due to legal or physical constraints, the site of the project will not allow compliance with these regulations or equivalent facilitation without creating an unreasonable hardship. See Section 109.1.5.

SECTION 1129B ACCESSIBLE PARKING REQUIRED

1129B.1 General. Each lot or parking structure where parking is provided for the public as clients, guests or employees, shall provide accessible parking as required by this section. Accessible parking spaces serving a particular building shall be located on the shortest accessible route of travel (complying with Section 1114B.1.2) from adjacent parking to an accessible entrance. In parking facilities that do not serve a particular building, accessible parking shall be located on the shortest accessible route of travel to an accessible pedestrian entrance of the parking facility. In buildings with multiple accessible entrances with adjacent parking, accessible parking spaces

shall be dispersed and located closest to the accessible entrances. Table 11B-6 establishes the number of accessible parking spaces required.

1129B.2 Medical care outpatient facilities. At facilities providing medical care and other services for persons with mobility impairments, parking spaces complying with this section shall be provided in accordance with Table 11B-6 except as follows:

1. **Outpatient units and facilities.** Ten percent of the total number of parking spaces provided shall serve each such outpatient unit or facility.
2. **Units and facilities that specialize in treatment or services for persons with mobility impairments.** Twenty percent of the total number of parking spaces provided shall serve each such unit or facility.

**TABLE 11B-6
SPACES REQUIRED**

Establishes the number of accessible parking spaces required.

TOTAL NUMBER OF PARKING SPACES IN LOT OR GARAGE	MINIMUM REQUIRED NUMBER OF SPACES
1-25	1
26-50	2
51-75	3
76-100	4
101-150	5
151-200	6
201-300	7
301-400	8
401-500	9
501-1,000	*
1,001 and over	**

* Two percent of total.

** Twenty plus one for each 100, or fraction over 1,001.

1129B.3 Parking space size. Accessible parking spaces shall be located as near as practical to a primary entrance and shall be sized as follows:

1. **Dimensions.** Where single spaces are provided, they shall be 14 feet (4267 mm) wide and lined to provide a 9-foot (2743 mm) parking area and a 5-foot (1524 mm) loading and unloading access aisle on the passenger side of the vehicle. When more than one space is provided in lieu of providing a 14-foot-wide (4267 mm) space for each parking space, two spaces can be provided within a 23-foot-wide (7010 mm) area lined to provide a 9-foot (2743 mm) parking area on each side of a 5-foot (1524 mm) loading and unloading access aisle in the center. See Figure 11B-18A. Parking access aisles shall be part of an accessible route of travel (complying with Section 1114B.1.2) to the building or facility entrance. Parked vehicle overhangs shall not reduce the clear width of an accessible route. The minimum length of each parking space, shall be 18 feet (5486 mm). The words "NO PARKING" shall be painted on the ground within each 5-foot (1524 mm) loading and unloading access aisle.

This notice shall be painted in white letters no less than 12 inches (305 mm) high and located so that it is visible to traffic enforcement officials. See Figures 11B-18A, 11B-18B and 11B-18C.

2. **Van space(s).** One in every eight accessible spaces, but not less than one, shall be served by an access aisle 96 inches (2438 mm) wide minimum placed on the side opposite the driver's side when the vehicle is going forward into the parking space and shall be designated van accessible as required by Section 1129B.4. All such spaces may be grouped on one level of a parking structure. The words "NO PARKING" shall be painted on the ground within each 8-foot (2438 mm) loading and unloading access aisle. This notice shall be painted in white letters no less than 12 inches (305 mm) high and located so that it is visible to traffic enforcement officials. See Figures 11B-18A, 11B-18B and 11B-18C.
3. **Arrangement of parking space.** In each parking area, a bumper or curb shall be provided and located to prevent encroachment of cars over the required width of walkways. Also, the space shall be so located that persons with disabilities are not compelled to wheel or walk behind parked cars other than their own. Pedestrian ways which are accessible to persons with disabilities shall be provided from each such parking space to related facilities, including curb cuts or ramps as needed. Ramps shall not encroach into any accessible parking space or the adjacent access aisle. The maximum cross slope in any direction of an accessible parking space and adjacent access aisle shall not exceed 2 percent.

Exceptions: See Figures 11B-18A through 11B-18C.

1. Where the enforcing agency determines that compliance with any regulation of this section would create an unreasonable hardship, a variance or waiver may be granted when equivalent facilitation is provided.
2. Parking spaces may be provided which would require a person with a disability to wheel or walk behind other than accessible parking spaces when the enforcing agency determines that compliance with these regulations or providing equivalent facilitation would create an unreasonable hardship. See Section 109.1.5.
4. **Slope of parking space.** Surface slopes of accessible parking spaces shall be the minimum possible and shall not exceed one unit vertical to 50 units horizontal (2-percent slope) in any direction.

1129B.4 Identification of parking spaces for off-street parking facilities. Each parking space reserved for persons with disabilities shall be identified by a reflectorized sign permanently posted immediately adjacent to and visible from each stall or space, consisting of the International Symbol of Accessibility in white on a dark blue background. The sign shall not be smaller than 70 square inches (4516 mm²) in area and, when in a path of travel, shall be posted at a minimum height of 80 inches (2032 mm) from the bottom of the sign to the parking space finished grade. Signs may also be centered on the wall at the interior end of the parking space.

bars or other hardware designed to provide passage. Locked exit doors shall operate as above in egress direction.

1133B.2.5.3 Recessed doors. Where the plane of the doorway is offset 8 or more inches (205 mm) from any obstruction within 18 inches (455 mm) measured laterally on the latch side, the door shall be provided with maneuvering clearance for front approach. See Figure 11B-33(a).

1133B.2.6 Smooth surface. The bottom 10 inches (254 mm) of all doors except automatic and sliding shall have a smooth, uninterrupted surface to allow the door to be opened by a wheelchair footrest without creating a trap or hazardous condition. Where narrow frame doors are used, a 10-inch (254 mm) high smooth panel shall be installed on the push side of the door, which will allow the door to be opened by a wheelchair footrest without creating a trap or hazardous condition.

1133B.3 Corridors, hallways and exterior exit balconies.

1133B.3.1 Corridor and hallway widths. Every corridor and hallway serving an occupant load of 10 or more shall not be less than 44 inches (1118 mm) in width. Corridors and hallways serving an occupant load of less than 10 shall not be less than 36 inches (914 mm) in width.

1133B.3.2 Corridors and hallways over 200 feet (60 960 mm). Corridors and hallways that are located on an accessible route and exceed 200 feet (60 960 mm) in length shall have a minimum clear width of 60 inches (1524 mm), then passing spaces at least 60 inches by 60 inches (1524 mm by 1524 mm) shall be located at reasonable intervals not to exceed 200 feet (60 960 mm). A "T" intersection of two corridors or walks is an acceptable passing place.

Exceptions:

1. In existing buildings, when the enforcing agency determines that compliance with any building standard under this section would create an unreasonable hardship, an exception to such building standard shall be granted when equivalent facilitation is provided.
2. In existing buildings, the provisions of this section shall not apply when legal or physical constraints will not allow compliance with these building standards or equivalent facilitation without creating an unreasonable hardship. See Section 109.1.5.

1133B.4 Stairways.

1133B.4.1 Handrails.

1133B.4.1.1 Required handrails. Stairways shall have handrails on each side, and every stairway required to be more than 88 inches (2235 mm) in width shall be provided with not less than one intermediate handrail for each 88 inches (2235 mm) of required width. Intermediate handrails shall be spaced approximately equally across with the entire width of the stairway. Handrails shall be continuous along both sides of a stairway.

1133B.4.2 Handrail configuration.

1133B.4.2.1 The top of handrail gripping surface shall be mounted between 34 to 38 inches (864 to 965 mm) above the nosing of the treads.

1133B.4.2.2 Handrails shall extend a minimum of 12 inches (305 mm) beyond the top nosing and 12 inches (305 mm), plus the tread width, beyond the bottom nosing. At the top, the extension shall be parallel with the floor or ground surface. At the bottom, the handrail shall continue to slope for a distance of the width of one tread from the bottom riser; the remainder of the extension shall be horizontal. See Figures 11B-35 and 11B-37.

Exceptions:

1. In new construction, the inside handrail on switchback or dogleg stairs shall always be continuous.
2. In existing buildings and facilities, full extension of handrails at stairs shall not be required in alterations where such extensions would be hazardous or impossible due to plan configuration.

1133B.4.2.3 Ends shall be returned smoothly to floor, wall or post.

1133B.4.2.4 The orientation of at least one handrail shall be in the direction of the run of the stair and perpendicular to the direction of the stair nosing, and shall not reduce the minimum required width of the stairs.

1133B.4.2.5 Handrails projecting from a wall shall have a space of 1½ inches (38 mm) between the wall and the handrail.

Handrails may be located in a recess if the recess is a maximum of 3 inches (76 mm) deep and extends at least 18 inches (457 mm) above the top of the rail. Handrails shall not rotate in their fittings.

1133B.4.2.6 Handgrips. The handgrip portion of handrails shall be not less than 1¼ inches (32 mm) or more than 1½ inches (38 mm) in cross-sectional nominal dimension or the shape shall provide an equivalent gripping surface. The handgrip portion of handrails shall have a smooth surface with no sharp corners. Gripping surfaces (top or sides) shall be uninterrupted by newel posts, other construction elements or obstructions. Any wall or other surface adjacent to the handrail shall be free of sharp or abrasive elements. Edges shall have a minimum radius of 1/8 inch (3.2 mm).

Exceptions:

1. In existing buildings when the enforcing agency determines that compliance with any requirement under Section 1133B.4.2 would create an unreasonable hardship, an exception to the requirement for persons with disabilities may be granted when equivalent facilitation is provided.
2. These regulations shall not apply in existing buildings where legal or physical constraints will not allow compliance with these regulations or equivalent facilitation without creating an unreasonable hardship. See Section 109.1.5.

1133B.4.3 Tactile floor designation signs in stairways.

Tactile floor designation signs that comply with Section 1117B.5, Item 1, shall be located at each floor level landing in all enclosed stairways in buildings two or more stories in height to identify the floor level. At exit discharge level, the sign shall include a raised five-pointed star located to the left of the identifying floor level. The outside diameter of the star shall be the same as the height of the raised characters.

1133B.4.4 Striping for the visually impaired. The upper approach and the lower tread of each stair shall be marked by a strip of clearly contrasting color at least 2 inches (51 mm) wide placed parallel to and not more than 1 inch (25.4 mm) from the nose of the step or landing to alert the visually impaired. The strip shall be of material that is at least as slip resistant as the other treads of the stair.

Where stairways occur outside a building, the upper approach and all treads shall be marked by a strip of clearly contrasting color at least 2 inches (51 mm) wide and placed parallel to and not more than 1 inch (25.4 mm) from the nose of the step or landing to alert the visually impaired. The strip shall be of a material that is at least as slip resistant as the other treads of the stair. A painted strip shall be acceptable.

1133B.4.5 Treads, nosing and risers.

1133B.4.5.1 Treads. All tread surfaces shall be slip resistant. Weather-exposed stairs and their approaches shall be designed so that water will not accumulate on the walking surfaces. Treads shall have smooth, rounded or chamfered exposed edges, and no abrupt edges at the nosing (lower front edge). The radius of curvature at the leading edge of the tread shall be no greater than 1/2 inch (12.7 mm).

1133B.4.5.2 Nosing. Nosing shall not project more than 1 1/2 inches (38 mm) past the face of the riser below.

1133B.4.5.3 Open risers are not permitted. On any given flight of stairs, all steps shall have uniform riser height and uniform tread widths consistent with Section 1133B.4. Stair treads shall be no less than 11 inches (279 mm) deep, measured from riser to riser. See Figure 11B-35. Risers shall be sloped or the underside of the nosing shall have an angle not less than 60 degrees from the horizontal.

Exceptions:

1. In existing buildings, when the enforcing agency determines that compliance with any requirement under this section would create an unreasonable hardship, an exception to persons with disabilities requirements may be granted when equivalent facilitation is provided.
2. These regulations shall not apply to existing buildings when legal or physical constraints will not allow compliance with these regulations or equivalent facilitation without creating an unreasonable hardship. See Section 109.1.5.

1133B.5 Ramps.

1133B.5.1 General. Ramps used as exits shall conform to the provisions of this section. Any accessible route of travel shall be considered a ramp if its slope is greater than 1 foot (305 mm) rise in 20 feet (6096 mm) of horizontal run (5-percent gradient).

1133B.5.2 Width. Pedestrian ramps shall have a minimum clear width of 48 inches (1219 mm), unless required to be wider by some other provision of this code. Pedestrian ramps serving entrances to buildings where the ramp is the only exit discharge path and serves an occupant load of 300 or more shall have a minimum clear width of 60 inches (1524 mm). Ramps serving Group R occupancies may be 36 inches (914 mm) clear width when the occupant load is 50 or less.

1133B.5.3 Slope. The least possible slope shall be used for any ramp. The maximum slope of a ramp that serves any exit way, provides access for persons with physical disabilities or is in the accessible route of travel shall be 1-foot (305 mm) rise in 12 feet (3658 mm) of horizontal run (8.3-percent gradient). The maximum rise for any run shall be 30 inches (762 mm). Examples of ramp dimensions are as follows:

SLOPE	MAXIMUM RISE		MAXIMUM HORIZONTAL PROJECTION	
	inches	mm	feet	m
1:12 to < 1:16	30	760	30	9
1:16 to < 1:20	30	760	40	12

1133B.5.3.1 The cross slope of ramp surfaces shall be no greater than one unit vertical in 50 units horizontal (2-percent slope).

1133B.5.4 Landings. Level ramp landings shall be installed as follows:

1133B.5.4.1 Location of landings. Level ramp landings shall be provided at the top and bottom of each ramp. Intermediate landings shall be provided at intervals not exceeding 30 inches (762 mm) of vertical rise and at each change of direction. Landings are not considered in determining the maximum horizontal distance of each ramp. Landings shall be level as specified in the definition of "Level area" in Section 1102B.

1133B.5.4.2 Size of top and bottom landings. Top landings shall be not less than 60 inches (1524 mm) wide and shall have a length of not less than 60 inches (1524 mm) in the direction of ramp run. Landings at the bottom of ramps shall have a dimension in the direction of ramp run of not less than 72 inches (1829 mm).

1133B.5.4.3 Encroachment of doors. Doors in any position shall not reduce the minimum dimension of the landing to less than 42 inches (1067 mm) and shall not reduce the required width by more than 3 inches (76 mm) when fully open. See Figure 11B-39(b).

1133B.5.4.4 Strike edge extension. The width of the landing shall extend 24 inches (610 mm) past the strike edge of any door or gate for exterior ramps and 18 inches (457 mm) past the strike edge for interior ramps.

1133B.5.4.5 Landing width. At bottom and intermediate landings, the width shall be at least the same as required for the ramps.

1133B.5.4.6 Change of direction. Intermediate and bottom landings at a change of direction in excess of 30 degrees shall have a dimension in the direction of ramp run of not less than 72 inches (1829 mm) to accommodate the handrail extension.

1133B.5.4.7 Other intermediate landings. Other intermediate landings shall have a dimension in the direction of ramp run of not less than 60 inches (1524 mm).

1133B.5.4.8 For existing ramps or ramps not covered by Section 1133B.5.4.1, landings shall be provided as set forth in Section 1133B.5.4.1.

1133B.5.4.9 Hazards. Required ramps shall have a curb at least 2 inches (51 mm) high, or a wheel guide rail 2 to 4 inches (51 to 102 mm) high on each side of the ramp landing that has a vertical drop exceeding 4 inches (102 mm) and that is not bounded by a wall or fence.

1133B.5.5 Handrails for ramps.

1133B.5.5.1 Handrails are required on ramps that provide access if the slope exceeds 1 foot (305 mm) rise in 20 feet (6096 mm) of horizontal run (5-percent gradient), except that at exterior door landings, handrails are not required on ramps less than 6 inches (152 mm) rise or 72 inches (1829 mm) in length. Handrails shall be placed on each side of each ramp, shall be continuous the full length of the ramp, shall be 34 to 38 inches (864 to 965 mm) above the ramp surface to the top of the handrails, shall extend a minimum of 1 foot (305 mm) beyond the top and bottom of the ramp and shall be parallel with the floor or ground surface. The inside handrail on switch-back or dogleg ramps shall always be continuous. The ends of handrails shall be either rounded or returned smoothly to floor, wall or post. Handrails projecting from a wall shall have a space of 1½ inches (38 mm) between the wall and the handrail. Handrails may be located in a recess if the recess is a maximum of 3 inches (76 mm) deep and extends at least 18 inches (457 mm) above the top of the rail. The grip portion shall not be less than 1¼ inches (32 mm) nor more than 1½ inches (38 mm) in cross-sectional nominal dimension or the shape shall provide an equivalent gripping surface, and all surfaces shall be smooth with no sharp corners. Handrails shall not rotate within their fittings. Any wall or other surface adjacent to the handrail shall be free of sharp or abrasive elements. Edges shall have a minimum radius of 1⁄8 inch (3 mm).

Exceptions:

1. Handrails at ramps immediately adjacent to fixed seating in assembly areas are not required.

2. Curb ramps do not require handrails.

1133B.5.5.1.1 Ramp handrails. In existing buildings or facilities, where the extension of the handrail in the direction of the ramp run would create a hazard, the extension on the handrail may be turned 90 degrees to the run of the ramp.

1133B.5.6 Wheel guides. Where the ramp surface is not bounded by a wall, the ramp shall comply with Section 1133B.5.6.1 or 1133B.5.6.2.

1133B.5.6.1 A guide curb a minimum of 2 inches (51 mm) in height shall be provided at each side of the ramp; or

1133B.5.6.2 A wheel guide rail shall be provided, centered 3 inches (76 mm) plus or minus 1 inch (25 mm) above the surface of the ramp.

1133B.5.7 Guards. Ramps more than 30 inches (762 mm) above the adjacent ground shall be provided with guards that comply with Section 1013. Such guards shall be continuous from the top of the ramp to the bottom of the ramp.

1133B.5.8 Outdoor ramps. Outdoor ramps and their approaches shall be designed so that water will not accumulate on walking surfaces.

1133B.6 Aisles.

1133B.6.1 General. Every portion of every building in which are installed seats, tables, merchandise, equipment or similar materials shall be provided with aisles leading to an exit.

1133B.6.2 Width. Every aisle shall not be less than 36 inches (914 mm) wide if serving only one side, and not less than 44 inches (1118 mm) wide if serving both sides.

1133B.7 Walks and sidewalks.

1133B.7.1 Continuous surface. Walks and sidewalks subject to these regulations shall have a continuous common surface, not interrupted by steps or by abrupt changes in level exceeding ½ inch (12.7 mm) (see Section 1133B.7.4), and shall be a minimum of 48 inches (1219 mm) in width. If a walk or sidewalk has less than 60 inch (1525 mm) clear width, then passing spaces at least 60 inches by 60 inches (1525 mm by 1525 mm) shall be located at reasonable intervals not to exceed 200 feet (61 m). A T-intersection is an acceptable passing place. Surfaces shall be slip resistant as follows:

Exception: When, because of right-of-way restrictions, natural barriers or other existing conditions, the enforcing agency determines that compliance with the 48-inch (1219 mm) clear sidewalk width would create an unreasonable hardship, the clear width may be reduced to 36 inches (914 mm).

1133B.7.1.1 Slopes less than 6 percent. Surfaces with a slope of less than 6 percent gradient shall be at least as slip resistant as that described as a medium salted finish.

1133B.7.1.2 Slopes 6 percent or greater. Surfaces with a slope of 6 percent gradient shall be slip-resistant.

1133B.7.1.3 Surface cross slopes. Surface cross slopes shall not exceed $\frac{1}{4}$ inch (6 mm) per foot except when the enforcing agency finds that due to local conditions it creates an unreasonable hardship, the cross slope shall be increased to a maximum of $\frac{1}{2}$ inch (12.7 mm) per foot for distances not to exceed 20 feet (6096 mm) (4.16%).

Exception: When, because of right-of-way restrictions, natural barriers or other existing conditions, the enforcing agency determines that compliance with the 48-inch (1219 mm) clear sidewalk.

1133B.7.2 Gratings. Walks, sidewalks and pedestrian ways shall be free of gratings whenever possible. For gratings located in the surface of any of these areas, grid openings in gratings shall be limited to $\frac{1}{2}$ inch (12.7 mm) in the direction of traffic flow.

Exceptions:

1. Where the enforcing agency determines that compliance with this section would create an unreasonable hardship, an exception may be granted when equivalent facilitation is provided.
2. This section shall not apply in those conditions where, due to legal or physical constraints, the site of the project will not allow compliance with these building standards or equivalent facilitation without creating an unreasonable hardship. See Section 109.1.5.

1133B.7.3 Five-percent gradient. When the slope in the direction of travel of any walk exceeds one unit vertical to 20 units horizontal (5-percent gradient), it shall comply with the provisions of Section 1133B.5.

1133B.7.4 Changes in level. Abrupt changes in level along any accessible route shall not exceed $\frac{1}{2}$ inch (12.7 mm). When changes in level do occur, they shall be beveled with a slope no greater than one unit vertical to 2 units horizontal (50 percent), except that level changes not exceeding $\frac{1}{4}$ inch (6 mm) may be vertical.

When changes in level greater than $\frac{1}{2}$ inch (12.7 mm) are necessary, they shall comply with the requirements for curb ramps. See Section 1127B.5.

1133B.7.5 Level areas. Walks shall be provided with a level area not less than 60 inches by 60 inches (1524 mm by 1524 mm) at a door or gate that swings toward the walk, and not less than 48 inches wide by 44 inches (1219 mm by 1118 mm) deep at a door or gate that swings away from the walk. Such walks shall extend 24 inches (610 mm) to the side of the strike edge of a door or gate that swings toward the walk. (For example, see Figure 11B-26B.)

1133B.7.6 Walks with continuous gradients. All walks with continuous gradients shall have level areas at least 5 feet (1524 mm) in length at intervals of at least every 400 feet (121 920 mm).

1133B.8 Hazards.

1133B.8.1 Warning curbs. Abrupt changes in level, except between a walk or sidewalk and an adjacent street or driveway, exceeding 4 inches (102 mm) in a vertical dimension, such as at planters or fountains located in or adjacent to

walks, sidewalks or other pedestrian ways, shall be identified by curbs projecting at least 6 inches (152 mm) in height above the walk or sidewalk surface to warn the blind of a potential drop off.

When a guard or handrail is provided, no curb is required when a guide rail is provided centered 3 inches (76 mm) plus or minus 1 inch (25 mm) above the surface of the walk or sidewalk, the walk is 5 percent or less gradient or no adjacent hazard exists.

1133B.8.2 Overhanging obstructions. Any obstruction that overhangs a pedestrian way shall be a minimum of 80 inches (2032 mm) above the walking surface as measured from the bottom of the obstruction. Where a guy support is used parallel to a path of travel, including, but not limited to sidewalks, a guy brace, sidewalk guy or similar device shall be used to prevent an overhanging obstruction as defined (see Figure 11B-28).

Hazards such as drop-offs adjacent to walkways or overhanging obstructions can be dangerous to persons with sight problems. This section addresses these situations.

1133B.8.3 Detectable warnings at transit boarding platforms. See Section 1121B.3.1, Item 8(a).

1133B.8.4 Detectable directional texture at boarding platforms. See Section 1121B.3.1, Item 8(b).

1133B.8.5 Detectable warnings at hazardous vehicular areas. If a walk crosses or adjoins a vehicular way, and the walking surfaces are not separated by curbs, railings or other elements between the pedestrian areas and vehicular areas, the boundary between the areas shall be defined by a continuous detectable warning which is 36 inches (914 mm) wide, complying with Section 1121B.3.1, Item 8(a).

Only approved DSA-AC detectable warning products and directional surfaces shall be installed as provided in the California Code of Regulations (CCR), Title 24, Part 1, Articles 2, 3 and 4. Refer to CCR Title 24, Part 12, Chapters 12-11A and B, for building and facility access specifications for product approval for detectable warning products and directional surfaces.

Detectable warning products and directional surfaces installed after January 1, 2001, shall be evaluated by an independent entity, selected by the Department of General Services, Division of the State Architect—Access Compliance, for all occupancies, including transportation and other outdoor environments, except that when products and surfaces are for use in residential housing, evaluation shall be in consultation with the Department of Housing and Community Development. See Government Code Section 4460.

1133B.8.6 Protruding objects.

1133B.8.6.1 General. Objects projecting from walls (for example, telephones), with their leading edges between 27 inches (686 mm) and 80 inches (2032 mm) above the finished floor, shall protrude no more than 4 inches (102 mm) into walks, halls, corridors, passageways or aisles. Objects mounted with their leading edges at or below 27 inches (686 mm) above the finished floor may protrude

any amount. Free-standing objects mounted on posts or pylons may overhang 12 inches (305 mm) maximum from 27 inches (686 mm) to 80 inches (2032 mm) above the ground or finished floor. Protruding objects shall not reduce the clear width of an accessible route or maneuvering space. See Figure 11B-7A.

1133B.8.6.2 Head room. *Walks, halls, corridors, passageways, aisles or other circulation spaces shall have 80 inches (2032 mm) minimum clear head room. If vertical clearance of an area adjoining an accessible route is reduced to less than 80 inches (nominal dimension), a barrier to warn blind or visually impaired persons shall be provided. See Figures 11B-7A and 11B-7C.*

1133B.8.6.3 Free-standing signs. *Wherever signs mounted on posts or pylons protrude from the posts or pylons and the bottom edge of the sign is at less than 80 inches (2032 mm) above the finished floor or ground level, the edges of such signs shall be rounded or eased and the corners shall have a minimum radius of 0.125 inches (3.2 mm).*

Division IV—ACCESSIBILITY FOR EXISTING BUILDINGS

SECTION 1134B ACCESSIBILITY FOR EXISTING BUILDINGS

1134B.1 Scope. The provisions of this division apply to renovation, structural repair, alteration and additions to existing buildings, including those identified as historic buildings. This division identifies minimum standards for removing architectural barriers, and providing and maintaining accessibility to existing buildings and their related facilities.

1134B.2 General. All existing buildings and facilities, when alterations, structural repairs or additions are made to such buildings or facilities, shall comply with all provisions of Division I—New Buildings, except as modified by this division. These requirements shall apply only to the area of specific alteration, structural repair or addition and shall include those areas listed below:

1134B.2.1 A primary entrance to the building or facility and the primary path of travel to the specific area of alteration, structural repair or addition, and sanitary facilities, drinking fountains, signs and public telephones serving the area.

Exceptions:

1. When the total construction cost of alterations, structural repairs or additions does not exceed a valuation threshold of \$50,000, based on January 1981, “ENR US20 Cities” Average Construction Cost Index of 3372.02 (Engineering News Record, McGraw Hill Publishing Company), and the enforcing agency finds that compliance with this code creates an unreasonable hardship, compliance shall be limited to the actual work of the project. The enforcing agency shall annually update the valuation threshold to a current amount based on the increase in the index since the last figure used. (For example, the January 2006 amount is \$113,586.07.) For purposes of this exception, an unreasonable hardship exists where the cost of providing an accessible entrance, path of travel, sanitary facilities, public phones and drinking fountains is disproportionate to the cost of the project; that is, where it exceeds 20 percent of the cost of the project without these features. Where the cost of alterations necessary to make these features fully accessible is disproportionate, access shall be provided to the extent that it can be without incurring disproportionate cost. In choosing which accessible elements to provide, priority should be given to those elements that will provide the greatest access in the following order:

- 1.1. An accessible entrance;
- 1.2. An accessible route to the altered area;
- 1.3. At least one accessible restroom for each sex;
- 1.4. Accessible telephones;
- 1.5. Accessible drinking fountains; and

- 1.6. When possible, additional accessible elements such as parking, storage and alarms.

The obligation to provide access may not be evaded by performing a series of small alterations to the area served by a single path of travel if those alterations could have been performed as a single undertaking. If an area has been altered without providing an accessible path of travel to that area, and subsequent alterations of that area or a different area on the same path of travel are undertaken within three years of the original alteration, the total cost of alterations to the areas on that path of travel during the preceding three-year period shall be considered in determining whether the cost of making that path of travel accessible is disproportionate. Only alterations undertaken after January 26, 1992, shall be considered in determining if the cost of providing an accessible path of travel is disproportionate to the overall cost of the alterations.

2. Certain types of privately funded, multistory buildings and facilities were formerly exempt from accessibility requirements above and below the first floor under this code, but as of the effective date of this regulation are no longer exempt due to more restrictive provisions in the federal Americans with Disabilities Act. In alteration projects involving buildings and facilities previously approved and built without elevators, areas above and below the ground floor are subject to the 20-percent disproportionality provisions described in Exception 1, above, even if the value of the project exceeds the valuation threshold in Exception 1. The types of buildings and facilities are:

- 2.1. Office buildings and passenger vehicle service stations of three stories or more and 3,000 or more square feet (279 m²) per floor.
- 2.2. Offices of physicians and surgeons.
- 2.3. Shopping centers.
- 2.4. Other buildings and facilities three stories or more and 3,000 or more square feet (279 m²) per floor if a reasonable portion of services sought and used by the public is available on the accessible level.

For the general privately funded multistory building exception applicable to new construction and alterations, see Section 1103B.1, Exception 2.

The elevator exception set forth in this section does not obviate or limit in any way the obligation to comply with the other accessibility requirements in this code. For example, floors above or below the accessible ground floor must meet the requirements of this section except for elevator service. If toilet or bathing facilities are provided on a level not served by an elevator, then toilet or bathing facilities must be provided on the accessible ground floor.

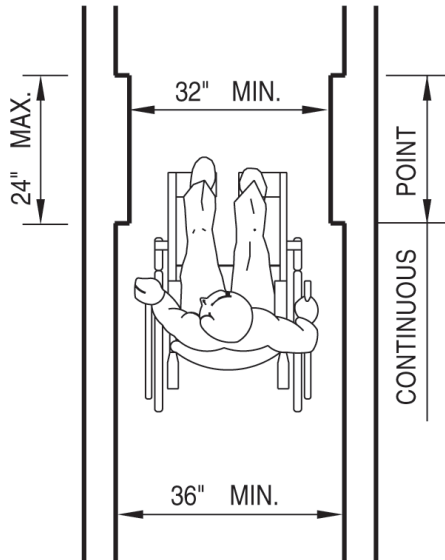

FIGURE 11B-10—MINIMUM CLEAR WIDTH FOR SINGLE WHEELCHAIR

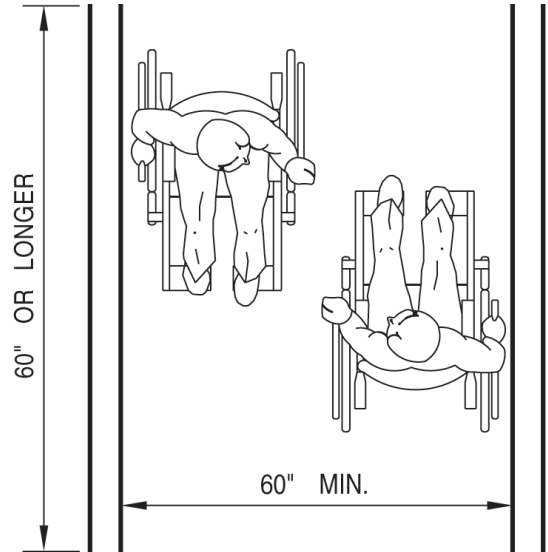
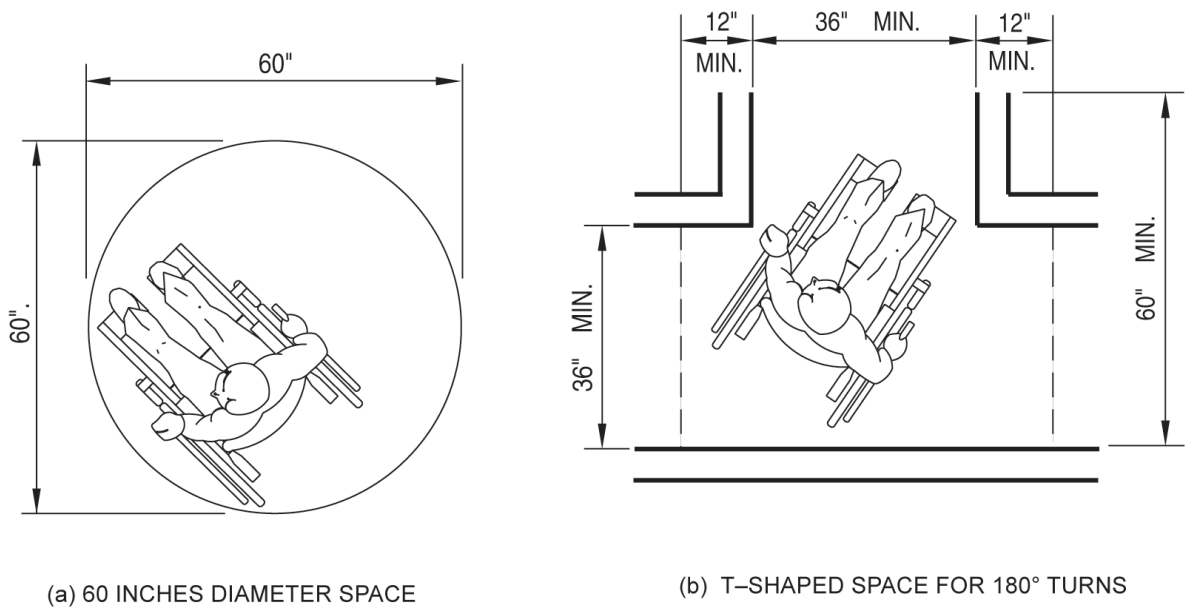

FIGURE 11B-11—MINIMUM CLEAR WIDTH FOR TWO WHEELCHAIRS



(a) 60 INCHES DIAMETER SPACE

(b) T-SHAPED SPACE FOR 180° TURNS

THESE DIAGRAMS ILLUSTRATE THE SPECIFIC REQUIREMENTS OF THESE REGULATIONS AND ARE INTENDED ONLY AS AN AID FOR BUILDING DESIGN AND CONSTRUCTION.

FIGURE 11B-12—WHEELCHAIR TURNING SPACE

**CALIFORNIA BUILDING CODE – MATRIX ADOPTION TABLE
CHAPTER 12 – INTERIOR ENVIRONMENT**

Adopting Agency	BSC	SFM	HCD			DSA		OSHDP				CSA	DHS	AGR	DWR	CEC	CA	SL	SLC
			1	2	1/AC	AC	SS	1	2	3	4								
Adopt Entire Chapter		X					X												
Adopt Entire Chapter as amended (amended sections listed below)	X		X	X				X	X	X	X								
Adopt only those sections that are listed below												X	X	X		X	X		
Chapter / Section	Codes																		
1203.1	CA							X	X	X	X								
1203.3.1.1	CA																X		
1203.3.2	IBC		X	X															
1203.3.2 Item 4	CA															X			
1203.3.2 Exc. 6	CA																X		
1203.4	IBC		X	X															
1203.5	IBC		X	X															
1204.1w/Excs.	CA		X	X				X	X	X	X								
1205.1	IBC		X	X															
1205.6	CA	X																	
1207	CA		X																
1208.1	IBC		X																
1208.2	CA							X	X	X	X								
1208.2.1	CA							X	X	X	X								
1208.4	IBC		X																
1209.1.1	CA																	X	
1211	CA		X	X															
1224	CA							X											
1225	CA								X										
1226	CA									X									
1227	CA										X								
1230	CA											X							
1231	CA											X							
1235	CA												X						
1236	CA												X						
1237	CA												X						
1240	CA													X					
1241	CA													X					
1242	CA													X					
1243	CA													X					
1250	CA																X		
1251	CA																X		
1252	CA																X		
1253	CA																X		
1254	CA																X		

The ♦ designation indicates that the Office of the State Fire Marshal's adoption of this chapter or individual sections is applicable to structures subject to HCD 1 and/or HCD 2 or DSA-SS.

1241.1.2 Buildings used for the temporary storage of animal carcasses, packinghouse wastes and other products before transportation to a licensed rendering plant shall be of sound construction and shall be of such construction as to prevent the entrance or harboring of vermin.

1241.1.3 The floors, walls, ceilings, partitions and doors shall be of such material, construction and finish as to make them readily cleanable.

1241.1.4 The area for the cleaning and sanitizing of vehicles shall be provided with adequate live steam or hot water, producing a temperature of at least 180°F (82°C), or other method for sanitizing vehicles.

1241.1.5 Facilities shall be provided for the holding and disposal of solid waste resulting from the cleaning operation. Such facilities shall be accessible and easily cleaned and so constructed as to prevent the entrance or harborage of vermin, flies and other insects.

1241.1.6 The cleaning and sanitizing of vehicles shall be done on a slab of concrete or other material approved by the Department, which is sloped to drains so as to permit the rapid runoff of water.

1241.1.7 Carcasses and packinghouse waste. The unloading slab shall be of sufficient size to hold all animal carcasses and packinghouse waste material, be constructed of concrete or other material approved by the Department and sloped to drains so as to permit the rapid runoff of water.

1241.2 Floors. Floors of rooms in which carcasses and packinghouse wastes are received or stored shall be graded to permit runoff of water with no standing water. In new construction and in renovated buildings where floors are to be resurfaced, the pitch shall not be less than 1/4 inch per foot (2 percent) to drains.

1241.3 Lavatories and toilets. Modern lavatory accommodations, including running hot and cold water, shall be provided except where the Department determines that they are not necessary.

**SECTION 1242 [AGR]
RENDERERS**

1242.1 General construction.

1242.1.1 Separation from other businesses. Every licensed rendering establishment shall be separate and distinct from any establishments in which any meat, meat byproducts, poultry, or poultry byproducts are handled and from any other business at the discretion of the Department.

1242.1.2 The cleaning and sanitizing of vehicles shall be done on a slab of concrete or other material approved by the Department; which is sloped to drains so as to permit the rapid runoff of water.

**SECTION 1243 [AGR]
HORSEMEAT AND PET FOOD ESTABLISHMENTS**

1243.1 Scope. In the event of specific conflict between the provisions of Title 24 and federal regulations, the federal regula-

tions shall take precedence in establishments under federal inspection.

1243.2 General.

1243.2.1 Facilities for program employees. Office space, including light and heat shall be provided by official establishments for the inspector and other program employees. The office space shall be conveniently located and adequately ventilated, heated, cooled, and provided with adequate desk and file space.

1243.2.2 Final inspection places.

1243.2.2.1 Final inspection places shall, by size, rail arrangement and other equipment, prevent contamination of edible carcasses or parts by inedible carcasses or parts.

1243.2.2.2 Floors. The floors shall be of such construction as to facilitate the maintenance of sanitary conditions and shall have drainage connections. When the final inspection place is part of a larger floor, it shall be separated from the rest of the floor by a curb, railing or otherwise.

1243.2.3 Docks and receiving rooms. Docks and receiving rooms shall be provided.

1243.2.4 The floors, walls, ceilings, partitions, posts, doors and other parts of all structures shall be of such material, construction and finish as will make them readily and thoroughly cleanable. The floors shall be kept watertight.

1243.2.5 Rails. Rails shall be located and passageway space provided, so that exposed product does not come in contact with post, walls and other fixed parts of the building, or with barrels, boxes and other containers trafficked through holding and operation areas.

1243.2.6 The rooms and compartments used for edible products shall be separated and distinct from those used for inedible products.

1243.2.7 The rooms and compartments in which any product is prepared or handled shall be free from objectionable odor.

1243.2.8 Precaution shall be taken to exclude flies, rats, mice and other vermin from official establishments.

1243.2.9 The outer premises of horsemeat and pet food establishments shall meet the requirements of Section 1240.1.5.

1243.3 Lighting. There shall be light and ventilation for all rooms and compartments.

1243.4 Sanitary facilities and accommodations. Sanitary facilities and accommodations shall be furnished by every official establishment.

1243.4.1 Dressing rooms and toilet rooms shall be provided in each establishment and shall be ample in size and readily accessible. They shall be separated from the rooms and compartments in which products are prepared, stored or handled. Where both sexes are employed, separate facilities shall be provided.

1243.4.2 Lavatories, including running hot and cold water, shall be placed in or adjacent to toilet and urinal rooms and at other places in the establishment to assure cleanliness of all persons handling any product.

1243.4.3 Facilities shall be provided for cleansing and disinfecting utensils.

1243.5 Catch basins. All catch basins on the premises shall be of such construction and location to ensure they are kept clean and odorless. Catch basins shall not be located in department where any product is prepared, handled or stored.

1243.6 Final inspection space. Such spaces shall be equipped with hot water and a lavatory.

SECTION 1244
Reserved

SECTION 1245
Reserved

SECTION 1246
Reserved

SECTION 1247
Reserved

SECTION 1248
Reserved

SECTION 1249
Reserved

SECTION 1250 [CA]
PHARMACIES

1250.1 Application. This section applies to pharmacies listed in Section 104.1 regulated by the Department of Consumer Affairs.

1250.2 Restrooms. A pharmacy shall maintain a readily accessible restroom. The restroom shall contain a toilet and washbasin supplied with running water.

1250.3 Sink. All pharmacies shall be equipped with a sink within the pharmacy for pharmaceutical purposes. The sink shall be supplied with hot and cold running water.

1250.4 Compounding area for parenteral solutions. The pharmacy shall have a designated area for the preparation of sterile products for dispensing which shall:

1. In accordance with Federal Standard 209 (b), Clean Room and Work Station Requirements, Controlled Environment as approved by the Commission, Federal Supply Service, General Service Administration meet standards for Class 100 HEPA (high efficiency particulate air) filtered air such as laminar airflow hood or clean room.

2. Have nonporous and cleanable surfaces, ceilings and ceiling tiles, walls, floors and floor coverings.
3. The pharmacy shall be arranged in such a manner that the laminar-flow hood is located in an area which is exposed to minimal traffic flow, and is separate from any area used for bulk storage of items not related to the compounding of parenteral solutions.

There shall be sufficient space, well separated from the laminar-flow hood area for the storage of bulk materials, equipment and waste materials.

4. A sink with hot and cold running water must be within the parenteral solution compounding area or adjacent to it.
5. Any pharmacy that compounds sterile injectable products from one or more nonsterile ingredients must compound the medication in one of the following environments:

- 5.1 An ISO class 5 laminar airflow hood within an ISO class 7 cleanroom. The cleanroom must have a positive air pressure differential relative adjacent areas.
- 5.2 An ISO class 5 cleanroom.
- 5.3 A barrier isolator that provides an ISO class 5 environment for compounding.

Note: For additional pharmacy mechanical standard requirements, see Chapter 5, California Mechanical Code.

SECTION 1251 [CA]
VETERINARY FACILITIES

1251.1 All premises where veterinary medicine, veterinary dentistry or veterinary surgery is being practiced, and all instruments, apparatus and apparel used in connection with those practices, shall be kept clean and sanitary at all times and shall conform to the standards of this section.

1251.2 Indoor lighting for halls, wards, reception areas and examining and surgical rooms shall be adequate for their intended purpose. All surgical rooms shall be provided with emergency lighting.

1251.3 A veterinary facility where animals are housed shall contain the following:

1. A reception room and office, or a combination of the two.
2. An examination room separate from other areas of the facility and of sufficient size to accommodate the doctor, assistant, patient and client.
3. A surgery room separate and distinct from all other rooms.
4. **Housing.** In those veterinary hospitals where animals are retained for treatment or hospitalization, the following shall be provided:
 - 4.1. Separate compartments, one for each animal, maintained in a sanitary manner so as to assure comfort.
 - 4.2. Facilities allowing for the effective separation of contagious and noncontagious cases.

4.3. Exercise runs which provide and allow effective separation of animals and their waste products.

Note: Where animals are kept in clinics for 24 hours or more, walking the animal meets this requirement.

1251.4 Practice management.

1251.4.1 Veterinary facilities shall maintain a sanitary environment to avoid sources and transmission of infection. This is to include the proper routine of disposal of waste materials and proper sterilization or sanitation of all equipment used in diagnosis or treatment.

1251.4.2 Fire precautions shall meet the requirements of local and state fire prevention codes.

1251.4.3 The temperature and ventilation of the facility shall be maintained so as to assure the comfort of all patients.

1251.4.4 The veterinary facility must have the capacity to render adequate diagnostic radiological services, either in the hospital or through other commercial facilities. Radiological procedures shall be in accordance with state public health standards.

1251.4.5 Sanitary methods for the disposal of deceased animals shall be provided and maintained. Where the owner of a deceased animal has not given the veterinarian authorization to dispose of the animal, the veterinarian shall be required to retain the carcass in a freezer for at least 14 days.

**SECTION 1252 [CA]
BARBER COLLEGES AND SHOPS**

1252.1 Barber college floors. Floors of barber colleges shall be covered with hardwood, linoleum, asphalt tile or some other washable and nonporous material other than paint.

1252.2 Barber shop floors. Floors of barber shops shall be covered with hardwood, linoleum, asphalt tile, carpeting or some other washable material other than paint.

1252.3 Barber shop washbasin(s) and lavatory(ies). A barber shop owner shall provide washbasin(s) or lavatory(ies) within the working area of the barber shop.

1252.4 Minimum barber shop size. A barber shop shall be a minimum of 8 feet (2438 mm) wide, 8 feet (2438 mm) long, with an 8-foot (2438 mm) ceiling.

1252.5 Barber college premises. In a college of barbering, the room for practical work and demonstrations shall be at least 14 feet (4267 mm) wide for one row of barber chairs and shall be at least 20 feet (6096 mm) wide for two rows of chairs.

**SECTION 1253 [CA]
SCHOOLS OF COSMETOLOGY,
COSMETOLOGICAL ESTABLISHMENTS AND
SATELLITE CLASSROOMS**

1253.1 Floor space.

1253.1.1 Schools of cosmetology. The minimum floor space in any school of cosmetology premises shall be 3,000 square feet (279 m²), not less than 2,000 square feet (185.8 m²) of which shall be provided for the working, practice and classroom areas.

Exception: When the average daily attendance for either day or night school in a school of cosmetology exceeds 50 students for a period of three months, an additional 30 square feet (2.8 m²) of floor space shall be required for each additional student after the first 50, which shall be provided for the working, practice and classroom areas.

1253.1.2 Schools of electrology. The minimum floor space in any school of electrology premises shall be 1,000 square feet (93 m²), not less than 600 square feet (55.7 m²) of which shall be provided for the working, practice and classroom areas.

Exception: When the average daily attendance for either day or night school of electrology exceeds 15 students, an additional 30 square feet (2.8 m²) of floor space shall be required for each additional student after the first 15, which shall be provided for working, practice and classroom areas.

1253.1.3 Satellite classrooms. The minimum floor space in any satellite classroom of a school of cosmetology or electrology shall be 1,000 square feet (93 m²).

Exception: For each additional student after the first 50, an additional 20 square feet (1.9 m²) of floor space shall be required.

1253.2 Floor finish. The floors in the toilet area of each school and establishment shall be of nonabsorbent material.

1253.3 Ceiling height. The minimum ceiling height of the practice and classroom areas of school premises shall be at least 9 feet (2743 mm) in height.

**SECTION 1254 [CA]
ACUPUNCTURE OFFICES**

1254.1 Acupuncture offices. Every acupuncture office shall have a readily accessible bathroom facility which shall be maintained in a clean and sanitary condition at all times. In addition, there shall be a sink with hot and cold running water in or near each treatment room.

3. The application of a new protective coating over an existing spray polyurethane foam roofing system shall be permitted without tear-off of existing roof coverings.

1510.4 Roof recovering. Where the application of a new roof covering over wood shingle or shake roofs creates a combustible concealed space, the entire existing surface shall be covered with gypsum board, mineral fiber, glass fiber or other approved materials securely fastened in place.

1510.5 Reinstallation of materials. Existing slate, clay or cement tile shall be permitted for reinstallation, except that damaged, cracked or broken slate or tile shall not be reinstalled. Existing vent flashing, metal edgings, drain outlets, collars and metal counterflashings shall not be reinstalled where rusted, damaged or deteriorated. Aggregate surfacing materials shall not be reinstalled.

1510.6 Flashings. Flashings shall be reconstructed in accordance with approved manufacturer's installation instructions. Metal flashing to which bituminous materials are to be adhered shall be primed prior to installation.

**SECTION 1511 [DSA-SS & OSHPD 1, 2 and 4]
SEISMIC ANCHORAGE OF SLATE SHINGLE, CLAY
AND CONCRETE TILE ROOF COVERINGS**

1511.1 Fasteners. Nails shall be long enough to penetrate into the sheathing $\frac{3}{4}$ inch (19 mm). Where sheathing is less than $\frac{3}{4}$ inch (19 mm) in thickness, nails shall be driven into supports, unless nails with ring shanks are used.

All fasteners shall be corrosion resistant and fabricated of copper, stainless steel or brass, or shall have a hot-dipped galvanized coating not less than 1.0 ounce of zinc per square foot (305 gm/m²).

Nails for slate shingles and clay or concrete tile shall be copper, brass or stainless steel with gage and length per common ferrous nails.

1511.2 Wire. Wire for attaching slate shingles and clay or concrete tile shall be copper, brass or stainless steel capable of supporting four times the weight of tile.

Wire supporting a single tile or shingle shall not be smaller than $\frac{1}{16}$ inch (1.6 mm) in diameter. Continuous wire ties supporting more than one tile shall not be smaller than 0.084 inch (2 mm) in diameter.

1511.3 Metal strips. Metal strips for attaching slate shingles and clay or concrete tile shall be copper, brass or stainless steel capable of supporting four times the weight of tile.

1511.4 Clay or concrete tiles. Clay or concrete tile shall be installed in accordance with Table 1507.3.7 and as described herein.

1. On wood roofs or roofs of other material to which wood strips are secured, every cover or top tile when fastened with nails shall be nailed directly into $1\frac{1}{4}$ inches (32 mm) sound grain soft wood strips of sufficient height to support the tile.

Pan or bottom tiles shall be nailed directly to the roof sheathing or to wood strips. Wood strips shall be secured

to the roof by nails spaced not over 12 inches (305 mm) apart.

2. On concrete roofs, wires shall be secured in place by wire loops embedded into the concrete not less than 2 inches (51 mm). The wire loops shall be spaced not more than 36 inches (914 mm) on center parallel to the eaves, and spaced vertically to allow for the minimum 3 inches (76 mm) lapping of the tile.
3. Where continuous ties of twisted wire, interlocking wires or metal strips extending from the ridge to eave are used to attach tile, the ties shall be attached to the roof construction at the ridge, eave and at intervals not exceeding 10 feet (3048 mm) on center. The ties within 2 feet (610 mm) of the rake shall be attached at intervals of 5 feet (1524 mm).

Attachment for continuous ties shall be nails, screws, staples or approved clips of the same material as the ties and shall not be subjected to withdrawal forces. Attachments for continuous ties shall have an allowable working stress shear resistance of not less than twice the dead weight of the tile tributary to the attachment, but not less than 300 pounds (136 kg).

4. Tile with projecting anchor lugs at the bottom of the tiles shall be held in position by means of 1-inch by 2-inch (25 mm by 51 mm) wood stripping nailed to the roof sheathing over the underlay.
5. Clay or concrete tile on roofs with slopes exceeding 24 units vertical in 12 units horizontal (200-percent slope) shall be attached as required for veneer in Chapter 14. The nose of all tiles shall be securely fastened.
6. Clay or concrete tile shall have a minimum of two fasteners per tile. Tiles that are 8 inches (203 mm) in width or less are permitted to be fastened at the center of the head with one fastener per tile.
7. Interlocking clay or concrete tile shall have a minimum of one nail near center of head or two wire ties per tile.

1511.5 Slate shingles. Slate shingles on roofs with slopes exceeding 24 units vertical in 12 units horizontal (200-percent slope) shall be attached as required for veneer per Chapter 14.

1511.6 Alternative design. An alternative design of the fastening system used to resist seismic loads is permitted, provided that an engineering analysis or test report based on cyclic testing is provided to the enforcement agency.

The fastening system shall be designed to resist seismic forces per ASCE 7, Section 13.3. Testing of alternative fastening system shall comply with ASCE 7, Section 13.2.5.

