

REVISION RECORD FOR THE STATE OF CALIFORNIA

SUPPLEMENT

January 1, 2009

2007 Title 24, Part 2, California Building Code

**PLEASE NOTE: The date of this supplement is for identification purposes only.
See the History Note Appendix for the adoption and effective dates of the provisions.**

It is suggested that the section number as well as the page number be checked when inserting this material and removing the superseded material. In case of doubt, rely on the section numbers rather than the page numbers because the section numbers must run consecutively.

It is further suggested that the material be retained with this revision record sheet so that the prior wording of any section can be easily ascertained.

Please keep the removed pages with this revision page for future reference.

Note

Due to the fact that the application date for a building permit establishes the California Building Standards code provisions that are effective at the local level, which apply to the plans, specifications, and construction for that permit, it is strongly recommended that the removed pages be retained for historical reference.

Volume 1

Remove Existing Pages

v and vi
3 through 8
13 through 16
21 through 28
31 and 32
35 through 44
47 through 50
53 through 56
63 and 64
67 and 68
75 and 76
91 and 92
109 through 114

Insert New Pages

v and vi
3 through 8
13 through 16
21 through 28
31 and 32
35 through 44
47 through 50
53 through 56
63 and 64
67 and 68
75 and 76
91 and 92
109 through 114

(continued)

Remove Existing Pages

121 and 122
125 through 130
133 through 136
139 and 140
149 through 152
157 through 160
163 and 164
189 and 190
235 through 238
243 and 244
247 through 250
253 through 256
259 and 260
273 through 278
285 and 286
289 through 292
297 through 302
305 and 306
311 and 312
315 through 318
325 and 326
335 through 352
355 through 364
367 and 368
391 and 392

415 through 420
423 through 472
477 through 480
519 through 522
529 through 532
541 and 542
545 through 548
555 through 558
563 through 568
571 through 574
577 through 582
585 through 588
593 through 598
651 and 652
673 and 674

Insert New Pages

121 and 122
125 through 130
133 through 136
139 and 140
149 through 152
157 through 160
163 and 164
189 and 190
235 through 238
243 and 244
247 through 250
253 through 256
259 and 260
273 through 278
285 and 286
289 through 292
297 through 302
305 and 306
311 and 312
315 through 318
325 and 326
335 through 352
355 through 364
367 and 368
391 and 392
404.1 and 404.2
415 through 420
423 through 472.2
477 through 480
519 through 522
529 through 532
541 and 542
545 through 548
555 through 558
563 through 568
571 through 574
577 through 582
585 through 588
593 through 598
651 and 652
673 and 674

California Code of Regulations, Title 24

California Agency Information Contact List

California Energy Commission

Energy Hotline (800) 772-3300
Building Efficiency Standards
Appliance Efficiency Standards
Compliance Manual/Forms

California State Lands Commission

Marine Oil Terminals (562) 499-6317

California State Library

Construction Standards (918) 445-9604

Corrections Standards Authority

Local Adult Jail Standards (916) 324-1914
Local Juvenile Facility Standards (916) 324-1914

Department of Consumer Affairs – Acupuncture Board

Office Standards (916) 445-3021

Department of Consumer Affairs – Board of Pharmacy

Pharmacy Standards (916) 574-7900

Department of Consumer Affairs – Bureau of Barbering and Cosmetology

Barber and Beauty Shop and
College Standards (916) 952-5210

Department of Consumer Affairs – Bureau of Home Furnishings and Thermal Insulation

Insulation Testing Standards (916) 574-2041

Department of Consumer Affairs – Structural Pest Control Board

Structural Standards (800) 737-8188

Department of Consumer Affairs – Veterinary Medical Board

Veterinary Hospital Standard (916) 263-2610

Department of Food and Agriculture

Meat and Poultry Packing Plant
Standards (916) 654-0509
Dairy Standards (916) 654-0773

Department of Health Services

Organized Camps Standards (916) 449-5661
Public Swimming Pools Standards (916) 449-5661
Asbestos Standards (510) 620-2874

Department of Housing and Community Development

Residential – Hotels, Motels, Apartments,
Single-Family Dwellings (916) 445-9471
Permanent Structures in Mobilehome and
Special Occupancy Parks (916) 445-9471
Factory-Built Housing, Manufactured
Housing and Commercial Modular (916) 445-3338
Mobilehomes – Permits and Inspections
Northern Region (916) 255-2501
Southern Region (951) 782-4420
Employee Housing Standards (916) 445-9471

Department of Water Resources

Gray Water Installations Standards (916) 651-9687

Division of the State Architect – Access Compliance

Access Compliance Standards (916) 445-8100

Division of the State Architect – Structural Safety

Public Schools Standards (916) 445-8100
Essential Services Building Standards (916) 445-8100

Office of Statewide Health Planning and Development

Hospital Standards (916) 440-8409
Skilled Nursing Facility Standards (916) 440-8409
Clinic Standards (916) 440-8409

Office of the State Fire Marshal

Code Development and Analysis (916) 445-8200
Fire Safety Standards (916) 445-8200
Fireplace Standards (916) 445-8200
Day Care Centers Standards (916) 445-8200
Exit Standards (916) 445-8200

(CALIFORNIA) CHAPTER 1

GENERAL CODE PROVISIONS

SECTION 101 GENERAL

101.1 Title. *These regulations shall be known as the California Building Code, may be cited as such and will be referred to herein as “this code.” The California Building Code is Part 2 of 12 parts of the official compilation and publication of the adoption amendment and repeal of building regulations to the California Code of Regulations, Title 24, also referred to as the California Building Standards Code. This part incorporates by adoption the 2006 International Building Code of the International Code Council with necessary California amendments.*

101.2 Purpose. *The purpose of this code is to establish the minimum requirements to safeguard the public health, safety and general welfare through structural strength, means of egress facilities, stability, access to persons with disabilities, sanitation, adequate lighting and ventilation and energy conservation; safety to life and property from fire and other hazards attributed to the built environment; and to provide safety to fire fighters and emergency responders during emergency operations.*

[DSA-AC] The purpose of this code is to ensure that barrier-free design is incorporated in all buildings, facilities, site work and other developments to which this code applies and to ensure that they are accessible to and usable by persons with disabilities.

101.3 Scope. *The provisions of this code shall apply to the construction, alteration, movement, enlargement, replacement, repair, equipment, use and occupancy, location, maintenance, removal and demolition of every building or structure or any appurtenances connected or attached to such buildings or structures throughout the State of California.*

101.3.1 Nonstate-regulated buildings, structures and applications. *Except as modified by local ordinance pursuant to Section 101.8, the following standards in the California Code of Regulations, Title 24, Parts 2, 3, 4, 5, 6, 9 and 10 shall apply to all occupancies and applications not regulated by a state agency.*

101.3.2 State-regulated buildings, structures and applications. *The model code, state amendments to the model code, and/or state amendments where there are no relevant model code provisions shall apply to the following buildings, structures, and applications regulated by state agencies as referenced in the Matrix Adoption Tables and as specified in Sections 102 through 114, except where modified by local ordinance pursuant to Section 101.8. When adopted by a state agency, the provisions of this code shall be enforced by the appropriate enforcing agency, but only to the extent of authority granted to such agency by the state legislature.*

Note: *See Preface to distinguish the model code provisions from the California provisions.*

1. *State-owned buildings, including buildings constructed by the Trustees of the California State*

University, and to the extent permitted by California laws, buildings designed and constructed by the Regents of the University of California, and regulated by the Building Standards Commission. See Section 102 for additional scope provisions.

2. *Local detention facilities regulated by the Corrections Standards Authority. See Section 103 for additional scope provisions.*
3. *Barbering, cosmetology or electrolysis establishments, acupuncture offices, pharmacies, veterinary facilities and structural pest control locations regulated by the Department of Consumer Affairs. See Section 104 for additional scope provisions.*
4. *Energy efficiency standards regulated by the California Energy Commission. See Section 105 for additional scope provisions.*
5. *Dairies and places of meat inspection regulated by the Department of Food and Agriculture. See Section 106 for additional scope provisions.*
6. *Organized camps, laboratory animal quarters, public swimming pools, radiation protection, commissaries serving mobile food preparation vehicles and wild animal quarantine facilities regulated by the Department of Health Services. See Section 107 for additional scope provisions.*
7. *Hotels, motels, lodging houses, apartment houses, dwellings, dormitories, condominiums, shelters for homeless persons, congregate residences, employee housing, factory-built housing and other types of dwellings containing sleeping accommodations with or without common toilets or cooking facilities. See Section 108.2.1.1 for additional scope provisions.*
8. *Accommodations for persons with disabilities in buildings containing newly constructed covered multifamily dwellings, new common use spaces serving existing covered multifamily dwellings, additions to existing buildings where the addition alone meets the definition of a “Covered multifamily dwelling” and common-use spaces serving covered multifamily dwellings which are regulated by the Department of Housing and Community Development. See Section 108.2.1.2 for additional scope provisions.*
9. *Permanent buildings and permanent accessory buildings or structures constructed within mobilehome parks and special occupancy parks regulated by the Department of Housing and Community Development. See Section 108.2.1.3 for additional scope provisions.*

10. Accommodations for persons with disabilities regulated by the Division of the State Architect. See Section 109.1 for additional scope provisions.
11. Public elementary and secondary schools, community college buildings and state-owned or state-leased essential service buildings regulated by the Division of the State Architect. See Section 109.2 for additional scope provisions.
12. Qualified historical buildings and structures and their associated sites regulated by the State Historical Building Safety Board with the Division of the State Architect. See Section 109.3 for additional scope provisions.
13. General acute care hospitals, acute psychiatric hospitals, skilled nursing and/or intermediate care facilities, clinics licensed by the Department of Public Health and correctional treatment centers regulated by the Office of Statewide Health Planning and Development. See Section 110 for additional scope provisions.
14. Applications regulated by the Office of the State Fire Marshal include, but are not limited to, the following in accordance with Section 111:
 - 14.1. Buildings or structures used or intended for use as an:
 - 14.1.1. Asylum, jail.
 - 14.1.2. Mental hospital, hospital, home for the elderly, children's nursery, children's home or institution, school or any similar occupancy of any capacity.
 - 14.1.3. Theater, dancehall, skating rink, auditorium, assembly hall, meeting hall, nightclub, fair building or similar place of assemblage where 50 or more persons may gather together in a building, room or structure for the purpose of amusement, entertainment, instruction, deliberation, worship, drinking or dining, awaiting transportation, or education.
 - 14.1.4. Small family day care homes, large family day care homes, residential facilities and residential facilities for the elderly, residential care facilities.
 - 14.1.5. State institutions or other state-owned or state-occupied buildings.
 - 14.1.6. High rise structures.
 - 14.1.7. Motion picture production studios.
 - 14.1.8. Organized camps.

- 14.1.9. Residential structures.
- 14.2. Tents, awnings or other fabric enclosures used in connection with any occupancy.
- 14.3. Fire alarm devices, equipment and systems in connection with any occupancy.
- 14.4. Hazardous materials, flammable and combustible liquids.
- 14.5. Public school automatic fire detection, alarm and sprinkler systems.
- 14.6. Wildland-urban interface fire areas.
15. Public libraries constructed and renovated using funds from the California Library Construction and Renovation Bond Act of 1988 and regulated by the State Librarian. See Section 112 for additional scope provisions.
16. Graywater systems regulated by the Department of Water Resources. See Section 113 for additional scope provisions.
17. For applications listed in Section 109.1 regulated by the Division of the State Architect—Access Compliance, outdoor environments and uses shall be classified according to accessibility uses described in Chapters 11A, 11B and 11C.
18. Marine Oil Terminals regulated by the California State Lands Commission. See Section 114 for additional scope provisions.

101.4 Appendices. Provisions contained in the appendices of this code shall not apply unless specifically adopted by a state agency or adopted by a local enforcing agency in compliance with Health and Safety Code Section 18938(b) for Building Standards Law, Health and Safety Code Section 17950 for State Housing Law and Health and Safety Code Section 13869.7 for Fire Protection Districts. See Section 101.8 of this code.

101.5 Referenced codes. The codes, standards and publications adopted and set forth in this code, including other codes, standards and publications referred to therein are, by title and date of publication, hereby adopted as standard reference documents of this code. When this code does not specifically cover any subject related to building design and construction, recognized architectural or engineering practices shall be employed. The National Fire Codes and the Fire Protection Handbook of the National Fire Protection Association are permitted to be used as authoritative guides in determining recognized fire prevention engineering practices.

101.6 Nonbuilding standards, orders and regulations. Requirements contained in the International Building Code, or in any other referenced standard, code or document, which are not building standards as defined in Health and Safety Code Section 18909, shall not be construed as part of the provisions of this code. For nonbuilding standards, orders and regulations, see other titles of the California Code of Regulations.

101.7 Order of precedence and use.

101.7.1 Differences. In the event of any differences between these building standards and the standard reference documents, the text of these building standards shall govern.

101.7.2 Specific provisions. Where a specific provision varies from a general provision, the specific provision shall apply.

101.7.3 Conflicts. When the requirements of this code conflict with the requirements of any other part of the California Building Standards Code, Title 24, the most restrictive requirements shall prevail.

101.8 City, county or city and county amendments, additions or deletions. The provisions of this code do not limit the authority of city, county or city and county governments to establish more restrictive and reasonably necessary differences to the provisions contained in this code pursuant to complying with Section 101.8.1. The effective date of amendments, additions or deletions to this code of cities, counties or city and counties filed pursuant to Section 101.8.1 shall be the date filed. However, in no case shall the amendments, additions or deletions to this code be effective any sooner than the effective date of this code.

Local modifications shall comply with Health and Safety Code Section 18941.5 for Building Standards Law, Health and Safety Code Section 17958 for State Housing Law or Health and Safety Code Section 13869.7 for Fire Protection Districts.

101.8.1 Findings and filings.

1. The city, county or city and county shall make express findings for each amendment, addition or deletion based upon climatic, topographical or geological conditions.

Exception: Hazardous building ordinances and programs mitigating unreinforced masonry buildings.

2. The city, county or city and county shall file the amendments, additions or deletions expressly marked and identified as to the applicable findings. Cities, counties, cities and counties, and fire departments shall file the amendments, additions or deletions, and the findings with the California Building Standards Commission at 2525 Natomas Park Drive, Suite 130, Sacramento, CA 95833.
3. Findings prepared by fire protection districts shall be ratified by the local city, county or city and county and filed with the California Department of Housing and Community Development at 1800 3rd Street, Room 260, Sacramento, CA 95814.

101.9 Effective date of this code. Only those standards approved by the California Building Standards Commission that are effective at the time an application for building permit is submitted shall apply to the plans and specifications for, and to the construction performed under, that permit. For the effective dates of the provisions contained in this code, see the History Note page of this code.

101.10 Availability of codes. At least one entire copy each of Titles 8, 19, 20, 24 and 25 with all revisions shall be maintained in the office of the building official responsible for the administration and enforcement of this code. See Health and Safety Code Section 18942(d)(1) and (2).

101.11 Format. This part fundamentally adopts the International Building Code by reference on a chapter-by-chapter basis. Such adoption is reflected in the Matrix Adoption Table of each chapter of this part. When the Matrix Adoption Tables make no reference to a specific chapter of the International Building Code such chapter of the International Building Code is not adopted as a portion of this code.

101.12 Validity. If any chapter, section, subsection, sentence, clause or phrase of this code is for any reason held to be unconstitutional, contrary to statute, exceeding the authority of the state as stipulated by statutes or otherwise inoperative, such decision shall not affect the validity of the remaining portion of this code.

SECTION 102 BUILDING STANDARDS COMMISSION

102.1 Specific scope of application of the agency responsible for enforcement, the enforcement agency and the specific authority to adopt and enforce such provisions of this code, unless otherwise stated.

1. State buildings for all occupancies.

Application—State buildings (all occupancies), including buildings constructed by the Trustees of the California State University and the Regents of the University of California where no state agency has the authority to adopt building standards applicable to such buildings.

Enforcing agency—State or local agency specified by the applicable provisions of law.

Authority cited—Health and Safety Code Section 18934.6.

Reference—Health and Safety Code, Division 13, Part 2.5, commencing with Section 18901.

2. University of California, California State Universities and California Community Colleges.

Application—Standards for lighting for parking lots and primary campus walkways at the University of California, California State Universities and California Community Colleges.

Enforcing agency—State or local agency specified by the applicable provisions of law.

Authority cited—Government Code Section 14617.

Reference—Government Code Section 14617.

3. Existing state-owned buildings, including those owned by the University of California and by the California State University.

Application—Building seismic retrofit standards including abating falling hazards of structural and nonstructural components and strengthening of building structures. See also Division of the State Architect.

Enforcing agency—State or local agency specified by the applicable provisions of law.

Authority cited—Health and Safety Code Section 16600.

Reference—Health and Safety Code Sections 16600 through 16604.

4. Unreinforced masonry-bearing wall buildings.

Application—Minimum seismic strengthening standards for buildings specified in Appendix Chapter A1 of the California Existing Building Code, except for buildings subject to building standards adopted pursuant to Health and Safety Code (commencing) with Section 17910.

Enforcing agency—State or local agency specified by the applicable provisions of law.

Authority cited—Health and Safety Code Section 18934.6.

Reference—Health and Safety Code Sections 18901 through 18949.

Enforcing agency—State or local agency specified by the applicable provisions of law.

Authority cited—Business and Professions Code Section 4933.

Reference—Business and Professions Code Sections 4928, 4928.1 and 4933.

3. Board of Pharmacy.

Application—Pharmacies.

Enforcing agency—State or local agency specified by the applicable provisions of law.

Authority cited—Business and Professions Code Section 4005.

Reference—Business and Professions Code Sections 4005, 4127.7 and 4201.

4. Veterinary Medical Board.

Application—Veterinary facilities.

Enforcing agency—State or local agency specified by the applicable provisions of law.

Authority cited—Business and Professions Code Section 4808.

Reference—Business and Professions Code Sections 4800, 4800.1, 4808 and 4809.5.

5. Structural Pest Control Board.

Application—structural pest control locations.

Enforcing agency—Structural Pest Control Board.

Authority cited—Business and Professions Code Section 8525.

Reference—Business and Professions Code Sections 8520, 8520.1 and 8525.

**SECTION 103
CORRECTIONS STANDARDS AUTHORITY**

103.1 Specific scope of application of the agency responsible for enforcement, the enforcement agency and the specific authority to adopt and enforce such provisions of this code, unless otherwise stated.

Application—Local detention facilities.

Enforcing agency—Corrections Standards Authority.

Authority cited—Penal Code Section 6030; Welfare and Institutions Code Sections 207.1, 210 and 885.

Reference—Penal Code Section 6030; Welfare and Institutions Code Sections 207.1, 210 and 885.

**SECTION 104
DEPARTMENT OF CONSUMER AFFAIRS**

104.1 Specific scope of application of the agency responsible for enforcement, the enforcement agency and the specific authority to adopt and enforce such provisions of this code, unless otherwise stated.

1. Board of Barbering and Cosmetology.

Application—Any establishment or mobile unit where barbering, cosmetology or electrolysis is being performed.

Enforcing agency—State or local agency specified by the applicable provisions of law.

Authority cited—Business and Professions Code Section 7312.

Reference—Business and Professions Code Sections 7303, 7303.1, 7312 and 7313.

2. Acupuncture Board.

Application—Acupuncture offices.

**SECTION 105
CALIFORNIA ENERGY COMMISSION**

105.1 Specific scope of application of the agency responsible for enforcement, enforcement agency, and the specific authority to adopt and enforce such provisions of this code, unless otherwise stated.

Application—All occupancies as specified in Title 24, Part 6, Section 100.

Enforcing agency—Local building department or the California Energy Commission.

Authority cited—Public Resources Code Sections 25213, 25402, 25920 and 25402.2.

Reference—Public Resources Code Sections 25001, 25213, 25402 and 25402.2.

**SECTION 106
DEPARTMENT OF FOOD AND AGRICULTURE**

106.1 *Specific scope of application of the agency responsible for enforcement, the enforcement agency and the specific authority to adopt and enforce such provisions of this code, unless otherwise stated.*

Application—Dairies and places of meat and poultry inspection.

Enforcing agency—Department of Food and Agriculture.

Authority cited—Food and Agricultural Code Sections 18735, 18960, 19384, 33481 and 33731.

Reference—Food and Agricultural Code Sections 18735, 18960, 19384, 33481 and 33731.

**SECTION 107
CALIFORNIA DEPARTMENT OF PUBLIC HEALTH**

107.1 *Specific scope of application of the agency responsible for enforcement, the enforcement agency and the specific authority to adopt and enforce such provisions of this code, unless otherwise stated.*

California Department of Public Health.

Application—Organized camps, laboratory animal quarters, public swimming pools, radiation protection and producing facilities, commissaries serving mobile food preparation vehicles, wild animal quarantine facilities, shellfish facilities and food establishments.

Enforcing agency—The California Department of Public Health and the local health agencies.

Authority cited—Health and Safety Code Sections 1660, 18897.2, 100275, 110065, 112165, 113710, 114304, 115061, 116050 and 121795.

Reference—Health and Safety Code Sections 1650, 1660, 18897.2, 18897.4, 18897.7, 100150, 100275, 110065, 113705, 113710, 114825, 114965, 115061, 116050, 116503, 112165 and 121795.

**SECTION 108
DEPARTMENT OF HOUSING AND COMMUNITY
DEVELOPMENT**

108.1 Purpose. *The purpose of this code is to establish the minimum requirements necessary to protect the health, safety and general welfare of the occupants and the public by governing accessibility, erection, construction, enlargement, conversion, alteration, repair, moving, removal, demolition, occupancy, use, height, court, area, sanitation, ventilation, maintenance, safety to life and property from fire and other hazards attributed to the built environment.*

108.2 Authority and abbreviations.

108.2.1 General. *The Department of Housing and Community Development is authorized by law to promulgate and adopt building standards and regulations for several types of building applications. These applications are grouped*

and identified by abbreviation in the Matrix Adoption Tables to show which model code sections and amendments are applicable to each application. The applications under the authority of the Department of Housing and Community Development are listed in Sections 108.2.1.1 through 108.2.1.3.

108.2.1.1 Housing construction. *Application—Hotels, motels, lodging houses, apartment houses, dwellings, dormitories, condominiums, shelters for homeless persons, congregate residences, employee housing, factory-built housing and other types of dwellings containing sleeping accommodations with or without common toilet or cooking facilities including accessory buildings, facilities, and uses thereto. Sections of this code which pertain to applications listed in this section are identified in the Matrix Adoption Table using the abbreviation “HCD 1.”*

Enforcing agency—Local building department or the Department of Housing and Community Development.

Authority cited—Health and Safety Code Sections 17921, 17922 and 19990.

Reference—Health and Safety Code Sections 17000 through 17060, 17910 through 17990 and 19960 through 19997.

108.2.1.2 Housing accessibility. *Application - Covered multifamily dwelling units as defined in Chapter 11A including, but not limited to, lodging houses, dormitories, timeshares, condominiums, shelters for homeless persons, congregate residences, apartment houses, dwellings, employee housing, factory-built housing and other types of dwellings containing sleeping accommodations with or without common toilet or cooking facilities.*

Sections of this code identified in the Matrix Adoption Table by the abbreviation “HCD 1-AC” require specific accommodations for persons with physical disabilities, as defined in Chapter 11A. The application of such provisions shall be in conjunction with other requirements of this code and apply only to Group R occupancies which are newly constructed covered multifamily dwellings as defined in Chapter 11A of the California Building Code. “HCD 1-AC” applications include, but are not limited to, the following:

1. All newly constructed covered multifamily dwellings as defined in Chapter 11A.
2. New common use areas as defined in Chapter 11A serving existing covered multifamily dwellings.
3. Additions to existing buildings, where the addition alone meets the definition of a “Covered multifamily dwelling” as defined in Chapter 11A.
4. Common use areas serving covered multifamily dwellings.

“HCD 1-AC” building standards generally do not apply to public use areas or public accommodations

such as hotels and motels. Public use areas, public accommodations and housing which is publicly funded as defined in Chapters 2, 11A and 11B of this code are subject to the Division of the State Architect (DSA-AC) and are referenced in Section 109.1.

Enforcing agency—Local building department or the Department of Housing and Community Development.

Authority cited—Health and Safety Code Sections 17921, 17922 and 19990 and Government Code Section 12955.1.

Reference—Health and Safety Code Sections 17000 through 17060, 17910 through 17990 and 19960 through 19997 and Government Code Section 12955.1.

108.2.1.3 Permanent buildings in mobilehome parks and special occupancy parks. Application-Permanent buildings, and permanent accessory buildings or structures, constructed within mobilehome parks and special occupancy parks that are under the control and ownership of the park operator. Sections of this code which pertain to applications listed in this section are identified in the Matrix Adoption Table using the abbreviation “HCD 2.”

Enforcing agency—Local building department or other local agency responsible for the enforcement of Health and Safety Code Division 13, Part 2.1 commencing with Section 18200 for mobilehome parks and Health and Safety Code Division 13, Part 2.3 commencing with Section 18860 for special occupancy parks or the Department of Housing and Community Development.

Authority cited—Health and Safety Code Sections 18300 and 18865.

Reference—Health and Safety Code Sections 18200 through 18700 and 18860 through 18874.

SECTION 108.3 LOCAL ENFORCING AGENCY

108.3.1 Duties and powers. The building department of every city, county or city and county shall enforce all the provisions of law, this code, and the other rules and regulations promulgated by the Department of Housing and Community Development pertaining to the installation, erection, reconstruction, movement, enlargement, conversion, alteration, repair, removal, demolition or arrangement of apartment houses, hotels and dwellings, including accessory buildings, facilities and uses thereto.

The provisions regulating the erection and construction of dwellings and appurtenant structures shall not apply to existing structures as to which construction is commenced or approved prior to the effective date of these regulations. Requirements relating to use, maintenance and occupancy shall apply to all dwellings and appurtenant structures approved for construction or constructed before or after the effective date of this code.

108.3.2 Laws, rules and regulations. Other than the building standards contained in this code, and notwithstanding other provisions of law, the statutory authority and location of the laws, rules and regulations to be enforced by local enforcing agencies are listed by statute in Sections 108.3.2.1 through 108.3.2.5 below:

108.3.2.1 State Housing Law. Refer to the State Housing Law, California Health and Safety Code, Division 13, Part 1.5 commencing with Section 17910 and California Code of Regulations, Title 25, Division 1, Chapter 1, Subchapter 1, Article 1, commencing with Section 1, for the erection, reconstruction, movement, enlargement, conversion, alteration, repair, removal, demolition or arrangement of apartment houses, hotels and dwellings, including accessory buildings, facilities and uses thereto.

108.3.2.2 Mobilehome Parks Act. Refer to the Mobilehome Parks Act, California Health and Safety Code, Division 13, Part 2.1, Article 1, commencing with Section 18200 and California Code of Regulations, Title 25, Division 1, Chapter 2, commencing with Section 1000 for mobilehome park administrative and enforcement authority, permits, plans, fees, violations, inspections and penalties both within and outside mobilehome parks.

Exception: Mobilehome parks where the Department of Housing and Community Development is the enforcing agency.

108.3.2.3 Special Occupancy Parks Act. Refer to the Special Occupancy Parks Act, California Health and Safety Code, Division 13, Part 2.3, commencing with Section 18860 and California Code of Regulations, Title 25, Division 1, Chapter 2.2, Article 1, commencing with Section 2000 for special occupancy park administrative and enforcement authority, permits, fees, violations, inspections and penalties both within and outside of special occupancy parks.

Exception: Special occupancy parks where the Department of Housing and Community Development is the enforcing agency.

108.3.2.4 Employee Housing Act. Refer to the Employee Housing Act, California Health and Safety Code, Division 13, Part 1, commencing with Section 17000 and California Code of Regulations, Title 25, Division 1, Chapter 1, Subchapter 3, Article 1, commencing with Section 600 for employee housing administrative and enforcement authority, permits, fees, violations, inspections and penalties.

108.3.2.5 Factory-Built Housing Law. Refer to the Factory-Built Housing Law, California Health and Safety Code, Division 13, Part 6 commencing with Section 19960 and California Code of Regulations, Title 25, Division 1, Chapter 3, Subchapter 1, Article 1, commencing with Section 3000 for factory-built housing administrative and enforcement authority, permits, fees, violations, inspections and penalties.

109.1.4.3 *The building department of every city, county or city and county within the territorial area of its city, county or city and county, where private funds are utilized. “Building department” means the department, bureau or officer charged with the enforcement of laws or ordinances regulating the erection or construction, or both the erection and construction, of buildings.*

109.1.5 Special conditions for persons with disabilities requiring appeals action ratification. *Whenever reference is made in these regulations to this section, the findings and determinations required to be rendered by the local enforcing agency shall be subject to ratification through an appeals process.*

109.1.6 Authority cited—Government Code Section 4450.

109.1.7 Reference cited—Government Code Sections 4450 through 4461 and 12955.1(d) and Health and Safety Code Sections 18949.1, 19952 through 19959.

109.2 Division of the State Architect—Structural Safety.

109.2.1 Application—*The Division of the State Architect—Structural Safety (DSA-SS) is authorized by law to promulgate building standards and administrative regulations for application to public elementary and secondary schools, community colleges and state-owned or state-leased essential services buildings.*

Enforcing agency—*The Division of the State Architect—Structural Safety (DSA-SS) has been delegated the responsibility and authority by the Department of General Services to review and approve the design and observe the construction of public elementary and secondary schools, community colleges and state-owned or state-leased essential services buildings.*

Authority cited—Education Code Sections 17310 and 81142 and Health and Safety Code Section 16022.

Reference—Education Code Sections 17280 through 17317, and 81130 through 81147 and Health and Safety Code Sections 16000 through 16023.

109.2.2 Applicable administrative standards.

1. Title 24, Part 1, California Code of Regulations:

- 1.1 Sections 4-301 through 4-355, Group 1, Chapter 4, for public elementary and secondary schools and community colleges.
- 1.2 Sections 4-201 through 4-249, Chapter 4, for state-owned or state-leased essential services buildings.

2. Title 24, Part 2, California Code of Regulations [applies to public elementary and secondary schools, community colleges and state-owned or state-leased essential services building(s)]:

- 2.1 Sections 101 and 109.2 of Chapter 1.
- 2.2 Sections 102.1, 102.2, 102.3, 102.4, 102.5, 104.9, 104.10 and 104.11 of Appendix Chapter 1.

109.2.3 Applicable building standards. *California Building Standards Code, Title 24, Parts 2, 3, 4, 5, 6, 9 and 12, California Code of Regulations, for school buildings, com-*

munity colleges and state-owned or state-leased essential service buildings.

The provisions of Title 24, Part 2, as adopted and amended by the Division of the State Architect—Structural Safety, shall apply to the applications listed in Section 109.2.1.

The Division of the State Architect—Structural Safety adopts the following building standards in Title 24, Part 2:

Chapters 2 through 10, 12, 14, 15, 16A, 17A, 18A, 19A, 20, 21A, 22A, 23, 24, 25, 26, 30, 31, 32, 33, 34, 35 and Appendix J.

109.2.4 Amendments. *Division of the State Architect—Structural Safety amendments in this code appear preceded with the acronym [DSA-SS].*

Exceptions:

1. Chapters 16A, 17A, 18A, 19A, 21A, and 22A—Amendments appearing in these chapters without an acronym have been co-adopted by DSA-SS and OSHPD.
2. Chapter 34, Sections 3115-3421—DSA-SS adopts these sections without the use of the DSA-SS acronym.

109.2.5 Reference to other chapters. *Where reference is made within this code to sections in Chapters 16, 17, 18, 19, 21 and 22, the respective sections in Chapters 16A, 17A, 18A, 19A, 21A and 22A shall apply instead.*

SECTION 110 OFFICE OF STATEWIDE HEALTH PLANNING AND DEVELOPMENT

110.1 OSHPD 1. *Specific scope of application of the agency responsible for enforcement, enforcement agency and the specific authority to adopt and enforce such provisions of this code, unless otherwise stated.*

Application—*General acute care hospitals and acute psychiatric hospitals, excluding distinct part units or distinct part freestanding buildings providing skilled nursing or intermediate care services. For structural regulations: Skilled nursing facilities and/or intermediate care facilities except those skilled nursing facilities and intermediate care facilities of single-story, Type V, wood or light steel-frame construction.*

Enforcing agency—*Office of Statewide Health Planning and Development (OSHPD). The office shall enforce the Division of the State Architect—Access Compliance regulations and the regulations of the Office of the State Fire Marshal for the above stated facility types.*

110.1.1 Applicable administrative standards.

1. Title 24, Part 1, California Code of Regulations: Chapters 6 and 7.
2. Title 24, Part 2, California Code of Regulations: Sections 101 and 110 of Chapter 1 and Appendix Chapter 1.

110.1.2 Applicable building standards. *California Building Standards Code, Title 24, Parts 2, 3, 4, 5, 9 and 12.* <

The provisions of Title 24, Part 2, as adopted and amended by OSHPD, shall apply to the applications listed in Section 110.1.

OSHPD 1 adopts the following building standards in Title 24, Part 2:

Chapters 2 through 10, 12, 14, 15, 16A, 17A, 18A, 19A, 20, 21A, 22A, 23, 24, 25, 26, 30, 31, 32, 33, 34A, 35 and Appendix J.

110.1.3 Identification of amendments. For applications listed in Section 110.1, amendments appear in this code preceded with the acronym [OSHPD 1], unless the entire chapter is applicable. When the entire chapter is adopted without amendments, all references to International Codes shall be replaced by equivalent California Codes.

110.1.4 Reference to other chapters. Where reference is made within this code to sections in Chapters 16, 17, 18, 19, 21, 22 and 34, the respective sections in Chapters 16A, 17A, 18A, 19A, 21A, 22A and 34A shall apply instead.

Authority—Health and Safety Code Sections 127010, 127015, 1275 and 129850.

References—Health and Safety Code Sections 19958, 127010, 127015, 129680, 1275 and 129675 through 130070.

110.2 OSHPD 2. Specific scope of application of the agency responsible for enforcement, enforcement agency and the specific authority to adopt and enforce such provisions of this code, unless otherwise stated.

Application—Skilled nursing facilities and intermediate care facilities, including distinct part skilled nursing and intermediate care services on a general acute care or acute psychiatric hospital license, provided either are in a separate unit or a free-standing building. For structural regulations: Single-story, Type V skilled nursing facility and/or intermediate care facilities utilizing wood or light steel-frame construction.

Enforcing agency—Office of Statewide Health Planning and Development (OSHPD). The office shall also enforce the Division of the State Architect—Access Compliance regulations and the regulations of the Office of the State Fire Marshal for the above-stated facility type.

110.2.1 Applicable administrative standards.

1. Title 24, Part 1, California Code of Regulations: Chapter 7.
2. Title 24, Part 2, California Code of Regulations: Sections 101 and 110 of Chapter 1 and Appendix Chapter 1.

110.2.2 Applicable building standards. California Building Standards Code, Title 24, Parts 2, 3, 4, 5, 9 and 12.

The provisions of Title 24, Part 2, as adopted and amended by OSHPD, shall apply to the applications listed in Section 110.2.

OSHPD 2 adopts the following building standards in Title 24, Part 2:

Chapters 2 through 10, 12, 14, 15, 16, 17, 18, 19, 20, 21, 22, 23, 24, 25, 26, 30, 31, 32, 33, 34, 35 and Appendix J.

110.2.3 Identification of amendments. For applications listed in Section 110.2, amendments appear in this code preceded with the acronym [OSHPD 2]. When the entire chapter is adopted without amendments, all references to International Codes shall be replaced by equivalent California Codes.

Authority—Health and Safety Code Sections 127010, 127015, 1275 and 129850.

References—Health and Safety Code Sections 127010, 127015, 1275 and 129680.

110.3 OSHPD 3. Specific scope of application of the agency responsible for enforcement, enforcement agency and the specific authority to adopt and enforce such provisions of this code, unless otherwise stated.

Application—Licensed clinics and any freestanding building under a hospital license where outpatient clinical services are provided.

Enforcing agency—Local building department.

110.3.1 Applicable administrative standards.

1. Title 24, Part 1, California Code of Regulations: Chapter 7.
2. Title 24, Part 2, California Code of Regulations: Sections 101 and 110 of Chapter 1 and Appendix Chapter 1.

110.3.2 Applicable building standards. California Building Standards Code, Title 24, Parts 2, 3, 4, 5, 9 and 12.

The provisions of Title 24, Part 2, as adopted and amended by OSHPD, shall apply to the applications listed in Section 110.3.

OSHPD 3 adopts the following building standards in Title 24, Part 2:

Chapters 2 through 10, 12, 14, 15, 16, 17, 18, 19, 20, 21, 22, 23, 24, 25, 26, 30, 31, 32, 33, 34, 35 and Appendix J.

110.3.3 Identification of amendments. For applications listed in Section 110.3, amendments appear in this code without the acronym [OSHPD 3]. Adoptions are shown in the adoption matrix. When the entire chapter is adopted without amendments, all references to International Codes shall be replaced by equivalent California Codes.

Authority—Health and Safety Code Sections 127010, 127015 and 1226.

References—Health and Safety Code Sections 127010, 127015, 129885 and 1226, Government Code Section 54350 and State Constitution Article 11, Section 7.

110.4 OSHPD 4. Specific scope of application of the agency responsible for enforcement, enforcement agency and the specific authority to adopt and enforce such provisions of this code, unless otherwise stated.

Application—Correctional treatment centers.

Enforcing agency—Office of Statewide Health Planning and Development (OSHPD). The office shall also enforce the Division of the State Architect—Access Compliance regulations and the regulations of the Office of the State Fire Marshal for the above-stated facility types.

110.4.1 Applicable administrative standards.

1. Title 24, Part 1, California Code of Regulations: Chapter 7.
2. Title 24, Part 2, California Code of Regulations: Sections 101 and 110 of Chapter 1 and Appendix Chapter 1.

110.4.2 Applicable building standards. California Building Standards Code, Title 24, Parts 2, 3, 4, 5, 9 and 12.

The provisions of Title 24, Part 2, as adopted and amended by OSHPD, shall apply to the applications listed in Section 110.4.

OSHPD 4 adopts the following building standards in Title 24, Part 2:

Chapters 2 through 10, 12, 14, 15, 16A, 17A, 18A, 19A, 20, 21A, 22A, 23, 24, 25, 26, 30, 31, 32, 33, 34A, 35 and Appendix J.

110.4.3 Identification of amendments. For applications listed in Section 110.4, amendments appear in this code preceded with the acronym [OSHPD 4], unless the entire chapter is applicable. When the entire chapter is adopted without amendments, all references to International Codes shall be replaced by equivalent California Codes.

110.4.4 Reference to other chapters. Where reference is made within this code to sections in Chapters 16, 17, 18, 19, 21, 22 and 34, the respective sections in Chapters 16A, 17A, 18A, 19A, 21A, 22A and 34A shall apply instead.

Authority—Health and Safety Code Sections 127010, 127015 and 129790.

References—Health and Safety Code Sections 127010, 127015, 1275 and 129675 through 130070.

SECTION 111 OFFICE OF THE STATE FIRE MARSHAL

111.1 SFM—Office of the State Fire Marshal.

Any building or structure used or intended for use as an asylum, jail, mental hospital, hospital, sanitarium, home for the aged, children's nursery, children's home, school or any similar occupancy of any capacity.

Any theater, dancehall, skating rink, auditorium, assembly hall, meeting hall, nightclub, fair building or similar place of assemblage where 50 or more persons may gather together in a building, room or structure for the purpose of amusement, entertainment, instruction, deliberation, worship, drinking or dining, awaiting transportation, or education.

Authority cited—Health and Safety Code Section 13143.

Reference—Health and Safety Code Section 13143.

Small family day care homes.

Authority cited—Health and Safety Code Sections 1597.45, 1597.54, 13143 and 17921.

Reference - Health and Safety Code Section 13143.

Large family day care homes.

Authority cited—Health and Safety Code Sections 1597.46, 1597.54 and 17921.

Reference - Health and Safety Code Section 13143.

Residential facilities and residential facilities for the elderly.

Authority cited—Health and Safety Code Section 13133.

Reference—Health and Safety Code Section 13143.

Any state institution or other state-owned or state-occupied building.

Authority cited—Health and Safety Code Section 13108.

Reference—Health and Safety Code Section 13143.

High-rise structures.

Authority cited—Health and Safety Code Section 13211.

Reference—Health and Safety Code Section 13143.

Motion picture production studios.

Authority cited—Health and Safety Code Section 13143.1.

Reference—Health and Safety Code Section 13143.

Organized camps.

Authority cited—Health and Safety Code Section 18897.3.

Reference—Health and Safety Code Section 13143.

Residential.

All hotels, motels, lodging houses, apartment houses and dwellings, including congregate residences and buildings and structures accessory thereto.

Multiple-story structures existing on January 1, 1975, let for human habitation, including and limited to, hotels, motels and apartment houses, less than 75 feet (22 860 mm) above the lowest floor level having building access, wherein rooms used for sleeping are let above the ground floor.

Authority cited—Health and Safety Code Sections 13143.2 and 17921.

Reference—Health and Safety Code Section 13143.

Residential care facilities.

Certified family care homes, out-of-home placement facilities, halfway houses, drug and/or alcohol rehabilitation facilities and any building or structure used or intended for use as a home or institution for the housing of any person of any age when such person is referred to or placed within such home or institution for protective social care and supervision services by any governmental agency.

Authority cited—Health and Safety Code Section 13143.6.

Tents, awnings or other fabric enclosures used in connection with any occupancy.

Authority cited—Health and Safety Code Section 13116.

Reference—Health and Safety Code Section 13143.

Enforcing agency—Pursuant to Section 13146, Health and Safety Code.

Fire alarm devices, equipment and systems in connection with any occupancy.

Authority cited—Health and Safety Code Section 13114.

Hazardous materials.

Authority cited—Health and Safety Code Section 13143.9.

Flammable and combustible liquids.

Authority cited—Health and Safety Code Section 13143.6.

Public School Automatic Fire Detection, Alarm and Sprinkler Systems.

Authority cited—Health and Safety Code Section 13143 and California Education Code Article 7.5, Sections 17074.50, 17074.52 and 17074.54.

Reference—Government Code Section 11152.5, Health and Safety Code Section 13143 and California Education Code Chapter 12.5, Leroy F. Greene School Facilities Act of 1998, Article 1.

Wildland-Urban Interface Fire Area.

Authority cited—Health and Safety Code Sections 13143, 13108.5(a) and 18949.2(b) and (c) and Government Code Section 51189.

Reference—Health and Safety Code Sections 13143, Government Code Sections 51176, 51177, 51178 and 51179 and Public Resources Code Sections 4201 through 4204.

111.2 Duties and powers of the enforcing agency.**111.2.1 Enforcement.**

111.2.1.1 The responsibility for enforcement of building standards adopted by the State Fire Marshal and published in the California Building Standards Code relating to fire and panic safety and other regulations of the Office of the State Fire Marshal shall be as follows:

1. The city, county or city and county with jurisdiction in the area affected by the standard or regulation shall delegate the enforcement of the building standards relating to fire and panic safety and other regulations of the State Fire Marshal as they relate to Group R, Division 3 dwellings, as described in Section 310.1 of Part 2 of the California Building Standards Code, to either of the following:
 - 1.1. The chief of the fire authority of the city, county or city and county, or an authorized representative.
 - 1.2. The chief building official of the city, county or city and county, or an authorized representative.
2. The chief of any city or county fire department or of any fire protection district, and authorized representatives, shall enforce within the jurisdiction the building standards and other regulations of the State Fire Marshal, except those described in Item 1 or 4.
3. The State Fire Marshal shall have authority to enforce the building standards and other regulations of the State Fire Marshal in areas outside of corporate cities and districts providing fire protection services.

4. The State Fire Marshal shall have authority to enforce the building standards and other regulations of the State Fire Marshal in corporate cities and districts providing fire protection services on request of the chief fire official or the governing body.

5. Any fee charged pursuant to the enforcement authority of this section shall not exceed the estimated reasonable cost of providing the service for which the fee is charged pursuant to Section 66014 of the Government Code.

111.2.1.2 Pursuant to Health and Safety Code Section 13108, upon the written request of the chief fire official of any city, county or fire protection district, the State Fire Marshal may authorize such chief fire official and his or her authorized representatives, in their geographical area of responsibility, to make fire prevention inspections of state-owned or state-occupied buildings, other than state institutions, for the purpose of enforcing the regulations relating to fire and panic safety adopted by the State Fire Marshal pursuant to this section and building standards relating to fire and panic safety published in the California Building Standards Code. Authorization from the State Fire Marshal shall be limited to those fire departments or fire districts which maintain a fire prevention bureau staffed by paid personnel.

Pursuant to Health and Safety Code Section 13108, any requirement or order made by any chief fire official who is authorized by the State Fire Marshal to make fire prevention inspections of state-owned or state-occupied buildings, other than state institutions, may be appealed to the State Fire Marshal. The State Fire Marshal shall, upon receiving an appeal and subject to the provisions of Chapter 5 (commencing with Section 18945) of Part 2.5 of Division 13 of the Health and Safety Code, determine if the requirement or order made is reasonably consistent with the fire and panic safety regulations adopted by the Office of the State Fire Marshal and building standards relating to fire and panic safety published in the California Building Code.

Any person may request a code interpretation from the State Fire Marshal relative to the intent of any regulation or provision adopted by the State Fire Marshal. When the request relates to a specific project, occupancy or building, the State Fire Marshal shall review the issue with the appropriate local enforcing agency prior to rendering such code interpretation.

111.2.1.3 Pursuant to Health and Safety Code Section 13112, any person who violates any order, rule or regulation of the State Fire Marshal is guilty of a misdemeanor punishable by a fine of not less than \$100.00 or more than \$500.00, or by imprisonment for not less than six months, or by both. A person is guilty of a separate offense each day during which he or she commits, continues or permits a violation of any provision of, or any order, rule or regulation of, the State Fire Marshal as contained in this code.

**CALIFORNIA BUILDING CODE – MATRIX ADOPTION TABLE
CHAPTER 2 – DEFINITIONS**

Adopting Agency	BSC	SFM	HCD			DSA		OSHDPD				CSA	DHS	AGR	DWR	CEC	CA	SL	SLC
			1	2	1/AC	AC	SS	1	2	3	4								
Adopt Entire Chapter	X						X												
Adopt Entire Chapter as amended (amended sections listed below)		X	X	X	X				X	X	X	X							
Adopt only those sections that are listed below							X												
Chapter / Section	Codes																		
201.3	CA		x						x	x	x	x							
201.4	CA		x																
Access Aisle	CA						x												
Accessibility	CA			x	x	x	x												
Accessible	CA						x												
Accessible	IBC			x	x	x													
Accessible Element	CA						x												
Accessible Means of Egress	IBC						x												
Accessible Route	CA						x												
Accessible Route	IBC			x	x	x													
Accessible Route of Travel	CA						x												
Accessible Space	CA						x												
Accessible Unit	IBC			†	†	†													
Adaptability	CA						x												
Adaptable Dwelling Unit	CA			x	x	x	x												
Addition	CA						x												
Administrative Authority	CA						x												
Aged Home or Institution	CA		x																
Aisle	CA						x												
Aisle, Employee Areas	CA						x												
Alteration (or Alter)	CA						x												
Alternate Card Reader	CA						x												
ANSI	CA						x												
Approved w/o notes	CA						x												
Approved	IBC			x	x	x													
Approved Listing Agency	CA			x	x	x													
Approved Testing Agency	CA			x	x	x	x												
Area of Refuge	IBC						x												
Assembly Area	CA						x												
Assistive Device	CA			x	x	x	x												
Automatic Door	CA			x	x	x	x												
Bathroom	CA			x		x	x												

CHAPTER 2 – DEFINITIONS (Continued)

Adopting Agency	BSC	SFM	HCD			DSA		OSHPD				CSA	DHS	AGR	DWR	CEC	CA	SL	SLC
			1	2	1/AC	AC	SS	1	2	3	4								
Adopt Entire Chapter	X						X												
Adopt Entire Chapter as amended (amended sections listed below)		X	X	X	X				X	X	X	X							
Adopt only those sections that are listed below							X												
Chapter / Section	Codes																		
Bedridden Person	CA	x																	
Building	IBC		x	x	x	x													
Building	CA	x																	
Building Entrance on an Accessible Route	CA		x	x	x	x													
Building, Existing	CA		x	x	x	x													
Building Official	IBC		x	x	x	x													
Care and Supervision	CA	x																	
Catastrophically Injured	CA	x																	
CCR	CA						x												
Cell	CA	x																	
Cellular Concrete	CA		x	x	x														
Child-Care Center	CA	x																	
Child or Children	CA	x																	
Chronically Ill	CA	x																	
Circulation Path	CA						x												
Circulation Path	IBC		x	x	x														
Clear	CA						x												
Clear Floor Space	CA						x												
Closed-Circuit Telephone	CA						x												
Commercial Facilities	CA						x												
Common Use Areas	CA		x	x	x	x													
Comply with	CA						x												
Concrete, Cellular	IBC		x	x	x														
Congregate Living Health Facility (CLHF)	CA	x																	
Congregate Residence	CA	x																	
Covered Multifamily Dwellings	CA		x	x	x	x	x												
Cross Slope	CA		x	x	x	x	x												
Curb Cut	CA		x	x	x	x	x												
Curb Ramp	CA		x	x	x	x	x												
DayCare	CA	x																	
Day-Care Home, Large Family	CA	x																	
Day-Care Home, Small Family	CA	x																	
Department	CA		x	x	x														
Detached Single-Family Dwelling	CA		x	x	x														

||

CHAPTER 2 – DEFINITIONS (Continued)

Adopting Agency	BSC	SFM	HCD			DSA		OSHPD				CSA	DHS	AGR	DWR	CEC	CA	SL	SLC
			1	2	1/AC	AC	SS	1	2	3	4								
Adopt Entire Chapter	X						X												
Adopt Entire Chapter as amended (amended sections listed below)		X	X	X	X				X	X	X	X							
Adopt only those sections that are listed below							X												
Chapter / Section	Codes																		
Detectable Warning	CA			x	x	x	x												
Detectable Warning	IBC			x	x	x													
Directional Sign	CA			x	x	x	x												
Disability	CA						x												
Disabled	CA						x												
Dormitory	IBC						x												
Dormitory	CA		x																
Dwelling Unit	CA					X	x												
Dwelling Unit or Sleeping Unit, Multistory	IBC			†	†	†													
Dwelling Unit or Sleeping Unit, Type A	IBC			†	†	†													
Dwelling Unit or Sleeping Unit, Type B	IBC			†	†	†													
Efficiency Dwelling Unit	CA			x	x	x													
Electric Vehicle	CA		x																
Element	CA						x												
Elevator, Passenger	CA						x												
Enforcement	CA			x	x	x													
Enforcing Agency	CA		x	x	x	x	x												
Entrance	CA						x												
Equivalent Facilitation	CA			x	x	x	x												
Existing Building	IBC						x												
Exit	IBC						x												
Facility (or Facilities)	CA			x	x	x	x												
Facility	IBC			†	†	†													
Family	CA			x		x													
Free-standing Pedestal	CA						x												
Full-Time Care	CA		x																
Grab Bar	CA			x	x	x	x												
Grade (Adjacent Ground Elevation)	CA						x												
Grade	CA			X	X														
Grade Plane	IBC			x	x	x													
Ground Floor	CA						x												
Guard (or Guardrail)	CA			x	x														
Guard (or Guardrail)	IBC			x	x	x	x												



CHAPTER 2 – DEFINITIONS (Continued)

Adopting Agency	BSC	SFM	HCD			DSA		OSHPD				CSA	DHS	AGR	DWR	CEC	CA	SL	SLC
			1	2	1/AC	AC	SS	1	2	3	4								
Adopt Entire Chapter	X						X												
Adopt Entire Chapter as amended (amended sections listed below)		X	X	X	X			X	X	X	X								
Adopt only those sections that are listed below							X												
Chapter / Section	Codes																		
Handrail	IBC		x	x	x	x													
Hazardous Substance	CA	x																	
Health Care Provider	CA						x												
High-Rise Building	CA	x																	
Historical Building	CA						x												
If, If . . . Then	CA						x												
Impact Insulation Class (IIC)	CA		x	x	x														
Independent Entity	CA						x												
Infant	CA	x																	
Intended to be Occupied as a Residence	IBC		†	†	†														
International Symbol of Accessibility	CA		x	x	x	x													
Kick Plate	CA		x	x	x	x													
Laboratory	CA	x																	
Level Accessible Area	CA						x												
Level Area	CA		x	x	x	x													
Lift, Platform (Wheelchair)	CA					x	x												
Listed	CA	x	x	x	x														
Listed	IBC		x	x	x														
Listing Agency	CA		x	x	x														
Lobby	CA	x	x	x	x														
Lodging House	CA		x	x	x														
Marked Crossing	CA		x	x	x	x													
May	CA						x												
Mentally Retarded Persons, Profoundly or Severely	CA	x																	
Modernization Project	CA	x																	
Motion Picture and Television Production Studio Sound Stages, Approved Production Facilities and Production Locations	CA	x																	
Multilevel Assembly Seating	IBC		†	†	†														

CHAPTER 2 – DEFINITIONS (Continued)

Adopting Agency	BSC	SFM	HCD			DSA		OSHDPD				CSA	DHS	AGR	DWR	CEC	CA	SL	SLC
			1	2	1/AC	AC	SS	1	2	3	4								
Adopt Entire Chapter	X						X												
Adopt Entire Chapter as amended (amended sections listed below)		X	X	X	X			X	X	X	X								
Adopt only those sections that are listed below							X												
Chapter / Section	Codes																		
Multistory Dwelling Unit	CA		X	X	X	X													
Multiple-Accommodation Toilet Facility	CA						X												
New Public School Campus	CA	X																	
Newly Constructed	CA		X	X	X	X													
Nonambulatory Persons	CA	X																	
Noncombustible	CA	X																	
Normal	CA		X	X	X														
Nosing (or Nose)	CA		X	X	X	X													
NFPA	CA						X												
Occupiable Space	IBC						X												
Open Riser	CA		X	X	X	X													
Operable Part	CA						X												
Organized Camps	CA	X																	
Passage Door	CA		X	X	X	X													
Passenger Elevator	CA		X	X	X	X													
Passive Solar Energy Collector	CA		X	X	X														
Path of Travel	CA						X												
Pedestrian	CA		X	X	X	X													
Pedestrian Grade Separation	CA						X												
Pedestrian Way	CA		X	X	X	X													
Permanent	CA						X												
Permanent Portable Building	CA	X																	
Permit	IBC						X												
Persons with Disabilities	CA		X	X	X	X													
Platform	IBC						X												
Platform (Wheelchair) Lift	CA					X	X												
Photoluminescent	CA	X																	
Portable Building	CA	X																	
Powder Room	CA		X	X	X	X													
Power-assisted Door	CA						X												
Primary Entry	CA		X	X	X														
Primary-Entry Level			X	X	X														

CHAPTER 2 – DEFINITIONS (Continued)

Adopting Agency	BSC	SFM	HCD			DSA		OSHPD				CSA	DHS	AGR	DWR	CEC	CA	SL	SLC
			1	2	1/AC	AC	SS	1	2	3	4								
Adopt Entire Chapter	X						X												
Adopt Entire Chapter as amended (amended sections listed below)		X	X	X	X			X	X	X	X								
Adopt only those sections that are listed below																			
Chapter / Section	Codes																		
Professional Office of a Health Care Provider	CA						X												
Protective Social Care	CA		X																
Public Accommodation	CA			X	X	X	X												
Public Entrance	IBC			X	X	X													
Publicly Funded	CA			X	X	X	X												
Public-Use Areas	CA			X	X	X	X												
Public-Use Areas	IBC			X	X	X													
Public Way	IBC						X												
Qualified Historical Building (or Property)	CA						X												
Rail Transit Boarding Platform	CA						X												
Ramp	CA			X	X	X	X												
Reasonable Portion	CA						X												
Recommend	CA			X	X	X	X												
Remodeling	CA						X												
Repair	IBC						X												
Residential Care Facility for the Chronically Ill (RCF/CI)	CA		X																
Residential Care Facility for the Elderly (RCFE)	CA		X																
Residential Facility (RF)	CA		X																
Restraint	CA		X																
Restricted Entrance	IBC			X	X	X													
Riser	CA			X	X	X	X												
Running Slope	CA						X												
Sanitary Facility	CA			X	X	X	X												
Self-Luminous	CA		X																
Self Service Storage Facility	IBC			†	†	†													
Service Entrance	IBC			X	X	X													
Service Entrance	CA						X												
Shall	CA						X												
Shopping Center or Shopping Mall	CA			X	X	X	X												
Should	CA			X	X	X	X												
Sidewalk	CA			X	X	X	X												

CHAPTER 2 – DEFINITIONS (Continued)

Adopting Agency	BSC	SFM	HCD			DSA		OSHDP				CSA	DHS	AGR	DWR	CEC	CA	SL	SLC
			1	2	1/AC	AC	SS	1	2	3	4								
Adopt Entire Chapter	X						X												
Adopt Entire Chapter as amended (amended sections listed below)		X	X	X	X			X	X	X	X								
Adopt only those sections that are listed below							X												
Chapter / Section	Codes																		
Signage	CA						X												
Single-Accommodation Sanitary Facility	CA			X	X	X	X												
Site	CA			X	X	X	X												
Site	IBC			X	X	X													
Site Development	CA			X	X	X	X												
Sleeping Accommodations	CA			X	X	X	X												
Slope	CA			X	X	X	X												
Sound Transmission Class (STC)	CA			X	X	X													
Space	CA			X	X	X	X												
Specified Public Transportation	CA						X												
Stage	IBC						X												
Stair	IBC						X												
Stairway	IBC						X												
State-Owned/Leased Building	CA		X																
Story	CA						X												
Story, First	CA						X												
Structural Frame	CA						X												
Structure	IBC						X												
Tactile	CA			X	X	X	X												
Technically Infeasible	CA						X												
Temporary	CA						X												
Terminally Ill	CA		X																
Testing Agency	CA			X	X	X													
Text Telephone	CA						X												
Townhouse	IBC			X	X	X													

<

<

CHAPTER 2 – DEFINITIONS (Continued)

Adopting Agency	BSC	SFM	HCD			DSA		OSHPD				CSA	DHS	AGR	DWR	CEC	CA	SL	SLC
			1	2	1/AC	AC	SS	1	2	3	4								
Adopt Entire Chapter	X						X												
Adopt Entire Chapter as amended (amended sections listed below)		X	X	X	X			X	X	X	X								
Adopt only those sections that are listed below						X													
Chapter / Section	Codes																		
Transient Lodging	CA		x	x	x	x													
Transit Boarding Platform	CA					x													
Tread	CA		x	x	x	x													
Tread Depth	CA		x	x	x														
Tread Run	CA		x	x	x														
Type of Motor Fuel	CA					x													
Unreasonable Hardship	CA					x													
Vehicular or Pedestrian Arrival Points	CA		x	x	x	x													
Vehicular Way	CA					x													
Waiting Room	CA	x																	
Walk	CA		x	x	x	x													
Wheelchair	CA		x	x	x	x													
Wheelchair Occupant (or Wheelchair User)	CA					x													
Wheelchair Space	IBC		x	x	x														
Winery Caves	CA	x																	
Work Station	CA					x													

>
>

The state agency does not adopt sections identified with the following symbol: †

[F] AVERAGE AMBIENT SOUND LEVEL. See Section 902.1.

AWNING. An architectural projection that provides weather protection, identity or decoration and is wholly supported by the building to which it is attached. An awning is comprised of a lightweight, rigid skeleton structure over which a covering is attached.

BACKING. See Section 1402.1.

BALCONY, EXTERIOR. See Section 1602.1.

BALED COTTON. See Section 307.2.

BALED COTTON, DENSELY PACKED. See Section 307.2.

[F] BARRICADE. See Section 307.2.

Artificial barricade. See Section 307.2.

Natural barricade. See Section 307.2.

BASE FLOOD. See Section 1612.2.

BASE FLOOD ELEVATION. See Section 1612.2.

BASEMENT. See Sections 502.1 and 1612.2.

BATHROOM. [DSA-AC & HCD 1-AC] See Chapter 11A, Section 1107A.2-B.

BED JOINT. See Section 2102.1.

BEDRIDDEN PERSON. See Section 310.

BLEACHERS. See Section 1002.1.

BOARDING HOUSE. See Section 310.2.

[F] BOILING POINT. See Section 307.2.

BOND BEAM. See Section 2102.1.

BOND REINFORCING. See Section 2102.1.

BRACED WALL LINE. See Section 2302.1.

BRACED WALL PANEL. See Section 2302.1.

BRICK. See Section 2102.1.

Calcium silicate (sand lime brick). See Section 2102.1.

Clay or shale. See Section 2102.1.

Concrete. See Section 2102.1.

BUILDING. Any structure used or intended for supporting or sheltering any use or occupancy.

Exception: [HCD 1, HCD 2 & HCD 1-AC] For applications listed in Section 108.2 regulated by the Department of Housing and Community Development, "Building" shall not include the following:

1. Any mobilehome as defined in Health and Safety Code Section 18008.
2. Any manufactured home as defined in Health and Safety Code Section 18007.
3. Any commercial modular as defined in Health and Safety Code Section 18001.8 or any special purpose commercial modular as defined in Section 18012.5.
4. Any recreational vehicle as defined in Health and Safety Code Section 18010.

5. Any multi-unit manufactured housing as defined in Health and Safety Code Section 18008.7.

For additional information, see Health and Safety Code Section 18908.

Note: [SFM] "Building" shall have the same meaning as defined in Health and Safety Code Sections 17920 and 18908 for the applications specified in Section 111.

BUILDING ENTRANCE ON AN ACCESSIBLE ROUTE. [DSA-AC & HCD 1-AC] See Chapter 11A, Section 1107A.2-B.

BUILDING, EXISTING [DSA-AC & HCD 1 & HCD 2] is a building erected prior to the adoption of this code, or one for which a legal building permit has been issued.

BUILDING LINE. The line established by law, beyond which a building shall not extend, except as specifically provided by law.

BUILDING OFFICIAL. The officer or other designated authority charged with the administration and enforcement of this code, or a duly authorized representative.

BUILT-UP ROOF COVERING. See Section 1502.1.

BUTTRESS. See Section 2102.1.

CABLE-RESTRAINED, AIR-SUPPORTED STRUCTURE. See Section 3102.2.

CANOPY. An architectural projection that provides weather protection, identity or decoration and is supported by the building to which it is attached and at the outer end by not less than one stanchion. A canopy is comprised of a rigid structure over which a covering is attached.

[F] CARBON DIOXIDE EXTINGUISHING SYSTEMS. See Section 902.1.

CARE AND SUPERVISION. See Section 310.

CAST STONE. See Section 2102.1.

CATASTROPHICALLY INJURED. See Section 310.

CCR [DSA-AC] means the California Code of Regulations.

[F] CEILING LIMIT. See Section 902.1.

CEILING RADIATION DAMPER. See Section 702.1.

CELL. See Sections 308.4.6 and 2102.1.

CELLULAR CONCRETE [HCD 1 & HCD 2] is a lightweight product consisting of portland cement and selected gas-forming chemicals or foaming agents which create homogeneous voids in the hardened concrete.

CEMENT PLASTER. See Section 2502.1.

CERAMIC FIBER BLANKET. See Section 721.1.1.

CERTIFICATE OF COMPLIANCE. See Section 1702.1.

CHILD or CHILDREN. See Section 310.

CHILD CARE CENTER. See Section 310.

CHIMNEY. See Section 2102.1.

CHIMNEY TYPES. See Section 2102.1.

High-heat appliance type. See Section 2102.1.

Low-heat appliance type. See Section 2102.1.

DEFINITIONS

- Masonry type.** See Section 2102.1.
- Medium-heat appliance type.** See Section 2102.1.
- CHRONICALLY ILL.** [SFM] See Section 310.
- CIRCULATION PATH.** [DSA-AC & HCD 1-AC] See Chapter 11B, Section 1102B.
- [F] CLEAN AGENT.** See Section 902.1.
- CLEANOUT.** See Section 2102.1.
- CLEAR.** [DSA-AC] See Chapter 11B, Section 1102B.
- CLEAR FLOOR SPACE.** [DSA-AC] See Chapter 11B, Section 1102B.
- CLOSED-CIRCUIT TELEPHONE.** [DSA-AC] See Chapter 11B, Section 1102B.
- [F] CLOSED SYSTEM.** See Section 307.2.
- COLLAR JOINT.** See Section 2102.1.
- COLLECTOR.** See Section 2302.1.
- COLUMN, MASONRY.** See Section 2102.1.
- COMBINATION FIRE/SMOKE DAMPER.** See Section 702.1.
- [F] COMBUSTIBLE DUST.** See Section 307.2.
- [F] COMBUSTIBLE FIBERS.** See Section 307.2.
- [F] COMBUSTIBLE LIQUID.** See Section 307.2.
- Class II.** See Section 307.2.
- Class IIIA.** See Section 307.2.
- Class IIIB.** See Section 307.2.
- COMMERCIAL FACILITIES** [DSA-AC] are facilities that are intended for nonresidential use and whose operations will affect commerce, including factories, warehouses, office buildings and other buildings in which employment may occur. Commercial facilities shall not include railroad locomotives, railroad freight cars, railroad cabooses, railroad cars covered under Title II of the Americans with Disabilities Act of 1990 or facilities that are covered or expressly exempted from coverage under the Fair Housing Amendment Act of 1988 (42 USC 3601-3631, et seq).
- COMMON PATH OF EGRESS TRAVEL.** See Section 1002.1.
- COMMON USE AREAS.** [DSA-AC & HCD 1-AC] See Chapter 11A, Section 1107A.3-C, and Chapter 11B, Section 1102B.
- COMPLY WITH.** [DSA-AC] See Chapter 11B, Section 1102B.
- COMPOSITE ACTION.** See Section 2102.1.
- COMPOSITE MASONRY.** See Section 2102.1.
- [F] COMPRESSED GAS.** See Section 307.2.
- COMPRESSIVE STRENGTH OF MASONRY.** See Section 2102.1.
- CONCRETE, CARBONATE AGGREGATE.** See Section 721.1.1.
- CONCRETE, CELLULAR.** [HCD 1 & HCD 2] See Section 721.1.1. See "Cellular concrete."
- CONCRETE, LIGHTWEIGHT AGGREGATE.** See Section 721.1.1.
- CONCRETE, PERLITE.** See Section 721.1.1.
- CONCRETE, SAND-LIGHTWEIGHT.** See Section 721.1.1.
- CONCRETE, SILICEOUS AGGREGATE.** See Section 721.1.1.
- CONCRETE, VERMICULITE.** See Section 721.1.1.
- CONGREGATE LIVING FACILITIES.** See Section 310.2.
- CONGREGATE LIVING HEALTH FACILITY (CLHF).** See Section 310.
- CONGREGATE RESIDENCE.** See Section 310.
- CONNECTOR.** See Section 2102.1.
- [F] CONSTANTLY ATTENDED LOCATION.** See Section 902.1.
- CONSTRUCTION DOCUMENTS.** Written, graphic and pictorial documents prepared or assembled for describing the design, location and physical characteristics of the elements of a project necessary for obtaining a building permit.
- CONSTRUCTION TYPES.** See Section 602.
- Type I.** See Section 602.2.
- Type II.** See Section 602.2.
- Type III.** See Section 602.3.
- Type IV.** See Section 602.4.
- Type V.** See Section 602.5.
- [F] CONTINUOUS GAS-DETECTION SYSTEM.** See Section 415.2.
- [F] CONTROL AREA.** See Section 307.2.
- CONTROLLED LOW-STRENGTH MATERIAL.** A self-compacted, cementitious material used primarily as a backfill in place of compacted fill.
- CONVENTIONAL LIGHT-FRAME WOOD CONSTRUCTION.** See Section 2302.1.
- CORRIDOR.** See Section 1002.1.
- CORROSION RESISTANCE.** The ability of a material to withstand deterioration of its surface or its properties when exposed to its environment.
- [F] CORROSIVE.** See Section 307.2.
- COURT.** An open, uncovered space, unobstructed to the sky, bounded on three or more sides by exterior building walls or other enclosing devices.
- COVER.** See Section 2102.1.
- COVERED MALL BUILDING.** See Section 402.2.
- COVERED MULTIFAMILY DWELLINGS.** [DSA-AC & HCD 1-AC] See Chapter 11A, Section 1107A.3-C.
- CRIPPLE WALL.** See Section 2302.1.
- CROSS SLOPE.** [DSA-AC & HCD 1-AC] See Chapter 11A, Section 1107A.3-C, and Chapter 11B, Section 1102B.
- CRYOGENIC FLUID.** See Section 307.2.

FIRE-RETARDANT TREATED WOOD [SFM] See Section 2303.2.

[F] **FIRE SAFETY FUNCTIONS.** See Section 902.1.

FIRE SEPARATION DISTANCE. See Section 702.1.

FIRE WALL. See Section 702.1.

FIRE WINDOW ASSEMBLY. See Section 702.1.

FIREBLOCKING. See Section 702.1.

FIREPLACE. See Section 2102.1.

FIREPLACE THROAT. See Section 2102.1.

FIREWORKS. See Section 307.2.

FIREWORKS, 1.3G. See Section 307.2.

FIREWORKS, 1.4G. See Section 307.2.

FLAME SPREAD. See Section 802.1.

FLAME SPREAD INDEX. See Section 802.1.

[F] **FLAMMABLE GAS.** See Section 307.2.

[F] **FLAMMABLE LIQUEFIED GAS.** See Section 307.2.

[F] **FLAMMABLE LIQUID.** See Section 307.2.

Class IA. See Section 307.2.

Class IB. See Section 307.2.

Class IC. See Section 307.2.

[F] **FLAMMABLE MATERIAL.** See Section 307.2.

[F] **FLAMMABLE SOLID.** See Section 307.2.

[F] **FLAMMABLE VAPORS OR FUMES.** See Section 415.2.

[F] **FLASH POINT.** See Section 307.2.

FLEXURAL LENGTH. See Section 1808.1.

FLOOD OR FLOODING. See Section 1612.2.

FLOOD DAMAGE-RESISTANT MATERIALS. See Section 1612.2.

FLOOD HAZARD AREA. See Section 1612.2.

FLOOD HAZARD AREA SUBJECT TO HIGH VELOCITY WAVE ACTION. See Section 1612.2.

FLOOD INSURANCE RATE MAP (FIRM). See Section 1612.2.

FLOOD INSURANCE STUDY. See Section 1612.2.

FLOODWAY. See Section 1612.2.

FLOOR AREA, GROSS. See Section 1002.1.

FLOOR AREA, NET. See Section 1002.1.

FLOOR FIRE DOOR ASSEMBLY. See Section 702.1.

FLY GALLERY. See Section 410.2.

[F] **FOAM-EXTINGUISHING SYSTEMS.** See Section 902.1.

FOAM PLASTIC INSULATION. See Section 2602.1.

FOLDING AND TELESCOPIC SEATING. See Section 1002.1.

FOOD COURT. See Section 402.2.

FOUNDATION PIER. See Section 2102.1.

FREE-STANDING PEDESTAL. [DSA-AC] See Chapter 11C, Section 1101C.1.

FULL-TIME CARE. See Section 310.

[F] **GAS CABINET.** See Section 415.2.

[F] **GAS ROOM.** See Section 415.2.

[F] **GASEOUS HYDROGEN SYSTEM.** See Section 420.2.

GLASS FIBERBOARD. See Section 721.1.1.

GLASS UNIT MASONRY. See Section 2102.1.

GLUED BUILT-UP MEMBER. See Section 2302.1.

GRAB BAR. [DSA-AC & HCD 1-AC] See Chapter 11A, Section 1107A.7-G, and Chapter 11B, Section 1102B.

GRADE (Adjacent Ground Elevation) [DSA-AC] [HCD 1-AC] is the lowest point of elevation of the finished surface of the ground, paving or sidewalk within the area between the building and the property line or, when the property line is more than 5 feet (1524 mm) from the building, between the building and a line 5 feet (1524 mm) from the building. See Health and Safety Code Section 19955.3(d).

GRADE FLOOR OPENING. A window or other opening located such that the sill height of the opening is not more than 44 inches (1118 mm) above or below the finished ground level adjacent to the opening.

GRADE (LUMBER). See Section 2302.1.

GRADE PLANE. See Section 502.1.

GRANDSTAND. See Section 1002.1.

GRIDIRON. See Section 410.2.

GROSS LEASABLE AREA. See Section 402.2.

GROUND FLOOR. [DSA-AC & HCD 1-AC] See Chapter 11A, Section 1107A.7-G.

GROUTED MASONRY. See Section 2102.1.

Grouted hollow-unit masonry. See Section 2102.1.

Grouted multiwythe masonry. See Section 2102.1.

GUARD [DSA-AC, HCD 1 & HCD 2] or GUARDRAIL. See Section 1002.1.

GYPSON BOARD. See Section 2502.1.

GYPSON PLASTER. See Section 2502.1.

GYPSON VENEER PLASTER. See Section 2502.1.

HABITABLE SPACE. A space in a building for living, sleeping, eating or cooking. Bathrooms, toilet rooms, closets, halls, storage or utility spaces and similar areas are not considered habitable spaces.

[F] **HALOGENATED EXTINGUISHING SYSTEMS.** See Section 902.1.

DEFINITIONS

[F] **HANDLING.** See Section 307.2.

HANDRAIL. See Section 1002.1.

HARDBOARD. See Section 2302.1.

[F] **HAZARDOUS MATERIALS.** See Section 307.2.

[F] **HAZARDOUS PRODUCTION MATERIAL (HPM).** See Section 415.2.

HAZARDOUS SUBSTANCE [SFM] is a substance which, by reason of being explosive, flammable, toxic, poisonous, corrosive, oxidizing, irritant or otherwise harmful, is likely to cause injury.

HEAD JOINT. See Section 2102.1.

HEADER (Bonder). See Section 2102.1.

HEALTH CARE PROVIDER. [DSA-AC] See “Professional Office of a Health Care Provider” in Chapter 11B, Section 1102B.

[F] **HEALTH HAZARD.** See Section 307.2.

HEIGHT, BUILDING. See Section 502.1.

HEIGHT, STORY. See Section 502.1.

HEIGHT, WALLS. See Section 2102.1.

HELIPORT. See Section 412.5.1.

HELISTOP. See Section 412.5.1.

[F] **HIGHLY TOXIC.** See Section 307.2.

HIGH-RISE BUILDING. [SFM] See Section 403.1.3.

HISTORICAL BUILDINGS. [DSA-AC] See “Qualified historical building or property,” C.C.R., Title 24, Part 8.

HORIZONTAL ASSEMBLY. See Section 702.1.

[F] **HPM FLAMMABLE LIQUID.** See Section 415.2.

[F] **HPM ROOM.** See Section 415.2.

HURRICANE-PRONE REGIONS. See Section 1609.2.

[F] **HYDROGEN CUTOFF ROOM.** See Section 420.2.

IF, IF... THEN. [DSA-AC] See Chapter 11B, Section 1102B.

IMMEDIATELY DANGEROUS TO LIFE AND HEALTH (IDLH). See Section 415.2.

IMPACT INSULATION CLASS (IIC). See Chapter 12, Section 1207.2.

IMPACT LOAD. See Section 1602.1.

INCOMPATIBLE MATERIALS. See Section 307.2.

INDEPENDENT ENTITY [DSA-AC] is a not-for-profit product safety testing and certification organization, dedicated to testing for public safety. An independent entity would operate for the testing, certification and quality assessment of products, systems and services.

INFANT. [SFM] See Section 310.

[F] **INITIATING DEVICE.** See Section 902.1.

INSPECTION CERTIFICATE. See Section 1702.1.

INTERIOR FINISH. See Section 802.1.

INTERIOR FLOOR FINISH. See Section 802.1.

INTERIOR SURFACES. See Section 2502.1.

INTERIOR WALL AND CEILING FINISH. See Section 802.1.

INTERLAYMENT. See Section 1502.1.

INTERNATIONAL SYMBOL OF ACCESSIBILITY. [DSA-AC & HCD 1-AC] See Chapter 11A, Section 1107A.9-I, and Chapter 11B, Section 1102B.

JOINT. See Section 702.1.

JURISDICTION. The governmental unit that has adopted this code under due legislative authority.

KICK PLATE. [DSA-AC & HCD 1-AC] See Chapter 11A, Section 1107A.11-K, and Chapter 11B, Section 1102B.

LABEL. See Section 1702.1.

LABORATORY. [SFM] A room, building or area where the use and storage of hazardous materials are utilized for testing, analysis, instruction, research or developmental activities.

LABORATORY SUITE. [SFM] See Section 443.2.

LEVEL ACCESSIBLE AREA. [DSA-AC] See Chapter 11C, Section 1101C.1.

LEVEL AREA. [DSA-AC & HCD 1-AC] See Chapter 11A, Section 1107A.12-L, and Chapter 11B, Section 1102B.

LIFT, PLATFORM (WHEELCHAIR). [DSA-AC & HCD 1-AC] See “Platform (Wheelchair) Lift” Chapter 11A, Section 1107A.16-P, and Chapter 11B, Section 1102B.

LIGHT-DIFFUSING SYSTEM. See Section 2602.1.

LIGHT-FRAME CONSTRUCTION. A type of construction whose vertical and horizontal structural elements are primarily formed by a system of repetitive wood or light gage steel framing members.

LIGHT-TRANSMITTING PLASTIC ROOF PANELS. See Section 2602.1.

LIGHT-TRANSMITTING PLASTIC WALL PANELS. See Section 2602.1.

LIMIT STATE. See Section 1602.1.

[F] **LIQUID.** See Section 415.2.

[F] **LIQUID STORAGE ROOM.** See Section 415.2.

[F] **LIQUID USE, DISPENSING AND MIXING ROOMS.** See Section 415.2.

LISTED. See Section 902.1.

[HCD 1 & 2] “Listed” means all products that appear in a list published by an approved testing or listing agency. For additional information, see Health and Safety Code Section 17920(h).

For applications listed in Section 111 regulated by the Office of the State Fire Marshal, “Listed” shall also mean equipment or materials accepted by the State Fire Marshal as conforming to the provisions of the State Fire Marshal’s regulations and which are included in a list published by the State Fire Marshal.

LISTING AGENCY [HCD 1 & 2] means an agency approved by the department that is in the business of listing and labeling

products, materials, equipment and installations tested by an approved testing agency, and that maintains a periodic inspection program on current production of listed products, equipment and installations, and that, at least annually, makes available a published report of these listings. For additional information, see Health and Safety Code Section 17920(i).

LIVE LOADS. See Section 1602.1.

LIVE LOADS (ROOF). See Section 1602.1.

LOAD AND RESISTANCE FACTOR DESIGN (LRFD). See Section 1602.1.

LOAD EFFECTS. See Section 1602.1.

LOAD FACTOR. See Section 1602.1.

LOADS. See Section 1602.1.

LOBBY [HCD 1, HCD 2 & SFM] is an area not defined as a waiting room at the entrance of a building through which persons must pass.

LODGING HOUSE [HCD 1] is any building or portion thereof containing not more than five guest rooms where rent is paid in money, goods, labor or otherwise.

LOT. A portion or parcel of land considered as a unit.

LOT LINE. A line dividing one lot from another, or from a street or any public place.

[F] LOWER FLAMMABLE LIMIT (LFL). See Section 415.2.

LOWEST FLOOR. See Section 1612.2.

MAIN WINDFORCE-RESISTING SYSTEM. See Section 1702.1.

MALL. See Section 402.2.

[F] MANUAL FIRE ALARM BOX. See Section 902.1.

MANUFACTURER'S DESIGNATION. See Section 1702.1.

MARK. See Section 1702.1.

MARKED CROSSING. [DSA-AC & HCD 1-AC] See Chapter 11A, Section 1107A.13-M, and Chapter 11B, Section 1102B.

MARQUEE. A permanent roofed structure attached to and supported by the building and that projects into the public right-of-way.

MASONRY. See Section 2102.1.

Ashlar masonry. See Section 2102.1.

Coursed ashlar. See Section 2102.1.

Glass unit masonry. See Section 2102.1.

Plain masonry. See Section 2102.1.

Random ashlar. See Section 2102.1.

Reinforced masonry. See Section 2102.1.

Solid masonry. See Section 2102.1.

Unreinforced (plain) masonry. See Section 2102.1.

MASONRY UNIT. See Section 2102.1.

Clay. See Section 2102.1.

Concrete. See Section 2102.1.

Hollow. See Section 2102.1.

Solid. See Section 2102.1.

MAXIMUM CONSIDERED EARTHQUAKE GROUND MOTION. See Section 1613.2.

MAY. [DSA-AC] See Chapter 11B, Section 1102B.

MEAN DAILY TEMPERATURE. See Section 2102.1.

MEANS OF EGRESS. See Section 1002.1.

MECHANICAL-ACCESS OPEN PARKING GARAGES. See Section 406.3.2.

MECHANICAL EQUIPMENT SCREEN. See Section 1502.1.

MECHANICAL SYSTEMS. See Section 1613.2.

MEMBRANE-COVERED CABLE STRUCTURE. See Section 3102.2.

MEMBRANE-COVERED FRAME STRUCTURE. See Section 3102.2.

MEMBRANE PENETRATION. See Section 702.1.

MEMBRANE-PENETRATION FIRESTOP. See Section 702.1.

MENTALLY RETARDED PERSONS, PROFOUNDLY OR SEVERELY. See Section 310.

MERCHANDISE PAD. See Section 1002.1.

METAL COMPOSITE MATERIAL (MCM). See Section 1402.1.

METAL COMPOSITE MATERIAL (MCM) SYSTEM. See Section 1402.1.

METAL ROOF PANEL. See Section 1502.1.

METAL ROOF SHINGLE. See Section 1502.1.

MEZZANINE. See Section 502.1.

MICROPILES. See Section 1808.1.

MINERAL BOARD. See Section 721.1.1.

MINERAL FIBER. See Section 702.1.

MINERAL WOOL. See Section 702.1.

MODERNIZATION PROJECT [SFM] is any construction effort that has an estimated total cost in excess of \$200,000 that is intended to modify a permanent school building or structure and/or the addition of a new school building or structure used to serve or house students from kindergarten through 12th grade (K-12). Modernization efforts shall apply strictly to a public school that was established prior to July 1, 2002, and is funded pursuant to the Education Code, Section 17074.56, and Education Code commencing with Section 17070.10. Modernization projects that are to be completed in more than one phase may defer the installation of the automatic fire detection and alarm systems until the final phase of the modernization project. Solely for the purposes of Education Code Section 17074.20, routine maintenance and repair work shall not be considered a modernization project.

DEFINITIONS

MODIFIED BITUMEN ROOF COVERING. See Section 1502.1.

MORTAR. See Section 2102.1.

MORTAR, SURFACE-BONDING. See Section 2102.1.

MOTION PICTURE AND TELEVISION PRODUCTION STUDIO SOUND STAGES, APPROVED PRODUCTION FACILITIES AND PRODUCTION LOCATIONS. See Chapter 46, California Fire Code.

MULTILEVEL ASSEMBLY SEATING. See Section 1102.1.

MULTIPLE-ACCOMMODATION TOILET FACILITY [DSA-AC] is a room that has more than one sanitary fixture, is intended for the use of more than one person at a time and which usually is provided with privacy compartments or screens shielding some fixtures from view. A bathroom serving a hotel guest room and a privacy toilet in small offices, stores and similar locations are not included in this category.

[F] MULTIPLE-STATION ALARM DEVICE. See Section 902.1.

[F] MULTIPLE-STATION SMOKE ALARM. See Section 902.1.

MULTISTORY DWELLING UNIT. [DSA-AC & HCD 1-AC] See Chapter 11A, Section 1107A.13-M.

NAILING, BOUNDARY. See Section 2302.1.

NAILING, EDGE. See Section 2302.1.

NAILING, FIELD. See Section 2302.1.

NATURALLY DURABLE WOOD. See Section 2302.1.

Decay resistant. See Section 2302.1.

Termite resistant. See Section 2302.1.

NEWLY CONSTRUCTED. [DSA-AC & HCD 1-AC] See Chapter 11A, Section 1107A.14-N.

NEW PUBLIC SCHOOL CAMPUS [SFM] is an educational institution established on or after July 1, 2002 that houses and/or serves students from kindergarten through 12th grade (K-12) and is funded pursuant to the Education Code, commencing with Section 17070.10.

NFPA [DSA-AC] is the National Fire Protection Association.

NONAMBULATORY PERSONS. See Section 310.

NONCOMBUSTIBLE, [SFM] as applied to building construction material, means a material which, in the form in which it is used, is either one of the following:

1. Material of which no part will ignite and burn when subjected to fire. Any material passing ASTM E 136 shall be considered noncombustible.
2. Material having a structural base of noncombustible material as defined in Item 1 above, with a surfacing material not over $\frac{1}{8}$ inch (3.2 mm) thick which has a flame-spread rating of 50 or less.

“Noncombustible” does not apply to surface finish materials. Material required to be noncombustible for reduced clearances to flues, heating appliances or other sources of high temperature shall refer to material conforming to Item 1. No

material shall be classed as noncombustible, which is subject to increase in combustibility or flame spread rating, beyond the limits herein established, through the effects of age, moisture or other atmospheric condition.

NOMINAL LOADS. See Section 1602.1.

NOMINAL SIZE. (LUMBER). See Section 2302.1.

NONCOMBUSTIBLE MEMBRANE STRUCTURE. See Section 3102.2.

NORMAL [HCD 1 & HCD 2] shall mean conforming to a pattern or standard regarded as usual or typical.

[F] NORMAL TEMPERATURE AND PRESSURE (NTP). See Section 415.2.

NOSING (or NOSE). See Section 1002.1. [DSA-AC & HCD 1-AC] See Chapter 11A, Section 1107A.14-N and Chapter 11B, Section 1102B.

[F] NUISANCE ALARM. See Section 902.1.

OCCUPANCY CATEGORY. See Section 1602.1.

OCCUPANT LOAD. See Section 1002.1.

OCCUPIABLE SPACE. A room or enclosed space designed for human occupancy in which individuals congregate for amusement, educational or similar purposes or in which occupants are engaged at labor, and which is equipped with means of egress and light and ventilation facilities meeting the requirements of this code.

OPEN PARKING GARAGE. See Section 406.3.2.

OPEN RISER. [DSA-AC & HCD 1-AC] See Chapter 11A, Section 1107A.15-O, and Chapter 11B, Section 1102B.

[F] OPEN SYSTEM. See Section 307.2.

OPERABLE PART. [DSA-AC] See Chapter 11B, Section 1102B.

OPERATING BUILDING. See Section 307.2.

ORDINARY PRECAST STRUCTURAL WALL. See Section 1908.1.3.

ORDINARY REINFORCED CONCRETE STRUCTURAL WALL. See Section 1908.1.3.

ORDINARY STRUCTURAL PLAIN CONCRETE WALL. See Section 1908.1.3.

[F] ORGANIC PEROXIDE. See Section 307.2.

Class I. See Section 307.2.

Class II. See Section 307.2.

Class III. See Section 307.2.

Class IV. See Section 307.2.

Class V. See Section 307.2.

Unclassified detonable. See Section 307.2.

ORGANIZED CAMPS. [SFM] See Section 440.

ORTHOGONAL. See Section 1613.2.

OTHER STRUCTURES. See Section 1602.1.

OWNER. Any person, agent, firm or corporation having a legal or equitable interest in the property.

[F] OXIDIZER. See Section 307.2.

Class 4. See Section 307.2.

Class 3. See Section 307.2.

Class 2. See Section 307.2.

Class 1. See Section 307.2.

[F] OXIDIZING GAS. See Section 307.2.

PANEL (PART OF A STRUCTURE). See Section 1602.1.

PANIC HARDWARE. See Section 1002.1.

PARTICLEBOARD. See Section 2302.1.

PASSAGE DOOR. [DSA-AC & HCD 1-AC] See Chapter 11A, Section 1107A.16-P, and Chapter 11B, Section 1102B.

PASSENGER ELEVATOR. [DSA-AC] See “Elevator, passenger” in Chapter 11B, Section 1102B.

[HCD 1 & HCD 2] “Passenger elevator” is an elevator used primarily to carry persons. For additional information, see California Code of Regulations, Title 24, Part 7, Article 7-6, Section 3009 of the 2001 California Building Code.

PASSIVE SOLAR ENERGY COLLECTOR [HCD 1] uses architectural components, rather than mechanical components, to provide heating or cooling for a building interior.

PATH OF TRAVEL. [DSA-AC] See Chapter 11B, Section 1102B.

PEDESTRIAN. [DSA-AC & HCD 1-AC] See Chapter 11A, Section 1107A.16-P, and Chapter 11B, Section 1102B.

PEDESTRIAN GRADE SEPARATION. [DSA-AC] See Chapter 11B, Section 1102B.

PEDESTRIAN RAMP. [DSA-AC & HCD 1-AC] See Chapter 11A, Section 1107A.16-P, and Chapter 11B, Section 1102B.

PEDESTRIAN WAY. [DSA-AC & HCD 1-AC] See Chapter 11A, Section 1107A, 16-P, and Chapter 11B, Section 1102B.

PENETRATION FIRESTOP. See Section 702.1.

PENTHOUSE. See Section 1502.1.

PERMANENT [DSA-AC] shall mean facilities which, are intended to be used for periods longer than those designated in this code under the definition of “Temporary.”

PERMANENT PORTABLE BUILDING [SFM] is a portable building that is used to serve or house students and is certified as a permanent building on a new public school campus by the public school administration shall comply with the requirements of new campus buildings.

PERMIT. An official document or certificate issued by the authority having jurisdiction which authorizes performance of a specified activity.

PERSON. An individual, heirs, executors, administrators or assigns, and also includes a firm, partnership or corporation, its or their successors or assigns, or the agent of any of the aforesaid.

PERSONAL CARE SERVICE. See Section 310.2.

PERSONS WITH DISABILITIES. [DSA-AC & HCD 1-AC] See Chapter 11A, Section 1107A.16-P.

PHOTOLUMINESCENT. [SFM] See Section 1002.

[F] PHYSICAL HAZARD. See Section 307.2.

[F] PHYSIOLOGICAL WARNING THRESHOLD LEVEL. See Section 415.2.

PIER FOUNDATIONS. See Section 1808.1.

Belled piers. See Section 1808.1.

PILE FOUNDATIONS. See Section 1808.1.

Auger uncased piles. See Section 1808.1.

Caisson piles. See Section 1808.1.

Concrete-filled steel pipe and tube piles. See Section 1808.1.

Driven uncased piles. See Section 1808.1.

Enlarged base piles. See Section 1808.1.

Steel-cased piles. See Section 1808.1.

Timber piles. See Section 1808.1.

PINRAIL. See Section 410.2.

PLASTIC, APPROVED. See Section 2602.1.

PLASTIC GLAZING. See Section 2602.1.

PLASTIC HINGE. See Section 2102.1.

PLATFORM. See Section 410.2.

PLATFORM (WHEELCHAIR) LIFT. [DSA-AC & HCD 1-AC] See Chapter 11A, Section 1107A.16-P, and Chapter 11B, Section 1102B.

PORTABLE BUILDING [SFM] is a classroom building or structure of modular design and construction that houses and/or serves students from kindergarten through twelfth grade (K-12) and is funded pursuant to the Education Code, commencing with Section 17070.10 and meets all of the following criteria:

- The portable building or structure is designed and constructed to be relocatable and transportable over public streets.
- The portable building or structure is designed and constructed for relocation without detaching the roof or the floor from the building or structure.
- The portable building or structure is sited upon a temporary foundation in a manner that is designed to permit easy removal.
- The portable building or structure has a floor area of 2,000 square feet (186 m²) or less when measured from the extent of the exterior walls.
- The portable building shall be removed within three years of installation or the school administration may request a three-year extension pursuant to Education Code Section 17074.54(a) and (b).

POSITIVE ROOF DRAINAGE. See Section 1502.1.

POWDER ROOM. [DSA-AC & HCD 1-AC] See Chapter 11A, Section 1107A.16-P.

POWER-ASSISTED DOOR [DSA-AC] is a door used for human passage with a mechanism that helps to open the door;

DEFINITIONS

or relieves the opening resistance of a door, upon the activation of a switch or a continued force applied to the door itself.

PREFABRICATED WOOD I-JOIST. See Section 2302.1.

PRESERVATIVE-TREATED WOOD. See Section 2302.1.

PRESTRESSED MASONRY. See Section 2102.1.

PRIMARY ENTRY. [HCD 1-AC] See Chapter 11A, Section 1107A.16-P.

PRIMARY ENTRY LEVEL. [HCD 1-AC] See Chapter 11A, Section 1107A.16-P.

PRIMARY FUNCTION. See Section 3402.1.

PRISM. See Section 2102.1.

PROFESSIONAL OFFICE OF A HEALTH CARE PROVIDER. [DSA-AC] See Chapter 11B, Section 1102B.

PROSCENIUM WALL. See Section 410.2.

PROTECTIVE SOCIAL CARE [SFM] is the housing and care of any person of any age when such person is referred to or placed within such home or facility for care and supervision services by any governmental agency.

PUBLIC ACCOMMODATION [DSA-AC, HCD 1 & HCD 2] includes, but is not limited to, any public use building or facility that may be classified into one or more of the following categories:

1. Places of public lodging.
2. Establishments serving food or drink open to public use.
3. Places of exhibition or entertainment open to public use.
4. Places of public gathering.
5. Sales or rental establishments open to public use.
6. Service establishments open to public use.
7. Stations used for public transportation.
8. Places of public display or collection.
9. Places of public recreation.
10. Places of public education.
11. Social service center establishments open to public use.
12. Places of exercise or recreation open to public use.

Examples of public accommodations for purposes of this code shall include, but not be limited to, the following private entities:

1. An inn, hotel, motel or other place of public lodging, except for a lodging house located within a building that contains not more than five rooms for rent or hire and that is actually occupied by the proprietor of such establishment as the residence of such proprietor.
2. A restaurant, bar or other establishment serving food or drink.
3. A motion picture house, theater, concert hall, stadium or other place of exhibition or entertainment.
4. An auditorium, convention center, lecture hall or other place of public gathering.

5. A bakery, grocery store, clothing store, hardware store, shopping center, or other sales or rental establishment.

6. A laundromat, dry cleaner, bank, barber shop, beauty shop, travel service, shoe repair service, funeral parlor, gas station, office of an accountant or lawyer, pharmacy, insurance office, professional office of a health care provider, hospital or other service establishment.

7. A terminal, depot or other station used for specified public transportation.

8. A museum, library, gallery or other place of public display or collection.

9. A park, zoo, amusement park or other place of recreation.

10. A nursery, elementary, secondary, undergraduate or postgraduate private school, or other place of education.

11. A day care center, senior citizen center, homeless shelter, food bank, adoption agency or other social service center establishment.

12. A gymnasium, health spa, bowling alley, golf course or other place of exercise.

13. A church.

14. An office building.

15. A public curb or sidewalk.

PUBLIC ENTRANCE [HCD 1-AC] is an entrance that is not a service entrance or a restricted entrance.

PUBLIC-USE AREAS. [DSA-AC & HCD 1-AC] See Chapter 11A, Section 1107A.16-P, and Chapter 11B, Section 1102B.

PUBLIC WAY. See Section 1002.1.

PUBLICLY FUNDED [DSA-AC, HCD 1 & HCD 2] for the purpose of housing, all buildings, structures, sidewalks, curbs and related facilities constructed in the state and used or intended to be used as a public use area, as defined in Section 1107A.16-P, shall comply with the accessibility standards of Chapter 11B of this code when state, county or municipal funds, or funds of any political subdivision of the state are used.

[F] PYROPHORIC. See Section 307.2.

[F] PYROTECHNIC COMPOSITION. See Section 307.2.

QUALIFIED HISTORICAL BUILDING (or PROPERTY). [DSA-AC] See C.C.R. Title 24, Part 8.

RAIL TRANSIT BOARDING PLATFORM. [DSA-AC] See "transit boarding platform" in Chapter 11B, Section 1102B.

RAMP. See Section 1002.1.

[DSA-AC & HCD 1-AC] See Chapter 11A, Section 1107A.18-R and Chapter 11B, Section 1102B.

RAMP-ACCESS OPEN PARKING GARAGES. See Section 406.3.2.

REASONABLE PORTION [DSA-AC] shall mean that segment of a building, facility, area, space or condition, which would normally be necessary if the activity therein is to be accessible by persons with disabilities.

RECOMMEND [DSA-AC, HCD 1 & HCD 2] does not require mandatory acceptance, but identifies a suggested action that shall be considered for the purpose of providing a greater degree of accessibility to persons with disabilities.

[F] RECORD DRAWINGS. See Section 902.1.

REFERENCE RESISTANCE (D). See Section 2302.1.

REGISTERED DESIGN PROFESSIONAL. An individual who is registered or licensed to practice their respective design profession as defined by the statutory requirements of the professional registration laws of the state or jurisdiction in which the project is to be constructed.

REINFORCED PLASTIC, GLASS FIBER. See Section 2602.1.

RELIGIOUS WORSHIP, PLACE OF. A building or portion thereof intended for the performance of religious services.

REMODELING. [DSA-AC] See “Alteration or Alter.”

REPAIR. The reconstruction or renewal of any part of an existing building for the purpose of its maintenance.

REQUIRED STRENGTH. See Sections 1602.1 and 2102.1.

REROOFING. See Section 1502.1.

RESIDENTIAL AIRCRAFT HANGAR. See Section 412.3.1.

RESIDENTIAL CARE/ASSISTED LIVING FACILITIES. See Section 310.2.

RESIDENTIAL CARE FACILITY FOR THE CHRONICALLY ILL (RCF/CI). See Section 310.

RESIDENTIAL CARE FACILITY FOR THE ELDERLY (RCFE). See Section 310.

RESIDENTIAL FACILITY (RF). See Section 310.

RESISTANCE FACTOR. See Section 1602.1.

RESTRAINT [SFM] shall mean the physical retention of a person within a room, cell or cell block by any means, or within the exterior walls of a building by means of locked doors inoperable by the person restrained. “Restraint” shall also mean the physical binding, strapping or similar restriction of any person in a chair, walker, bed or other contrivance for the purpose of deliberately restricting the free movement of ambulatory persons.

“Restraint” shall not be construed to include nonambulatory persons nor shall it include the use of bandage material, strip sheeting or other fabrics or materials (soft ties) used to restrain persons in hospital-type beds or wheelchairs to prevent injury, provided an approved method of quick release is maintained. Facilities employing the use of soft ties, however, shall be classified as a building used to house nonambulatory persons.

“Restraint” shall not be practiced in licensed facilities classified as Group I-1, R-3.1 and R-4 occupancies unless constructed as a Group I-3 occupancy. For Group I-3 occupancies see Section 308.2.

RESTRICTED ENTRANCE [HCD 1, HCD 2 & HCD 1-AC] is an entrance that is made available for common use on

a controlled basis, but is not public use, and that is not a service entrance.

RETRACTABLE AWNING. See Section 3105.2.

RISER. [DSA-AC, HCD 1 & HCD 2] See Chapter 11A, Section 1107A.18-R, and Chapter 11B, Section 1102B.

ROOF ASSEMBLY. See Section 1502.1.

ROOF COVERING. See Section 1502.1.

ROOF COVERING SYSTEM. See Section 1502.1.

ROOF DECK. See Section 1502.1.

ROOF RECOVER. See Section 1502.1.

ROOF REPAIR. See Section 1502.1.

ROOF REPLACEMENT. See Section 1502.1.

ROOF VENTILATION. See Section 1502.1.

ROOFTOP STRUCTURE. See Section 1502.1.

RUBBLE MASONRY. See Section 2102.1.

Coursed rubble. See Section 2102.1.

Random rubble. See Section 2102.1.

Rough or ordinary rubble. See Section 2102.1.

RUNNING BOND. See Section 2102.1.

RUNNING SLOPE. [DSA-AC] See Chapter 11B, Section 1102B.

SANITARY FACILITY [DSA-AC, HCD 1 & HCD 2] is any single water closet, urinal, lavatory, bathtub or shower, or a combination thereof, together with the room or space in which they are housed.

SCISSOR STAIR. See Section 1002.1.

SCUPPER. See Section 1502.1.

SEISMIC DESIGN CATEGORY. See Section 1613.2.

SEISMIC-FORCE-RESISTING SYSTEM. See Section 1613.2.

SELF-CLOSING. See Section 702.1.

SELF-LUMINOUS. See Section 1002.

[F] SERVICE CORRIDOR. See Section 415.2.

SERVICE ENTRANCE [DSA-AC & HCD 1-AC] is an entrance intended primarily for the delivery of goods or services.

SHAFT. See Section 702.1.

SHAFT ENCLOSURE. See Section 702.1.

SHALL [DSA-AC]. See Chapter 11B, Section 1102B.

SHEAR WALL. See Sections 2102.1 and 2302.1.

Detailed plain masonry shear wall. See Section 2102.1.

Intermediate prestressed masonry shear wall. See Section 2102.1.

Intermediate reinforced masonry shear wall. See Section 2102.1.

Ordinary plain masonry shear wall. See Section 2102.1.

DEFINITIONS

Ordinary plain prestressed masonry shear wall. See Section 2102.1.

Ordinary reinforced masonry shear wall. See Section 2102.1.

Perforated shear wall. See Section 2302.1.

Perforated shear wall segment. See Section 2302.1.

Special prestressed masonry shear wall. See Section 2102.1.

Special reinforced masonry shear wall. See Section 2102.1.

SHELL. See Section 2102.1.

SHOPPING CENTER (or SHOPPING MALL). [DSA-AC & HCD 2] See Chapter 11B, Section 1102B.

SHOULD. [HCD 1 & HCD 2] See "Recommend." [DSA-AC] See Chapter 11B, Section 1102B.

SIDEWALK [DSA-AC & HCD 1-AC] is a surfaced pedestrian way contiguous to a street used by the public. (As differentiated from the definition of "Walk" in Chapter 11A, Section 1107A.23-W, and Chapter 11B, Section 1102B.)

SIGNAGE [DSA-AC] is displayed verbal, symbolic, tactile, and/or pictorial information.

SINGLE-ACCOMMODATION SANITARY FACILITY [DSA-AC, HCD 1 & HCD 2] is a room that has not more than one of each type of sanitary fixture, is intended for use by only one person at a time, has no partition around the toilet and has a door that can be locked on the inside by the room occupant.

SINGLE-PLY MEMBRANE. See Section 1502.1.

[F] SINGLE-STATION SMOKE ALARM. See Section 902.1.

SITE [DSA-AC, HCD 1 & HCD 2] is a parcel of land bounded by a property line or a designated portion of a public right-of-way.

SITE CLASS. See Section 1613.2.

SITE COEFFICIENTS. See Section 1613.2.

SITE DEVELOPMENT [DSA-AC & HCD 1-AC] is "on-site" and "off-site" work, including, but not limited to, walks, sidewalks, ramps, curbs, curb ramps, parking facilities, stairs, planting areas, pools, promenades, exterior gathering or assembly areas and raised or depressed paved areas.

SKYLIGHT, UNIT. A factory-assembled, glazed fenestration unit, containing one panel of glazing material that allows for natural lighting through an opening in the roof assembly while preserving the weather-resistant barrier of the roof.

SKYLIGHTS AND SLOPED GLAZING. Glass or other transparent or translucent glazing material installed at a slope of 15 degrees (0.26 rad) or more from vertical. Glazing material in skylights, including unit skylights, solariums, sunrooms, roofs and sloped walls, are included in this definition.

SLEEPING ACCOMMODATIONS. [DSA-AC & HCD 1-AC] See Chapter 11A, Section 1107A.19-S, and Chapter 11B, Section 1102B.

SLEEPING UNIT. A room or space in which people sleep, which can also include permanent provisions for living, eating, and either sanitation or kitchen facilities but not both. Such rooms and spaces that are also part of a dwelling unit are not sleeping units.

SLOPE. [DSA-AC & HCD 1-AC] See Chapter 11A, Section 1107A.19-S.

[F] SMOKE ALARM. See Section 902.1.

SMOKE BARRIER. See Section 702.1.

SMOKE COMPARTMENT. See Section 702.1.

SMOKE DAMPER. See Section 702.1.

[F] SMOKE DETECTOR. See Section 902.1.

SMOKE-DEVELOPED INDEX. See Section 802.1.

SMOKE-PROTECTED ASSEMBLY SEATING. See Section 1002.1.

SMOKEPROOF ENCLOSURE. See Section 902.1.

[F] SOLID. See Section 415.2.

SOUND TRANSMISSION CLASS (STC). [HCD 1] See Chapter 12, Section 1207.2.

SPACE [DSA-AC & HCD 2] is a definable area, e.g., a room, toilet room, hall, assembly area, entrance, storage room, alcove, courtyard, or lobby.

SPECIAL AMUSEMENT BUILDING. See Section 411.2.

SPECIAL INSPECTION. See Section 1702.1.

Special inspection, continuous. See Section 1702.1.

Special inspection, periodic. See Section 1702.1.

SPECIAL FLOOD HAZARD AREA. See Section 1612.2.

SPECIFIED. See Section 2102.1.

SPECIFIED COMPRESSIVE STRENGTH OF MASONRY (f'_m). See Section 2102.1.

SPECIFIED PUBLIC TRANSPORTATION. [DSA-AC] See Chapter 11B, Section 1102B.

SPLICE. See Section 702.1.

SPRAYED FIRE-RESISTANT MATERIALS. See Section 1702.1.

STACK BOND. See Section 2102.1.

STAGE. See Section 410.2.

STAIR. See Section 1002.1.

STAIRWAY. See Section 1002.1.

STAIRWAY, EXTERIOR. See Section 1002.1.

STAIRWAY, INTERIOR. See Section 1002.1.

STAIRWAY, SPIRAL. See Section 1002.1.

[F] STANDPIPE SYSTEM, CLASSES OF. See Section 902.1.

Class I system. See Section 902.1.

Class II system. See Section 902.1.

Class III system. See Section 902.1.

[F] STANDPIPE, TYPES OF. See Section 902.1.

Automatic dry. See Section 902.1.

Automatic wet. See Section 902.1.

Manual dry. See Section 902.1.

Manual wet. See Section 902.1.

Semiautomatic dry. See Section 902.1.

START OF CONSTRUCTION. See Section 1612.2.

STATE-OWNED/LEASED BUILDING [SFM] is a building or portion of a building that is owned, leased or rented by the state. State-leased buildings shall include all required exits to a public way serving such leased area or space. Portions of state-leased buildings that are not leased or rented by the state shall not be included within the scope of this section unless such portions present an exposure hazard to the state-leased area or space.

STEEL CONSTRUCTION, COLD-FORMED. See Section 2202.1.

STEEL JOIST. See Section 2202.1.

STEEL MEMBER, STRUCTURAL. See Section 2202.1.

STEEP SLOPE. A roof slope greater than two units vertical in 12 units horizontal (17-percent slope).

STONE MASONRY. See Section 2102.1.

Ashlar stone masonry. See Section 2102.1.

Rubble stone masonry. See Section 2102.1.

[F] STORAGE, HAZARDOUS MATERIALS. See Section 415.2.

STORY. The portion of a building included between the upper surface of a floor and the upper surface of the floor or roof next above (also see “Mezzanine” and Section 502.1). It is measured as the vertical distance from top to top of two successive tiers of beams or finished floor surfaces and, for the topmost story, from the top of the floor finish to the top of the ceiling joists, or where there is not a ceiling, to the top of the roof rafters.

[DSA-AC] See Chapter 11B, Section 1102B.

STORY ABOVE GRADE PLANE. Any story having its finished floor surface entirely above grade plane, except that a basement shall be considered as a story above grade plane where the finished surface of the floor above the basement is:

1. More than 6 feet (1829 mm) above grade plane; or
2. More than 12 feet (3658 mm) above the finished ground level at any point.

STORY, FIRST. *[DSA-AC] See Chapter 11B, Section 1102B.*

STRENGTH. See Section 2102.1.

Design strength. See Section 2102.1.

Nominal strength. See Sections 1602.1 and 2102.1.

Required strength. See Sections 1602.1 and 2102.1.

STRENGTH DESIGN. See Section 1602.1.

STRUCTURAL COMPOSITE LUMBER. See Section 2302.1.

Laminated veneer lumber (LVL). See Section 2302.1.

Parallel strand lumber (PSL). See Section 2302.1.

STRUCTURAL FRAME. *[DSA-AC] See Chapter 11B, Section 1102B.*

STRUCTURAL GLUED-LAMINATED TIMBER. See Section 2302.1.

STRUCTURAL OBSERVATION. See Section 1702.1.

STRUCTURE. That which is built or constructed.

SUBDIAPHRAGM. See Section 2302.1.

SUBSTANTIAL DAMAGE. See Section 1612.2.

SUBSTANTIAL IMPROVEMENT. See Section 1612.2.

SUNROOM ADDITION. See Section 1202.1.

[F] SUPERVISING STATION. See Section 902.1.

[F]SUPERVISORY SERVICE. See Section 902.1.

[F] SUPERVISORY SIGNAL. See Section 902.1.

[F] SUPERVISORY SIGNAL-INITIATING DEVICE. See Section 902.1.

SWIMMING POOLS. See Section 3109.2.

T RATING. See Section 702.1.

TACTILE [DSA-AC & HCD 2] describes an object that can be perceived using the sense of touch.

TECHNICALLY INFEASIBLE. See Section 3402.

[DSA-AC] “Technically infeasible” means, with respect to an alteration of a building or a facility, that it has little likelihood of being accomplished because existing structural conditions would require removing or altering a load-bearing member which is an essential part of the structural frame; or because other existing physical or site constraints prohibit modification or addition of elements, spaces or features which are in full and strict compliance with the minimum requirements for new construction and which are necessary to provide accessibility.

TEMPORARY [DSA-AC] shall mean buildings and facilities intended for use at one location for not more than one year and seats intended for use at one location for not more than 90 days.

TENT. Any structure, enclosure or shelter which is constructed of canvas or pliable material supported in any manner except by air or the contents it protects.

TERMINALLY ILL. See Section 310.

TESTING AGENCY [HCD-1 & HCD- 2] means an agency approved by the department as qualified and equipped for testing products, materials, equipment and installations in accordance with nationally recognized standards. For additional information, see Health and Safety Code Section 17920(m).

TEXT TELEPHONE. *[DSA-AC] See Chapter 11B, Section 1102B.*

THERMAL ISOLATION. See Section 1202.1.

THERMOPLASTIC MATERIAL. See Section 2602.1.

DEFINITIONS

THERMOSETTING MATERIAL. See Section 2602.1.

THIN-BED MORTAR. See Section 2102.1.

THROUGH PENETRATION. See Section 702.1.

THROUGH-PENETRATION FIRESTOP SYSTEM. See Section 702.1.

TIE-DOWN (HOLD-DOWN). See Section 2302.1.

TIE, LATERAL. See Section 2102.1.

TIE, WALL. See Section 2102.1.

TILE. See Section 2102.1.

TILE, STRUCTURAL CLAY. See Section 2102.1.

[F] TIRES, BULK STORAGE OF. See Section 902.1.

> **TOWNHOUSE.** A single-family dwelling unit constructed in a group of three or more attached units in which each unit extends from foundation to roof and with open space on at least two sides.

> **[F] TOXIC.** See Section 307.2.

TRANSIENT. See Section 310.2.

TRANSIENT LODGING. [DSA-AC & HCD 1-AC] See Chapter 11B, Section 1102B and Chapter 11A, Section 1107A.20-T.

TRANSIT BOARDING PLATFORM. [DSA-AC] See Chapter 11B, Section 1102B.

TREAD. [DSA-AC & HCD 1-AC] See Chapter 11A, Section 1107A.20-T, and Chapter 11B, Section 1102B.

TREAD DEPTH. [DSA-AC & HCD 1-AC] See Chapter 11A, Section 1107A.20-T, and Chapter 11B, Section 1102B.

TREAD RUN. [DSA-AC & HCD 1-AC] See Chapter 11A, Section 1107A.20-T, and Chapter 11B, Section 1102B.

TREATED WOOD. See Section 2302.1.

TRIM. See Section 802.1.

[F] TROUBLE SIGNAL. See Section 902.1.

TYPE OF MOTOR FUEL. [DSA-AC] See Chapter 11C, Section 1101C.1.

UNDERLAYMENT. See Section 1502.1.

UNREASONABLE HARDSHIP [DSA-AC] exists when the enforcing agency finds that compliance with the building standard would make the specific work of the project affected by the building standard unfeasible, based on an overall evaluation of the following factors:

1. The cost of providing access.
2. The cost of all construction contemplated.
3. The impact of proposed improvements on financial feasibility of the project.
4. The nature of the accessibility which would be gained or lost.
5. The nature of the use of the facility under construction and its availability to persons with disabilities.

The details of any finding of unreasonable hardship shall be recorded and entered in the files of the enforcing agency.

[F] UNSTABLE (REACTIVE) MATERIAL. See Section 307.2.

Class 4. See Section 307.2.

Class 3. See Section 307.2.

Class 2. See Section 307.2.

Class 1. See Section 307.2.

[F] USE (MATERIAL). See Section 415.2.

(TEXT CONTINUES ON PAGE 45)

**CALIFORNIA BUILDING CODE – MATRIX ADOPTION TABLE
CHAPTER 3 – USE AND OCCUPANCY CLASSIFICATION**

Adopting Agency	BSC	SFM	HCD			DSA		OSHPD				CSA	DHS	AGR	DWR	CEC	CA	SL	SLC
			1	2	1/AC	AC	SS	1	2	3	4								
Adopt Entire Chapter	X						X ◆	X	X	X	X								
Adopt Entire Chapter as amended (amended sections listed below)		X	X ◆	X ◆															
Adopt only those sections that are listed below			X	X	X														
Chapter / Section	Codes																		
302.1	IBC					X													
302.1	CA	X																	
302.1.4	CA	X																	
303.1	CA	X																	
303.2	CA	X																	
303.3	CA	X																	
304.1	CA	X																	
305.1	CA	X																	
305.2	CA	X																	
306.2	CA	X																	
307.1	CA	X																	
Table 307.1 (1)	CA	X																	
Table 307.1 (2)	CA	X																	
308.1	CA	X																	
308.2	IBC		X	X															
308.2	CA	X																	
308.3	IBC		X	X															
308.3	CA	X																	
308.3.1	CA	X																	
308.3.2	CA	X																	
308.4	CA	X																	
308.4.6	CA	X																	
Cell	CA	X																	
Cell Complex	CA	X																	
Cell Tiers	CA	X																	
Day Room	CA	X																	
Dormitory	CA	X																	
Holding Facility	CA	X																	
Housing Unit	CA	X																	
Restraint	CA	X																	
308.5	IBC		X	X															
308.5	CA	X																	
308.5.1	CA	X																	
308.5.2	CA	X																	
308.5.2.1	CA	X																	
310.1	IBC		X	X															
310.1	CA	X																	
310.2	CA																		
310.2	IBC																		
310.2 (Dormitory)	IBC					X													
Aged Home or Institution	CA	X																	
Bedridden Person	CA	X																	
Boarding House	IBC																		

CHAPTER 3 – USE AND OCCUPANCY CLASSIFICATION (Continued)

Adopting Agency	BSC	SFM	HCD			DSA		OSHPD				CSA	DHS	AGR	DWR	CEC	CA	SL	SLC
			1	2	1/AC	AC	SS	1	2	3	4								
Adopt Entire Chapter	X						X ◆	X	X	X	X								
Adopt Entire Chapter as amended (amended sections listed below)		X	X ◆	X ◆															
Adopt only those sections that are listed below			X	X	X														
Chapter / Section	Codes																		
Care and Supervision	CA	X																	
Catastrophically Injured	CA	X																	
Child-Care Center	CA	X																	
Child or Children	CA	X																	
Chronically Ill	CA	X																	
Congregate Living Health (CLHF)	CA	X																	
Day care	CA	X																	
Day-Care Home, Large Family	CA	X																	
Day-Care Home, Small Family	CA	X																	
Full-Time Care	CA	X																	
Infant	CA	X																	
Mentally Retarded Persons, Profoundly or Severely	CA	X																	
Nonambulatory Persons	CA	X																	
Residential Care Facility for the Chronically Ill (RCF/CI)	CA	X																	
Residential Care Facility for the Elderly (RCFE)	CA	X																	
Residential Facility (RF)	CA	X																	
Terminally Ill	CA	X																	
310.3 – 310.3.6	CA	X																	
313	CA	X																	
313.1	CA	X																	

The ◆ designation indicates that the Office of the State Fire Marshal's adoption of this chapter or individual sections is applicable to structures subject to HCD 1 and/or HCD 2 or DSA-SS.

CHAPTER 3

USE AND OCCUPANCY CLASSIFICATION

SECTION 301 GENERAL

301.1 Scope. The provisions of this chapter shall control the classification of all buildings and structures as to use and occupancy.

SECTION 302 CLASSIFICATION

302.1 General. Structures or portions of structures shall be classified with respect to occupancy in one or more of the groups listed below. A room or space that is intended to be occupied at different times for different purposes shall comply with all of the requirements that are applicable to each of the purposes for which the room or space will be occupied. Structures with multiple occupancies or uses shall comply with Section 508. Where a structure is proposed for a purpose that is not specifically provided for in this code, such structure shall be classified in the group that the occupancy most nearly resembles, according to the fire safety and relative hazard involved.

1. Assembly (see Section 303): Groups A-1, A-2, A-3, A-4 and A-5
2. Business (see Section 304): Group B
3. Educational (see Section 305): Group E
4. Factory and Industrial (see Section 306): Groups F-1 and F-2
5. High Hazard (see Section 307): Groups H-1, H-2, H-3, H-4 and H-5
6. Institutional (see Section 308): Groups I-1, I-2, I-3 and I-4
7. *Laboratory (see Section 202): Group B, unless classified as Group L (see Section 443) or Group H (Section 307).*
8. Mercantile (see Section 309): Group M
9. *[SFM] Organized Camps (see Section 440) Group C*
10. *Research Laboratories (see Section 443) Group L*
11. Residential (see Section 310): Groups R-1, R-2, R-3, R-3.1 and R-4
12. Storage (see Section 311): Groups S-1 and S-2
13. Utility and Miscellaneous (see Section 312): Group U

[SFM] Existing buildings housing existing protective social care homes or facilities established prior to 1972 (see Section 3413).

302.1.1 Reserved

302.1.2 Reserved

302.1.3 *Pharmacies; veterinary facilities; barbering, cosmetology, or electrolysis establishments; and acupuncture offices. See Chapter 12.*

SECTION 303 ASSEMBLY GROUP A

303.1 Assembly Group A. Assembly Group A occupancy includes, among others, the use of a building or structure, or a portion thereof, for the gathering of persons for purposes such as civic, social or religious functions; recreation, food or drink consumption; or awaiting transportation *or motion picture and television production studio sound stages, approved production facilities and production locations.*

Exceptions:

1. A building or tenant space used for assembly purposes with an occupant load of less than 50 persons shall be classified as a Group B occupancy.
2. A room or space used for assembly purposes with an occupant load of less than 50 persons and accessory to another occupancy shall be classified as a Group B occupancy or as part of that occupancy.
3. A room or space used for assembly purposes that is less than 750 square feet (70 m²) in area and is accessory to another occupancy shall be classified as a Group B occupancy or as part of that occupancy.

Assembly occupancies shall include the following:

A-1 Assembly uses, usually with fixed seating, intended for the production and viewing of the performing arts or motion picture including, but not limited to:

Motion picture and television production studio sound stages, approved production facilities and production locations (with live audiences).

Motion picture theaters

Symphony and concert halls

Television and radio studios admitting an audience

Theaters

A-2 Assembly uses intended for food and/or drink consumption including, but not limited to:

Banquet halls

Night clubs

Restaurants

Taverns and bars

A-3 Assembly uses intended for worship, recreation or amusement and other assembly uses not classified elsewhere in Group A including, but not limited to:

Amusement arcades

Art galleries

Bowling alleys

Places of religious worship

Community halls

Courtrooms

Dance halls (not including food or drink consumption)

Exhibition halls

Funeral parlors

Gymnasiums (without spectator seating)

Indoor swimming pools (without spectator seating)
 Indoor tennis courts (without spectator seating)
 Lecture halls
 Libraries
 Museums
 Waiting areas in transportation terminals
 Pool and billiard parlors

A-4 Assembly uses intended for viewing of indoor sporting events and activities with spectator seating including, but not limited to:

Arenas
 Skating rinks
 Swimming pools
 Tennis courts

A-5 Assembly uses intended for participation in or viewing outdoor activities including, but not limited to:

Amusement park structures
 Bleachers
 Grandstands
 Stadiums

303.2 Fixed guideway transit systems. [SFM] Fixed guideway transit system buildings shall conform to the requirements of this code for their occupancy classification in addition to the provisions set forth in Section 433.

303.3 Subterranean spaces for winery facilities in natural or manmade caves. [SFM] For fire and life safety requirements, see Section 436.

SECTION 304 BUSINESS GROUP B

304.1 Business Group B. Business Group B occupancy includes, among others, the use of a building or structure, or a portion thereof, for office, professional or service-type transactions, including storage of records and accounts. Business occupancies shall include, but not be limited to, the following:

Airport traffic control towers
 Animal hospitals, kennels and pounds
 Banks
 Barber and beauty shops
 Car wash
 Civic administration
 Clinic-outpatient [SFM] (not classified as Group I-2.1)
 Dry cleaning and laundries: pick-up and delivery stations and self-service
 Educational occupancies for students above the 12th grade
 Electronic data processing
 Laboratories: testing, research and [SFM] instruction
 Motor vehicle showrooms
 Post offices
 Print shops
 Professional services (architects, attorneys, dentists, physicians, engineers, etc.)
 Radio and television stations
 Telephone exchanges

Training and skill development not within a school or academic program

SECTION 305 EDUCATIONAL GROUP E

305.1 Educational Group E. Educational Group E occupancy includes, among others, the use of a building or structure, or a portion thereof, by more than six persons at any one time for educational purposes through the 12th grade. Religious educational rooms and religious auditoriums, which are accessory to places of religious worship in accordance with Section 508.3.1 and have occupant loads of less than 100, shall be classified as A-3 occupancies.

Exception: [SFM] A residence used as a home school for the children who normally reside at the residence. Such residences shall remain classified as Group R-2 or Group R-3 occupancies.

305.2 Day care. The use of a building or structure, or portion thereof, for educational, supervision or personal care services for more than six children older than 2½ years of age, shall be classified as a Group E occupancy.

Exception: [SFM] A day-care facility not otherwise classified as an R-3 occupancy, where occupants are not capable of responding to an emergency situation without physical assistance from the staff, shall be classified as Group I-4.

SECTION 306 FACTORY GROUP F

306.1 Factory Industrial Group F. Factory Industrial Group F occupancy includes, among others, the use of a building or structure, or a portion thereof, for assembling, disassembling, fabricating, finishing, manufacturing, packaging, repair or processing operations that are not classified as a Group H hazardous or Group S storage occupancy.

306.2 Factory Industrial F-1 Moderate-hazard Occupancy. Factory industrial uses which are not classified as Factory Industrial F-2 Low Hazard shall be classified as F-1 Moderate Hazard and shall include, but not be limited to, the following:

Aircraft
 Appliances
 Athletic equipment
 Automobiles and other motor vehicles
 Bakeries
 Beverages; over 12-percent alcohol content
 Bicycles
 Boats
 Brooms or brushes
 Business machines
 Cameras and photo equipment
 Canvas or similar fabric
 Carpets and rugs (includes cleaning)
 Clothing
 Construction and agricultural machinery
 Disinfectants

[F] TABLE 307.1(1) MAXIMUM ALLOWABLE QUANTITY PER CONTROL AREA OF HAZARDOUS MATERIALS POSING A PHYSICAL HAZARD^{a, j, m, n, p}

MATERIAL	CLASS	GROUP WHEN THE MAXIMUM ALLOWABLE QUANTITY IS EXCEEDED	STORAGE ^b			USE-CLOSED SYSTEMS ^b			USE-OPEN SYSTEMS ^b		
			Solid pounds (cubic feet)	Liquid gallons (pounds)	Gas (cubic feet at NTP)	Solid pounds (cubic feet)	Liquid gallons (pounds)	Gas (cubic feet at NTP)	Solid pounds (cubic feet)	Liquid gallons (pounds)	Liquid gallons (pounds)
Combustible liquid ^{c, i}	II	H-2 or H-3	N/A	120 ^{d, e}	N/A	N/A	N/A	120 ^d	30 ^d	30 ^d	30 ^d
	IIIA IIIB	H-2 or H-3 N/A	N/A	330 ^{d, e} 13,200 ^{e, f}	N/A	N/A	N/A	330 ^d 13,200 ^f	80 ^d 3,300 ^f	N/A	80 ^d 3,300 ^f
Combustible fiber	Loose baled ^o	H-3	(100) (1,000)	N/A	N/A	N/A	(100) (1,000)	N/A	(20) (200)	N/A	N/A
Consumer fireworks (Class C, Common)	1.4G	H-3	125 ^{d, e, 1}	N/A	N/A	N/A	N/A	N/A	N/A	N/A	N/A
Cryogenics flammable	N/A	H-2	N/A	45 ^d	N/A	N/A	N/A	45 ^d	N/A	N/A	10 ^d
	N/A	H-3	N/A	45 ^d	N/A	N/A	N/A	45 ^d	N/A	N/A	10 ^d
Explosives	Division 1.1	H-1	1 ^{e, g}	(1) ^{e, g}	N/A	N/A	0.25 ^g	(0.25) ^g	0.25 ^g	(0.25) ^g	(0.25) ^g
	Division 1.2	H-1	1 ^{e, g}	(1) ^{e, g}	N/A	N/A	0.25 ^g	(0.25) ^g	0.25 ^g	(0.25) ^g	(0.25) ^g
	Division 1.3	H-1 or 2	5 ^{e, g}	(5) ^{e, g}	N/A	N/A	1 ^g	(1) ^g	1 ^g	(1) ^g	(1) ^g
	Division 1.4	H-3	50 ^{e, g}	(50) ^{e, g}	N/A	N/A	50 ^g	(50) ^g	N/A	N/A	N/A
	Division 1.4G	H-3	125 ^{d, e, 1}	N/A	N/A	N/A	N/A	N/A	N/A	N/A	N/A
	Division 1.5 Division 1.6	H-1 H-1	1 ^{e, g} 1 ^{d, e, g}	(1) ^{e, g} N/A	N/A	N/A	0.25 ^g N/A	(0.25) ^g N/A	0.25 ^g N/A	0.25 ^g N/A	(0.25) ^g N/A
Flammable gas	Gaseous liquefied	H-2	N/A	N/A	1,000 ^{d, e} N/A	N/A	N/A	N/A	1,000 ^{d, e} N/A	N/A	N/A
Flammable liquid ^c	IA 1B and 1C	H-2 or H-3	N/A	30 ^{d, e} 120 ^{d, e}	N/A	N/A	N/A	30 ^d 120 ^d	N/A	N/A	10 ^d 30 ^d
Combination flammable liquid (IA, 1B, 1C)	N/A	H-2 or H-3	N/A	120 ^{d, e, h}	N/A	N/A	N/A	120 ^{d, h}	N/A	N/A	30 ^{d, h}
Flammable solid	N/A	H-3	125 ^{d, e}	N/A	N/A	N/A	125 ^d	N/A	25 ^d	N/A	N/A
Organic peroxide	UD	H-1	1 ^{e, g}	(1) ^{e, g}	N/A	N/A	0.25 ^g	(0.25) ^g	0.25 ^g	(0.25) ^g	(0.25) ^g
	I	H-2	5 ^{d, e}	(5) ^{d, e}	N/A	N/A	1 ^d	(1) ^d	1 ^d	(1) ^d	(1) ^d
	II	H-3	50 ^{d, e}	(50) ^{d, e}	N/A	N/A	50 ^d	(50) ^d	10 ^d	(10) ^d	(10) ^d
	III	H-3	125 ^{d, e}	(125) ^{d, e}	N/A	N/A	125 ^d	(125) ^d	25 ^d	(25) ^d	(25) ^d
	IV V	N/A N/A	NL NL	NL NL	N/A N/A	N/A N/A	NL NL	NL NL	NL NL	NL NL	NL NL
Oxidizer	4	H-1	1 ^{e, g}	(1) ^{e, g}	N/A	N/A	0.25 ^g	(0.25) ^g	0.25 ^g	(0.25) ^g	(0.25) ^g
	3 ^k	H-2 or H-3	10 ^{d, e}	(10) ^{d, e}	N/A	N/A	2 ^d	(2) ^d	2 ^d	(2) ^d	(2) ^d
	2	H-3	250 ^{d, e}	(250) ^{d, e}	N/A	N/A	250 ^d	(250) ^d	50 ^d	(50) ^d	(50) ^d
Oxidizing gas	1	N/A	4,000 ^{e, f}	(4,000) ^{e, f}	N/A	N/A	4,000 ^f	(4,000) ^f	1,000 ^f	(1,000) ^f	(1,000) ^f
	Gaseous liquefied	H-3	N/A	N/A	1,500 ^{d, e} N/A	N/A	N/A	N/A	1,500 ^{d, e} N/A	N/A	N/A

(continued)

[F] TABLE 307.1(1)—continued
 MAXIMUM ALLOWABLE QUANTITY PER CONTROL AREA OF HAZARDOUS MATERIALS POSING A PHYSICAL HAZARD^{a, j, m, n, p}

MATERIAL	CLASS	GROUP WHEN THE MAXIMUM ALLOWABLE QUANTITY IS EXCEEDED	STORAGE ^b			USE-CLOSED SYSTEMS ^b			USE-OPEN SYSTEMS ^b		
			Solid pounds (cubic feet)	Liquid gallons (pounds)	Gas (cubic feet at NTP)	Solid pounds (cubic feet)	Liquid gallons (pounds)	Gas (cubic feet at NTP)	Solid pounds (cubic feet)	Liquid gallons (pounds)	Liquid gallons (pounds)
Pyrophoric material	N/A	H-2	4 ^{c, g}	(4) ^{c, g}	50 ^{c, g}	1 ^g	1 ^g	10 ^{c, g}	0	0	0
Unstable (reactive)	4	H-1	1 ^{c, g}	(1) ^{c, g}	10 ^{d, g}	0.25 ^g	(0.25) ^g	2 ^{c, g}	0.25 ^g	(0.25) ^g	(0.25) ^g
	3	H-1 or H-2	5 ^{d, e}	(5) ^{d, e}	50 ^{d, e}	1 ^d	(1)	10 ^{d, e}	1 ^d	(1) ^d	(1) ^d
	2	H-3	50 ^{d, e}	(50) ^{d, e}	250 ^{d, e}	50 ^d	(50) ^d	250 ^{d, e}	10 ^d	(10) ^d	(10) ^d
	1	N/A	NL	NL	N/L	NL	N/L	NL	NL	NL	NL
Water reactive	3	H-2	5 ^{d, e}	(5) ^{d, e}	N/A	5 ^d	(5) ^d	N/A	1 ^d	(1) ^d	(1) ^d
	2	H-3	50 ^{d, e}	(50) ^{d, e}	N/A	50 ^d	(50) ^d	N/A	10 ^d	(10) ^d	(10) ^d
	1	N/A	NL	NL	N/A	NL	NL	N/A	NL	NL	NL

For SI: 1 cubic foot = 0.023 m³, 1 pound = 0.454 kg, 1 gallon = 3.785 L.

NL = Not Limited; N/A = Not Applicable; UD = Unclassified Detonable

a. For use of control areas, see Section 414.2.

b. The aggregate quantity in use and storage shall not exceed the quantity listed for storage.

c. The quantities of alcoholic beverages in retail and wholesale sales occupancies shall not be limited providing the liquids are packaged in individual containers not exceeding 1.3 gallons. In retail and wholesale sales occupancies, the quantities of medicines, foodstuffs, consumer or industrial products, and cosmetics containing not more than 50 percent by volume of water-miscible liquids with the remainder of the solutions not being flammable, shall not be limited, provided that such materials are packaged in individual containers not exceeding 1.3 gallons.

d. */SFM/ In other than Group L occupancies*, maximum allowable quantities shall be increased 100 percent in buildings equipped throughout with an automatic sprinkler system in accordance with Section 903.3.1.1. Where Note e also applies, the increase for both notes shall be applied cumulatively.

e. Maximum allowable quantities shall be increased 100 percent when stored in approved storage cabinets, day boxes, gas cabinets, exhausted enclosures or safety cans. Where Note d also applies, the increase for both notes shall be applied cumulatively.

f. The permitted quantities shall not be limited in a building equipped throughout with an automatic sprinkler system in accordance with Section 903.3.1.1.

g. Permitted only in buildings equipped throughout with an automatic sprinkler system in accordance with Section 903.3.1.1.

h. Containing not more than the maximum allowable quantity per control area of Class IA, IB or IC flammable liquids.

i. Inside a building, the maximum capacity of a combustible liquid storage system that is connected to a fuel-oil piping system shall be 660 gallons provided such system complies with the *California Fire Code*.

j. Quantities in parenthesis indicate quantity units in parenthesis at the head of each column.

k. A maximum quantity of 200 pounds of solid or 20 gallons of liquid Class 3 oxidizers is allowed when such materials are necessary for maintenance purposes, operation or sanitation of equipment. Storage containers and the manner of storage shall be approved.

l. Net weight of the pyrotechnic composition of the fireworks. Where the net weight of the pyrotechnic composition of the fireworks is not known, 25 percent of the gross weight of the fireworks, including packaging, shall be used.

m. For gallons of liquids, divide the amount in pounds by 10 in accordance with Section 2703.1.2 of the *California Fire Code*.

n. For storage and display quantities in Group M and storage quantities in Group S occupancies complying with Section 414.2.5, see Tables 414.2.5(1) and 414.2.5(2).

o. Densely packed baled cotton that complies with the packing requirements of ISO 8115 shall not be included in this material class.

p. The following shall not be included in determining the maximum allowable quantities:

1. Liquid or gaseous fuel in fuel tanks on vehicles.
2. Liquid or gaseous fuel in fuel tanks on motorized equipment operated in accordance with this code.
3. Gaseous fuels in piping systems and fixed appliances regulated by the *California Mechanical Code*.
4. Liquid fuels in piping systems and fixed appliances regulated by the *California Mechanical Code*.

[F] TABLE 307.1(2)
 MAXIMUM ALLOWABLE QUANTITY PER CONTROL AREA OF HAZARDOUS MATERIAL POSING A HEALTH HAZARD^{a, b, c, j}

MATERIAL	STORAGE ^d			USE-CLOSED SYSTEMS ^d			USE-OPEN SYSTEMS ^d	
	Solid pounds ^{e, f}	Liquid gallons (pounds) ^{e, f}	Gas (cubic feet at NTP) ^e	Solid pounds ^e	Liquid gallons (pounds) ^e	Gas (cubic feet at NTP) ^e	Solid pounds ^e	Liquid gallons (pounds) ^e
Corrosive	5,000	500	810 ^{f, g}	5,000	500	810 ^{f, g}	1,000	100
Highly toxic	10	(10) ⁱ	20 ^h	10	(10) ⁱ	20 ^h	3	(3) ⁱ
Toxic	500	(500) ⁱ	810 ^f	500	(500) ⁱ	810 ^f	125	(125) ⁱ

For SI: 1 cubic foot = 0.028 m³, 1 pound = 0.454 kg, 1 gallon = 3.785 L.

- a. For use of control areas, see Section 414.2.
- b. In retail and wholesale sales occupancies, the quantities of medicines, foodstuffs, consumer or industrial products, and cosmetics, containing not more than 50 percent by volume of water-miscible liquids and with the remainder of the solutions not being flammable, shall not be limited, provided that such materials are packaged in individual containers not exceeding 1.3 gallons.
- c. For storage and display quantities in Group M and storage quantities in Group S occupancies complying with Section 414.2.4, see Table 414.2.4(1).
- d. The aggregate quantity in use and storage shall not exceed the quantity listed for storage.
- e. [SFM] In other than Group L occupancies, maximum allowable quantities shall be increased 100 percent in buildings equipped throughout with an approved automatic sprinkler system in accordance with Section 903.3.1.1. Where Note f also applies, the increase for both notes shall be applied accumulatively.
- f. Quantities shall be increased 100 percent when stored in approved storage cabinets, gas cabinets or exhausted enclosures as specified in the *California Fire Code*. Where Note e also applies, the increase for both notes shall be applied accumulatively.
- g. A single cylinder containing 150 pounds or less of anhydrous ammonia in a single control area in a nonsprinklered building shall be considered a maximum allowable quantity. Two cylinders, each containing 150 pounds or less in a single control area, shall be considered a maximum allowable quantity provided the building is equipped throughout with an automatic sprinkler system in accordance with Section 903.3.1.1.
- h. Allowed only when stored in approved exhausted gas cabinets or exhausted enclosures as specified in the *California Fire Code*.
- i. Quantities in parenthesis indicate quantity units in parenthesis at the head of each column.
- j. For gallons of liquids, divide the amount in pounds by 10 in accordance with Section 2703.1.2 of the *California Fire Code*.

COMPRESSED GAS. A material, or mixture of materials which:

1. Is a gas at 68°F (20°C) or less at 14.7 pounds per square inch atmosphere (psia) (101 kPa) or pressure; and
2. Has a boiling point of 68°F (20°C) or less at 14.7 psia (101 kPa) which is either liquefied, nonliquefied or in solution, except those gases which have no other health- or physical-hazard properties are not considered to be compressed until the pressure in the packaging exceeds 41 psia (282 kPa) at 68°F (20°C).

The states of a compressed gas are categorized as follows:

1. Nonliquefied compressed gases are gases, other than those in solution, which are in a packaging under the charged pressure and are entirely gaseous at a temperature of 68°F (20°C).
2. Liquefied compressed gases are gases that, in a packaging under the charged pressure, are partially liquid at a temperature of 68°F (20°C).
3. Compressed gases in solution are nonliquefied gases that are dissolved in a solvent.
4. Compressed gas mixtures consist of a mixture of two or more compressed gases contained in a packaging, the hazard properties of which are represented by the properties of the mixture as a whole.

CONTROL AREA. Spaces within a building where quantities of hazardous materials not exceeding the maximum allowable quantities per control area are stored, dispensed, used or handled. See also the definition of “Outdoor control area” in the *California Fire Code*.

CORROSIVE. A chemical that causes visible destruction of, or irreversible alterations in, living tissue by chemical action at the point of contact. A chemical shall be considered corrosive

if, when tested on the intact skin of albino rabbits by the method described in DOTn 49 CFR, Part 173.137, such a chemical destroys or changes irreversibly the structure of the tissue at the point of contact following an exposure period of 4 hours. This term does not refer to action on inanimate surfaces.

CRYOGENIC FLUID. A liquid having a boiling point lower than -150°F (-101°C) at 14.7 pounds per square inch atmosphere (psia) (an absolute pressure of 101 kPa).

DAY BOX. A portable magazine designed to hold explosive materials constructed in accordance with the requirements for a Type 3 magazine as defined and classified in Chapter 33 of the *California Fire Code*.

DEFLAGRATION. An exothermic reaction, such as the extremely rapid oxidation of a flammable dust or vapor in air, in which the reaction progresses through the unburned material at a rate less than the velocity of sound. A deflagration can have an explosive effect.

DETACHED BUILDING. A separate single-story building, without a basement or crawl space, used for the storage or use of hazardous materials and located an approved distance from all structures.

DETONATION. An exothermic reaction characterized by the presence of a shock wave in the material which establishes and maintains the reaction. The reaction zone progresses through the material at a rate greater than the velocity of sound. The principal heating mechanism is one of shock compression. Detonations have an explosive effect.

DISPENSING. The pouring or transferring of any material from a container, tank or similar vessel, whereby vapors, dusts, fumes, mists or gases are liberated to the atmosphere.

EXPLOSIVE. Any chemical compound, mixture or device, the primary or common purpose of which is to function by

explosion. The term includes, but is not limited to, dynamite, black powder, pellet powder, initiating explosives, detonators, safety fuses, squibs, detonating cord, igniter cord, igniters and display fireworks, 1.3G (Class B, Special).

The term “explosive” includes any material determined to be within the scope of USC Title 18: Chapter 40 and also includes any material classified as an explosive other than consumer fireworks, 1.4G (Class C, Common) by the hazardous materials regulations of DOTn 49 CFR.

High explosive. Explosive material, such as dynamite, which can be caused to detonate by means of a No. 8 test blasting cap when unconfined.

Low explosive. Explosive material that will burn or deflagrate when ignited. It is characterized by a rate of reaction that is less than the speed of sound. Examples of low explosives include, but are not limited to, black powder; safety fuse; igniters; igniter cord; fuse lighters; fireworks, 1.3G (Class B, Special) and propellants, 1.3C.

Mass-detonating explosives. Division 1.1, 1.2 and 1.5 explosives alone or in combination, or loaded into various types of ammunition or containers, most of which can be expected to explode virtually instantaneously when a small portion is subjected to fire, severe concussion, impact, the impulse of an initiating agent or the effect of a considerable discharge of energy from without. Materials that react in this manner represent a mass explosion hazard. Such an explosive will normally cause severe structural damage to adjacent objects. Explosive propagation could occur immediately to other items of ammunition and explosives stored sufficiently close to and not adequately protected from the initially exploding pile with a time interval short enough so that two or more quantities must be considered as one for quantity-distance purposes.

UN/DOTn Class 1 explosives. The former classification system used by DOTn included the terms “high” and “low” explosives as defined herein. The following terms further define explosives under the current system applied by DOTn for all explosive materials defined as hazard Class 1 materials. Compatibility group letters are used in concert with the division to specify further limitations on each division noted (i.e., the letter G identifies the material as a pyrotechnic substance or article containing a pyrotechnic substance and similar materials).

Division 1.1. Explosives that have a mass explosion hazard. A mass explosion is one which affects almost the entire load instantaneously.

Division 1.2. Explosives that have a projection hazard but not a mass explosion hazard.

Division 1.3. Explosives that have a fire hazard and either a minor blast hazard or a minor projection hazard or both, but not a mass explosion hazard.

Division 1.4. Explosives that pose a minor explosion hazard. The explosive effects are largely confined to the package and no projection of fragments of appreciable size or range is to be expected. An external fire must not cause virtually instantaneous explosion of almost the entire contents of the package.

Division 1.5. Very insensitive explosives. This division is comprised of substances that have a mass explosion hazard, but that are so insensitive there is very little probability of initiation or of transition from burning to detonation under normal conditions of transport.

Division 1.6. Extremely insensitive articles which do not have a mass explosion hazard. This division is comprised of articles that contain only extremely insensitive detonating substances and which demonstrate a negligible probability of accidental initiation or propagation.

FIREWORKS. Any composition or device for the purpose of producing a visible or audible effect for entertainment purposes by combustion, deflagration or detonation that meets the definition of 1.4G fireworks or 1.3G fireworks as set forth herein.

FIREWORKS, 1.3G. (Formerly Class B, Special Fireworks.) Large fireworks devices, which are explosive materials, intended for use in fireworks displays and designed to produce audible or visible effects by combustion, deflagration or detonation. Such 1.3G fireworks include, but are not limited to, firecrackers containing more than 130 milligrams (2 grains) of explosive composition, aerial shells containing more than 40 grams of pyrotechnic composition, and other display pieces which exceed the limits for classification as 1.4G fireworks. Such 1.3G fireworks are also described as fireworks, UN0335 by the DOTn.

FIREWORKS, 1.4G. (Formerly Class C, Common Fireworks.) Small fireworks devices containing restricted amounts of pyrotechnic composition designed primarily to produce visible or audible effects by combustion. Such 1.4G fireworks which comply with the construction, chemical composition and labeling regulations of the DOTn for fireworks, UN0336, and the U.S. Consumer Product Safety Commission (CPSC) as set forth in CPSC 16 CFR: Parts 1500 and 1507, are not explosive materials for the purpose of this code.

FLAMMABLE GAS. A material that is a gas at 68°F (20°C) or less at 14.7 pounds per square inch atmosphere (psia) (101 kPa) of pressure [a material that has a boiling point of 68°F (20°C) or less at 14.7 psia (101 kPa)] which:

1. Is ignitable at 14.7 psia (101 kPa) when in a mixture of 13 percent or less by volume with air; or
2. Has a flammable range at 14.7 psia (101 kPa) with air of at least 12 percent, regardless of the lower limit.

The limits specified shall be determined at 14.7 psi (101 kPa) of pressure and a temperature of 68°F (20°C) in accordance with ASTM E 681.

FLAMMABLE LIQUEFIED GAS. A liquefied compressed gas which, under a charged pressure, is partially liquid at a temperature of 68°F (20°C) and which is flammable.

FLAMMABLE LIQUID. A liquid having a closed cup flash point below 100°F (38°C). Flammable liquids are further categorized into a group known as Class I liquids. The Class I category is subdivided as follows:

Class IA. Liquids having a flash point below 73°F (23°C) and a boiling point below 100°F (38°C).

local standards applicable to Group R, Division 3 occupancies. [See Health and Safety Code, Section 13143 (b).]

DORMITORY. A space in a building where group sleeping accommodations are provided in one room, or in a series of closely associated rooms, for persons not members of the same family group, under joint occupancy and single management, as in college dormitories or fraternity houses.

FULL-TIME CARE [B] [SFM] shall mean the establishment and routine care of persons on an hourly, daily, weekly, monthly, yearly or permanent basis, whether for 24 hours per day or less, and where sleeping accommodations are provided.

INFANT, [B] [SFM] for the purpose of these regulations, shall mean any child who because of age only, is unable to walk and requires the aid of another person to evacuate the building. In no case shall the term "infant" mean a child beyond two years of age.

MENTALLY RETARDED PERSONS, PROFOUNDLY OR SEVERELY [B] [SFM] shall mean any retarded person who is unable to evacuate a building unassisted during emergency conditions.

Note: The determination as to such incapacity shall be made by the Director of the State Department of Public Health or his or her designated representative pursuant to Health and Safety Code Section 13131.3.

NONAMBULATORY PERSONS [B] [SFM] are persons unable to leave a building unassisted under emergency conditions. It includes, but is not limited to, persons who depend on mechanical aids such as crutches, walkers and wheelchairs and any person who is unable to physically and mentally respond to a sensory signal approved by the State Fire Marshal or an oral instruction relating to fire danger.

The determination of ambulatory or nonambulatory status of persons with developmental disabilities shall be made by the Director of Social Services or his or her designated representative, in consultation with the director of Developmental Services or his or her designated representative. The determination of ambulatory or nonambulatory status of all other disabled persons placed after January 1, 1984, who are not developmentally disabled shall be made by the Director of Social Services or his or her designated representative.

RESIDENTIAL CARE FACILITY FOR THE CHRONICALLY ILL (RCF/CI) [SFM] as termed, means a housing arrangement with a maximum capacity of 25 residents that provides a range of services to residents who have chronic, life-threatening illnesses.

RESIDENTIAL CARE FACILITY FOR THE ELDERLY (RCFE) [SFM] as defined in Health and Safety Code Section 1569.2, shall mean a facility with a housing arrangement chosen voluntarily by persons 60 years of age or over, or their authorized representative, where varying levels and intensities of care and supervision, protective supervision or personal care are provided, based on their varying needs, as determined in order to be admitted and to remain in the facility. Persons under 60 years of age with compatible needs, as determined by

the Department of Social Services in regulations, may be allowed to be admitted or retained in a residential care facility for the elderly.

Pursuant to Health and Safety Code Section 13133, regulations of the state fire marshal pertaining to Group R, Division 2 occupancies classified as Residential Facilities (RF) and Residential Care Facilities for the Elderly (RCFE) shall apply uniformly throughout the state and no city, county, city and county, including a charter city or charter county, or fire protection district shall adopt or enforce any ordinance or local rule or regulation relating to fire and panic safety which is inconsistent with these regulations. A city, county, city and county, including a charter city or charter county may pursuant to Health and Safety Code Section 13143.5, or a fire protection district may pursuant to Health and Safety Code Section 13869.7, adopt standards more stringent than those adopted by the state fire marshal that are reasonably necessary to accommodate local climate, geological, or topographical conditions relating to roof coverings for Residential-Care Facilities for the Elderly.

RESIDENTIAL FACILITY (RF) [SFM] as defined in Section 1502 of the Health and Safety Code, shall mean any family home, group care facility, or similar facility determined by the director of Social Services, for 24-hour nonmedical care of persons in need of personal services, supervision, or assistance essential for sustaining the activities of daily living or for the protection of the individual. Such facilities include small family homes and social rehabilitation facilities.

Pursuant to Health and Safety Code Section 13133, regulations of the State Fire Marshal pertaining to Group R Occupancies classified as Residential Facilities (RF) and Residential Care Facilities for the Elderly (RCFE) shall apply uniformly throughout the state and no city, county, city and county, including a charter city or charter county, or fire protection district shall adopt or enforce any ordinance or local rule or regulation relating to fire and panic safety which is inconsistent with these regulations. A city, county, city and county, including a charter city or charter county may pursuant to Health and Safety Code Section 13143.5, or a fire protection district may pursuant to Health and Safety Code Section 13869.7, adopt standards more stringent than those adopted by the state fire marshal that are reasonably necessary to accommodate local climate, geological, or topographical conditions relating to roof coverings for Residential Care Facilities for the Elderly.

TERMINALLY ILL [SFM] as termed for an individual, means the individual has a life expectancy of six months or less as stated in writing by his or her attending physician and surgeon.

TRANSIENT. Occupancy of a dwelling unit or sleeping unit for not more than 30 days.

310.3 Large-family day care homes. See Section 445.

SECTION 311 STORAGE GROUP S

311.1 Storage Group S. Storage Group S occupancy includes, among others, the use of a building or structure, or a portion thereof, for storage that is not classified as a hazardous occupancy.

311.2 Moderate-hazard storage, Group S-1. Buildings occupied for storage uses that are not classified as Group S-2, including, but not limited to, storage of the following:

- Aerosols, Levels 2 and 3
- Aircraft repair hangar
- Bags: cloth, burlap and paper
- Bamboos and rattan
- Baskets
- Belting: canvas and leather
- Books and paper in rolls or packs
- Boots and shoes
- Buttons, including cloth covered, pearl or bone
- Cardboard and cardboard boxes
- Clothing, woolen wearing apparel
- Cordage
- Dry boat storage (indoor)
- Furniture
- Furs
- Glues, mucilage, pastes and size
- Grains
- Horns and combs, other than celluloid
- Leather
- Linoleum
- Lumber
- Motor vehicle repair garages complying with the maximum allowable quantities of hazardous materials listed in Table 307.1(1) (see Section 406.6)
- Photo engravings
- Resilient flooring
- Silks
- Soaps
- Sugar
- Tires, bulk storage of
- Tobacco, cigars, cigarettes and snuff
- Upholstery and mattresses
- Wax candles

311.3 Low-hazard storage, Group S-2. Includes, among others, buildings used for the storage of noncombustible materials such as products on wood pallets or in paper cartons with or without single thickness divisions; or in paper wrappings. Such products are permitted to have a negligible amount of plastic trim, such as knobs, handles or film wrapping. Storage uses shall include, but not be limited to, storage of the following:

- Aircraft hangar
- Asbestos
- Beverages up to and including 12-percent alcohol in metal, glass or ceramic containers
- Cement in bags
- Chalk and crayons
- Dairy products in nonwaxed coated paper containers

- Dry cell batteries
- Electrical coils
- Electrical motors
- Empty cans
- Food products
- Foods in noncombustible containers
- Fresh fruits and vegetables in nonplastic trays or containers
- Frozen foods
- Glass
- Glass bottles, empty or filled with noncombustible liquids
- Gypsum board
- Inert pigments
- Ivory
- Meats
- Metal cabinets
- Metal desks with plastic tops and trim
- Metal parts
- Metals
- Mirrors
- Oil-filled and other types of distribution transformers
- Parking garages, open or enclosed
- Porcelain and pottery
- Stoves
- Talc and soapstones
- Washers and dryers

SECTION 312 UTILITY AND MISCELLANEOUS GROUP U

312.1 General. Buildings and structures of an accessory character and miscellaneous structures not classified in any specific occupancy shall be constructed, equipped and maintained to conform to the requirements of this code commensurate with the fire and life hazard incidental to their occupancy. Group U shall include, but not be limited to, the following:

- Agricultural buildings
- Aircraft hangars, accessory to a one- or two-family residence (see Section 412.3)
- Barns
- Carports
- Fences more than 6 feet (1829 mm) high
- Grain silos, accessory to a residential occupancy
- Greenhouses
- Livestock shelters
- Private garages
- Retaining walls
- Sheds
- Stables
- Tanks
- Towers

SECTION 313 LABORATORIES GROUP L [SFM]

313.1 Laboratories Group L. [SFM] Group L occupancy includes the use of a building or structure, or a portion thereof, containing one or more laboratory suites as defined in Section 443.

(Pages 65 and 66 have been deleted. Text continues on page 67.)

**CALIFORNIA BUILDING CODE – MATRIX ADOPTION TABLE
CHAPTER 4 – SPECIAL DETAILED REQUIREMENTS BASED
ON USE AND OCCUPANCY**

Adopting Agency	BSC	SFM	HCD			DSA		OSHPD				CSA	DHS	AGR	DWR	CEC	CA	SL	SLC
			1	2	1/AC	AC	SS	1	2	3	4								
Adopt Entire Chapter	X						X ◆	X	X	X	X	X							
Adopt Entire Chapter as amended (amended sections listed below)		X	X ◆	X ◆															
Adopt only those sections that are listed below						X													
Chapter / Section	Codes																		
403.1	CA	X																	
403.1.1	CA	X																	
403.1.2	CA	X																	
403.2	CA	X																	
403.3.1	CA	X																	
403.9	CA	X																	
403.11	CA	X																	
403.11.1	CA	X																	
403.12	CA	X																	
403.13	CA	X																	
403.13.1	CA	X																	
403.13.2	CA	X																	
403.15	CA	X																	
404.5	CA	X																	
404.9	CA	X																	
405.1	CA	X																	
406.2.2	CA					X													
406.7 – 406.7.4	CA	X	◆	◆															
407.1	CA	X																	
407.2	CA	X																	
407.2.1	CA	X																	
407.2.2	CA	X																	
407.3	CA	X																	
407.3.1	CA	X																	
407.3.1.1	CA	X																	
407.3.3	CA	X																	
407.3.4	CA	X																	
407.4	CA	X																	
407.4.2	CA	X																	
407.5	CA	X																	
407.5.1	CA	X																	
407.6	CA	X																	
407.7	CA	X																	
408.1.1	CA	X																	
408.2	CA	X																	
408.3.1.1	CA	X																	
408.3.4	CA	X																	
408.3.4.1	CA	X																	
408.3.4.2	CA	X																	
408.3.4.3	CA	X																	

**CHAPTER 4 – SPECIAL DETAILED REQUIREMENTS
BASED ON USE AND OCCUPANCY (Continued)**

Adopting Agency		BSC	SFM	HCD			DSA		OSHPD				CSA	DHS	AGR	DWR	CEC	CA	SL	SLC
				1	2	1/AC	AC	SS	1	2	3	4								
Adopt Entire Chapter		X						X ◆												
Adopt Entire Chapter as amended (amended sections listed below)			X	X ◆	X ◆					X	X	X	X							
Adopt only those sections that are listed below							X													
Chapter / Section	Codes																			
408.3.4.3	CA		X																	
408.3.4.4	CA		X																	
408.3.6	CA		X																	
408.3.6.1	CA		X																	
408.3.6.2	CA		X																	
408.4	CA		X																	
408.4.3	CA		X																	
408.5	CA		X																	
408.6	CA		X																	
408.7	CA		X																	
408.7.1	CA		X																	
408.9 – 408.14	CA		X																	
409.3	IBC			X	X															
410.2 Platform & Stage	IBC						X													
412.1.6	CA						X													
414.1.1	CA		X																	
419.1	CA		X																	
419.4	CA			X																
419.4.1	CA			X																
419.4.2	CA			X																
419.4.3	CA			X																
419.4.4	CA			X																
419.5	CA		X																	
419.6	CA		X																	
425	CA		X																	
426	CX		X																	
430	CA		X																	
431	CA		X																	
432	CA		X																	
433	CA		X																	
434	CA		X																	

NEW HIGH-RISE BUILDING. A high-rise structure, the construction of which is commenced on or after July 1, 1974. For the purpose of this section, construction shall be deemed to have commenced when plans and specifications are more than 50 percent complete and have been presented to the local jurisdiction prior to July 1, 1974. Unless all provisions of this section have been met, the construction of such buildings shall commence on or before January 1, 1976.

[F] 403.2 Automatic sprinkler system. Buildings and structures shall be equipped throughout with an automatic sprinkler system in accordance with Section 903.3.1.1 and a secondary water supply where required by Section 903.3.5.2. A sprinkler water-flow alarm-initiating device and a control valve with a supervisory signal-initiating device shall be provided at the lateral connection to the riser for each floor.

Exception: An automatic sprinkler system shall not be required in spaces or areas of:

1. Open parking garages in accordance with Section 406.3.
2. Telecommunications equipment buildings used exclusively for telecommunications equipment, associated electrical power distribution equipment, batteries and standby engines, provided that those spaces or areas are equipped throughout with an automatic fire detection system in accordance with Section 907.2 and are separated from the remainder of the building by fire barriers consisting of not less than 1-hour fire-resistance-rated walls and 2-hour fire-resistance-rated floor/ceiling assemblies.

403.3 Reduction in fire-resistance rating. The fire-resistance-rating reductions listed in Sections 403.3.1 and 403.3.2 shall be allowed in buildings that have sprinkler control valves equipped with supervisory initiating devices and water-flow initiating devices for each floor.

403.3.1 Type of construction. The following reductions in the minimum construction type allowed in Table 601 shall be allowed as provided in Section 403.3:

1. For buildings not greater than 420 feet (128 m) in height, Type IA construction shall be allowed to be reduced to Type IB.

Exception: The required fire-resistance rating of the structural frame shall not be allowed to be reduced.

2. In other than Groups F-1, M and S-1, Type IB construction shall be allowed to be reduced to Type IIA.

Exception: The required fire-resistance rating of the structural frame shall not be allowed to be reduced.

3. The height and area limitations of the reduced construction type shall be allowed to be the same as for the original construction type.

403.3.2 Shaft enclosures. For buildings not greater than 420 feet (128 m) in height, the required fire-resistance rating of the fire barriers enclosing vertical shafts, other than exit enclosures and elevator hoistway enclosures, shall be

reduced to 1 hour where automatic sprinklers are installed within the shafts at the top and at alternate floor levels.

403.4 Emergency escape and rescue. Emergency escape and rescue openings required by Section 1026 are not required.

[F] 403.5 Automatic fire detection. Smoke detection shall be provided in accordance with Section 907.2.12.1.

[F] 403.6 Emergency voice/alarm communication systems. An emergency voice/alarm communication system shall be provided in accordance with Section 907.2.12.2.

[F] 403.7 Fire department communications system. A two-way fire department communications system shall be provided for fire department use in accordance with Section 907.2.12.3.

[F] 403.8 Fire command. A fire command center complying with Section 911 shall be provided in a location approved by the fire department.

403.9 Elevators. Elevator operation and installation shall be in accordance with Chapter 30.

Elevator lobbies shall be provided in accordance with Section 707.14.1.

[F] 403.10 Standby power. A standby power system complying with Section 2702 shall be provided for standby power loads specified in Section 403.10.2.

403.10.1 Special requirements for standby power systems. If the standby system is a generator set inside a building, the system shall be located in a separate room enclosed with 2-hour fire barriers constructed in accordance with Section 706 or horizontal assemblies constructed in accordance with Section 711, or both. System supervision with manual start and transfer features shall be provided at the fire command center.

[F] 403.10.2 Standby power loads. The following are classified as standby power loads:

1. Power and lighting for the fire command center required by Section 403.8; *and*
2. Ventilation and automatic fire detection equipment for smokeproof enclosures.

Standby power shall be provided for elevators in accordance with Sections 1007.4 and 3003.

[F] 403.11 Emergency power systems. An emergency power system complying with Section 2702 shall be provided for emergency power loads specified in Section 403.11.1.

[F] 403.11.1 Emergency power loads. The following are classified as emergency power loads:

1. Exit signs and means of egress illumination required by Chapter 10;
2. Elevator car lighting;
3. Emergency voice/alarm communications systems;
4. Automatic fire detection systems; *and*
5. Fire alarm systems; *and*
6. Fire pumps.

403.12 Stairway door operation. Stairway doors other than the exit discharge doors shall be permitted to be locked from stairway side. Stairway doors that are locked from the stairway side shall be capable of being unlocked simultaneously without unlatching upon a signal from the fire command center. *[SFM] Upon failure of electrical power to the locking mechanism the door shall unlock.*

403.12.1 Stairway communications system. A telephone or other two-way communications system connected to an approved constantly attended station shall be provided at not less than every fifth floor in each required stairway where the doors to the stairway are locked.

403.13 Smoke control.

403.13.1 Smoke control system. *High-rise buildings shall be provided with a passive or active smoke control system or combination thereof in accordance with Section 909.*

403.13.2 Smokeproof exit enclosures. *Every exit enclosure in high-rise buildings shall comply with Sections 909.20 and 1020.1.7. Every required stairway in Group I-2 Occupancies serving floors more than 75 feet (22 860 mm) above the lowest level of fire department vehicle access shall comply with Sections 909.20 and 1020.1.7.*

403.14 Seismic considerations. For seismic considerations, see Chapter 16.

403.15 Existing high-rise buildings. *For existing high-rise buildings, see Section 3412.*

SECTION 404 ATRIUMS

404.1 General. In other than Group H occupancies, and where permitted by Exception 5 in Section 707.2, the provisions of this section shall apply to buildings or structures containing vertical openings defined herein as "Atriums."

404.1.1 Definition. The following word and term shall, for the purposes of this chapter and as used elsewhere in this code, have the meaning shown herein.

ATRIUM. An opening connecting two or more stories other than enclosed stairways, elevators, hoistways, escalators, plumbing, electrical, air-conditioning or other equipment, which is closed at the top and not defined as a mall. Stories, as used in this definition, do not include balconies within assembly groups or mezzanines that comply with Section 505.

404.2 Use. The floor of the atrium shall not be used for other than low fire hazard uses and only approved materials and decorations in accordance with the *California Fire Code* shall be used in the atrium space.

Exception: The atrium floor area is permitted to be used for any approved use where the individual space is provided with an automatic sprinkler system in accordance with Section 903.3.1.1.

[F] 404.3 Automatic sprinkler protection. An approved automatic sprinkler system shall be installed throughout the entire building.

Exceptions:

1. That area of a building adjacent to or above the atrium need not be sprinklered, provided that portion of the building is separated from the atrium portion by not less than a 2-hour fire-resistance-rated fire barrier or horizontal assembly, or both.
2. Where the ceiling of the atrium is more than 55 feet (16 764 mm) above the floor, sprinkler protection at the ceiling of the atrium is not required.

404.4 Smoke control. A smoke control system shall be installed in accordance with Section 909.

Exception: Smoke control is not required for atriums that connect only two stories.

404.5 Enclosure of atriums. Atrium spaces shall be separated from adjacent spaces by a 1-hour fire barrier constructed in accordance with Section 706 or a horizontal assembly constructed in accordance with Section 711, or both.

Exceptions:

1. A glass wall forming a smoke partition where automatic sprinklers are spaced 6 feet (1829 mm) or less along both sides of the separation wall, or on the room side only if there is not a walkway on the atrium side, and between 4 inches and 12 inches (102 mm and 305 mm) away from the glass and designed so that the entire surface of the glass is wet upon activation of the sprinkler system without obstruction. The glass shall be installed in a gasketed frame so that the framing system deflects without breaking (loading) the glass before the sprinkler system operates.
2. A glass-block wall assembly in accordance with Section 2110 and having a $3/4$ -hour fire protection rating.
3. *[SFM] In other than Group I occupancies, the adjacent spaces of any three floors of the atrium shall not be required to be separated from the atrium where such spaces are included in the design of the smoke control system.*

[F] 404.6 Standby power. Equipment required to provide smoke control shall be connected to a standby power system in accordance with Section 909.11.

404.7 Interior finish. The interior finish of walls and ceilings of the atrium shall not be less than Class B with no reduction in class for sprinkler protection.

404.8 Travel distance. In other than the lowest level of the atrium, where the required means of egress is through the atrium space, the portion of exit access travel distance within the atrium space shall not exceed 200 feet (60 960 mm).

404.9 Group I occupancy means of egress. *[SFM] Required means of egress from sleeping rooms in Group I occupancies shall not pass through the atrium.*

SECTION 405 UNDERGROUND BUILDINGS

405.1 General. The provisions of this section apply to building spaces having a floor level used for human occupancy more

[F] 412.4.4 Storage. Storage of flammable liquids shall be in a liquid storage room.

[F] 412.4.5 Fire suppression. Aircraft paint hangars shall be provided with fire suppression as required by NFPA 409.

412.4.6 Ventilation. Aircraft paint hangars shall be provided with ventilation as required in the *California Mechanical Code*.

412.5 Heliports and helistops. Heliports and helistops shall be permitted to be erected on buildings or other locations where they are constructed in accordance with this section.

412.5.1 Definitions. The following words and terms shall, for the purposes of this chapter and as used elsewhere in this code, have the meanings shown herein.

HELIPORT. An area of land or water or a structural surface that is used, or intended for use, for the landing and taking off of helicopters, and any appurtenant areas that are used, or intended for use, for heliport buildings and other heliport facilities.

HELISTOP. The same as a "heliport," except that no fueling, defueling, maintenance, repairs or storage of helicopters is permitted.

412.5.2 Size. The landing area for helicopters less than 3,500 pounds (1588 kg) shall be a minimum of 20 feet (6096 mm) in length and width. The landing area shall be surrounded on all sides by a clear area having a minimum average width at roof level of 15 feet (4572 mm) but with no width less than 5 feet (1524 mm).

412.5.3 Design. Helicopter landing areas and the supports thereof on the roof of a building shall be noncombustible construction. Landing areas shall be designed to confine any flammable liquid spillage to the landing area itself and provisions shall be made to drain such spillage away from any exit or stairway serving the helicopter landing area or from a structure housing such exit or stairway. For structural design requirements, see Section 1605.5.

412.5.4 Means of egress. The means of egress from heliports and helistops shall comply with the provisions of Chapter 10. Landing areas located on buildings or structures shall have two or more means of egress. For landing areas less than 60 feet (18 288 mm) in length, or less than 2,000 square feet (186 m²) in area, the second means of egress may be a fire escape or ladder leading to the floor below.

412.5.5 Rooftop heliports and helistops. Rooftop heliports and helistops shall comply with NFPA 418.

SECTION 413 COMBUSTIBLE STORAGE

413.1 General. High-piled stock or rack storage in any occupancy group shall comply with the *California Fire Code*.

413.2 Attic, under-floor and concealed spaces. Attic, under-floor and concealed spaces used for storage of combustible materials shall be protected on the storage side as required for 1-hour fire-resistance-rated construction. Openings shall be protected by assemblies that are self-closing and are of

noncombustible construction or solid wood core not less than 1³/₄ inches (45 mm) in thickness.

Exceptions:

1. Areas protected by approved automatic sprinkler systems.
2. Group R-3 and U occupancies.

SECTION 414 HAZARDOUS MATERIALS

[F] 414.1 General. The provisions of this section shall apply to buildings and structures occupied for the manufacturing, processing, dispensing, use or storage of hazardous materials.

[F] 414.1.1 Other provisions. Buildings and structures with an occupancy in Group H shall also comply with the applicable provisions of Section 415 and the *California Fire Code*. For Group L occupancies see Section 443.

[F] 414.1.2 Materials. The safe design of hazardous material occupancies is material dependent. Individual material requirements are also found in Sections 307 and 415, and in the *California Mechanical Code* and the *California Fire Code*.

[F] 414.1.2.1 Aerosols. Level 2 and 3 aerosol products shall be stored and displayed in accordance with the *California Fire Code*. See Section 311.2 and the *California Fire Code* for occupancy group requirements.

[F] 414.1.3 Information required. Separate floor plans shall be submitted for buildings and structures with an occupancy in Group H, identifying the locations of anticipated contents and processes so as to reflect the nature of each occupied portion of every building and structure. A report identifying hazardous materials including, but not limited to, materials representing hazards that are classified in Group H to be stored or used, shall be submitted and the methods of protection from such hazards shall be indicated on the construction documents. The opinion and report shall be prepared by a qualified person, firm or corporation approved by the building official and shall be provided without charge to the enforcing agency.

[F] 414.2 Control areas. Control areas shall comply with Sections 414.2.1 through 414.2.5 and the *California Fire Code*.

414.2.1 Construction requirements. Control areas shall be separated from each other by fire barriers constructed in accordance with Section 706 or horizontal assemblies constructed in accordance with Section 711, or both.

[F] 414.2.2 Percentage of maximum allowable quantities. The percentage of maximum allowable quantities of hazardous materials per control area permitted at each floor level within a building shall be in accordance with Table 414.2.2.

[F] 414.2.3 Number. The maximum number of control areas within a building shall be in accordance with Table 414.2.2.

414.2.4 Fire-resistance-rating requirements. The required fire-resistance rating for fire barriers shall be in

SPECIAL DETAILED REQUIREMENTS BASED ON USE AND OCCUPANCY

accordance with Table 414.2.2. The floor construction of the control area and the construction supporting the floor of the control area shall have a minimum 2-hour fire-resistance rating.

Exception: The floor construction of the control area and the construction supporting the floor of the control area are allowed to be 1-hour fire-resistance rated in buildings of Type IIA, IIIA and VA construction, provided that both of the following conditions exist:

1. The building is equipped throughout with an automatic sprinkler system in accordance with Section 903.3.1.1, and
2. The building is three stories or less in height.

[F] 414.2.5 Hazardous material in Group M display and storage areas and in Group S storage areas. The aggregate quantity of nonflammable solid and nonflammable or noncombustible liquid hazardous materials permitted within a single control area of a Group M display and storage area, a Group S storage area or an outdoor control area is permitted to exceed the maximum allowable quantities per control area specified in Tables 307.1(1) and 307.1(2) without classifying the building or use as a Group H occupancy, provided that the materials are displayed and stored in accordance with the *California Fire Code* and quantities do not exceed the maximum allowable specified in Table 414.2.5(1).

In Group M occupancy wholesale and retail sales uses, indoor storage of flammable and combustible liquids shall not exceed the maximum allowable quantities per control area as indicated in Table 414.2.5(2), provided that the materials are displayed and stored in accordance with the *California Fire Code*.

The maximum quantity of aerosol products in Group M occupancy retail display areas, storage areas adjacent to retail display areas and retail storage areas shall be in accordance with the *California Fire Code*.

[F] 414.3 Ventilation. Rooms, areas or spaces of Group H in which explosive, corrosive, combustible, flammable or highly toxic dusts, mists, fumes, vapors or gases are or may be emitted

due to the processing, use, handling or storage of materials shall be mechanically ventilated as required by the *California Fire Code* and the *California Mechanical Code*.

Ducts conveying explosives or flammable vapors, fumes or dusts shall extend directly to the exterior of the building without entering other spaces. Exhaust ducts shall not extend into or through ducts and plenums.

Exception: Ducts conveying vapor or fumes having flammable constituents less than 25 percent of their lower flammable limit (LFL) are permitted to pass through other spaces.

Emissions generated at workstations shall be confined to the area in which they are generated as specified in the *California Fire Code* and the *California Mechanical Code*.

The location of supply and exhaust openings shall be in accordance with the *California Mechanical Code*. Exhaust air contaminated by highly toxic material shall be treated in accordance with the *California Fire Code*.

A manual shutoff control for ventilation equipment required by this section shall be provided outside the room adjacent to the principal access door to the room. The switch shall be of the break-glass type and shall be labeled: VENTILATION SYSTEM EMERGENCY SHUTOFF.

[F] 414.4 Hazardous material systems. Systems involving hazardous materials shall be suitable for the intended application. Controls shall be designed to prevent materials from entering or leaving process or reaction systems at other than the intended time, rate or path. Automatic controls, where provided, shall be designed to be fail safe.

[F] 414.5 Inside storage, dispensing and use. The inside storage, dispensing and use of hazardous materials in excess of the maximum allowable quantities per control area of Tables 307.1(1) and 307.1(2) shall be in accordance with Sections 414.5.1 through 414.5.5 of this code and the *California Fire Code*.

[F] 414.5.1 Explosion control. Explosion control shall be provided in accordance with the *California Fire Code* as required by Table 414.5.1 where quantities of hazardous

**[F] TABLE 414.2.2
DESIGN AND NUMBER OF CONTROL AREAS**

FLOOR LEVEL		PERCENTAGE OF THE MAXIMUM ALLOWABLE QUANTITY PER CONTROL AREA ^a	NUMBER OF CONTROL AREAS PER FLOOR	FIRE-RESISTANCE RATING FOR FIRE BARRIERS IN HOURS ^b
Above grade plane	Higher than 9	5	1	2
	7-9	5	2	2
	6	12.5	2	2
	5	12.5	2	2
	4	12.5	2	2
	3	50	2	1
	2	75	3	1
	1	100	4	1
Below grade plane	1	75	3	1
	2	50	2	1
	Lower than 2	Not Allowed	Not Allowed	Not Allowed

a. Percentages shall be of the maximum allowable quantity per control area shown in Tables 307.1(1) and 307.1(2), with all increases allowed in the notes to those tables.

b. Fire barriers shall include walls and floors as necessary to provide separation from other portions of the building.

SECTION 419
GROUP I-1, R-1, R-2, R-3, R-3.1, R-4

419.1 General. Occupancies in Groups I-1, R-1, R-2, R-3, R-3.1 and R-4 shall comply with the provisions of this section and other applicable provisions of this code.

419.2 Separation walls. Walls separating dwelling units in the same building and walls separating sleeping units in the same building shall comply with Section 708.

419.3 Horizontal separation. Floor/ceiling assemblies separating dwelling units in the same buildings and floor/ceiling assemblies separating sleeping units in the same building shall be constructed in accordance with Section 711.

419.4 Townhouses. [HCD 1] Each townhouse unit shall be considered a separate building and shall comply with the following:

1. Adjacent townhouse units shall each be provided with a 1-hour fire-resistance-rated wall assembly separating the units.
2. Openings are not permitted.
3. Penetrations shall comply with Section 712.

Exception: In lieu of the two 1-hour walls a common 2-hour fire-resistance-rated wall shall be permitted for townhouses if such walls do not contain plumbing or mechanical equipment, ducts or vents in the cavity of the common wall. Electrical installations shall be installed in accordance with the California Electrical Code. Penetrations of electrical outlet boxes shall be in accordance with Section 712.

For purposes of determining accessibility requirements to accommodate persons with disability, dwelling units within a single structure separated by a firewall do not constitute separate structures or buildings and are treated as a single building. For additional information, see Chapter 11A, Section 1102A.1.

419.4.1 Continuity. [HCD 1] The fire-resistance-rated wall or assembly separating townhouses shall be continuous from the foundation to the underside of the roof sheathing, deck or slab. The fire-resistance rating shall extend the full length of the wall or assembly, including wall extensions through and separating attached enclosed accessory structures.

419.4.2 Parapets. [HCD 1] Parapets constructed in accordance with Section 419.4.3 shall be constructed for townhouses as an extension of exterior walls or common walls in accordance with the following:

1. Where roof surfaces adjacent to the wall or walls are at the same elevation, the parapet shall extend not less than 30 inches (762 mm) above the roof surfaces.
2. Where roof surfaces adjacent to the wall or walls are at different elevations and the higher roof is not more than 30 inches (762 mm) above the lower roof, the parapet shall extend not less than 30 inches (762 mm) above the lower roof surface.

Exception: A parapet is not required in the two cases above when the roof is covered with a mini-

um Class C roof covering, and the roof decking or sheathing is of noncombustible materials or approved fire-retardant-treated wood for a distance of 4 feet (1219 mm) on each side of the wall or walls, or one layer of $\frac{5}{8}$ -inch (15.9 mm). Type X gypsum board is installed directly beneath the roof decking or sheathing, supported by a minimum of nominal 2-inch (51 mm) ledgers attached to the sides of the roof framing members, for a minimum distance of 4 feet (1220 mm) on each side of the wall or walls.

3. A parapet is not required where roof surfaces adjacent to the wall or walls are at different elevations and the higher roof is more than 30 inches (762 mm) above the lower roof. The common wall construction from the lower roof to the underside of the higher roof deck shall have not less than a 1-hour fire-resistance rating. The wall shall be rated for exposure from both sides.

419.4.3 Parapet construction. [HCD 1] Parapets shall have the same fire-resistance rating as that required for the supporting wall or walls. On any side adjacent to a roof surface, the parapet shall have noncombustible faces for the uppermost 18 inches (457 mm), to include counterflashing and coping materials. Where the roof slopes toward a parapet at slopes greater than two units vertical in 12 units horizontal (16.7-percent slope), the parapet shall extend to the same height as any portion of the roof within a distance of 3 feet (914 mm), but in no case shall the height be less than 30 inches (762 mm).

419.4.4 Structural independence. [HCD 1] Each individual townhouse shall be structurally independent.

Exceptions:

1. Foundations supporting exterior walls or common walls.
2. Structural roof and wall sheathing from each unit may fasten to the common wall framing.
3. Nonstructural wall coverings.
4. Flashing at termination of roof covering over common wall.
5. Townhouses separated by a common 2-hour fire-resistance-rated wall as provided in Section 419.4.

419.5 Licensed 24-hour care facilities in a Group I-1, R-3.1, or R-4 occupancy. [SFM] See Section 425.

419.6 Existing Group R occupancies. [SFM] See Chapter 34.

SECTION 420
HYDROGEN CUTOFF ROOMS

[F] 420.1 General. When required by the California Fire Code, hydrogen cutoff rooms shall be designed and constructed in accordance with this section.

[F] 420.2 Definitions. The following words and terms shall, for the purposes of this chapter and as used elsewhere in this code, have the meanings shown herein.

[F] GASEOUS HYDROGEN SYSTEM. An assembly of piping, devices and apparatus designed to generate, store, contain, distribute or transport a nontoxic, gaseous hydrogen-containing mixture having at least 95-percent hydrogen gas by volume and not more than 1-percent oxygen by volume. Gaseous hydrogen systems consist of items such as compressed gas containers, reactors and appurtenances, including pressure regulators, pressure relief devices, manifolds, pumps, compressors and interconnecting piping and tubing and controls.

[F] HYDROGEN CUTOFF ROOM. A room or space that is intended exclusively to house a gaseous hydrogen system.

[F] 420.3 Location. Hydrogen cut-off rooms shall not be located below grade.

[F] 420.4 Design and construction. Hydrogen cutoff rooms shall be classified with respect to occupancy in accordance with Section 302.1 and separated from other areas of the building by not less than 1-hour fire barriers or as required by Section 508.2 or 508.3 as applicable.

[F] 420.4.1 Opening protectives. Doors within such fire barrier walls, including doors to corridors, shall be self-closing in accordance with Section 715. Interior door openings shall be electronically interlocked to prevent operation of the hydrogen system when doors are opened or ajar or the room shall be provided with a mechanical exhaust ventilation system designed in accordance with Section 420.4.1.1.

[F] 420.4.1.1 Ventilation alternative. When an exhaust system is used in lieu of the interlock system required by Section 420.4, exhaust ventilation systems shall operate continuously and shall be designed to operate at a negative pressure in relation to the surrounding area. The average velocity of ventilation at the face of the door opening with the door in the fully open position shall not be less than 60 feet per minute (0.3048 m/s) with a minimum of 45 feet per minute (0.2287 m/s) at any point in the door opening.

[F] 420.4.2 Windows. Operable windows in interior walls shall not be permitted. Fixed windows shall be permitted when in accordance with Section 715.

[F] 420.5 Ventilation. Cutoff rooms shall be provided with mechanical ventilation in accordance with the applicable provisions for repair garages in Chapter 5 of the *California Mechanical Code*.

[F] 420.6 Gas detection system. Hydrogen cutoff rooms shall be provided with an approved flammable gas-detection system in accordance with Sections 420.6.1 through 420.6.3.

[F] 420.6.1 System design. The flammable gas-detection system shall be listed for use with hydrogen and any other flammable gases used in the room. The gas detection system shall be designed to activate when the level of flammable gas exceeds 25 percent of the lower flammability limit (LFL) for the gas or mixtures present at their anticipated temperature and pressure.

[F] 420.6.2 Operation. Activation of the gas detection system shall result in all of the following:

1. Initiation of distinct audible and visual alarm signals both inside and outside of the cutoff room.
2. Activation of the mechanical ventilation system.

[F] 420.6.3 Failure of the gas detection system. Failure of the gas detection system shall result in activation of the mechanical ventilation system, cessation of hydrogen generation and the sounding of a trouble signal in an approved location.

[F] 420.7 Explosion control. Explosion control shall be provided in accordance with Chapter 9 of the *California Fire Code*.

[F] 420.8 Standby power. Mechanical ventilation and gas detection systems shall be connected to a standby power system in accordance with Chapter 27.

SECTION 421 **Reserved**

SECTION 422 **Reserved**

SECTION 423 **Reserved**

SECTION 424 **Reserved**

SECTION 425 **SPECIAL PROVISIONS FOR LICENSED 24-HOUR** **CARE FACILITIES IN A GROUP I-1, R-3.1 or R-4** **OCCUPANCY [SFM]**

425.1 Scope. The provisions of this section shall apply to 24-hour care facilities in a Group I-1, R-3.1, or R-4 occupancy licensed by a governmental agency.

425.2 General. The provisions in this section shall apply in addition to general requirements in this code.

425.2.1 Restraint shall not be practiced in a Group I-1, R-3.1, or R-4 occupancies.

Exception: Occupancies which meet all the requirements for a Group I-3 occupancy.

425.2.2 Pursuant to Health and Safety Code Section 13133, regulations of the State Fire Marshal pertaining to occupancies classified as Residential Facilities (RF) and Residential-Care Facilities for the Elderly (RCFE) shall apply uniformly throughout the state and no city, county, city and county, including a charter city or charter county, or fire protection district shall adopt or enforce any ordinance or

local rule or regulation relating to fire and panic safety which is inconsistent with these regulations. A city, county, city and county, including a charter city or charter county may, pursuant to Health and Safety Code Section 13143.5, or a fire protection district may, pursuant to Health and Safety Code Section 13869.7, adopt standards more stringent than those adopted by the State Fire Marshal that are reasonably necessary to accommodate local climate, geological, or topographical conditions relating to roof coverings for Residential Care Facilities for the Elderly.

Exception: Local regulations relating to roof coverings in facilities licensed as a Residential Care Facility for the Elderly (RCFE) per Health and Safety Code Section 13133.

425.3 Building height and area provisions.

425.3.1 Group I-1, R-3.1 and R-4 shall be constructed in accordance with Table 503.

425.3.2 Limitations—six or less clients. Group R-3.1 occupancies where clients are housed above the first story, having more than two stories in height or having more than 3,000 square feet (279 m²) of floor area above the first story shall not be of less than 1-hour fire-resistance-rated construction throughout.

In Group R-3.1 occupancies housing a bedridden client, the client sleeping room shall not be located above or below the first story.

Exception: Clients who become bedridden as a result of a temporary illness as defined in Health and Safety Code Sections 1566.45, 1568.0832, and 1569.72. A temporary illness is an illness that persists for 14 days or less. A bedridden client may be retained in excess of the 14 days upon approval by the Department of Social Services and may continue to be housed on any story in a Group R-3.1 occupancy classified as a licensed residential facility.

Every licensee admitting or retaining a bedridden resident shall, within 48 hours of the resident's admission or retention in the facility, notify the local fire authority with jurisdiction of the estimated length of time the resident will retain his or her bedridden status in the facility.

425.3.3 Limitations—seven or more clients. Group R-4 occupancies where nonambulatory clients are housed above the first story and there is more than 3,000 square feet (279 m²) of floor area above the first story or housing more than 16 clients above the first story shall be constructed of not less than 1-hour fire-resistance-rated construction throughout.

425.3.4 Nonambulatory elderly clients. Group R-4 occupancies housing nonambulatory elderly clients shall be of not less than 1-hour fire-resistance-rated construction throughout.

425.4 Type of construction provisions.

425.4.1 Group I-1 occupancies are not permitted in nonfire-resistance-rated construction, see Health and Safety Code Section 13131.5.

425.5 Fire-resistance-rated construction provisions.

425.5.1 Smoke barriers required. Group I-1 and R-4 occupancies licensed as a Residential Care Facility (RCF) with individual floor areas over 6,000 square feet (557 m²) per floor, shall be provided with smoke barriers, constructed in accordance with Section 709.

Group I-1 occupancies housing bedridden clients shall be provided with smoke barriers constructed in accordance with Section 709 regardless of the number of clients.

When smoke barriers are required, the area within a smoke compartment shall not exceed 22,500 square feet (2090 m²) nor shall its travel distance exceed 200 feet (60 960 mm). Such smoke barriers shall divide the floor as equally as possible.

425.5.2 Smoke partitions. In Group I-1 and R-4 occupancies where smoke partitions are required, framing shall be covered with noncombustible materials having an approved thermal barrier with an index of not less than 15 in accordance with FM 4880, UL 1040, NFPA 286 or UL 1715.

425.6 Interior finish provision.

425.6.1 Interior wall and ceiling finish. Group R-3.1 occupancies housing a bedridden client shall comply with interior wall and ceiling finish requirements specified for Group I-2 occupancies in Table 803.5.

425.7 Fire protection system provisions.

425.7.1 Automatic sprinkler systems in Group I-1, R-3.1 and R-4 occupancies. An automatic sprinkler system shall be installed where required in Section 903.

425.7.2 Fire alarm systems in Group I-1 and R-4 occupancies. An approved fire alarm system shall be installed where required in Section 907.

425.7.3 Smoke alarms in Groups I-1, R-3.1, and R-4 occupancies. Smoke alarms shall be installed where required in Section 907.2.10

425.7.4 Hearing impaired. See Section 907.9.1.

425.8 Means of egress provisions.

425.8.1 General. In addition to the general means of egress requirements of Chapter 10, this section shall apply to Group I-1, R-3.1, and R-4 occupancies.

425.8.2 Number of exits.

425.8.2.1 Group I-1, R-3.1, and R-4 occupancies shall have a minimum of two exits.

Exception: Ancillary use areas or occupancies shall have egress as required by Section 1019.

425.8.3 Egress arrangements.

425.8.3.1 Egress through adjoining dwelling units shall not be permitted.

425.8.3.2 Group R-3.1 occupancies housing nonambulatory clients. In a Group R-3.1 occupancy, bedrooms used by nonambulatory clients shall have access to at least one of the required exits which shall conform to one of the following:

1. Egress through a hallway or area into a bedroom in the immediate area which has an exit directly to the exterior and the corridor/hallway is constructed consistent with the dwelling unit interior walls. The hallway shall be separated from common areas by a solid wood door not less than $1\frac{3}{8}$ inch (35 mm) in thickness, maintained self-closing or shall be automatic closing by actuation of a smoke detector installed in accordance with Section 715.4.7.
2. Egress through a hallway which has an exit directly to the exterior. The hallway shall be separated from the rest of the house by a wall constructed consistent with the dwelling unit interior walls and opening protected by a solid wood door not less than $1\frac{3}{8}$ inch (35 mm) in thickness, maintained self-closing or shall be automatic closing by actuation of a smoke detector installed in accordance with Section 715.4.7.
3. Direct exit from the bedroom to the exterior.
4. Egress through an adjoining bedroom which exits to the exterior.

425.8.3.3 Group R-3.1 occupancies housing bedridden clients. In Group R-3.1 occupancies housing a bedridden client, all of the following shall apply:

1. In Group R-3.1 occupancies housing a bedridden client, a direct exit to the exterior of the residence shall be provided from the client sleeping room.
2. Doors to a bedridden client's sleeping room shall be of a self-closing, positive latching $1\frac{3}{8}$ inch (35 mm) solid wood door. Such doors shall be provided with a gasket so installed as to provide a seal where the door meets the jam on both sides and across the top. Doors shall be maintained self-closing or shall be automatic closing by actuation of a smoke alarm in accordance with Section 715.4.7.
3. Group R-3.1 occupancies housing a bedridden client shall not have a night latch, dead bolt, security chain or any similar locking device installed on any interior door leading from a bedridden client's sleeping room to any interior area such as a corridor, hallway and/or general use areas of the residence in accordance with Chapter 10.

4. The exterior exit door to a bedridden client's sleeping room shall be operable from both the interior and exterior of the residence.

5. Every required exit doorway from a bedridden client's sleeping room shall be of a size as to permit the installation of a door not less than 3 feet (914 mm) in width and not less than 6 feet 8 inches (2032 mm) in height. When installed in exit doorways, exit doors shall be capable of opening at least 90 degrees (1.57 rad) and shall be so mounted that the clear width of the exit way is not less than 32 inches (813 mm).

425.8.3.4 Intervening rooms. A means of exit shall not pass through more than one intervening room. A means of egress shall not pass through kitchens, storerooms, closets, garages or spaces used for similar purposes.

Exception: Kitchens that do not form separate rooms by construction.

425.8.4 Corridors.

425.8.4.1 Unless specified by Section 425.8.4, corridors serving Group I-1 and Group R-4 occupancies shall comply with Section 1017.1.

425.8.4.2 The minimum clear width of a corridor shall be as follows:

1. Group I-1 occupancies shall have 60 inches (1524 mm) on floors housing nonambulatory clients and 44 inches (1118 mm) on floors housing only ambulatory clients.
2. Group R-4 occupancies shall have 44 inches (1118 mm) on floors housing clients.

Exceptions:

1. Corridors serving an occupant load of 10 or less shall not be less than 36 inches (914 mm) in width.
2. Corridors serving ambulatory persons only and having an occupant load of 49 or less shall not be less than 36 inches (914 mm) in width.
3. Group R-3.1 occupancies shall have 36 inches (914 mm) on floors housing clients.

In Group I-1 occupancies provided with fire sprinklers throughout and which are required to have rated corridors, door closers need not be installed on doors to client sleeping rooms.

425.8.4.3 In Group I-1 and Group R-3.1 occupancies having smoke barriers, cross-corridor doors in corridors 6 feet (1829 mm) or less in width shall have, as a minimum, a door 36 inches (914 mm) in width.

425.8.5 Changes in level. In Group R-3.1 occupancies housing nonambulatory clients, changes in level up to 0.25 inch (6 mm) may be vertical and without edge treatment. Changes in level between 0.25 inch (6 mm) and 0.5 inch (12.7 mm) shall be beveled with a slope no greater than 1 unit vertical in 2 units horizontal (50 percent slope).

Changes in level greater than 0.5 inch (12.7 mm) shall be accomplished by means of a ramp.

425.8.6 Stairways.

> **425.8.6.1** Group I-1 occupancies housing more than six nonambulatory clients above the first floor shall be provided with two vertical exit enclosures. Stairway enclosures shall be in compliance with Section 1020. Exceptions to Section 1020 shall not apply in facilities licensed as a 24-hour care facility.

425.8.6.2 Group R-3.1 occupancies may continue to use existing stairways (except for winding and spiral stairways which are not permitted as a required means of egress) provided the stairs have a maximum rise of 8 inches (203 mm) with a minimum run of 9 inches (229 mm). The minimum stairway width may be 30 inches (762 mm).

425.8.7 Floor separation. Group R-3.1 occupancies shall be provided with a nonfire resistance constructed floor separation at stairs which will prevent smoke migration between floors. Such floor separation shall have equivalent construction of 0.5 inch (12.7 mm) gypsum wallboard on one side of wall framing.

Exceptions:

1. Occupancies with at least one exterior exit from floors occupied by clients.
2. Occupancies provided with automatic fire sprinkler systems complying with Chapter 9.

425.8.7.1 Doors within floor separations. Doors within such floor separations shall be tight fitting solid wood at least $1\frac{3}{8}$ inches (35 mm) in thickness. Door glazing shall not exceed 1,296 square inches (32 918 mm²) with no dimension greater than 54 inches (1372 mm). Such doors shall be positive latching, smoke gasketed and shall be automatic-closing by smoke detection.

425.8.8 Fences and gates. Grounds of a residential care for the elderly facility serving Alzheimer's clients may be fenced and gates therein equipped with locks, provided safe dispersal areas are located not less than 50 feet (15 240 mm) from the buildings. Dispersal areas shall be sized to provide an area of not less than 3 square feet (0.28 m²) per occupant. Gates shall not be installed across corridors or passageways leading to such dispersal areas unless they comply with egress requirements.

425.8.9 Basement exits. One exit is required to grade level when the basement is accessible to clients.

425.8.10 Delayed egress locks. See Section 1008.1.8.6.

425.9 Request for alternate means of protection for facilities housing bedridden clients. Request for alternate means of protection shall apply to Sections 425 through 425.9. Request for approval to use an alternative material, assembly or materials, equipment, method of construction, method of installation of equipment or means of protection shall be made in writing to the local fire authority having jurisdiction by the facility, client or the client's authorized representative. Sufficient evidence shall be submitted to substantiate the need for an alternate means of protection.

The facility, client or the client's representative or the local fire authority having jurisdiction may request a written opinion from the State Fire Marshal concerning the interpretation of the regulations promulgated by the State Fire Marshal for a particular factual dispute. The State Fire Marshal shall issue the written opinion within 45 days following the request.

Approval of a request for use of an alternative material, assembly or materials, equipment, method of construction, method of installation of equipment, or means of protection made pursuant to this section shall be limited to Group R-3.1 occupancies housing a bedridden client.

Approvals made by the local fire authority having jurisdiction and the written opinion by the State Fire Marshal shall be applicable only to the requesting facility and shall not be construed as establishing any precedent for any future request by that facility or any other facility.

425.10 Temporarily bedridden clients. Clients who become temporarily bedridden as defined in Health and Safety Code Section 1569.72, as enforced by the Department of Social Services, may continue to be housed on any story in Group I-1, R-3.1, or R-4 occupancies classified as Residential Care Facilities for the Elderly (RCFE). Every Residential Care Facility for the Elderly (RCFE) admitting or retaining a bedridden resident shall, within 48 hours of the resident's admission or retention in the facility, notify the local fire authority with jurisdiction of the estimated length of time the resident will retain his or her bedridden status in the facility.

SECTION 426 GROUP I-4 [SFM]

426.1 Group I-4 special provisions. Rooms classified as Group I-4 shall not be located above or below the first story.

Exceptions:

1. Basements or stories having floor levels located within 4 feet (1219 mm), measured vertically, from adjacent ground level at the level of exit discharge, provided the basement or story has exterior exit doors at that level.
2. In buildings equipped with an automatic sprinkler system throughout, rooms used for day-care purposes may be located on the second story, provided there are at least two exterior exit doors for the exclusive use of such occupants
3. Group I-4 child care facilities may be located above the first story in buildings of Type I construction and in Types IIa, and IIIa construction, subject to the limitation of Section 503 when:
 - 3.1. Group I-4 child care facilities with children under the age of seven or containing more than 12 children per story shall not be located above the fourth floor; and
 - 3.2. The entire story in which the Group I-4 child care facility is located is equipped with an approved manual fire alarm and smoke detection system (see the California Fire Code).

Actuation of an initiating device shall sound an audible alarm throughout the entire story.

When a building fire alarm system is required by other provisions of this code or the California Fire Code, the alarm system shall be connected to the building alarm system. An approved alarm signal shall sound at an approved location in the Group I-4 child care facility to indicate a fire alarm or sprinkler flow condition in other portions of the building; and

- 3.3. Group I-4 child care facilities, if more than 1,000 square feet (92.9 m²) in area, is divided into at least two compartments of approximately the same size by a smoke barrier with door openings protected by smoke- and draft-control assemblies having a fire protection rating of not less than 20 minutes. Smoke barriers shall have a fire-resistive rating of not less than 1 hour. In addition to the requirements of Section 508.3.3, occupancy separations between Group I-4 child care and other occupancies shall be constructed as smoke barriers. Door openings in the smoke barrier shall be tightfitting, with gaskets installed as required by Section 709, and shall be automatic closing by actuation of the automatic sprinklers, fire alarm or smoke detection system; and
- 3.4. Each compartment formed by the smoke barrier has not less than two exits or exit access doors, one of which is permitted to pass through the adjoining compartment; and
- 3.5. Where two or more means of exits or exit access are required at least one shall not share a common path of travel; and
- 3.6. The building is equipped with an automatic sprinkler system throughout.

SECTION 427 **Reserved**

SECTION 428 **Reserved**

SECTION 429 **Reserved**

SECTION 430 **HORSE RACING STABLES [SFM]**

430.1 For automatic sprinkler and fire alarm system requirements applying to each building, barn or structure which is used by an association regulated by the California Horse Racing Board for the stabling of horses or human habitation, and the stable area grounds, including any additional location where any excess horses are stabled, see Title 4, Division 4, Article 17, Section 1927.

SECTION 431 **PET KENNELS [SFM]**

431.1 These regulations shall apply to every building or fire area in which a pet dealer, as defined in Health and Safety Code Section 122125, maintains a kennel.

431.2 Automatic sprinkler system. An approved automatic sprinkler system complying with California Fire Code Section 903 shall be installed.

Exception: Where a fire alarm system that is connected to a central reporting station that alerts the local fire department in case of fire.

SECTION 432 **COMBUSTION ENGINES AND GAS TURBINES [SFM]**

432.1 General. The installation of combustion engines and gas turbines shall be in accordance with NFPA 37 and this chapter.

432.2 Separation.

432.2.1 Construction. Every room in which is installed a combustion engine or gas turbine shall be separated from the remainder of the building by not less than a 1-hour fire barrier.

432.2.2 Exterior openings. When doors, windows or louvered openings are located below openings in another story or less than 10 feet (3048 mm) from doors, windows or louvered openings of the same building, they shall be protected by a fire assembly having a ³/₄-hour rating. Such fire assemblies shall be fixed, automatic or self-closing.

432.2.2.1 Interior openings. In other than buildings housing Group I occupancies, interior openings shall be allowed in buildings protected by an automatic fire sprinkler system throughout.

432.2.3 Location. Combustion engines and gas turbines used for emergency power shall not be located in a room or area used for any purpose other than equipment and controls related to the generation and distribution of emergency power.

432.2.4 Special hazards. The handling and use of flammable or combustible liquids shall comply with the California Fire Code.

SECTION 433 **FIXED GUIDEWAY TRANSIT SYSTEMS [SFM]**

433.1 General.

433.1.1 Scope. The provisions of this section shall apply to buildings or structures defined as stations for fixed guideway transit systems and shall supersede other similar requirements in other sections of this code.

433.1.2 Definitions. For the purpose of this section, certain terms are defined as follows:

AT-GRADE STATION is any at-grade or unroofed station other than an elevated or underground station.

lowed when specific weights of special effects materials in the amount of 1 pound (0.454 kg) or more are involved:

Weight of Explosive	Structure of Shield Wall
1 to 15 pounds (0.454-6.8 kg)	Shield wall constructed of concrete not less than 12 inches (305 mm) thick which is reinforced near both sides by rods not less than 1/2 inch (12.7 mm) in diameter located on maximum centers of 12 inches (305 mm) both horizontally and vertically. The rods must be staggered on opposite faces.
More than 15 pounds (6.8 kg)	The shield wall for the protection of workers must be designed in such a manner to protect against the efforts of not less than 25 percent overload above the expected maximum charge to be processed.

Notes:

1. One inch (25 mm) of mild steel is equivalent to 1 foot (305 mm) of reinforced concrete.
2. Explosives shall be located not less than 36 inches (914 mm) from the wall and 24 inches (610 mm) above the floor.

If this personnel protection wall for the required operation involving large quantities of special effects materials becomes so large that it is impractical, the operator must perform the operations by remote control or be protected by a suitably constructed shelter designed with a safety factor of not less than 4 to withstand the overpressure from the maximum amount of explosives in process.

**SECTION 435
Reserved**

**SECTION 436
WINERY CAVES [SFM]**

436.1 Scope. The use of subterranean space for winery facilities in natural or manmade caves shall be in accordance with this section.

436.2 Definitions.

436.3 General. For definitions of "Assembly, fire appliance" and "Noncombustible," see Chapter 2.

436.4 Limited application. For the purpose of Section 436, certain terms are defined as follows:

TYPE 1 WINERY CAVES. Natural or manmade caves used solely for storage and/or processing of wine at a winery facility. Type 1 winery caves are not accessible to the public.

TYPE 2 WINERY CAVES. Natural or manmade caves used for the storage and/or processing of wine at a winery

facility. Type 2 winery caves are accessible to the public on guided tours only.

TYPE 3 WINERY CAVES. Natural or manmade caves used for the storage and/or processing of wine at a winery facility. Type 3 winery caves are accessible to the public on guided tours and contain assembly use areas.

436.5 Permits. For permits to operate Type 2 and 3 winery caves, see Appendix Chapter 1, Section 105.

436.6 Fire apparatus access roads Fire apparatus access roads shall be constructed and maintained in accordance with the California Fire Code, Section 503.

436.7 Construction requirements.

436.7.1 Allowable area. The area of winery caves shall not be limited if constructed entirely of noncombustible materials.

Winery caves constructed with combustible materials shall be limited in area so that no point is more than 150 feet (45 720 mm) from an exit.

436.7.2 Interior construction. The walls and ceilings of winery caves shall not contain hidden or concealed spaces.

436.8 General requirements.

436.8.1 Public tours. Tours for the public shall be continuously guided by staff knowledgeable in the location of exits and the use of emergency notification devices.

436.8.2 Standby personnel. In accordance with the California Fire Code, Section 2404.20, when, in the opinion of the fire chief, it is essential for public safety, the owner, agent or lessee shall employ one or more qualified persons, as required and approved by the chief, to be on duty at such place. Such individuals shall be in uniform or otherwise easily identifiable.

Standby personnel shall be subject to the fire chief's orders at all times when so employed and shall remain on duty during the times such places are open to the public or when such activity is being conducted.

Before the start of any activity requiring standby personnel, such individuals shall:

1. Inspect the required fire appliances to ensure they are in the proper place and in good working order.
2. Inspect all exits to verify accessibility and proper operation.

While on duty, such individuals shall not be required or permitted to perform any duties other than those specified by the fire chief.

436.8.3 Open-flame devices. The use of candles and other open-flame devices shall be in accordance with California Fire Code, Section 308.3.5.

436.9 Portable fire extinguishers and other fire appliances. Portable fire extinguishers shall be located to be readily accessible. Their type, location and spacing throughout the facility shall be in accordance with the provisions of Title 19, Chapter 3 and California Fire Code, Section 906.1. Other fire appliances shall be maintained at the site as required by the fire chief.

436.10 Fire alarm systems. An approved manual fire alarm system conforming with the provisions of the California Fire Code, Section 907.2.1, shall be provided in all Type 3 winery caves.

436.11 Exits.

436.11.1 Distribution. Exits shall be located remotely from each other and arranged to minimize any possibility that more than one may be blocked off by any one fire or other emergency condition.

436.11.2 Number. Winery caves shall be provided with a minimum of two exits. Assembly areas of Type 3 winery caves shall be provided with exits as required by the California Building Code for Group A occupancies.

436.12 Exit illumination.

436.12.1 General. Exits shall be illuminated to a minimum intensity of not less than 1 foot-candle (10.76 lux) at floor level whenever the winery cave is occupied. Fixtures providing exit illumination shall be supplied from a dedicated circuit or source of power used only for exit illumination.

436.12.2 Separate sources of power. The power supply for exit illumination may be provided by the premises' wiring system. In the event of its failure, illumination shall be automatically provided from an emergency system in Type 2 and 3 winery caves. Emergency systems shall be supplied from storage batteries or an on-site generator set, and the system shall be installed in accordance with the requirements of the California Electrical Code.

436.13 Exit signs. Exit signs shall be installed at required exits and where otherwise necessary to clearly indicate the exits from assembly areas in Type 3 winery caves.

436.14 Maximum occupant load. Occupant load requirements in the assembly areas of Type 3 winery caves shall be in accordance with Section 1004.

436.15 Seating arrangements. Seating arrangements in the assembly areas of Type 3 winery caves shall be in accordance with California Fire Code, Section 1025.10.

**SECTION 437
Reserved**

**SECTION 438
Reserved**

**SECTION 439
PUBLIC LIBRARIES [SL & SFM]**

Public libraries funded from the California Library Construction and Renovation Act of 1988.

439.1 Automatic sprinkler system. Automatic sprinkler systems shall be installed in:

1. New facilities, including additions;
2. Existing facilities to which a project adds the lesser of 5,000 square feet (465m²) or 10 percent of the size of the

existing facility, if the existing facility does not already have an automatic sprinkler system.

439.1.1 Fire extinguishment. Fire-extinguishing systems meeting the standards in Chapter 9 and approved by the local fire authority shall be installed in:

New facilities, including additions;

Existing facilities to which a project adds the lesser of 5,000 square feet (465m²) or 10 percent of the size of the existing facility, if the existing facility does not already have an automatic sprinkler system.

439.2 System monitoring requirement. All fire protection systems shall be monitored by a fire alarm supervising station in accordance with NFPA 72.

439.2.1 Signaling system. Fire-extinguishing systems installed in accordance with the preceding subsection shall be connected to a remote station protection signaling system conforming to NFPA 72.

Exception: The extinguishment and signaling requirements of this chapter do not apply to projects of less than 5,000 gross square feet (465 m²) that do not have adequate water flow available, except that any interior book return with a slot piercing the exterior wall shall be enclosed in fire-rated construction.

439.3 Book return slots. Any interior book return with a slot piercing the exterior wall shall have a separate sprinkler head and be enclosed in fire-rated construction.

439.4 Automatic sprinkler and extinguishing systems. For public libraries constructed with funds awarded under the California Reading and Literacy Improvement and Public Library Construction and Renovation Bond Act of 2000:

1. **Fire sprinkler system requirement.** All libraries funded for new construction, including additions, shall have automatic fire sprinkler systems installed.
2. **Fire sprinkler system requirement for renovations of existing facilities.** If there is no automatic fire sprinkler system in the existing facility, grant recipients shall be required to install a fire sprinkler system throughout the existing facility.
3. **Fire sprinkler system types.** The grant recipient may choose, on approval by the local fire authority, from wet-pipe, dry-pipe or pre-action systems, utilizing listed standard, early suppression fast response (ESFR) or on/off-type sprinkler heads.
4. **Book return rooms and slots.** Book return rooms with slots in exterior walls shall have an automatic sprinkler head and be of approved fire-resistive construction. Book return slots and book drops shall have an additional automatic sprinkler head when shielded from the room sprinkler head.
5. **System monitoring requirement.** All fire protection systems shall be monitored by a fire alarm supervising station in accordance with NFPA 72.
6. **Alternate fire-extinguishing systems for specialized areas.** When approved by the fire authority having jurisdiction, other types of approved automatic

boiler used as part of the heating system shall be separated from the rest of the building by a 1-hour fire-resistive fire barrier with all openings protected as set forth in Section 706.7.

Exceptions:

1. Boilers or central heating plants where the largest piece of fuel equipment does not exceed 400,000 Btu per hour (135 kW) input.
2. When any such opening is protected by a pair of fire doors, the inactive leaf shall be normally secured in the closed position and shall be openable only by use of a tool. An astragal shall be provided and the active leaf shall be self-closing.

440.7.7 Exits. For purposes of determining occupant load for exit requirements, see Section 440.3.2.

440.7.8 Liquefied petroleum gas. The construction and installation of all tanks, cylinders, equipment and systems used or intended for use in conjunction with any liquefied petroleum gas shall conform to the provisions of the California Mechanical Code and the California Fire Code.

440.7.9 Air-conditioning and ventilation systems. Heating units used as an integral part of an air-conditioning and ventilation system shall be installed in accordance with Sections 440.7.2, 440.7.3 and 440.7.6.

440.8 Camp fire alarm. Every organized camp shall provide and maintain a device or devices suitable for sounding a fire alarm. Such device or devices may be of any type acceptable to the enforcing agency provided they are distinctive in tone from all other signaling devices or systems and shall be audible throughout the camp premises. When an automatic fire alarm system is provided, as required by Section 440.6.6, all signaling devices required by this section shall be of the same type as that used in the automatic system.

**SECTION 441
Reserved**

**SECTION 442
GROUP E [SFM]**

442.1 Location on property. All buildings housing Group E occupancies shall front directly on a public street or an exit discharge not less than 20 feet (6096 mm) in width. The exit discharge to the public street shall be a minimum 20-foot-wide (6096 mm) right-of-way, unobstructed and maintained only as access to the public street. At least one required exit shall be located on the public street or on the exit discharge.

442.2 Separate means of egress systems required. Every room with an occupant load of 300 or more shall have one of its exits or exit-access doorways lead directly into a separate means of egress system that consists of not less than two paths of exit travel which are separated in such a manner to provide an atmospheric separation that precludes contamination of both paths of exit travel by the same fire. Not more than two required exits or exit-access doorways shall enter into the same means of egress system.

442.3 Fences and gates. School grounds may be fenced and gates therein may be equipped with locks, provided that safe dispersal areas based on 3 square feet (0.28 m²) per occupant are located between the school and the fence. Such required safe dispersal areas shall not be located less than 50 feet (15 240 mm) from school buildings.

Every public and private school shall conform with Section 32020 of the Education Code which states:

The governing board of every public school district, and the governing authority of every private school, which maintains any building used for the instruction or housing of school pupils on land entirely enclosed (except for building walls) by fences or walls, shall, through cooperation with the local law enforcement and fire protection agencies having jurisdiction of the area, make provision for the erection of gates in such fences or walls. The gates shall be of sufficient size to permit the entrance of the ambulances, police equipment and fire-fighting apparatus used by the law enforcement and fire protection agencies. There shall be no less than one such access gate and there shall be as many such gates as needed to ensure access to all major buildings and ground areas. If such gates are to be equipped with locks, the locking devices shall be designed to permit ready entrance by the use of the chain or bolt-cutting devices with which the local law enforcement and fire-protection agencies may be equipped.

442.4 Special provisions. Rooms in Group E day care, kindergarten, first-, or second-grade pupils shall not be located above or below the first story.

Exceptions:

1. Basements or stories having floor levels located within 4 feet (1219 mm), measured vertically, from adjacent ground level at the level of exit discharge, provided the basement or story has exterior exit doors at that level.
2. In buildings equipped with an automatic sprinkler system throughout, rooms used for kindergarten, first- and second-grade children or for day care purposes may be located on the second story, provided there are at least two exterior exit doors for the exclusive use of such occupants.
3. Group E day-care facilities may be located above the first story in buildings of Type IA, 1B, IIA and IIIA construction, subject to the limitation of Section 503 when:
 - 3.1. Facilities with children under the age of seven or containing more than 12 children per story shall not be located above the fourth floor; and
 - 3.2. The entire story in which the day-care facility is located is equipped with an approved manual fire alarm and smoke detection system. Actuation of an initiating device shall sound an audible alarm throughout the entire story.

When a building fire alarm system is required by other provisions of this code, the alarm system shall be interconnected and sound the day-care fire alarm system; and

- 3.3. The day-care facility, if more than 1,000 square feet (92.9 m²) in area, is divided into at least two compartments of approximately the same size by a smoke barrier in accordance with Section 709. In addition to the requirements of Section 508, occupancy separations between day-care and other occupancies shall be constructed as smoke barriers. Door openings in the smoke barrier shall be tightfitting, with gaskets installed as required by Section 715.4.3 and shall be automatic closing by actuation of the fire sprinklers, fire alarm or smoke detection system; and
- 3.4. Each compartment formed by the smoke barrier has not less than two exits or exit-access doors, one of which is permitted to pass through the adjoining compartment; and
- 3.5. Where two or more means of exits or exit access are required at leased one shall not share a common path of travel; and
- 3.6. The building is equipped with an automatic sprinkler system throughout.

442.5 Special hazards. School classrooms constructed after January 1, 1990, not equipped with automatic sprinkler systems, which have metal grilles or bars on all their windows and do not have at least two exit doors within 3 feet (914 mm) of each end of the classroom opening to the exterior of the building or to a common hallway used for evacuation purposes, shall have an inside release for the grilles or bars on at least one window farthest from the exit doors. The window or windows with the inside release shall be clearly marked as emergency exits.

442.5.1 Class I, II or III-A flammable liquids shall not be placed, stored or used in Group E occupancies, except in approved quantities as necessary in laboratories and classrooms and for operation and maintenance as set forth in the California Fire Code.

SECTION 443 GROUP L [SFM]

443.1 Scope. The provisions of this section shall apply to buildings or structures, or portions thereof, containing one or more Group L laboratory suites as defined in Section 443.2.

443.2 Definitions.

LABORATORY SUITE. A laboratory suite is a space within a building or structure, which may include multiple laboratories, offices, storage, equipment rooms or similar support functions, where the aggregate quantities of hazardous materials stored and used do not exceed the quantities set forth in Table 443.7.3.1.

[F] LIQUID TIGHT FLOOR. A nonpermeable barrier capable of containing hazardous material liquids without degradation.

443.3 Laboratory suite requirements.

443.3.1 The gross square footage of an individual laboratory suite shall not exceed 10,000 sq ft. (929m²).

443.3.2 An individual laboratory suite shall not serve more than a single tenant.

Exception: A laboratory suite controlled by a single responsible party.

443.4 Construction.

443.4.1 Separation of laboratory suites.

443.4.1.1 Laboratory suites shall be separated from other occupancies in accordance with Table 508.3.3.

443.4.1.2 Laboratory suites shall be separated from other laboratory suites by a fire barrier having a fire-resistance rating of not less than 1-hour.

443.4.1.3 Laboratory suites shall be separated from control areas by a minimum 2-hour fire-resistance rating in accordance with Sections 706 and 711.

Exception: Laboratory suites shall be separated from control areas by a minimum 1-hour fire-resistance rating on floor levels below the 4th story.

443.4.1.4 Horizontal separation. The floor construction of the laboratory suite and the construction supporting the floor of the laboratory suite shall have a minimum 2-hour fire-resistance rating in accordance with Section 711.

Exceptions:

1. The floor construction of the laboratory suite and the construction supporting the floor of the laboratory suite are allowed to be 1-hour fire-resistance rated in buildings of Type IIA, IIIA and VA construction.
2. When an individual laboratory suite occupies more than one story, the intermediate floors contained within the suite shall comply with the requirements of Table 601.

443.4.2 Structural design occupancy category.

443.4.2.1 Buildings containing Group L occupancies with an occupant load greater than 500 for colleges or adult education facilities, or other buildings with an occupant load greater than 5,000 shall be classified as Occupancy Category III in accordance with Chapters 16 and 16A.

443.4.2.2 Other buildings containing Group L occupancies shall be classified as Occupancy Category II in accordance with Chapters 16 and 16A.

443.4.3 Fire barrier. A fire barrier having a fire resistance rating of not less than two hours shall divide any floor above the 4th story containing more than one laboratory suite.

443.4.3.1 Fire barriers shall be continuous from exterior wall to exterior wall.

443.4.3.2 The fire barrier shall divide the floor so that the square footage on each side of the 2-hour fire barrier is not less than 30 percent of the total floor area, and

443.4.3.3 The number of laboratory suites on each side of the 2-hour fire barrier shall not be less than 25% of the total number of laboratory suites on the floor.

443.4.4 Emergency response equipment area. An area for emergency response equipment shall be provided on each floor in an approved location. The area shall be a minimum of 50 square feet (4.6 m²) accessed from outside the laboratory suite and identified with signage.

443.4.5 Liquid tight floor. All portions of the laboratory suite where hazardous materials may be present shall be provided with a liquid-tight floor. Where the floor is designed to provide spill control or secondary containment, the floor shall be designed in accordance with California Fire Code Section 2704.2.

443.4.6 Emergency power. An emergency power system shall be provided in accordance with Chapter 27.

443.4.6.1 Required systems. Emergency power shall be provided for all electrically operated equipment, systems and connected control circuits including:

1. Mechanical ventilation systems. See section 443.4.7.
2. Emergency alarm and monitoring systems.
3. Temperature control systems required to prevent unsafe process excursions or chemical reactions.
4. Treatment systems and scrubbers.
5. Egress lighting.
6. Electrically operated systems required elsewhere in this code and the California Fire Code.

443.4.7 Ventilation.

443.4.7.1 Compatibility. Incompatible materials shall not be conveyed in the same duct system. Combined products in mechanical exhaust ducts shall not create a physical hazard or reaction that could degrade the duct material. The building official may require a technical report in accordance with Section 443.7.1.

443.4.7.2 Fire dampers, smoke dampers and combination fire/smoke dampers. Fire dampers, smoke dampers or fire/smoke dampers shall not be permitted in product conveying and other mechanical exhaust duct systems used to maintain a safe laboratory environment. When the exhaust duct penetrates the laboratory suite boundary the exhaust duct shall be located within a horizontal assembly having a fire resistance rating equal to the fire barrier.

443.4.7.3 Duct materials. Product conveying and other mechanical exhaust duct systems used to maintain a safe laboratory environment shall be constructed in accordance with Chapters 5 and 6 of the California Mechanical Code.

443.4.7.4 Laboratory suite exhaust air.

443.4.7.4.1 Exhaust air from laboratory suites shall not be recirculated.

443.4.7.4.2 Laboratory suite exhaust air shall be independently ducted to a point outside the building or a roof top structure.

Exceptions:

1. Exhaust ducts serving a single laboratory suite.
2. Exhaust ducts serving separate laboratory suites on the same story may be connected to a common duct within a fire rated vertical shaft when the subducts extend vertically upward at least 22 inches.
3. Exhaust ducts serving separate laboratory suites on the basement through the 4th story may be connected to a common duct within a fire rated vertical shaft when the subducts extend vertically upward at least 22 inches.
4. Exhaust ducts serving separate laboratory suites on the 5th story and above may be connected to a common duct that does not exceed 100 vertical feet within a fire rated vertical shaft when the subducts extend vertically upward at least 22 inches. Ducts serving the 5th story and above shall be separate from the duct serving the 4th story and below, but may be within the same fire-rated shaft.

443.4.7.4.3 Laboratory suite exhaust ducts shall not penetrate the 2-hour fire barrier required by Section 443.4.3.

Exception: Where the exhaust duct is enclosed in a 2-hour shaft in accordance with Section 707.

443.4.7.5 Ventilation rates. Mechanical exhaust ventilation systems shall provide a minimum ventilation rate not less than 1 cubic feet per minute per square foot [0.00508 m³/(s•m²)] of floor area, or six air exchanges per hour, whichever is greater. Systems shall operate

443.4.7.6 Mechanical ventilation systems on emergency power. When operating on emergency power, the ventilation rate may be reduced to a level sufficient to maintain a differential pressure negative to the surrounding area.

443.4.7.7 Mechanical ventilation system balancing. Mechanical ventilation systems shall be designed and balanced such that during normal and emergency conditions the door opening forces comply with the requirements of Sections 1008.1.2 and 1133B.2.5 as applicable. Emergency conditions shall include: supply fan shut-down or failure, closing of smoke dampers or combination fire/smoke dampers, or emergency power.

443.5 Fire protection systems. See Chapter 9.

443.6 Means of egress

443.6.1 Access to exits. Every portion of a laboratory suite containing hazardous materials and having a floor area of

500 square feet (19 m²) or more shall have access to not less than two separate exits or exit-access doorways in accordance with Section 1015.2.

443.6.2 Door swing. All exit and exit-access doors serving areas with hazardous materials shall swing in the direction of exit travel, regardless of the occupant load served.

443.6.3 Panic hardware. Exit and exit access doors from areas with hazardous materials shall not be provided with a latch or lock unless it is panic hardware or fire exit hardware.

443.6.4 Buildings more than 4 stories. A minimum of one exit shall be provided to serve the floor on each side of the 2-hour fire barrier and shall comply with the provisions of Chapter 10.

443.6.5 Corridors. Corridors shall comply with Section 1017 and shall have opening protection in accordance with Tables 715.4, 715.5 and 715.5.3.

443.7 Hazardous materials.

443.7.1 Technical report. The enforcing agency may require a technical opinion and report to identify and develop methods of protection from the hazards presented by the hazardous materials. A qualified person, firm, or corporation, approved by the enforcing agency, shall prepare the opinion and report, and shall be provided without charge to the enforcing agency. The opinion and report may include, but is not limited to, the preparation of a hazardous material management plan (HMMP); chemical analysis; recommendations for methods of isolation, separation, containment or protection of hazardous materials or processes, including appropriate engineering controls to be applied; the extent of changes in the hazardous behavior to be anticipated under conditions of exposure to fire or from hazard control procedures; and the limitations or conditions of use necessary to achieve and maintain control of the hazardous materials or operations. The report shall be entered into the files of the code enforcement agencies. Proprietary and

trade secret information shall be protected under the laws of the state or jurisdiction having authority.

443.7.2 Multiple hazards. When a hazardous material has multiple hazards, all hazards shall be addressed and controlled in accordance with the provisions of this code.

443.7.3 Percentage of maximum allowable quantities. The percentage of the maximum allowable quantity of hazardous materials per laboratory suite permitted for each story level within a building shall be in accordance with Table 443.7.3.1.

443.8 Existing Group L (Formerly Group H-8) occupancies, additions, alterations or repairs. See Section 3414.

**SECTION 444
Reserved**

**SECTION 445
LARGE-FAMILY DAY CARE HOMES [SFM]**

445.1 Large-family day care homes.

445.2 For purposes of clarification, Health and Safety Code Section 1597.46 is repeated.

(a) A city, county, or city and county shall not prohibit large-family day care homes on lots zoned for single-family dwellings, but shall do one of the following:

(1) Classify these homes as a permitted use of residential property for zoning purposes.

(2) Grant a nondiscretionary permit to use a lot zoned for a single-family dwelling to any large-family day care home that complies with local ordinances prescribing reasonable standards, restrictions and requirements concerning spacing and concentration, traffic control, parking and noise control relating to such homes, and complies with subdivision (d) and any regulations adopted by the State Fire Marshal pursuant to that subdivi-

**TABLE 443.7.3.1
HAZARDOUS MATERIALS QUANTITY PER LABORATORY SUITE**

STORY	PERCENTAGE OF THE MAXIMUM ALLOWABLE QUANTITY PER LABORATORY SUITE ^{a, b}	
Above grade plane	7 and above	50
	4, 5 and 6	75
	1, 2 and 3	100
Below grade plan	1	100 ^c
	2	75 ^d
	3 and below	0

^aPercentages shall be of the maximum allowable quantity per laboratory suite shown in Tables 307.1(1) and 307.1(2). Allowable hazardous material increases for buildings equipped throughout with an automatic sprinkler system shall not be applicable to Group L Occupancies.

^bWhen an individual laboratory suite occupies more than one story, the more restrictive percentage of the maximum allowable quantity per laboratory suite shall apply.

^cThe total aggregate quantity of flammable liquids on the first floor level below grade shall be limited to the maximum total aggregate quantity for Group B occupancy control areas.

^dThe total aggregate quantity of flammable liquids on the second floor level below grade shall be limited to a maximum total aggregate quantity for Group B occupancy control areas.

vision. Any noise standards shall be consistent with local noise ordinances implementing the noise element of the general plan and shall take into consideration the noise level generated by children. The permit issued pursuant to this paragraph shall be granted by the zoning administrator, if any, or if there is no zoning administrator by the person or persons designated by the planning agency to grant such permits, upon the certification without a hearing.

(3) Require any large-family day care home to apply for a permit to use a lot zoned for single-family dwellings. The zoning administrator, if any, or if there is no zoning administrator, the person or persons designated by the planning agency to handle the use permits shall review and decide the applications. The use permit shall be granted if the large family day care home complies with local ordinances, if any, prescribing reasonable standards, restrictions and requirements concerning spacing and concentration, traffic control, parking and noise control relating to such homes, and complies with subdivision (d) and any regulations adopted by the State Fire Marshal pursuant to that subdivision.

Any noise standards shall be consistent with local noise ordinances implementing the noise element of the general plan and shall take into consideration the noise levels generated by children.

The local government shall process any required permit as economically as possible, and fees charged for review shall not exceed the costs of the review and permit process. Not less than 10 days prior to the date on which the decision will be made on the application, the zoning administrator or person designated to handle such use permits shall give notice of the proposed use by mail or delivery to all owners shown on the last equalized assessment roll as owning real property within a 100 (30 480 mm) foot radius of the exterior boundaries of the proposed large-family day-care home. No hearing on the application for a permit issued pursuant to this paragraph shall be held before a decision is made unless a hearing is requested by the applicant or other affected person. The applicant or other affected person may appeal the decision. The appellant shall pay the cost, if any, of the appeal.

(b) A large-family day care home shall not be subject to the provisions of Division 13 (commencing with Section 21000) of the Public Resources Code.

(c) Use of a single-family dwelling for the purposes of a large family day care home shall not constitute a change of occupancy for purposes of Part 1.5 (commencing with Section 17910) of Division 13 (State Housing Law), or for purposes of local building and fire codes.

(d) Large-family day care homes shall be considered as single-family residences for the purposes of the State Uniform Building Standards Code and local building and fire codes, except with respect to any additional standards specifically designed to promote the fire and life safety of the children in these homes adopted by the State Fire Marshal pursuant to this subdivision.

445.3 Smoke alarms. Large-family day care homes shall be equipped with State Fire Marshal approved and listed single-station residential-type smoke alarms. The number and placement of smoke alarms shall be determined by the enforcement authority.

445.4 Fire extinguishers. Large- and small-family day care homes shall be equipped with a portable fire extinguisher having a minimum 2A10BC rating.

445.5 Fire alarm devices. Every large-family day care home shall be provided with at least one manual device at a location approved by the authority having jurisdiction. Such device shall actuate a fire alarm signal, which shall be audible throughout the facility at a minimum level of 15 db above ambient noise level. These devices need not be interconnected to any other fire alarm device, have a control panel or be electrically supervised or provided with emergency power. Such device or devices shall be attached to the structure and may be of any type acceptable to the enforcing agent, provided that such devices are distinctive in tone and are audible throughout the structure.

445.6 Compliance. Every large-family day-care home shall comply with the provisions for Group R-3 occupancies and, if appropriate, Section 426.1. For the purposes of Section 426.1, the first story shall be designated as the floor used for residential occupancy nearest to the street level which provides primary access to the building.

Enforcement of these provisions shall be in accordance with the Health and Safety Code Sections 13145 and 13146. No city, county, city and county, or district shall adopt or enforce any building ordinance or local rule or regulation relating to the subject of fire and life safety in large-family day-care homes which is inconsistent with those standards adopted by the State Fire Marshal, except to the extent the building ordinance or local rule or regulation applies to single-family residences in which day care is not provided.

445.7 Special hazards. Every unenclosed gas-fired water heater or furnace which is within the area used for child care in a large-family day care home shall be protected in such a way as to prevent children from making contact with those appliances.

Exception: This does not apply to kitchen stoves or ovens.

445.8 Exiting. Every story or basement of a large family day-care home shall be provided with two exits which are remotely located from each other. Every required exit shall be of a size to permit the installation of a door not less than 32 inches (813 mm) in clear width and not less than 6 feet 8 inches (2032 mm) in height. A manually operated horizontal sliding door may be used as one of the two required exits.

Where basements are used for day-care purposes, one of the two required exits shall provide access directly to the exterior without entering the first story. The second exit from the basement may either pass through the story above or exit directly to the exterior.

Rooms used for day-care purposes shall not be located above the first story.

SPECIAL DETAILED REQUIREMENTS BASED ON USE AND OCCUPANCY

Exception: Buildings equipped with an automatic sprinkler system throughout and which have at least one of the required exits providing access directly to the exterior. NFPA 13R or NFPA 13D may be used in large family day-care homes. Section 206 of NFPA 13R or NFPA 13D shall not apply unless approved by the authority having jurisdiction.

Section 1004.1.1 is not applicable to this occupancy classification.

CHAPTER 5

GENERAL BUILDING HEIGHTS AND AREAS

SECTION 501 GENERAL

501.1 Scope. The provisions of this chapter control the height and area of structures hereafter erected and additions to existing structures.

[F] 501.2 Address numbers. Buildings shall have approved address numbers, building numbers or approved building identification placed in a position that is plainly legible and visible from the street or road fronting the property. These numbers shall contrast with their background. Address numbers shall be Arabic numerals or alphabetical letters. Numbers shall be a minimum of 4 inches (102 mm) high with a minimum stroke width of 0.5 inch (12.7 mm).

SECTION 502 DEFINITIONS

502.1 Definitions. The following words and terms shall, for the purposes of this chapter and as used elsewhere in this code, have the meanings shown herein.

AREA, BUILDING. The area included within surrounding exterior walls (or exterior walls and fire walls) exclusive of vent shafts and courts. Areas of the building not provided with surrounding walls shall be included in the building area if such areas are included within the horizontal projection of the roof or floor above.

BASEMENT. That portion of a building that is partly or completely below grade plane (see “Story above grade plane” in Section 202). A basement shall be considered as a story above grade plane where the finished surface of the floor above the basement is:

1. More than 6 feet (1829 mm) above grade plane; or
2. More than 12 feet (3658 mm) above the finished ground level at any point.

EQUIPMENT PLATFORM. An unoccupied, elevated platform used exclusively for mechanical systems or industrial process equipment, including the associated elevated walkways, stairs and ladders necessary to access the platform (see Section 505.5).

GRADE PLANE. A reference plane representing the average of finished ground level adjoining the building at exterior walls. Where the finished ground level slopes away from the exterior walls, the reference plane shall be established by the lowest points within the area between the building and the lot line or, where the lot line is more than 6 feet (1829 mm) from the building, between the building and a point 6 feet (1829 mm) from the building.

HEIGHT, BUILDING. The vertical distance from grade plane to the average height of the highest roof surface.

HEIGHT, STORY. The vertical distance from top to top of two successive finished floor surfaces; and, for the topmost story, from the top of the floor finish to the top of the ceiling joists or, where there is not a ceiling, to the top of the roof rafters.

MEZZANINE. An intermediate level or levels between the floor and ceiling of any story and in accordance with Section 505.

SECTION 503 GENERAL HEIGHT AND AREA LIMITATIONS

503.1 General. The height and area for buildings of different construction types shall be governed by the intended use of the building and shall not exceed the limits in Table 503 except as modified hereafter. Each part of a building included within the exterior walls or the exterior walls and fire walls where provided shall be permitted to be a separate building.

Exception: [HCD 1] Limited-density owner-built rural dwellings may be of any type of construction which will provide for a sound structural condition. Structural hazards which result in an unsound condition and which may constitute a substandard building are delineated by Section 17920.3 of the Health and Safety Code.

503.1.1 Special industrial occupancies. Buildings and structures designed to house special industrial processes that require large areas and unusual heights to accommodate craneways or special machinery and equipment, including, among others, rolling mills; structural metal fabrication shops and foundries; or the production and distribution of electric, gas or steam power, shall be exempt from the height and area limitations of Table 503.

503.1.2 Buildings on same lot. Two or more buildings on the same lot shall be regulated as separate buildings or shall be considered as portions of one building if the height of each building and the aggregate area of buildings are within the limitations of Table 503 as modified by Sections 504 and 506. The provisions of this code applicable to the aggregate building shall be applicable to each building.

503.1.3 Type I construction. Buildings of Type I construction permitted to be of unlimited tabular heights and areas are not subject to the special requirements that allow unlimited area buildings in Section 507 or unlimited height in Sections 503.1.1 and 504.3 or increased height and areas for other types of construction.

TABLE 503
ALLOWABLE HEIGHT AND BUILDING AREAS³
 Height limitations shown as stories and feet above grade plane.
 Area limitations as determined by the definition of "Area, building," per story

GROUP	HGT(feet) HGT(S)	TYPE OF CONSTRUCTION								
		TYPE I		TYPE II		TYPE III		TYPE IV	TYPE V	
		A	B	A	B	A	B	HT	A	B
		UL	160	65	55	65	55	65	50	40
A-1	S A	UL UL	5 UL	3 15,500	2 8,500	3 14,000	2 8,500	3 15,000	2 11,500	1 5,500
A-2	S A	UL UL	11 UL	3 15,500	2 9,500	3 14,000	2 9,500	3 15,000	2 11,500	1 6,000
A-3	S A	UL UL	11 UL	3 15,500	2 9,500	3 14,000	2 9,500	3 15,000	2 11,500	1 6,000
A-4	S A	UL UL	11 UL	3 15,500	2 9,500	3 14,000	2 9,500	3 15,000	2 11,500	1 6,000
A-5	S A	UL UL	UL UL	UL UL	UL UL	UL UL	UL UL	UL UL	UL UL	UL UL
B	S A	UL UL	11 UL	5 37,500	4 23,000	5 28,500	4 19,000	5 36,000	3 18,000	2 9,000
E	S A	UL UL	5 UL	3 26,500	2 14,500	3 23,500	2 14,500	3 25,500	1 18,500	1 9,500
F-1	S A	UL UL	11 UL	4 25,000	2 15,500	3 19,000	2 12,000	4 33,500	2 14,000	1 8,500
F-2	S A	UL UL	11 UL	5 37,500	3 23,000	4 28,500	3 18,000	5 50,500	3 21,000	2 13,000
H-1	S A	1 21,000	1 16,500	1 11,000	1 7,000	1 9,500	1 7,000	1 10,500	1 7,500	NP NP
H-2 ^d	S A	UL 21,000	3 16,500	2 11,000	1 7,000	2 9,500	1 7,000	2 10,500	1 7,500	1 3,000
H-3 ^d	S A	UL UL	6 60,000	4 26,500	2 14,000	4 17,500	2 13,000	4 25,500	2 10,000	1 5,000
H-4	S A	UL UL	7 UL	5 37,500	3 17,500	5 28,500	3 17,500	5 36,000	3 18,000	2 6,500
H-5	S A	4 UL	4 UL	3 37,500	3 23,000	3 28,500	3 19,000	3 36,000	3 18,000	2 9,000
I-1	S A	UL UL	5 55,000	2 19,000	NP NP	2 16,500	NP NP	NP NP	2 10,500	NP NP
I-2/I-2.1 ^f	S A	UL UL	4 UL	2 15,000	1 11,000	1 12,000	NP NP	1 12,000	1 9,500	NP NP
I-3 ^e	S A	UL UL	2 15,100	NP NP	NP NP	NP NP	NP NP	NP NP	NP NP	NP NP
I-4	S A	UL UL	5 60,500	3 26,500	2 13,000	3 23,500	2 13,000	3 25,500	1 18,500	1 9,000
L	S A	UL UL	6 60,000	5 37,500	3 17,500	5 28,500	3 17,500	5 36,000	3 18,000	2 6,500
M	S A	UL UL	11 UL	4 21,500	4 12,500	4 18,500	4 12,500	4 20,500	3 14,000	1 9,000
R-1	S A	UL UL	11 UL	4 24,000	4 16,000	4 24,000	4 16,000	4 20,500	3 12,000	2 7,000
R-2	S A	UL UL	11 UL	4 24,000	4 16,000	4 24,000	4 16,000	4 20,500	3 12,000	2 7,000
R-3/R-3.1	S A	UL UL	11 UL	4 UL	4 UL	4 UL	4 UL	4 UL	3 UL	3 UL
R-4	S A	UL UL	11 UL	4 24,000	4 16,000	4 24,000	4 16,000	4 20,500	3 12,000	2 7,000
S-1	S A	UL UL	11 48,000	4 26,000	3 17,500	3 26,000	3 17,500	4 25,500	3 14,000	1 9,000
S-2 ^{b,c}	S A	UL UL	11 79,000	5 39,000	4 26,000	4 39,000	4 26,000	5 38,500	4 21,000	2 13,500

(continued)

TABLE 503—continued
ALLOWABLE HEIGHT AND BUILDING AREAS^a
 Height limitations shown as stories and feet above grade plane.
 Area limitations as determined by the definition of “Area, building,” per story

GROUP	HGT(feet) HGT(S)	TYPE OF CONSTRUCTION								
		TYPE I		TYPE II		TYPE III		TYPE IV	TYPE V	
		A	B	A	B	A	B	HT	A	B
		UL	160	65	55	65	55	65	50	40
U ^c	S A	UL UL	5 35,500	4 19,000	2 8,500	3 14,000	2 8,500	4 18,000	2 9,000	1 5,500

For SI: 1 foot = 304.8 mm, 1 square foot = 0.0929m².

UL = Unlimited, NP = Not permitted.

- a. See the following sections for general exceptions to Table 503:
 1. Section 504.2, Allowable height increase due to automatic sprinkler system installation.
 2. Section 506.2, Allowable area increase due to street frontage.
 3. Section 506.3, Allowable area increase due to automatic sprinkler system installation.
 4. Section 507, Unlimited area buildings.
- b. For open parking structures, see Section 406.3.
- c. For private garages, see Section 406.1.
- d. See Section 415.5 for limitations.
- e. [SFM] See Section 408.1.1 for specific exceptions for one-story Type IIA, IIIA or VA construction.
- f. Restraint shall not be permitted in any building except in Group I-3 occupancies constructed for such use (see Section 308.4).

**SECTION 504
 HEIGHT**

504.1 General. The height permitted by Table 503 shall be increased in accordance with this section.

Exception: The height of one-story aircraft hangars, aircraft paint hangars and buildings used for the manufacturing of aircraft shall not be limited if the building is provided with an automatic fire-extinguishing system in accordance with Chapter 9 and is entirely surrounded by public ways or yards not less in width than one and one-half times the height of the building.

504.2 Automatic sprinkler system increase. Where a building is equipped throughout with an approved automatic sprinkler system in accordance with Section 903.3.1.1, the value specified in Table 503 for maximum height is increased by 20 feet (6096 mm) and the maximum number of stories is increased by one. Increases are permitted in addition to the area increase in accordance with Section 506.2. *In other than high-rise buildings, Group A, E, H, I, L and R occupancies and other applications listed in Section 111 regulated by the Office of the State Fire Marshal, these increases are permitted in addition to the area increase in accordance with Section 506.3.* For Group R -2 buildings of Type VA construction equipped throughout with an approved automatic sprinkler system in accordance with Section 903.3.1.1, the value specified in Table 503 for maximum height is increased by 20 feet (6096 mm) and the maximum number of stories is increased by one, but shall not exceed 60 feet (18 288 mm) or four stories, respectively, *these increases are permitted in addition to the area increase in accordance with Section 506.3.*

Exceptions:

- 1. Fire areas with an occupancy in Group I-2 of Type IIB, III, IV or V construction.

- 2. Fire areas with an occupancy in Group H-1, H-2, H-3 or H-5.
- 3. Fire-resistance rating substitution in accordance with Table 601, Note e.
- 4. [SFM] Fire areas with an occupancy in Group L.
- 5. [SFM] Fire areas with an occupancy in licensed Group I-1 and R-4.

504.3 Roof structures. Towers, spires, steeples and other roof structures shall be constructed of materials consistent with the required type of construction of the building except where other construction is permitted by Section 1509.2.1. Such structures shall not be used for habitation or storage. The structures shall be unlimited in height if of noncombustible materials and shall not extend more than 20 feet (6096 mm) above the allowable height if of combustible materials (see Chapter 15 for additional requirements).

**SECTION 505
 MEZZANINES**

505.1 General. A mezzanine or mezzanines in compliance with Section 505 shall be considered a portion of the story below. Such mezzanines shall not contribute to either the building area or number of stories as regulated by Section 503.1. The area of the mezzanine shall be included in determining the fire area defined in Section 702. The clear height above and below the mezzanine floor construction shall not be less than 7 feet (2134 mm).

505.2 Area limitation. The aggregate area of a mezzanine or mezzanines within a room shall not exceed one-third of the floor area of that room or space in which they are located. The enclosed portion of a room shall not be included in a determination of the floor area of the room in which the mezzanine is located. In determining the allowable mezzanine area, the area

of the mezzanine shall not be included in the floor area of the room.

Exceptions:

1. The aggregate area of mezzanines in buildings and structures of Type I or II construction for special industrial occupancies in accordance with Section 503.1.1 shall not exceed two-thirds of the floor area of the room.
2. The aggregate area of mezzanines in buildings and structures of Type I or II construction shall not exceed one-half of the floor area of the room in buildings and structures equipped throughout with an approved automatic sprinkler system in accordance with Section 903.3.1.1 and an approved emergency voice/alarm communication system in accordance with Section 907.2.12.2.

505.3 Egress. Each occupant of a mezzanine shall have access to at least two independent means of egress where the common path of egress travel exceeds the limitations of Section 1014.3. Where a stairway provides a means of exit access from a mezzanine, the maximum travel distance includes the distance traveled on the stairway measured in the plane of the tread nosing. Accessible means of egress shall be provided in accordance with Section 1007.

Exception: A single means of egress shall be permitted in accordance with Section 1015.1.

505.4 Openness. A mezzanine shall be open and unobstructed to the room in which such mezzanine is located except for walls not more than 42 inches (1067 mm) high, columns and posts.

Exceptions:

1. Mezzanines or portions thereof are not required to be open to the room in which the mezzanines are located, provided that the occupant load of the aggregate area of the enclosed space does not exceed 10.
2. A mezzanine having two or more means of egress is not required to be open to the room in which the mezzanine is located if at least one of the means of egress provides direct access to an exit from the mezzanine level.
3. Mezzanines or portions thereof are not required to be open to the room in which the mezzanines are located, provided that the aggregate floor area of the enclosed space does not exceed 10 percent of the mezzanine area.
4. In industrial facilities, mezzanines used for control equipment are permitted to be glazed on all sides.
5. In other than Groups H and I occupancies no more than two stories in height above grade plane and equipped throughout with an automatic sprinkler system in accordance with Section 903.3.1.1, a mezzanine having two or more means of egress shall not be required to be open to the room in which the mezzanine is located.

505.5 Equipment platforms. Equipment platforms in buildings shall not be considered as a portion of the floor below. Such equipment platforms shall not contribute to either the

building area or the number of stories as regulated by Section 503.1. The area of the equipment platform shall not be included in determining the fire area. Equipment platforms shall not be a part of any mezzanine and such platforms and the walkways, stairs and ladders providing access to an equipment platform shall not serve as a part of the means of egress from the building.

505.5.1 Area limitations. The aggregate area of all equipment platforms within a room shall not exceed two-thirds of the area of the room in which they are located. Where an equipment platform is located in the same room as a mezzanine, the area of the mezzanine shall be determined by Section 505.2 and the combined aggregate area of the equipment platforms and mezzanines shall not exceed two-thirds of the room in which they are located.

[F] 505.5.2 Fire suppression. Where located in a building that is required to be protected by an automatic sprinkler system, equipment platforms shall be fully protected by sprinklers above and below the platform, where required by the standards referenced in Section 903.3.

505.5.3 Guards. Equipment platforms shall have guards where required by Section 1013.1.

**SECTION 506
AREA MODIFICATIONS**

506.1 General. The areas limited by Table 503 shall be permitted to be increased due to frontage (I_f) and automatic sprinkler system protection (I_s) in accordance with the following:

$$A_a = \{ A_t + [A_t \times I_f] + [A_t \times I_s] \} \quad \text{(Equation 5-1)}$$

where:

A_a = Allowable area per story (square feet).

A_t = Tabular area per story in accordance with Table 503 (square feet).

I_f = Area increase factor due to frontage as calculated in accordance with Section 506.2.

I_s = Area increase factor due to sprinkler protection as calculated in accordance with Section 506.3.

506.1.1 Basements. A single basement that is not a story above grade plane need not be included in the total allowable area, provided such basement does not exceed the area permitted for a building with no more than one story above grade plane.

506.2 Frontage increase. Every building shall adjoin or have access to a public way to receive an area increase for frontage. Where a building has more than 25 percent of its perimeter on a public way or open space having a minimum width of 20 feet (6096 mm), the frontage increase shall be determined in accordance with the following:

$$I_f = [F/P - 0.25]W / 30 \quad \text{(Equation 5-2)}$$

where:

I_f = Area increase due to frontage.

SECTION 508 MIXED USE AND OCCUPANCY

508.1 General. Where a building or portion thereof contains two or more occupancies or uses, the building or portion thereof shall comply with the applicable provisions of this section.

508.2 Incidental uses. Incidental use areas shall comply with the provisions of this section.

Exception: Incidental use areas within and serving a dwelling unit are not required to comply with this section.

508.2.1 Occupancy classification. An incidental use area shall be classified in accordance with the occupancy of that portion of the building in which it is located or the building shall be classified as a mixed occupancy and shall comply with Section 508.3.

508.2.2 Separation. Incidental use areas shall be separated or protected, or both, in accordance with Table 508.2.

508.2.2.1 Construction. Where Table 508.2 requires a fire-resistance-rated separation, the incidental use area shall be separated from the remainder of the building by a fire barrier constructed in accordance with Section 706 or a horizontal assembly constructed in accordance with Section 711, or both. Where Table 508.2 permits an automatic fire-extinguishing system without a fire barrier, the incidental use area shall be separated from the remainder of the building by construction capable of resisting the passage of smoke. The partitions shall extend from the floor to the underside of the fire-resistance-rated floor/ceiling assembly or fire-resistance-rated roof/ceiling assembly above or to the underside of the floor or roof sheathing, or sub deck above. Doors shall be self- or automatic closing upon detection of smoke in accordance with Section 715.4.7.3. Doors shall not have air transfer openings and shall not be undercut in excess of the clearance permitted in accordance with NFPA 80.

508.2.3 Protection. Where an automatic fire-extinguishing system or an automatic sprinkler system is provided in accordance with Table 508.2, only the incidental use areas need be equipped with such a system.

508.3 Mixed occupancies. Each portion of a building shall be individually classified in accordance with Section 302.1.

Where a building contains more than one occupancy group, the building or portion thereof shall comply with Sections 508.3.1, 508.3.2, 508.3.3 or a combination of these sections.

Exceptions:

1. Occupancies separated in accordance with Section 509.
2. Where required by Table 415.3.2, areas of Group H-1, H-2 or H-3 occupancies shall be located in a separate and detached building or structure.

508.3.1 Accessory occupancies. Accessory occupancies are those occupancies subsidiary to the main occupancy of the building or portion thereof. Aggregate accessory occu-

pancies shall not occupy more than 10 percent of the area of the story in which they are located and shall not exceed the tabular values in Table 503, without height and area increases in accordance with Sections 504 and 506 for such accessory occupancies.

Exceptions:

1. Accessory assembly areas having a floor area less than 750 square feet (69.7 m²) are not considered separate occupancies.
2. Assembly areas that are accessory to Group E occupancies are not considered separate occupancies except when applying the assembly occupancy requirements of *Chapter 11B*.
3. Accessory religious educational rooms and religious auditoriums with occupant loads of less than 100 are not considered separate occupancies.

508.3.1.1 Occupancy classification. Accessory occupancies shall be individually classified in accordance with Section 302.1. Code requirements shall apply to each portion of the building based on the occupancy classification of that accessory space, except that the most restrictive applicable provisions of Section 403 and Chapter 9 shall apply to the entire building or portion thereof.

508.3.1.2 Allowable area and height. The allowable area and height of the building shall be based on the allowable area and height for the main occupancy in accordance with Section 503.1. The height of any accessory occupancy shall not exceed the tabular values in Table 503, without height and area increases in accordance with Sections 504 and 506 for such accessory occupancies.

508.3.1.3 Separation. No separation is required between accessory occupancies or the main occupancy.

Exception: Group H-2, H-3, H-4, H-5, I-2, I-2.1 or I-3 occupancies shall be separated from all other occupancies in accordance with Section 508.3.3.

508.3.2 Nonseparated occupancies. Buildings or portions of buildings that comply with the provisions of this section shall qualify as nonseparated occupancies.

508.3.2.1 Occupancy classification. Nonseparated occupancies shall be individually classified in accordance with Section 302.1. Code requirements shall apply to each portion of the building based on the occupancy classification of that space except that the most restrictive applicable provisions of Section 403 and Chapter 9 shall apply to the entire building or portion thereof.

508.3.2.2 Allowable area and height. The allowable area and height of the building or portion thereof shall be based on the most restrictive allowances for the occupancy groups under consideration for the type of construction of the building in accordance with Section 503.1.

**TABLE 508.2
INCIDENTAL USE AREAS**

ROOM OR AREA	SEPARATION AND/OR PROTECTION
Furnace room where any piece of equipment is over 400,000 Btu per hour input	1 hour or provide automatic fire-extinguishing system ^a
Rooms with boilers where the largest piece of equipment is over 15 psi and 10 horsepower	1 hour or provide automatic fire-extinguishing system ^a
Refrigerant machinery rooms	1 hour or provide automatic sprinkler system ^a
Parking garage (Section 406.2)	2 hours; or 1 hour and provide automatic fire-extinguishing system
Hydrogen cut-off rooms, not classified as Group H	1-hour in Group B, F, M, S and U occupancies. 2-hour in Group A, E, I and R occupancies.
Incinerator rooms	2 hours and automatic sprinkler system
Paint shops, not classified as Group H, located in occupancies other than Group F	2 hours; or 1 hour and provide automatic fire-extinguishing system
Laboratories and vocational shops, not classified as Group H, located in Group I-2 and I-2.1 occupancies	1 hour or provide automatic fire-extinguishing system ^a
[SFM] Rooms or areas with special hazards such as laboratories, vocational shops and other such areas not classified as Group H, located in Group E occupancies where hazardous materials in exempt amounts are used or stored	1 hour
Laundry rooms over 100 square feet	1 hour or provide automatic fire-extinguishing system ^a
Storage rooms over 100 square feet	1 hour or provide automatic fire-extinguishing system ^a
Group I-2 and I-2.1 waste and linen collection rooms	1 hour ^a
Waste and linen collection rooms over 100 square feet	1 hour or provide automatic fire-extinguishing system ^a
Stationary storage battery systems having a liquid capacity of more than 100 gallons used for facility standby power, emergency power or uninterrupted power supplies	1-hour in Group B, F, M, S and U occupancies. 2-hour in Group A, E, I and R occupancies ^a .

For SI: 1 square foot = 0.0929m², 1 pound per square inch = 6.9 kPa, 1 British thermal unit per hour = 0.293 watts, 1 horsepower = 746 watts, 1 gallon = 3.785 L.

a. [SFM] Fire barrier protection and automatic sprinkler protection required throughout the fire area in I-2 and I-2.1 occupancies as indicated.

508.3.2.3 Separation. No separation is required between occupancies.

Exception: Group H-2, H-3, H-4, H-5, I-2, I-2.1, I-3 or L occupancies shall be separated from all other occupancies in accordance with Section 508.3.3.

508.3.3 Separated occupancies. Buildings or portions of buildings that comply with the provisions of this section shall qualify as separated occupancies.

508.3.3.1 Occupancy classification. Separated occupancies shall be individually classified in accordance with Section 302.1. Each fire area shall comply with this code based on the occupancy classification of that portion of the building.

508.3.3.2 Allowable area. In each story, the building area shall be such that the sum of the ratios of the actual floor area of each occupancy divided by the allowable area of each occupancy shall not exceed one.

508.3.3.3 Allowable height. Each occupancy shall comply with the height limitations based on the type of construction of the building in accordance with Section 503.1. The height, in both feet and stories, of each fire area shall be measured from grade plane. This measurement shall include the height, in both feet and stories, of intervening fire areas.

Exception: Special provisions permitted by Section 509.

508.3.3.4 Separation. Individual occupancies shall be separated from adjacent occupancies in accordance with Table 508.3.3.

508.3.3.4.1 Construction. Required separations shall be fire barriers constructed in accordance with Section 706 or horizontal assemblies constructed in accordance with Section 711, or both, so as to completely separate adjacent occupancies.

**SECTION 509
SPECIAL PROVISIONS**

509.1 General. The provisions in this section shall permit the use of special conditions that are exempt from, or modify, the specific requirements of this chapter regarding the allowable heights and areas of buildings based on the occupancy classification and type of construction, provided the special condition complies with the provisions specified in this section for such condition and other applicable requirements of this code.

509.2 Group S-2 enclosed or open parking garage with Group A, B, I-1, M, R or S above. A basement and/or the first story above grade plane of a building shall be considered as a separate and distinct building for the purpose of determining area limitations, continuity of fire walls, limitation of number of stories and type of construction when all of the following conditions are met:

1. The basement and/or the first story above grade plane is of Type IA construction and is separated from the build-

603.1.2 Piping. The use of combustible piping materials shall be permitted when installed in accordance with the limitations of the *California Mechanical Code* and the *California Plumbing Code*.

603.1.3 Electrical. The use of electrical wiring methods with combustible insulation, tubing, raceways and related components shall be permitted when installed in accordance with the limitations of the *California Electrical Code*.

**TABLE 601
FIRE-RESISTANCE RATING REQUIREMENTS FOR BUILDING ELEMENTS (hours)**

BUILDING ELEMENT	TYPE I		TYPE II		TYPE III		TYPE IV	TYPE V	
	A	B	A ^e	B	A ^e	B	HT	A ^e	B
Structural frame ^a	3 ^b	2 ^b	1	0	1	0	HT	1	0
Bearing walls									
Exterior ^g	3	2	1	0	2	2	2	1	0
Interior	3 ^b	2 ^b	1	0	1	0	1/HT	1	0
Nonbearing walls and partitions Exterior	See Table 602								
Nonbearing walls and partitions Interior ^f	0	0	0	0	0	0	See Section 602.4.6	0	0
Floor construction Including supporting beams and joists	2	2	1	0	1	0	HT	1	0
Roof construction Including supporting beams and joists	1 1/2 ^c	1 ^{c, d}	1 ^{c, d}	0 ^d	1 ^{c, d}	0 ^d	HT	1 ^{c, d}	0

For SI: 1 foot = 304.8 mm.

- a. The structural frame shall be considered to be the columns and the girders, beams, trusses and spandrels having direct connections to the columns and bracing members designed to carry gravity loads. The members of floor or roof panels which have no connection to the columns shall be considered secondary members and not a part of the structural frame.
- b. Roof supports: Fire-resistance ratings of structural frame and bearing walls are permitted to be reduced by 1 hour where supporting a roof only.
- c1. Except in *high-rise buildings*, Group A, E, F-1, H, I, L, M, R-1, R-2 and S-1 occupancies, fire protection of structural members shall not be required, including protection of roof framing and decking where every part of the roof construction is 20 feet or more above any floor immediately below. Fire-retardant-treated wood members shall be allowed to be used for such unprotected members.
- c2. For *high-rise buildings*, Group A, E, I, L, R-1 and R-2 occupancies and other applications listed in Section 111 regulated by the Office of the State Fire Marshal, fire protection of members other than the structural frame shall not be required, including protection of roof framing and decking where every part of the roof construction is 20 feet or more above any floor immediately below. Fire-retardant-treated wood members shall be allowed to be used for such unprotected members.
- c3. *One-story portions of Group A and E assembly occupancies the roof-framing system of Type II A or Type III A construction may be of unprotected construction when such roof-framing system is open to the assembly area and does not contain concealed spaces.*
- d. In all occupancies, heavy timber shall be allowed where a 1-hour or less fire-resistance rating is required.
- e. An approved automatic sprinkler system in accordance with Section 903.3.1.1 shall be allowed to be substituted for 1-hour fire-resistance-rated construction, provided such system is not otherwise required by other provisions of the code or used for an allowable area increase in accordance with Section 506.3 or an allowable height increase in accordance with Section 504.2. The 1-hour substitution for the fire resistance of exterior walls shall not be permitted.
- f. Not less than the fire-resistance rating required by other sections of this code.
- g. Not less than the fire-resistance rating based on fire separation distance (see Table 602).

TYPES OF CONSTRUCTION

**TABLE 602
FIRE-RESISTANCE RATING REQUIREMENTS FOR EXTERIOR WALLS BASED ON FIRE SEPARATION DISTANCE^{a,e}**

FIRE SEPARATION DISTANCE = X (feet)	TYPE OF CONSTRUCTION	OCCUPANCY GROUP H, L	OCCUPANCY GROUP F-1, M, S-1	OCCUPANCY GROUP A, B, E, F-2, I, F ^f , S-2, U ^{b,f}
$x < 5^c$	All	3	2	1
$5 \leq x < 10$	IA Others	3 2	2 1	1 1
$10 \leq x < 30$	IA, IB IIB, VB Others	2 1 1	1 0 1	1 ^d 0 1 ^d
$X \geq 30$	All	0	0	0

For SI: 1 foot = 304.8 mm.

a. Load-bearing exterior walls shall also comply with the fire-resistance rating requirements of Table 601.

b. For special requirements for Group U occupancies see Section 406.1.2

c. See Section 705.1.1 for party walls.

d. Open parking garages complying with Section 406 shall not be required to have a fire-resistance rating.

e. The fire-resistance rating of an exterior wall is determined based upon the fire separation distance of the exterior wall and the story in which the wall is located.

f. Group R-3, and Group U when used as accessory to Group R-3, shall not be required to have a fire-resistance rating where the fire separation distance is 5 feet or more.

**TABLE 602.4
WOOD MEMBER SIZE**

MINIMUM NOMINAL SOLID SAWN SIZE		MINIMUM GLUED-LAMINATED NET SIZE	
Width, inch	Depth, inch	Width, inch	Depth, inch
8	8	6 ³ / ₄	8 ¹ / ₄
6	10	5	10 ¹ / ₂
6	8	5	8 ¹ / ₄
6	6	5	6
4	6	3	6 ⁷ / ₈

For SI: 1 inch = 25.4 mm.

**CALIFORNIA BUILDING CODE – MATRIX ADOPTION TABLE
CHAPTER 7 – FIRE RESISTANCE-RATED CONSTRUCTION**

Adopting Agency	BSC	SFM	HCD			DSA		OSHDPD				CSA	DHS	AGR	DWR	CEC	CA	SL	SLC
			1	2	1/AC	AC	SS	1	2	3	4								
Adopt Entire Chapter	X					X ◆	X ◆	X	X	X	X								
Adopt Entire Chapter as amended (amended sections listed below)		X	X ◆	X ◆															
Adopt only those sections that are listed below																			
Chapter / Section	Codes																		
704.5	CA		X																
Table 705.4	CA		X																
Table 706.3.9	CA		X																
707.2	CA		X																
707.2	IBC			X	X														
707.14.1	CA		X																
708.1	CA		X																
708.3	IBC																		
708.4	IBC			X	X														
708.8	IBC			X	X														
709.5	CA		X																
710.2	CA		X																
710.7	CA		X																
715.4.3	CA		X																
715.4.5.1	CA		X																
715.4.7.3	CA		X																
716.5.2	CA		X																
716.5.4	CA		X						X	X	X	X							
716.5.4	IBC			X	X														
716.5.4.1	CA		X																
717.3.3	CA		X																
717.4.3	CA		X																
720.2.5	CA			X	X														
720.2.5.1	CA			X	X														

<
||

The ◆ designation indicates that the Office of the State Fire Marshal’s adoption of this chapter or individual sections is applicable to structures subject to HCD 1 and/or HCD 2 or DSA-SS.

**TABLE 704.8
MAXIMUM AREA OF EXTERIOR WALL OPENINGS^a**

CLASSIFICATION OF OPENING	FIRE SEPARATION DISTANCE (feet)							
	0 to 3 ^{f,j}	Greater than 3 to 5 ^{c,g}	Greater than 5 to 10 ^{c,e,g,h}	Greater than 10 to 15 ^{d,e,g}	Greater than 15 to 20 ^{d,g}	Greater than 20 to 25 ^{d,g}	Greater than 25 to 30 ^{d,g}	Greater than 30
Unprotected	Not Permitted	Not Permitted ^c	10% ⁱ	15% ⁱ	25% ⁱ	45% ⁱ	70% ⁱ	No Limit ^b
Protected	Not Permitted	15%	25%	45%	75%	No Limit ^b	No Limit ^b	No Limit ^b

For SI: 1 foot = 304.8 mm.

a. Values given are percentage of the area of the exterior wall.

b. Not used

c. For occupancies in Group R-3, the maximum percentage of unprotected and protected exterior wall openings shall be 25 percent.

d. The area of openings in an open parking structure with a fire separation distance of greater than 10 feet shall not be limited.

e. For occupancies in Group H-2 or H-3, unprotected openings shall not be permitted for openings with a fire separation distance of 15 feet or less.

f. For requirements for fire walls for buildings with differing roof heights, see Section 705.6.1.

g. The area of unprotected and protected openings is not limited for occupancies in Group R-3, with a fire separation distance greater than 5 feet.

h. For special requirements for Group U occupancies, see Section 406.1.2.

i. Buildings whose exterior bearing wall, exterior nonbearing wall and exterior structural frame are not required to be fire-resistance rated by Table 601 or 602 shall be permitted to have unlimited unprotected openings.

j. Includes accessory buildings to Group R-3.

704.8.1 Automatic sprinkler system. In buildings equipped throughout with an automatic sprinkler system in accordance with Section 903.3.1.1, the maximum allowable area of unprotected openings in occupancies other than Groups H-1, H-2 and H-3 shall be the same as the tabulated limitations for protected openings.

704.8.2 First story. In occupancies other than Group H, unlimited unprotected openings are permitted in the exterior walls of the first story above grade facing a street that have a fire separation distance of greater than 15 feet (4572 mm) or facing an unoccupied space. The unoccupied space shall be on the same lot or dedicated for public use, shall not be less than 30 feet (9144 mm) in width and shall have access from a street by a posted fire lane in accordance with the *California Fire Code*.

704.9 Vertical separation of openings. Openings in exterior walls in adjacent stories shall be separated vertically to protect against fire spread on the exterior of the buildings where the openings are within 5 feet (1524 mm) of each other horizontally and the opening in the lower story is not a protected opening with a fire protection rating of not less than 3/4 hour. Such openings shall be separated vertically at least 3 feet (914 mm) by spandrel girders, exterior walls or other similar assemblies that have a fire-resistance rating of at least 1 hour or by flame barriers that extend horizontally at least 30 inches (762 mm) beyond the exterior wall. Flame barriers shall also have a fire-resistance rating of at least 1 hour. The unexposed surface temperature limitations specified in ASTM E 119 shall not apply to the flame barriers or vertical separation unless otherwise required by the provisions of this code.

Exceptions:

1. This section shall not apply to buildings that are three stories or less in height.
2. This section shall not apply to buildings equipped throughout with an automatic sprinkler system in accordance with Section 903.3.1.1 or 903.3.1.2.
3. Open parking garages.

704.10 Vertical exposure. For buildings on the same lot, opening protectives having a fire-protection rating of not less than 3/4 hour shall be provided in every opening that is less than 15 feet (4572 mm) vertically above the roof of an adjoining building or adjacent structure that is within a horizontal fire separation distance of 15 feet (4572 mm) of the wall in which the opening is located.

Exception: Opening protectives are not required where the roof construction has a fire-resistance rating of not less than 1 hour for a minimum distance of 10 feet (3048 mm) from the adjoining building, and the entire length and span of the supporting elements for the fire-resistance-rated roof assembly has a fire-resistance rating of not less than 1 hour.

704.11 Parapets. Parapets shall be provided on exterior walls of buildings.

Exceptions: A parapet need not be provided on an exterior wall where any of the following conditions exist:

1. The wall is not required to be fire-resistance rated in accordance with Table 602 because of fire separation distance.
2. The building has an area of not more than 1,000 square feet (93 m²) on any floor.
3. Walls that terminate at roofs of not less than 2-hour fire-resistance-rated construction or where the roof, including the deck or slab and supporting construction, is constructed entirely of noncombustible materials.
4. One-hour fire-resistance-rated exterior walls that terminate at the underside of the roof sheathing, deck or slab, provided:
 - 4.1. Where the roof/ceiling framing elements are parallel to the walls, such framing and elements supporting such framing shall not be of less than 1-hour fire-resistance-rated construction for a width of 4 feet (1220 mm) for Groups R and U and 10 feet (3048 mm) for

other occupancies, measured from the interior side of the wall.

- 4.2. Where roof/ceiling framing elements are not parallel to the wall, the entire span of such framing and elements supporting such framing shall not be of less than 1-hour fire-resistance-rated construction.
- 4.3. Openings in the roof shall not be located within 5 feet (1524 mm) of the 1-hour fire-resistance-rated exterior wall for Groups R and U and 10 feet (3048 mm) for other occupancies, measured from the interior side of the wall.
- 4.4. The entire building shall be provided with not less than a Class B roof covering.
5. In Groups R-2 and R-3 where the entire building is provided with a Class C roof covering, the exterior wall shall be permitted to terminate at the underside of the roof sheathing or deck in Type III, IV and V construction, provided:
 - 5.1. The roof sheathing or deck is constructed of approved noncombustible materials or of fire-retardant-treated wood for a distance of 4 feet (1220 mm); or
 - 5.2. The roof is protected with 0.625-inch (16 mm) Type X gypsum board directly beneath the underside of the roof sheathing or deck, supported by a minimum of nominal 2-inch (51 mm) ledgers attached to the sides of the roof framing members for a minimum distance of 4 feet (1220 mm).
6. Where the wall is permitted to have at least 25 percent of the exterior wall areas containing unprotected openings based on fire separation distance as determined in accordance with Section 704.8.

704.11.1 Parapet construction. Parapets shall have the same fire-resistance rating as that required for the supporting wall, and on any side adjacent to a roof surface, shall have noncombustible faces for the uppermost 18 inches (457 mm), including counterflashing and coping materials. The height of the parapet shall not be less than 30 inches (762 mm) above the point where the roof surface and the wall intersect. Where the roof slopes toward a parapet at a slope greater than two units vertical in 12 units horizontal (16.7-percent slope), the parapet shall extend to the same height as any portion of the roof within a fire separation distance where protection of wall openings is required, but in no case shall the height be less than 30 inches (762 mm).

704.12 Opening protection. Windows in exterior walls required to have protected openings in accordance with other sections of this code or determined to be protected in accordance with Section 704.3 or 704.8 shall comply with Section 715.5. Other openings required to be protected with fire door or shutter assemblies in accordance with other sections of this

code or determined to be protected in accordance with Section 704.3 or 704.8 shall comply with Section 715.4.

Exception: Opening protectives are not required where the building is protected throughout by an automatic sprinkler system and the exterior openings are protected by an approved water curtain using automatic sprinklers approved for that use. The sprinklers and the water curtain shall be installed in accordance with Section 903.3.1.1 and shall have an automatic water supply and fire department connection.

704.12.1 Unprotected openings. Where protected openings are not required by Section 704, windows and doors shall be constructed of any approved materials. Glazing shall conform to the requirements of Chapters 24 and 26.

704.13 Joints. Joints made in or between exterior walls required by this section to have a fire-resistance rating shall comply with Section 713.

Exception: Joints in exterior walls that are permitted to have unprotected openings.

704.13.1 Voids. The void created at the intersection of a floor/ceiling assembly and an exterior curtain wall assembly shall be protected in accordance with Section 713.4.

704.14 Ducts and air transfer openings. Penetrations by air ducts and air transfer openings in fire-resistance-rated exterior walls required to have protected openings shall comply with Section 716.

Exception: Foundation vents installed in accordance with this code are permitted.

SECTION 705 FIRE WALLS

705.1 General. Each portion of a building separated by one or more fire walls that comply with the provisions of this section shall be considered a separate building. The extent and location of such fire walls shall provide a complete separation. Where a fire wall also separates occupancies that are required to be separated by a fire barrier wall, the most restrictive requirements of each separation shall apply.

705.1.1 Party walls. Any wall located on a lot line between adjacent buildings, which is used or adapted for joint service between the two buildings, shall be constructed as a fire wall in accordance with Section 705. Party walls shall be constructed without openings and shall create separate buildings.

705.2 Structural stability. Fire walls shall have sufficient structural stability under fire conditions to allow collapse of construction on either side without collapse of the wall for the duration of time indicated by the required fire-resistance rating.

705.3 Materials. Fire walls shall be of any approved noncombustible materials.

Exception: Buildings of Type V construction.

705.4 Fire-resistance rating. Fire walls shall have a fire-resistance rating of not less than that required by Table 705.4.

**TABLE 705.4
FIRE WALL FIRE-RESISTANCE RATINGS**

GROUP	FIRE-RESISTANCE RATING (hours)
A, B, E, H-4, I, R-1, R-2, U, L	3 ^a
F-1, H-3 ^b , H-5, M, S-1	3
H-1, H-2	4 ^b
F-2, S-2, R-3, R-4	2

- a. Walls shall be not less than 2-hour fire-resistance rated where separating buildings of Type II or V construction.
- b. For Group H-1, H-2 or H-3 buildings, also see Sections 415.4 and 415.5.

705.5 Horizontal continuity. Fire walls shall be continuous from exterior wall to exterior wall and shall extend at least 18 inches (457 mm) beyond the exterior surface of exterior walls.

Exceptions:

1. Fire walls shall be permitted to terminate at the interior surface of combustible exterior sheathing or siding provided the exterior wall has a fire-resistance rating of at least 1 hour for a horizontal distance of at least 4 feet (1220 mm) on both sides of the fire wall. Openings within such exterior walls shall be protected by opening protectives having a fire protection rating of not less than 3/4 hour.
2. Fire walls shall be permitted to terminate at the interior surface of noncombustible exterior sheathing, exterior siding or other noncombustible exterior finishes provided the sheathing, siding, or other exterior noncombustible finish extends a horizontal distance of at least 4 feet (1220 mm) on both sides of the fire wall.
3. Fire walls shall be permitted to terminate at the interior surface of noncombustible exterior sheathing where the building on each side of the fire wall is protected by an automatic sprinkler system installed in accordance with Section 903.3.1.1 or 903.3.1.2.

705.5.1 Exterior walls. Where the fire wall intersects the exterior walls, the fire-resistance rating for the exterior walls on both sides of the fire wall shall have a 1-hour fire-resistance rating with 3/4-hour opening protection where opening protection is required. The fire-resistance rating of the exterior wall shall extend a minimum of 4 feet (1220 mm) on each side of the intersection of the fire wall to exterior wall. Exterior wall intersections at fire walls that form an angle equal to or greater than 180 degrees (3.14 rad) do not need exterior wall protection.

705.5.2 Horizontal projecting elements. Fire walls shall extend to the outer edge of horizontal projecting elements such as balconies, roof overhangs, canopies, marquees and

similar projections that are within 4 feet (1220 mm) of the fire wall.

Exceptions:

1. Horizontal projecting elements without concealed spaces, provided the exterior wall behind and below the projecting element has not less than 1-hour fire-resistance-rated construction for a distance not less than the depth of the projecting element on both sides of the fire wall. Openings within such exterior walls shall be protected by opening protectives having a fire protection rating of not less than 3/4 hour.
2. Noncombustible horizontal projecting elements with concealed spaces, provided a minimum 1-hour fire-resistance-rated wall extends through the concealed space. The projecting element shall be separated from the building by a minimum of 1-hour fire-resistance-rated construction for a distance on each side of the fire wall equal to the depth of the projecting element. The wall is not required to extend under the projecting element where the building exterior wall is not less than 1-hour fire-resistance rated for a distance on each side of the fire wall equal to the depth of the projecting element. Openings within such exterior walls shall be protected by opening protectives having a fire protection rating of not less than 3/4 hour.
3. For combustible horizontal projecting elements with concealed spaces, the fire wall need only extend through the concealed space to the outer edges of the projecting elements. The exterior wall behind and below the projecting element shall be of not less than 1-hour fire-resistance-rated construction for a distance not less than the depth of the projecting elements on both sides of the fire wall. Openings within such exterior walls shall be protected by opening protectives having a fire-protection rating of not less than 3/4 hour.

705.6 Vertical continuity. Fire walls shall extend from the foundation to a termination point at least 30 inches (762 mm) above both adjacent roofs.

Exceptions:

1. Stepped buildings in accordance with Section 705.6.1.
2. Two-hour fire-resistance-rated walls shall be permitted to terminate at the underside of the roof sheathing, deck or slab provided:
 - 2.1. The lower roof assembly within 4 feet (1220 mm) of the wall has not less than a 1-hour fire-resistance rating and the entire length and span of supporting elements for the rated roof

assembly has a fire-resistance rating of not less than 1 hour.

- 2.2. Openings in the roof shall not be located within 4 feet (1220 mm) of the fire wall.
- 2.3. Each building shall be provided with not less than a Class B roof covering.
3. Walls shall be permitted to terminate at the underside of noncombustible roof sheathing, deck, or slabs where both buildings are provided with not less than a Class B roof covering. Openings in the roof shall not be located within 4 feet (1220 mm) of the fire wall.
4. In buildings of Type III, IV and V construction, walls shall be permitted to terminate at the underside of combustible roof sheathing or decks provided:
 - 4.1. There are no openings in the roof within 4 feet (1220 mm) of the fire wall,
 - 4.2. The roof is covered with a minimum Class B roof covering, and
 - 4.3. The roof sheathing or deck is constructed of fire-retardant-treated wood for a distance of 4 feet (1220 mm) on both sides of the wall or the roof is protected with $\frac{5}{8}$ inch (15.9 mm) Type X gypsum board directly beneath the underside of the roof sheathing or deck, supported by a minimum of 2-inch (51 mm) nominal ledgers attached to the sides of the roof framing members for a minimum distance of 4 feet (1220 mm) on both sides of the fire wall.
5. Buildings located above a parking garage designed in accordance with Section 509.2 shall be permitted to have the fire walls for the buildings located above the parking garage extend from the horizontal separation between the parking garage and the buildings.

705.6.1 Stepped buildings. Where a fire wall serves as an exterior wall for a building and separates buildings having different roof levels, such wall shall terminate at a point not less than 30 inches (762 mm) above the lower roof level, provided the exterior wall for a height of 15 feet (4572 mm) above the lower roof is not less than 1-hour fire-resistance-rated construction from both sides with openings protected by fire assemblies having a fire protection rating of not less than $\frac{3}{4}$ hour.

Exception: Where the fire wall terminates at the underside of the roof sheathing, deck or slab of the lower roof, provided:

1. The lower roof assembly within 10 feet (3048 mm) of the wall has not less than a 1-hour fire-resistance rating and the entire length and span of supporting elements for the rated roof assembly has a fire-resistance rating of not less than 1 hour.
2. Openings in the lower roof shall not be located within 10 feet (3048 mm) of the fire wall.

705.7 Combustible framing in fire walls. Adjacent combustible members entering into a concrete or masonry fire wall from opposite sides shall not have less than a 4-inch (102 mm) distance between embedded ends. Where combustible members

frame into hollow walls or walls of hollow units, hollow spaces shall be solidly filled for the full thickness of the wall and for a distance not less than 4 inches (102 mm) above, below and between the structural members, with noncombustible materials approved for fireblocking.

705.8 Openings. Each opening through a fire wall shall be protected in accordance with Section 715.4 and shall not exceed 120 square feet (11 m²). The aggregate width of openings at any floor level shall not exceed 25 percent of the length of the wall.

Exceptions:

1. Openings are not permitted in party walls constructed in accordance with Section 705.1.1.
2. Openings shall not be limited to 120 square feet (11 m²) where both buildings are equipped throughout with an automatic sprinkler system installed in accordance with Section 903.3.1.1.

705.9 Penetrations. Penetrations of fire walls shall comply with Section 712.

705.10 Joints. Joints made in or between fire walls shall comply with Section 713.

705.11 Ducts and air transfer openings. Ducts and air transfer openings shall not penetrate fire walls.

Exception: Penetrations by ducts and air transfer openings of fire walls that are not on a lot line shall be allowed provided the penetrations comply with Sections 712 and 716. The size and aggregate width of all openings shall not exceed the limitations of Section 705.8.

**SECTION 706
FIRE BARRIERS**

706.1 General. Fire barriers installed as required elsewhere in this code or the *California Fire Code* shall comply with this section.

706.2 Materials. Fire barriers shall be of materials permitted by the building type of construction.

706.2.1 Fire-resistance-rated glazing. Fire-resistance-rated glazing, when tested in accordance with ASTM E 119 and complying with the requirements of Section 706, shall be permitted. Fire-resistance-rated glazing shall bear a label or other identification showing the name of the manufacturer, the test standard and the identifier “W-XXX,” where the “XXX” is the fire-resistance rating in minutes. Such label or identification shall be issued by an approved agency and shall be permanently affixed to the glazing.

706.3 Fire-resistance rating. The fire-resistance rating of fire barriers shall comply with this section.

706.3.1 Shaft enclosures. The fire-resistance rating of the fire barrier separating building areas from a shaft shall comply with Section 707.4.

706.3.2 Exit enclosures. The fire-resistance rating of the fire barrier separating building areas from an exit shall comply with Section 1020.1.

requirements of Section 704 for exterior walls and the fire-resistance-rated enclosure requirements shall not apply.

Exception: Exterior walls required to be fire-resistance rated in accordance with Section 1014.5.1 for exterior egress balconies, Section 1020.1.4 for exit enclosures and Section 1023.6 for exterior exit ramps and stairways.

707.7 Openings. Openings in a shaft enclosure shall be protected in accordance with Section 715 as required for fire barriers. Doors shall be self- or automatic closing by smoke detection in accordance with Section 715.4.7.3.

707.7.1 Prohibited openings. Openings other than those necessary for the purpose of the shaft shall not be permitted in shaft enclosures.

707.8 Penetrations. Penetrations in a shaft enclosure shall be protected in accordance with Section 712 as required for fire barriers.

707.8.1 Prohibited penetrations. Penetrations other than those necessary for the purpose of the shaft shall not be permitted in shaft enclosures.

707.9 Joints. Joints in a shaft enclosure shall comply with Section 713.

707.10 Ducts and air transfer openings. Penetrations of a shaft enclosure by ducts and air transfer openings shall comply with Section 716.

707.11 Enclosure at the bottom. Shafts that do not extend to the bottom of the building or structure shall:

1. Be enclosed at the lowest level with construction of the same fire-resistance rating as the lowest floor through which the shaft passes, but not less than the rating required for the shaft enclosure;
2. Terminate in a room having a use related to the purpose of the shaft. The room shall be separated from the remainder of the building by a fire barrier having a fire-resistance rating and opening protectives at least equal to the protection required for the shaft enclosure; or
3. Be protected by approved fire dampers installed in accordance with their listing at the lowest floor level within the shaft enclosure.

Exceptions:

1. The fire-resistance-rated room separation is not required, provided there are no openings in or penetrations of the shaft enclosure to the interior of the building except at the bottom. The bottom of the shaft shall be closed off around the penetrating items with materials permitted by Section 717.3.1 for draftstopping, or the room shall be provided with an approved automatic fire suppression system.
2. A shaft enclosure containing a refuse chute or laundry chute shall not be used for any other purpose and shall terminate in a room protected in accordance with Section 707.13.4.
3. The fire-resistance-rated room separation and the protection at the bottom of the shaft are not required, provided there are no combustibles in the shaft and there are no openings or other pen-

etrations through the shaft enclosure to the interior of the building.

707.12 Enclosure at the top. A shaft enclosure that does not extend to the underside of the roof sheathing, deck or slab of the building shall be enclosed at the top with construction of the same fire-resistance rating as the topmost floor penetrated by the shaft, but not less than the fire-resistance rating required for the shaft enclosure.

707.13 Refuse and laundry chutes. Refuse and laundry chutes, access and termination rooms and incinerator rooms shall meet the requirements of Sections 707.13.1 through 707.13.6.

Exception: Chutes serving and contained within a single dwelling unit.

707.13.1 Refuse and laundry chute enclosures. A shaft enclosure containing a refuse or laundry chute shall not be used for any other purpose and shall be enclosed in accordance with Section 707.4. Openings into the shaft, including those from access rooms and termination rooms, shall be protected in accordance with this section and Section 715. Openings into chutes shall not be located in corridors. Doors shall be self- or automatic closing upon the actuation of a smoke detector in accordance with Section 715.4.7.3, except that heat-activated closing devices shall be permitted between the shaft and the termination room.

707.13.2 Materials. A shaft enclosure containing a refuse or laundry chute shall be constructed of materials as permitted by the building type of construction.

707.13.3 Refuse and laundry chute access rooms. Access openings for refuse and laundry chutes shall be located in rooms or compartments enclosed by a fire barrier that has a fire-resistance rating of not less than 1 hour. Openings into the access rooms shall be protected by opening protectives having a fire protection rating of not less than $3/4$ hour. Doors shall be self- or automatic closing upon the detection of smoke in accordance with Section 715.4.7.3.

707.13.4 Termination room. Refuse and laundry chutes shall discharge into an enclosed room separated from the remainder of the building by a fire barrier that has a fire-resistance rating of not less than 1 hour. Openings into the termination room shall be protected by opening protectives having a fire protection rating of not less than $3/4$ hour. Doors shall be self- or automatic closing upon the detection of smoke in accordance with Section 715.4.7.3. Refuse chutes shall not terminate in an incinerator room. Refuse and laundry rooms that are not provided with chutes need only comply with Table 508.2.

707.13.5 Incinerator room. Incinerator rooms shall comply with Table 508.2.

707.13.6 Automatic sprinkler system. An approved automatic sprinkler system shall be installed in accordance with Section 903.2.10.2.

707.14 Elevator, dumbwaiter and other hoistways. Elevator, dumbwaiter and other hoistway enclosures shall be constructed in accordance with Section 707 and Chapter 30.

707.14.1 Elevator lobby. An enclosed elevator lobby shall be provided at each floor where an elevator shaft enclosure

connects more than two stories in high-rise buildings, Group A, E, H, I, L, R-1 and R-2 occupancies and other applications listed in Section 111 regulated by the Office of the State Fire Marshal, and more than three stories for all other occupancies. The lobby shall separate the elevator shaft enclosure doors from each floor by fire partitions equal to the fire-resistance rating of the corridor and the required opening protection. Elevator lobbies shall have at least one means of egress complying with Chapter 10 and other provisions within this code.

Exceptions:

1. Enclosed elevator lobbies are not required at the street floor, provided the entire street floor is equipped with an automatic sprinkler system in accordance with Section 903.3.1.1.
2. Elevators not required to be located in a shaft in accordance with Section 707.2 are not required to have enclosed elevator lobbies.
3. [SFM] In other than high-rise buildings, where additional doors are provided at the hoistway opening in accordance with Section 3002.6. Such doors shall be tested in accordance with UL 1784 without an artificial bottom seal.
4. [SFM] In other than high-rise buildings, Group A, E, H, I, L, R-1 and R-2 occupancies and other applications listed in Section 111 regulated by the Office of the State Fire Marshal, enclosed elevator lobbies are not required where the building is protected by an automatic sprinkler system installed in accordance with Section 903.3.1.1 or 903.3.1.2.
5. [SFM] In other than high-rise buildings, smoke partitions shall be permitted in lieu of fire partitions to separate the elevator lobby at each floor where the building is equipped throughout with an automatic sprinkler system installed in accordance with Section 903.3.1.1 or 903.3.1.2.
6. [SFM] When approved, in other than Group I-2 occupancies, enclosed elevator lobbies are not required where the elevator hoistway is pressurized in accordance with Section 707.14.2.
7. [SFM] In other than high-rise buildings, enclosed elevator lobbies are not required where the hoistway door has a fire-protection rating as required by Section 711.4 and the hoistway door opening is also protected by a listed and labeled smoke containment system complying with ICC ES AC 77.

707.14.2 Enclosed elevator lobby pressurization alternative. Where elevator hoistway pressurization is provided in lieu of required enclosed elevator lobbies, the pressurization system shall comply with this section.

707.14.2.1 Pressurization requirements. Elevator hoistways shall be pressurized to maintain a minimum positive pressure of 0.04 inches of water column (1.00 Pa) and a maximum positive pressure of 0.06 inches of water column (1.49 Pa) with respect to adjacent occupied space on all floors. This pressure shall be measured at the midpoint of each hoistway door, with all ground floor level hoistway doors open and all other hoistway doors closed. The supply air intake shall be from an outside,

uncontaminated source located a minimum distance of 20 feet (6096 mm) from any air exhaust system or outlet.

707.14.2.2 Ducts for system. Any duct system that is part of the pressurization system shall be protected with the same fire-resistance rating as required for the elevator shaft enclosure.

707.14.2.3 Fan system. The fan system provided for the pressurization system shall be as required by this section.

707.14.2.3.1 Fire resistance. When located within the building, the fan system that provides the pressurization shall be protected with the same fire-resistance rating required for the elevator shaft enclosure.

707.14.2.3.2 Smoke detection. The fan system shall be equipped with a smoke detector that will automatically shut down the fan system when smoke is detected within the system.

707.14.2.3.3 Separate systems. A separate fan system shall be used for each bank of elevators.

707.14.2.3.4 Fan capacity. The supply fan shall either be adjustable with a capacity of at least 1,000 cfm (.4719 m³/s) per door, or that specified by a registered design professional to meet the requirements of a designed pressurization system.

707.14.2.4 Standby power. The pressurization system shall be provided with standby power from the same source as other required emergency systems for the building.

707.14.2.5 Activation of pressurization system. The elevator pressurization system shall be activated upon activation of the building fire alarm system or upon activation of the elevator lobby smoke detectors.

**SECTION 708
FIRE PARTITIONS**

708.1 General. The following wall assemblies shall comply with this section:

1. Walls separating dwelling units in the same building.
2. Walls separating sleeping units in occupancies in Group R-1 hotel, R-2 and I-1 occupancies.
3. Walls separating tenant spaces in covered mall buildings as required by Section 402.7.2.
4. Corridor walls as required by Section 1017.1.
5. Elevator lobby separation as required by Section 707.14.1.
6. Residential aircraft hangars.
7. Walls separating enclosed tenant spaces in high-rise buildings and in buildings of Types I, IIA, IIIA, IV or VA construction of Group A, E, H and I occupancies and other applications listed in Section 111 regulated by the Office of the State Fire Marshal.

708.2 Materials. The walls shall be of materials permitted by the building type of construction.

708.3 Fire-resistance rating. Fire partitions shall have a fire-resistance rating of not less than 1 hour.

Exceptions:

1. Corridor walls as permitted by Table 1017.1.

TABLE 720.1(2)—continued
 RATED FIRE-RESISTANCE PERIODS FOR VARIOUS WALLS AND PARTITIONS a,o,p

MATERIAL	ITEM NUMBER	CONSTRUCTION	MINIMUM FINISHED THICKNESS FACE-TO-FACE ^b (inches)			
			4 hour	3 hour	2 hour	1 hour
14. Wood studs-interior partition with gypsum wallboard each side	14-1.1 ^{h,m}	2" × 4" wood studs 16" on center with two layers of 3/8" regular gypsum wallboard ^e each side, 4d cooler ⁿ or wallboard ⁿ nails at 8" on center first layer, 5d cooler ⁿ or wallboard ⁿ nails at 8" on center second layer with laminating compound between layers, joints staggered. First layer applied full length vertically, second layer applied horizontally or vertically	—	—	—	5
	14-1.2 ^{l,m}	2" × 4" wood studs 16" on center with two layers 1/2" regular gypsum wallboard ^e applied vertically or horizontally each side ^k , joints staggered. Nail base layer with 5d cooler ⁿ or wallboard ⁿ nails at 8" on center face layer with 8d cooler ⁿ or wallboard ⁿ nails at 8" on center.	—	—	—	5 1/2
	14-1.3 ^{l,m}	2" × 4" wood studs 24" on center with 5/8" Type X gypsum wallboard ^e applied vertically or horizontally nailed with 6d cooler ⁿ or wallboard ⁿ nails at 7" on center with end joints on nailing members. Stagger joints each side.	—	—	—	4 3/4
	14-1.4 ^l	2" × 4" fire-retardant-treated wood studs spaced 24" on center with one layer of 5/8" Type X gypsum wallboard ^e applied with face paper grain (long dimension) parallel to studs. Wallboard attached with 6d cooler ⁿ or wallboard ⁿ nails at 7" on center.	—	—	—	4 3/4 ^d
	14-1.5 ^{l,m}	2" × 4" wood studs 16" on center with two layers 5/8" Type X gypsum wallboard ^e each side. Base layers applied vertically and nailed with 6d cooler ⁿ or wallboard ⁿ nails at 9" on center. Face layer applied vertically or horizontally and nailed with 8d cooler ⁿ or wallboard ⁿ nails at 7" on center. For nail-adhesive application, base layers are nailed 6" on center. Face layers applied with coating of approved wallboard adhesive and nailed 12" on center.	—	—	6	—
	14-1.6 ^l	2" × 3" fire-retardant-treated wood studs spaced 24" on center with one layer of 5/8" Type X gypsum wallboard ^e applied with face paper grain (long dimension) at right angles to studs. Wallboard attached with 6d cement-coated box nails spaced 7" on center.	—	—	—	3 5/8 ^d
15. Exterior or interior walls	15-1.1 ^{l,m}	Exterior surface with 3/4" drop siding over 1/2" gypsum sheathing on 2" × 4" wood studs at 16" on center, interior surface treatment as required for 1-hour-rated exterior or interior 2" × 4" wood stud partitions. Gypsum sheathing nailed with 1 3/4" by No. 11 gage by 7/16" head galvanized nails at 8" on center. Siding nailed with 7d galvanized smooth box nails.	—	—	—	Varies
	15-1.2 ^{l,m}	2" × 4" wood studs 16" on center with metal lath and 3/4" cement plaster on each side. Lath attached with 6d common nails 7" on center driven to 1" minimum penetration and bent over. Plaster mix 1:4 for scratch coat and 1:5 for brown coat, by volume, cement to sand.	—	—	—	5 3/8
	15-1.3 ^{l,m}	2" × 4" wood studs 16" on center with 7/8" cement plaster (measured from the face of studs) on the exterior surface with interior surface treatment as required for interior wood stud partitions in this table. Plaster mix 1:4 for scratch coat and 1:5 for brown coat, by volume, cement to sand.	—	—	—	Varies
	15-1.4	3 5/8" No. 16 gage noncombustible studs 16" on center with 7/8" cement plaster (measured from the face of the studs) on the exterior surface with interior surface treatment as required for interior, nonbearing, noncombustible stud partitions in this table. Plaster mix 1:4 for scratch coat and 1:5 for brown coat, by volume, cement to sand.	—	—	—	Varies ^d

(continued)

TABLE 720.1(2)—continued
 RATED FIRE-RESISTANCE PERIODS FOR VARIOUS WALLS AND PARTITIONS ^{a,o,p}

MATERIAL	ITEM NUMBER	CONSTRUCTION	MINIMUM FINISHED THICKNESS FACE-TO-FACE ^b (inches)			
			4 hour	3 hour	2 hour	1 hour
15. Exterior or interior walls (continued)	15-1.5 ^m	2 1/4" x 3 3/4" clay face brick with cored holes over 1/2" gypsum sheathing on exterior surface of 2" x 4" wood studs at 16" on center and two layers 5/8" Type X gypsum wallboard ^c on interior surface. Sheathing placed horizontally or vertically with vertical joints over studs nailed 6" on center with 1 3/4" x No. 11 gage by 7/16" head galvanized nails. Inner layer of wallboard placed horizontally or vertically and nailed 8" on center with 6d cooler ⁿ or wallboard ⁿ nails. Outer layer of wallboard placed horizontally or vertically and nailed 8" on center with 8d cooler ⁿ or wallboard ⁿ nails. All joints staggered with vertical joints over studs. Outer layer joints taped and finished with compound. Nail heads covered with joint compound. 0.035 inch (No. 20 galvanized sheet gage) corrugated galvanized steel wall ties 3/4" by 6 5/8" attached to each stud with two 8d cooler ⁿ or wallboard ⁿ nails every sixth course of bricks.	—	—	10	—
	15-1.6 ^{1,m}	2" x 6" fire-retardant-treated wood studs 16" on center. Interior face has two layers of 5/8" Type X gypsum with the base layer placed vertically and attached with 6d box nails 12" on center. The face layer is placed horizontally and attached with 8d box nails 8" on center at joints and 12" on center elsewhere. The exterior face has a base layer of 5/8" Type X gypsum sheathing placed vertically with 6d box nails 8" on center at joints and 12" on center elsewhere. An approved building paper is next applied, followed by self-furred exterior lath attached with 2 1/2", No. 12 gage galvanized roofing nails with a 3/8" diameter head and spaced 6" on center along each stud. Cement plaster consisting of a 1/2" brown coat is then applied. The scratch coat is mixed in the proportion of 1:3 by weight, cement to sand with 10 pounds of hydrated lime and 3 pounds of approved additives or admixtures per sack of cement. The brown coat is mixed in the proportion of 1:4 by weight, cement to sand with the same amounts of hydrated lime and approved additives or admixtures used in the scratch coat.	—	—	8 1/4	—
	15-1.7 ^{1,m}	2" x 6" wood studs 16" on center. The exterior face has a layer of 5/8" Type X gypsum sheathing placed vertically with 6d box nails 8" on center at joints and 12" on center elsewhere. An approved building paper is next applied, followed by 1" by No. 18 gage self-furred exterior lath attached with 8d by 2 1/2" long galvanized roofing nails spaced 6" on center along each stud. Cement plaster consisting of a 1/2" scratch coat, a bonding agent and a 1/2" brown coat and a finish coat is then applied. The scratch coat is mixed in the proportion of 1:3 by weight, cement to sand with 10 pounds of hydrated lime and 3 pounds of approved additives or admixtures per sack of cement. The brown coat is mixed in the proportion of 1:4 by weight, cement to sand with the same amounts of hydrated lime and approved additives or admixtures used in the scratch coat. The interior is covered with 3/8" gypsum lath with 1" hexagonal mesh of 0.035 inch (No. 20 B.W. gage) woven wire lath furred out 5/16" and 1" perlite or vermiculite gypsum plaster. Lath nailed with 1 1/8" by No. 13 gage by 19/64" head plasterboard glued nails spaced 5" on center. Mesh attached by 1 3/4" by No. 12 gage by 3/8" head nails with 3/8" furrings, spaced 8" on center. The plaster mix shall not exceed 100 pounds of gypsum to 2 1/2 cubic feet of aggregate.	—	—	8 3/8	—
	15-1.8 ^{1,m}	2" x 6" wood studs 16" on center. The exterior face has a layer of 5/8" Type X gypsum sheathing placed vertically with 6d box nails 8" on center at joints and 12" on center elsewhere. An approved building paper is next applied, followed by 1 1/2" by No. 17 gage self-furred exterior lath attached with 8d by 2 1/2" long galvanized roofing nails spaced 6" on center along each stud. Cement plaster consisting of a 1/2" scratch coat, and a 1/2" brown coat is then applied. The plaster may be placed by machine. The scratch coat is mixed in the proportion of 1:4 by weight, plastic cement to sand. The brown coat is mixed in the proportion of 1:5 by weight, plastic cement to sand. The interior is covered with 3/8" gypsum lath with 1" hexagonal mesh of No. 20 gage woven wire lath furred out 5/16" and 1" perlite or vermiculite gypsum plaster. Lath nailed with 1 1/8" by No. 13 gage by 19/64" head plasterboard glued nails spaced 5" on center. Mesh attached by 1 3/4" by No. 12 gage by 3/8" head nails with 3/8" furrings, spaced 8" on center. The plaster mix shall not exceed 100 pounds of gypsum to 2 1/2 cubic feet of aggregate.	—	—	8 3/8	—

(continued)

CHAPTER 7A [SFM]

MATERIALS AND CONSTRUCTION METHODS FOR EXTERIOR WILDFIRE EXPOSURE

SECTION 701A SCOPE, PURPOSE AND APPLICATION

701A.1 Scope. This chapter applies to building materials, systems and/or assemblies used in the exterior design and construction of new buildings located within a Wildland-Urban Interface Fire Area as defined in Section 702A.

701A.2 Purpose. The purpose of this chapter is to establish minimum standards for the protection of life and property by increasing the ability of a building located in any Fire Hazard Severity Zone within State Responsibility Areas or any Wildland-Urban Interface Fire Area to resist the intrusion of flames or burning embers projected by a vegetation fire and contributes to a systematic reduction in conflagration losses.

701A.3 Application. New buildings located in any Fire Hazard Severity Zone within State Responsibility Areas or any Wildland-Urban Interface Fire Area designated by the enforcing agency for which an application for a building permit is submitted on or after December 1, 2005, shall comply with the following sections:

1. **704A.1—Roofing**
2. **704A.2—Attic Ventilation**

701A.3.1 Alternates for materials, design, tests, and methods of construction. The enforcing agency is permitted to modify the provisions of this chapter for site-specific conditions in accordance with Appendix Chapter 1, Section 104.10. When required by the enforcing agency for the purposes of granting modifications, a fire protection plan shall be submitted in accordance with the California Fire Code, Chapter 47.

701A.3.2 New buildings located in any fire hazard severity zone. New buildings located in any Fire Hazard Severity Zone shall comply with one of the following:

1. **State Responsibility Areas.** New building located in any Fire Hazard Severity Zone within State Responsibility Areas, for which an application for a building permit is submitted on or after January 1, 2008, shall comply with all sections of this chapter.
2. **Local Agency Very-High Fire Hazard Severity Zone.** New buildings located in any Local Agency Very-High Fire Hazard Severity Zone for which an application for a building permit is submitted on or after July 1, 2008, shall comply with all sections of this chapter.
3. **Wildland-Urban Interface Fire Area designated by the enforcing agency.** New buildings located in any Wildland-Urban Interface Fire Area designated by the enforcing agency for which an application for a building permit is submitted on or after January 1, 2008, shall comply with all sections of this chapter.

701A.3.2.1 Inspection and certification. Building permit applications and final completion approvals for buildings within the scope and application of this chapter shall comply with the following:

701A.3.2.2 The local building official shall, prior to construction, provide the owner or applicant a certification that the building as proposed to be built complies with all applicable state and local building standards, including those for materials and construction methods for wildfire exposure as described in this chapter.

701A.3.2.3 The local building official shall, upon completion of construction, provide the owner or applicant with a copy of the final inspection report that demonstrates the building was constructed in compliance with all applicable state and local building standards, including those for materials and construction methods for wildfire exposure as described in this chapter.

701A.3.2.4 Prior to building permit final approval the property shall be in compliance with the vegetation clearance requirements prescribed in California Public Resources Code 4291 California Government Code Section 51182.

SECTION 702A DEFINITIONS

For the purposes of this chapter, certain terms are defined below:

CDF DIRECTOR means the Director of the California Department of Forestry and Fire Protection.

FIRE PROTECTION PLAN is a document prepared for a specific project or development proposed for a Wildland Urban Interface Fire Area. It describes ways to minimize and mitigate potential for loss from wildfire exposure.

The Fire Protection Plan shall be in accordance with this chapter and the California Fire Code, Chapter 47. When required by the enforcing agency for the purposes of granting modifications, a fire protection plan shall be submitted. Only locally adopted ordinances that have been filed with the California Building Standards Commission or the Department of Housing and Community Development in accordance with Section 101.8 shall apply.

FIRE HAZARD SEVERITY ZONES are geographical areas designated pursuant to California Public Resources Codes Sections 4201 through 4204 and classified as Very High, High, or Moderate in State Responsibility Areas or as Local Agency Very High Fire Hazard Severity Zones designated pursuant to California Government Code, Sections 51175 through 51189. See California Fire Code Article 86.

The California Code of Regulations, Title 14, Section 1280, entitles the maps of these geographical areas as “Maps of the Fire Hazard Severity Zones in the State Responsibility Area of California.”

IGNITION-RESISTANT MATERIAL is any product which, when tested in accordance with ASTM E 84 for a period of 30 minutes, shall have a flame spread of not over 25 and show no evidence of progressive combustion. In addition, the flame front shall not progress more than 10½ feet (3200 mm) beyond the centerline of the burner at any time during the test.

Materials shall pass the accelerated weathering test and be identified as exterior type, in accordance with ASTM D 2898 and ASTM D 3201. All materials shall bear identification showing the fire performance rating thereof. That identification shall be issued by ICC-ES or a testing facility recognized by the State Fire Marshal having a service for inspection of materials at the factory.

Fire-Retardant-Treated Wood or noncombustible materials as defined in Section 202 shall satisfy the intent of this section.

The enforcing agency may use other definitions of ignition-resistant material that reflect wildfire exposure to building materials and/or their materials, performance in resisting ignition.

LOCAL AGENCY VERY HIGH FIRE HAZARD SEVERITY ZONE means an area designated by a local agency upon the recommendation of the CDF Director pursuant to Government Code Sections 51177(c), 51178 and 5118 that is not a state responsibility area and where a local agency, city, county, city and county, or district is responsible for fire protection.

STATE RESPONSIBILITY AREA means lands that are classified by the Board of Forestry pursuant to Public Resources Code Section 4125 where the financial responsibility of preventing and suppressing forest fires is primarily the responsibility of the state.

WILDFIRE is any uncontrolled fire spreading through vegetative fuels that threatens to destroy life, property, or resources as defined in Public Resources Code Sections 4103 and 4104.

WILDFIRE EXPOSURE is one or a combination of radiant heat, convective heat, direct flame contact and burning embers being projected by vegetation fire to a structure and its immediate environment.

WILDLAND-URBAN INTERFACE FIRE AREA is a geographical area identified by the state as a “Fire Hazard Severity Zone” in accordance with the Public Resources Code Sections 4201 through 4204 and Government Code Sections 51175 through 51189, or other areas designated by the enforcing agency to be at a significant risk from wildfires.

**SECTION 703A
STANDARDS OF QUALITY**

703A.1 General. Material, systems, and methods of construction used shall be in accordance with this Chapter.

703A.2 Qualification by testing. Material and material assemblies tested in accordance with the requirements of Section 703A shall be accepted for use when the results and conditions

of those tests are met. Testing shall be performed by a testing agency approved by the State Fire Marshal or identified by an ICC-ES report.

703A.3 Standards of quality. The State Fire Marshal standards listed below and as referenced in this chapter are located in the California Referenced Standards Code, Part 12 and Chapter 35 of this code.

SFM 12-7A-1, Exterior Wall Siding and Sheathing.

SFM 12-7A-2, Exterior Window.

SFM 12-7A-3, Under Eave.

SFM 12-7A-4, Decking.

**SECTION 704A
MATERIALS, SYSTEMS AND
METHODS OF CONSTRUCTION**

704A.1 Roofing.

704A.1.1 General. Roofs shall comply with the requirements of Chapter 7A and Chapter 15. Roofs shall have a roofing assembly installed in accordance with its listing and the manufacturer's installation instructions.

704A.1.2 Roof coverings. Where the roof profile allows a space between the roof covering and roof decking, the spaces shall be constructed to prevent the intrusion of flames and embers, be firestopped with approved materials or have one layer of 72 pound (32.4 kg) mineral-surfaced nonperforated cap sheet complying with ASTM D3909 installed over the combustible decking.

704A.1.3 Roof valleys. When provided, valley flashings shall be not less than 0.019-inch (0.48 mm) (No. 26 galvanized sheet gage) corrosion-resistant metal installed over a minimum 36-inch-wide (914 mm) underlayment consisting of one layer of 72 pound (32.4 kg) mineral-surfaced nonperforated cap sheet complying with ASTM D3909 running the full length of the valley.

704A.1.4 Reserved.

704A.1.5 Roof gutters. Roof gutters shall be provided with the means to prevent the accumulation of leaves and debris in the gutter.

704A.2 Attic ventilation.

704A.2.1 General. When required by Chapter 15, roof and attic vents shall resist the intrusion of flame and embers into the attic area of the structure, or shall be protected by corrosion-resistant, noncombustible wire mesh with openings a minimum of 1/8-inch (3.2 mm) and shall not exceed 1/4-inch (6 mm) or its equivalent.

704A.2.2 Eave or cornice vents. Vents shall not be installed in eaves and cornices.

Exception: Eave and cornice vents may be used provided they resist the intrusion of flame and burning embers into the attic area of the structure.

704A.2.3 Eave protection. Eaves and soffits shall meet the requirements of SFM 12-7A-3 or shall be protected by ignition-resistant materials or noncombustible construction on the exposed underside.

704A.3 Exterior walls.

704A.3.1 General. Exterior walls shall be approved noncombustible or ignition-resistant material, heavy timber, or log wall construction or shall provide protection from the intrusion of flames and embers in accordance with standard SFM 12-7A-1.

704A.3.1.1 Exterior wall coverings. Exterior wall coverings shall extend from the top of the foundation to the roof, and terminate at 2-inch (50.8 mm) nominal solid wood blocking between rafters at all roof overhangs, or in the case of enclosed eaves, terminate at the enclosure.

704A.3.2 Exterior wall openings. Exterior wall openings shall be in accordance with this section.

704A.3.2.1 Exterior wall vents. Unless otherwise prohibited by other provisions of this code, vent openings in exterior walls shall resist the intrusion of flame and embers into the structure or vents shall be screened with a corrosion-resistant, noncombustible wire mesh with 1/4-inch (6 mm) openings or its equivalent.

704A.3.2.2 Exterior glazing and window walls. Exterior windows, window walls, glazed doors, and glazed openings within exterior doors shall be insulating-glass units with a minimum of one tempered pane, or glass block units, or have a fire-resistance rating of not less than 20 minutes, when tested according to NFPA 257, or in accordance with Section 715, or conform to the performance requirements of SFM 12-7A-2.

704A.3.2.3 Exterior door assemblies. Exterior door assemblies shall conform to the performance requirements of standard SFM 12-7A-1 or shall be of approved noncombustible construction, or solid core wood having stiles and rails not less than 1³/₈ inches thick with interior field panel thickness no less than 1¹/₄ inches thick, or shall have a fire-resistance rating of not less than 20 minutes when tested according to NFPA 252, or in accordance with Section 715.

Exception: Noncombustible or exterior fire-retardant treated wood vehicle access doors are not required to comply with this chapter.

704A.4 Decking, floors and underfloor protection.**704A.4.1 Decking.**

704A.4.1.1 Decking surfaces. Decking, surfaces, stair treads, risers, and landings of decks, porches, and balconies where any portion of such surface is within 10 feet (3048 mm) of the primary structure shall comply with one of the following methods:

1. Shall be constructed of ignition-resistant materials and pass the performance requirements of SFM 12-7A-4, Parts A and B.
2. Shall be constructed with heavy timber, exterior fire-retardant-treated wood or approved noncombustible materials.
3. Shall pass the performance requirements of SFM 12-7A-4, Part A, 12-7A-4.7.5.1 only with a net

peak heat release rate of 25kW/sq-ft for a 40-minute observation period and:

- a. Decking surface material shall pass the accelerated weathering test and be identified as exterior type, in accordance with ASTM D 2898 and ASTM D 3201 and;
- b. The exterior wall covering to which the deck is attached and within 10 (3048 mm) feet of the deck shall be constructed of approved noncombustible or ignition resistant material.

Exception: Walls are not required to comply with this subsection if the decking surface material conforms to ASTM E-84 Class B flame spread.

The use of paints, coatings, stains, or other surface treatments are not an approved method of protection as required in this chapter.

704A.4.2 Underfloor and appendages protection.

704A.4.2.1 Underside of appendages and floor projections. The underside of cantilevered and overhanging appendages and floor projections shall maintain the ignition-resistant integrity of exterior walls, or the projection shall be enclosed to the grade.

704A.4.2.2 Unenclosed underfloor protection. Buildings shall have all underfloor areas enclosed to the grade with exterior walls in accordance with Section 704A.3.

Exception: The complete enclosure of under floor areas may be omitted where the underside of all exposed floors, exposed structural columns, beams and supporting walls are protected as required with exterior ignition-resistant material construction or be heavy timber.

704A.5 Ancillary buildings and structures.

704A.5.1 Ancillary buildings and structures. When required by the enforcing agency, ancillary buildings and structures and detached accessory structures shall comply with the provisions of this chapter.

**TABLE 803.5
INTERIOR WALL AND CEILING FINISH REQUIREMENTS BY OCCUPANCY^k**

GROUP	SPRINKLERED ^l			NONSPRINKLERED ^m		
	Exit enclosures and exit passageways ^{a,b}	Corridors	Rooms and enclosed spaces ^c	Exit enclosures and exit passageways ^{a,b}	Corridors	Rooms and enclosed spaces ^c
A-1 & A-2	B	B	C	A	A ^d	B ^e
A-3 ^f , A-4, A-5	B	B	C	A	A ^d	C
B, E, M, R-1, R-4	B	C	C	A	B	C
F	C	C	C	B	C	C
H, L	B	B	C ^g	A	A	B
I-1	B	C	C	A	B	B
I-2, I-2.1	B	B	B ^{h, i}	A	A	B
I-3	A	A ^j	B	—	—	—
I-4	B	B	B ^{h, i}	A	A	B
R-2	C	C	C	B	B	C
R-3, R301	C	C	C	C	C	C
S	C	C	C	B	B	C
U	No restrictions			No restrictions		

For SI: 1 inch = 25.4 mm, 1 square foot = 0.0929 m².

- a. Class C interior finish materials shall be permitted for wainscoting or paneling of not more than 1,000 square feet of applied surface area in the grade lobby where applied directly to a noncombustible base or over furring strips applied to a noncombustible base and fireblocked as required by Section 803.4.1.
- b. In exit enclosures of buildings less than three stories in height of other than Group I-3, Class B interior finish for nonsprinklered buildings and Class C interior finish for sprinklered buildings shall be permitted.
- c. Requirements for rooms and enclosed spaces shall be based upon spaces enclosed by partitions. Where a fire-resistance rating is required for structural elements, the enclosing partitions shall extend from the floor to the ceiling. Partitions that do not comply with this shall be considered enclosing spaces and the rooms or spaces on both sides shall be considered one. In determining the applicable requirements for rooms and enclosed spaces, the specific occupancy thereof shall be the governing factor regardless of the group classification of the building or structure.
- d. Lobby areas in Group A-1, A-2 and A-3 occupancies shall not be less than Class B materials.
- e. Class C interior finish materials shall be permitted in places of assembly with an occupant load of 300 persons or less.
- f. For places of religious worship, wood used for ornamental purposes, trusses, paneling or chancel furnishing shall be permitted.
- g. Class B material is required where the building exceeds two stories.
- h. Class C interior finish materials shall be permitted in administrative spaces.
- i. Class C interior finish materials shall be permitted in rooms with a capacity of four persons or less.
- j. Class B materials shall be permitted as wainscoting extending not more than 48 inches above the finished floor in corridors.
- k. Finish materials as provided for in other sections of this code.
- l. Applies when the exit enclosures, exit passageways, corridors or rooms and enclosed spaces are protected by a sprinkler system installed in accordance with Section 903.3.1.1 or 903.3.1.2.

m. [SFM] Not permitted for Group I-3.

803.8 Insulation. Thermal and acoustical insulation shall comply with Section 719.

803.9 Acoustical ceiling systems. The quality, design, fabrication and erection of metal suspension systems for acoustical tile and lay-in panel ceilings in buildings or structures shall conform with generally accepted engineering practice, the provisions of this chapter and other applicable requirements of this code.

803.9.1 Materials and installation. Acoustical materials complying with the interior finish requirements of Section 803 shall be installed in accordance with the manufacturer’s recommendations and applicable provisions for applying interior finish.

803.9.1.1 Suspended acoustical ceilings. Suspended acoustical ceiling systems shall be installed in accordance with the provisions of ASTM C 635 and ASTM C 636.

803.9.1.2 Fire-resistance-rated construction. Acoustical ceiling systems that are part of fire-resistance-rated construction shall be installed in the same manner used in the assembly tested and shall comply with the provisions of Chapter 7.

**SECTION 804
INTERIOR FLOOR FINISH**

804.1 General. Interior floor finish and floor covering materials shall comply with Sections 804.2 through 804.4.1.

Exception: Floor finishes and coverings of a traditional type, such as wood, vinyl, linoleum or terrazzo, and resilient floor covering materials that are not comprised of fibers.

804.2 Classification. Interior floor finish and floor covering materials required by Section 804.4.1 to be of Class I or II materials shall be classified in accordance with NFPA 253. The

classification referred to herein corresponds to the classifications determined by NFPA 253 as follows: Class I, 0.45 watts/cm² or greater; Class II, 0.22 watts/cm² or greater.

804.3 Testing and identification. Interior floor finish and floor covering materials shall be tested by an approved agency in accordance with NFPA 253 and identified by a hang tag or other suitable method so as to identify the manufacturer or supplier and style, and shall indicate the interior floor finish or floor covering classification according to Section 804.2. Carpet-type floor coverings shall be tested as proposed for use, including underlayment. Test reports confirming the information provided in the manufacturer's product identification shall be furnished to the building official upon request.

804.4 Interior floor finish requirements. In all *other* occupancies *except I-3*, interior floor finish and floor covering materials in exit enclosures, exit passageways, corridors and rooms or spaces not separated from corridors by full-height partitions extending from the floor to the underside of the ceiling shall withstand a minimum critical radiant flux as specified in Section 804.4.1. *For Group I-3 occupancies, see Section 804.4.2.*

804.4.1 Minimum critical radiant flux. Interior floor finish and floor covering materials in exit enclosures, exit passageways and corridors shall not be less than Class I in Group I-2 and not less than Class II in Groups A, B, E, H, I-4, L, M, R-1, R-2 and S. In all areas, floor covering materials shall comply with *ASTM E 648*, and having a smoke density rating of less than 450 per *ASTM E 84*.

Exception: Where a building *other than a Group I-3* is equipped throughout with an automatic sprinkler system in accordance with Section 903.3.1.1 or 903.3.1.2, Class II materials are permitted in any area where Class I materials are required, and materials complying with *ASTM E 648*, and having a smoke density rating of less than 450 per *ASTM E 84* are permitted in any area where Class II materials are required.

804.4.2 Group I-3 occupancy floor surfaces. Interior floor finish and floor coverings occupied by inmates or patients whose personal liberties are restrained shall be noncombustible.

Exception: Noncombustible floor finish and floor coverings in areas where restraint is not used may have carpet or other floor covering materials applied in areas protected by an automatic sprinkler system and meeting *ASTM E 648*, and having a smoke density rating of less than 450 per *ASTM E 84*. The carpeting and carpet padding shall be tested as a unit in accordance with floor Covering Radiant Panel Test meeting Class I and has a critical radiant flux limit of not less than 0.45 watt per centimeter square. The carpeting and padding shall be identified by a hang-tag or other suitable method as to manufacturer and style and shall indicate the classification of the material based on the limits set forth above.

SECTION 805 COMBUSTIBLE MATERIALS IN TYPES I AND II CONSTRUCTION

805.1 Application. Combustible materials installed on or embedded in floors of buildings of Type I or II construction shall comply with Sections 805.1.1 through 805.1.3.

Exception: Stages and platforms constructed in accordance with Sections 410.3 and 410.4, respectively.

805.1.1 Subfloor construction. Floor sleepers, bucks and nailing blocks shall not be constructed of combustible materials, unless the space between the fire-resistance-rated floor construction and the flooring is either solidly filled with approved noncombustible materials or fireblocked in accordance with Section 717, and provided that such open spaces shall not extend under or through permanent partitions or walls.

805.1.2 Wood finish flooring. Wood finish flooring is permitted to be attached directly to the embedded or fireblocked wood sleepers and shall be permitted where cemented directly to the top surface of approved fire-resistance-rated floor construction or directly to a wood subfloor attached to sleepers as provided for in Section 805.1.1.

805.1.3 Insulating boards. Combustible insulating boards not more than 1/2 inch (12.7 mm) thick and covered with approved finish flooring are permitted where attached directly to a noncombustible floor assembly or to wood subflooring attached to sleepers as provided for in Section 805.1.1.

[F] SECTION 806 DECORATIVE MATERIALS AND TRIM

[F] 806.1 General requirements. In occupancies in Groups A, E, I and R-1 and dormitories in Group R-2, curtains, draperies, hangings and other decorative materials suspended from walls or ceilings shall meet the flame propagation performance criteria of NFPA 701 in accordance with Section 806.2 or be noncombustible.

In Groups I-1 and I-2, combustible decorative materials shall meet the flame propagation criteria of NFPA 701 unless the decorative materials, including, but not limited to, photographs and paintings, are of such limited quantities that a hazard of fire development or spread is not present. In Group I-3, combustible decorative materials are prohibited.

Fixed or movable walls and partitions, paneling, wall pads and crash pads applied structurally or for decoration, acoustical correction, surface insulation or other purposes shall be considered interior finish if they cover 10 percent or more of the wall or of the ceiling area, and shall not be considered decorative materials or furnishings.

In Group B and M occupancies, fabric partitions suspended from the ceiling and not supported by the floor shall meet the flame propagation performance criteria in accordance with Section 806.2 and NFPA 701 or shall be noncombustible.

[F] 806.1.1 Noncombustible materials. The permissible amount of noncombustible decorative material shall not be limited.

**CALIFORNIA BUILDING CODE – MATRIX ADOPTION TABLE
CHAPTER 9 – FIRE PROTECTION SYSTEMS**

Adopting Agency	BSC	SFM	HCD			DSA		OSHPD				CSA	DHS	AGR	DWR	CEC	CA	SL	SLC
			1	2	1/AC	AC	SS	1	2	3	4								
Adopt Entire Chapter	X						X ◆	X	X	X	X								
Adopt Entire Chapter as amended (amended sections listed below)		X	X ◆	X ◆															
Adopt only those sections that are listed below						X													
Chapter / Section	Codes																		
901.6.2	CA	X																	
902.1	CA	X																	
Fire Appliance	CA	X																	
903.2	CA	X																	
903.2.1.2	CA	X																	
903.2.1.3	CA	X																	
903.2.3.1	CA	X																	
903.2.5	CA	X																	
903.2.5.1	CA	X																	
903.2.6	CA	X																	
Table 903.2.13	CA	X																	
903.2.17	CA	X																	
903.3.1.1.1.	CA	X																	
903.3.5	CA	X																	
903.4.2	CA	X																	
904.5 – 904.11	CA	X	X	X															
905.3	CA	X																	
905.3.8 – 905.3.10.1	CA	X																	
907.1.2 – 907.1.4	CA	X																	
907.2	CA	X																	
907.2.1.1	CA	X																	
907.2.1.3	CA	X																	
907.2.3 – 907.2.3.8.3	CA	X																	
907.2.6	CA	X																	
907.2.6.1.1	CA	X																	
907.2.6.2	CA	X																	
907.2.6.2.1	CA	X																	
907.2.6.3.3	CA	X																	
907.2.6.3.4	CA	X																	
907.2.6.4	CA	X																	
907.2.8	CA	X																	
907.2.8.4	CA	X																	

CHAPTER 9 – FIRE PROTECTION SYSTEMS (Continued)

Adopting Agency	BSC	SFM	HCD			DSA		OSHPD				CSA	DHS	AGR	DWR	CEC	CA	SL	SLC
			1	2	1/AC	AC	SS	1	2	3	4								
Adopt Entire Chapter	X						X ◆	X	X	X	X								
Adopt Entire Chapter as amended (amended sections listed below)		X	X ◆	X ◆															
Adopt only those sections that are listed below						X													
Chapter / Section	Codes																		
907.2.10	CA	X																	
907.2.10.1.1	CA	X																	
907.2.10.1.2	CA	X																	
907.2.10.1.4	CA	X																	
907.2.10.1.5	CA	X																	
907.2.10.2	CA	X																	
907.2.10.3	CA	X																	
907.2.10.5	CA	X																	
907.2.12	CA	X																	
907.2.12.1.1	CA	X																	
907.2.12.1.2	CA	X																	
907.2.15 — 907.2.15.3	CA	X																	
907.2.24 — 907.2.28	CA	X																	
907.3.1 Exc.	CA	X																	
907.3.2	CA					X													
907.3.5	CA	X																	
907.3.6	CA	X																	
907.8 — 907.8.4	CA	X																	
907.9.1 w/Exc. 1 & 2	CA	X				X													
907.9.1.1	CA	X				X													
907.9.1.2	IBC					X													
907.9.1.3	IBC					X													
Table 907.9.1.3	CA	X				X													
907.9.1.4	CA	X				X													
907.9.1.5	CA	X				X													
907.9.2	CA	X				X													
907.9.2.1	CA	X				X													
907.10	CA	X																	
907.11	CA	X																	
907.14	CA	X																	
907.16	CA	X																	
909.5.2	CA	X																	
909.20.2.1 — 909.20.2.4	CA	X																	

CHAPTER 9 – FIRE PROTECTION SYSTEMS (Continued)

Adopting Agency	BSC	SFM	HCD			DSA		OSHDPD				CSA	DHS	AGR	DWR	CEC	CA	SL	SLC
			1	2	1/AC	AC	SS	1	2	3	4								
Adopt Entire Chapter	X						X ◆	X	X	X	X								
Adopt Entire Chapter as amended (amended sections listed below)		X	X ◆	X ◆															
Adopt only those sections that are listed below						X													
Chapter / Section	Codes																		
909.20.4 — 909.20.4.1	CA	X																	
910.1	CA	X																	
910.3.1	CA	X																	
911.1	CA	X																	
912.3 Exc.	CA	X																	
912.5	CA	X																	

The ◆ designation indicates that the Office of the State Fire Marshal's adoption of this chapter or individual sections is applicable to structures subject to HCD 1 and/or HCD 2 or DSA-SS.

[F] LISTED. Equipment, materials or services included in a list published by an organization acceptable to the building official and concerned with evaluation of products or services that maintains periodic inspection of production of listed equipment or materials or periodic evaluation of services and whose listing states either that the equipment, material or service meets identified standards or has been tested and found suitable for a specified purpose.

[F] MANUAL FIRE ALARM BOX. A manually operated device used to initiate an alarm signal.

[F] MULTIPLE-STATION ALARM DEVICE. Two or more single-station alarm devices that are capable of interconnection such that actuation of one causes all integral or separate audible alarms to operate. It also can consist of one single-station alarm device having connections to other detectors or to a manual fire alarm box.

[F] MULTIPLE-STATION SMOKE ALARM. Two or more single-station alarm devices that are capable of interconnection such that actuation of one causes all integral or separate audible alarms to operate.

[F] NUISANCE ALARM. An alarm caused by mechanical failure, malfunction, improper installation or lack of proper maintenance, or an alarm activated by a cause that cannot be determined.

[F] RECORD DRAWINGS. Drawings (“as built”) that document the location of all devices, appliances, wiring sequences, wiring methods and connections of the components of a fire alarm system as installed.

[F] SINGLE-STATION SMOKE ALARM. An assembly incorporating the detector, the control equipment and the alarm-sounding device in one unit, operated from a power supply either in the unit or obtained at the point of installation.

[F] SMOKE ALARM. A single- or multiple-station alarm responsive to smoke and not connected to a system.

[F] SMOKE DETECTOR. A listed device that senses visible or invisible particles of combustion.

SMOKEPROOF ENCLOSURE. An exit stairway designed and constructed so that the movement of the products of combustion produced by a fire occurring in any part of the building into the enclosure is limited.

SPRINKLER ALARM [SL] *is a local alarm unit assembly or apparatus approved for the service and so constructed and installed that any flow of water from a sprinkler system equal to or greater than that from a single automatic sprinkler will result in an audible alarm signal on the premises.*

SPRINKLER SYSTEM, [SL] *for fire protection purposes, is an integrated system of underground and overhead piping designed in accordance with fire protection engineering standards. The installation includes a water supply, such as a gravity tank, fire pump, reservoir or pressure tank and/or connection by underground piping to a city main. The portion of the sprinkler system above ground is a network of specially sized or hydraulically designed piping installed in a building, structure or area, generally overhead, and to which sprinklers are connected in a systematic pattern. The system includes a controlling valve and a device for actuating alarm when the*

system is in operation. The system is usually activated by heat from a fire and discharges water over the fire area.

[F] STANDPIPE SYSTEM, CLASSES OF. Standpipe classes are as follows:

Class I system. A system providing 2½-inch (64 mm) hose connections to supply water for use by fire departments and those trained in handling heavy fire streams. *[SL] Class I is a dry standpipe system without a directly connected water supply and equipped with 2½-inch (63.5 mm) outlets for use by the fire department or trained personnel.*

Class II system. A system providing 1½-inch (38 mm) hose stations to supply water for use primarily by the building occupants or by the fire department during initial response. *[SL] Class II is a wet standpipe system directly connected to a water supply and equipped with 1½-inch (38.1 mm) outlets and hose intended for use by the building occupants.*

Class III system. A system providing 1½-inch (38 mm) hose stations to supply water for use by building occupants and 2.5-inch (64 mm) hose connections to supply a larger volume of water for use by fire departments and those trained in handling heavy fire streams. *[SL] Class III is a combination standpipe system directly connected to a water supply and equipped with both 1½-inch (38 mm) outlets for use by the building occupants and 2½-inch (64 mm) outlets for use by the fire department or trained personnel, or 2½-inch (64 mm) and 1½-inch (38 mm) outlets when a 1½-inch (38 mm) hose is required. Hose connections for Class III systems may be made through 2½-inch (63.5 mm) hose valves with easily removable 2½-inch by 1½-inch (64 mm by 38 mm) reducers.*

[F] STANDPIPE, TYPES OF. Standpipe types are as follows:

Automatic dry. A dry standpipe system, normally filled with pressurized air, that is arranged through the use of a device, such as dry pipe valve, to admit water into the system piping automatically upon the opening of a hose valve. The water supply for an automatic dry standpipe system shall be capable of supplying the system demand.

Automatic wet. A wet standpipe system that has a water supply that is capable of supplying the system demand automatically.

Manual dry. A dry standpipe system that does not have a permanent water supply attached to the system. Manual dry standpipe systems require water from a fire department pumper to be pumped into the system through the fire department connection in order to meet the system demand.

Manual wet. A wet standpipe system connected to a water supply for the purpose of maintaining water within the system but does not have a water supply capable of delivering the system demand attached to the system. Manual-wet standpipe systems require water from a fire department pumper (or the like) to be pumped into the system in order to meet the system demand.

Semiautomatic dry. A dry standpipe system that is arranged through the use of a device, such as a deluge valve, to admit water into the system piping upon activation of a remote control device located at a hose connection. A remote control activation device shall be provided at each hose connection. The water supply for a semiautomatic dry

standpipe system shall be capable of supplying the system demand.

[F] SUPERVISING STATION. A facility that receives signals and at which personnel are in attendance at all times to respond to these signals.

[F] SUPERVISORY SERVICE. The service required to monitor performance of guard tours and the operative condition of fixed suppression systems or other systems for the protection of life and property.

[F] SUPERVISORY SIGNAL. A signal indicating the need of action in connection with the supervision of guard tours, the fire suppression systems or equipment or the maintenance features of related systems.

[F] SUPERVISORY SIGNAL-INITIATING DEVICE. An initiation device, such as a valve supervisory switch, water-level indicator or low-air pressure switch on a dry-pipe sprinkler system, whose change of state signals an off-normal condition and its restoration to normal of a fire protection or life safety system, or a need for action in connection with guard tours, fire suppression systems or equipment or maintenance features of related systems.

[F] TIRES, BULK STORAGE OF. Storage of tires where the area available for storage exceeds 20,000 cubic feet (566 m³).

[F] TROUBLE SIGNAL. A signal initiated by the fire alarm system or device indicative of a fault in a monitored circuit or component.

[F] VISIBLE ALARM NOTIFICATION APPLIANCE. A notification appliance that alerts by the sense of sight.

[F] WET-CHEMICAL EXTINGUISHING SYSTEM. A solution of water and potassium-carbonate-based chemical, potassium-acetate-based chemical or a combination thereof, forming an extinguishing agent.

[F] WIRELESS PROTECTION SYSTEM. A system or a part of a system that can transmit and receive signals without the aid of wire.

[F] ZONE. A defined area within the protected premises. A zone can define an area from which a signal can be received, an area to which a signal can be sent or an area in which a form of control can be executed.

**SECTION 903
AUTOMATIC SPRINKLER SYSTEMS**

[F] 903.1 General. Automatic sprinkler systems shall comply with this section.

[F] 903.1.1 Alternative protection. Alternative automatic fire-extinguishing systems complying with Section 904 shall be permitted in lieu of automatic sprinkler protection where recognized by the applicable standard and approved by the fire code official.

[F] 903.2 Where required. Approved automatic sprinkler systems in new buildings and structures shall be provided in the locations described in this section.

Exceptions:

1. Spaces or areas in telecommunications buildings used exclusively for telecommunications equipment, asso-

ciated electrical power distribution equipment, batteries and standby engines, provided those spaces or areas are equipped throughout with an automatic fire alarm system and are separated from the remainder of the building by fire barriers consisting of not less than 1-hour fire-resistance-rated walls and 2-hour fire-resistance-rated floor/ceiling assemblies.

2. *[SFM] Automatic fire sprinkler protection for fixed guideway transit systems shall be in accordance with Section 903.2.17.*

[F] 903.2.1 Group A. An automatic sprinkler system shall be provided throughout buildings and portions thereof used as Group A occupancies as provided in this section. For Group A-1, A-2, A-3 and A-4 occupancies, the automatic sprinkler system shall be provided throughout the floor area where the Group A-1, A-2, A-3 or A-4 occupancy is located, and in all floors between the Group A occupancy and the level of exit discharge. For Group A-5 occupancies, the automatic sprinkler system shall be provided in the spaces indicated in Section 903.2.1.5.

[F] 903.2.1.1 Group A-1. An automatic sprinkler system shall be provided for Group A-1 occupancies where one of the following conditions exists:

1. The fire area exceeds 12,000 square feet (1115 m²).
2. The fire area has an occupant load of 300 or more.
3. The fire area is located on a floor other than the level of exit discharge.
4. The fire area contains a multitheater complex.

[F] 903.2.1.2 Group A-2. An automatic sprinkler system shall be provided for Group A-2 occupancies where one of the following conditions exists:

1. The fire area exceeds 5,000 square feet (465 m²);
2. The fire area has an occupant load of 100 or more; or
3. The fire area is located on a floor other than the level of exit discharge.
4. *The structure exceeds 5,000 square feet (465 m²), contains more than one fire area containing a Group A-2 occupancy and is separated into two or more buildings by fire walls of less than four-hour fire-resistance rating without openings.*

[F] 903.2.1.3 Group A-3. An automatic sprinkler system shall be provided for Group A-3 occupancies where one of the following conditions exists:

1. The fire area exceeds 12,000 square feet (1115 m²).
2. The fire area has an occupant load of 300 or more.
3. The fire area is located on a floor other than the level of exit discharge.
4. *The structure exceeds 12,000 square feet (1155 m²), contains more than one fire area containing exhibition and display rooms, and is separated into two or more buildings by fire walls of less than four hour fire resistance rating without openings.*

Exception: Areas used exclusively as participant sports areas where the main floor area is located at the same level as the level of exit discharge of the main entrance and exit.

[F] 903.2.1.4 Group A-4. An automatic sprinkler system shall be provided for Group A-4 occupancies where one of the following conditions exists:

1. The fire area exceeds 12,000 square feet (1115 m²).
2. The fire area has an occupant load of 300 or more.
3. The fire area is located on a floor other than the level of exit discharge.

Exception: Areas used exclusively as participant sports areas where the main floor area is located at the same level as the level of exit discharge of the main entrance and exit.

[F] 903.2.1.5 Group A-5. An automatic sprinkler system shall be provided for Group A-5 occupancies in the following areas: concession stands, retail areas, press boxes and other accessory use areas in excess of 1,000 square feet (93 m²).

[F] 903.2.2 Group E. *Except as provided for in Sections 903.2.2.1 for a new public school campus and 907.2.3.6.1 (fire alarm and detection) for modernization of an existing public school campus building(s),* an automatic sprinkler system shall be provided for Group E occupancies as follows:

1. Throughout all Group E fire areas greater than 20,000 square feet (1858 m²) in area.
2. Throughout every portion of educational buildings below the level of exit discharge.

Exception: An automatic sprinkler system is not required in any fire area or area below the level of exit discharge where every classroom throughout the building has at least one exterior exit door at ground level.

3. *In rooms or areas with special hazards such as laboratories, vocational shops and other such areas where hazardous materials in exempt amounts are used or stored.*
4. *Throughout any Group E structure greater than 20,000 square feet (1155 m²) in area, which contains more than one fire area, and which is separated into two or more buildings by fire walls of less than four-hour fire resistance rating without openings.*

[F] 903.2.2.1 Public schools—Automatic sprinkler system requirements.

[F] 903.2.2.1.1 New public school campus. *A State Fire Marshal-approved automatic sprinkler system shall be provided on all new public school campuses as defined in Section 202 and maintained in accordance with the California Fire Code. See Section 907.2.3.6 for automatic detection requirements and “ceiling-plenum” spaces.*

[F] 903.2.2.1.2 Permanent portable buildings. *A portable building that is used to serve or house students and is certified, as a permanent building on a new public school campus by the public school administration shall comply with the requirements of Section 903.2.2.1.1.*

[F] 903.2.2.1.3 Fire-resistive substitution for new campus. *a new public school campus as defined in*

Section 202 shall be entitled to include in the design and construction documents all of the applicable fire-resistive construction substitutions as permitted by this code.

[F] 903.2.3 Group F-1. An automatic sprinkler system shall be provided throughout all buildings containing a Group F-1 occupancy where one of the following conditions exists:

1. Where a Group F-1 fire area exceeds 12,000 square feet (1115 m²);
2. Where a Group F-1 fire area is located more than three stories above grade plane; or
3. Where the combined area of all Group F-1 fire areas on all floors, including any mezzanines, exceeds 24,000 square feet (2230 m²).

[F] 903.2.3.1 Woodworking operations. An automatic sprinkler system shall be provided throughout all Group F-1 occupancy fire areas that contain woodworking operations in excess of 2,500 square feet (232 m²) in area which generate finely divided combustible waste or use finely divided combustible materials. *[SFM] A fire wall of less than four-hour fire-resistance rating, or any fire wall with openings, shall not be used to establish separate fire areas without openings.*

[F] 903.2.4 Group H. Automatic sprinkler systems shall be provided in high-hazard occupancies as required in Sections 903.2.4.1 through 903.2.4.3.

[F] 903.2.4.1 General. An automatic sprinkler system shall be installed in Group H occupancies.

[F] 903.2.4.2 Group H-5. An automatic sprinkler system shall be installed throughout buildings containing Group H-5 occupancies. The design of the sprinkler system shall not be less than that required by this code for the occupancy hazard classifications in accordance with Table 903.2.4.2. Where the design area of the sprinkler system consists of a corridor protected by one row of sprinklers, the maximum number of sprinklers required to be calculated is 13.

**[F] TABLE 903.2.4.2
GROUP H-5 SPRINKLER DESIGN CRITERIA**

LOCATION	OCCUPANCY HAZARD CLASSIFICATION
Fabrication areas	Ordinary Hazard Group 2
Service corridors	Ordinary Hazard Group 2
Storage rooms without dispensing	Ordinary Hazard Group 2
Storage rooms with dispensing	Extra Hazard Group 2
Corridors	Ordinary Hazard Group 2

[F] 903.2.4.3 Pyroxylin plastics. An automatic sprinkler system shall be provided in buildings, or portions thereof, where cellulose nitrate film or pyroxylin plastics are manufactured, stored or handled in quantities exceeding 100 pounds (45 kg).

[F] 903.2.5 Group I. An automatic sprinkler system shall be provided throughout buildings with a Group I fire area.

Exceptions:

1. Those areas exempted by Section 407.5.
2. When not used in accordance with Section 504.2 or 506.3, an automatic sprinkler system installed in accordance with Section 903.3.1.2 shall be allowed in Group I-1 occupancies.
3. Pursuant to Health and Safety Code Section 13113, Group I-1 occupancies housing ambulatory children only, none of whom are mentally ill or mentally retarded, and the buildings or portions thereof in which such children are housed are not more than two stories in height, and buildings or portions thereof housing such children shall have an automatic fire alarm system activated by approved smoke detectors.
4. Pursuant to Health and Safety Code Section 13113 (d), Group I-1 occupancies, or any alterations thereto, located in Type IA construction in existence on March 4, 1972.

An automatic sprinkler system designed in accordance with Section 903.3.1.3 shall not be utilized in Group I-1.

[F] 903.2.5.1 Group I-3. Every building, or portion thereof, where inmates are restrained shall be protected by an automatic sprinkler system conforming to NFPA 13. The main sprinkler control valve or valves and all other control valves in the system shall be locked in the open position and electrically supervised so that at least an audible and visual alarm will sound at a constantly attended location when valves are closed. The sprinkler branch piping serving cells may be embedded in the concrete construction.

Exceptions: Sprinklers are not required in cells housing two or fewer inmates and the building shall be considered sprinklered throughout when all the following criteria are met:

1. Automatic fire sprinklers shall be mounted outside the cell a minimum of 6 feet (1829 mm) on center and 12 inches (305 mm) from the wall with quick response sprinkler heads. Where spacing permits, the head shall be centered over the cell door opening.
2. The maximum amount of combustibles, excluding linen and clothing, shall be maintained at 3 pounds per inmate.
3. For local detention facilities, each individual housing cell shall be provided with a two-way inmate or sound-actuated audio monitoring system for communication directly to the control station serving the cell(s).
4. The provisions of the exception in Section 804.4.2 shall not apply.

[F] 903.2.6 Group M. An automatic sprinkler system shall be provided throughout buildings containing a Group M occupancy where one of the following conditions exists:

1. Where a Group M fire area exceeds 12,000 square feet (1115 m²);
2. Where a Group M fire area is located more than three stories above grade plane; or

3. Where the combined area of all Group M fire areas on all floors, including any mezzanines, exceeds 24,000 square feet (2230 m²).
4. [SFM] The structure exceeds 24,000 square feet (465 m²), contains more than one fire area containing a Group M occupancy, and is separated into two or more buildings by fire walls of less than four-hour fire-resistance rating without openings.

[F] 903.2.6.1 High-piled storage. An automatic sprinkler system shall be provided in accordance with the California Fire Code in all buildings of Group M where storage of merchandise is in high-piled or rack storage arrays.

[F] 903.2.7 Group R. An automatic sprinkler system installed in accordance with Section 903.3 shall be provided throughout all buildings with a Group R fire area.

Exceptions:

1. Detached one- and two-family dwellings and multiple single-family dwellings (townhouses) not more than three stories above grade plane in height with a separate means of egress, unless specifically required by other sections of this code, or classified as Group R-4.
2. Group U private garages accessory to a Group R-3 occupancy.
3. Group R-3.1 occupancies not housing bedridden clients, not housing nonambulatory clients above the first floor and not housing clients above the second floor.
4. Group R-3.1 occupancies housing only one bedridden client and complying with Section 425.8.3.3.
5. Pursuant to Health and Safety Code Section 13113, occupancies housing ambulatory children only, none of whom are mentally ill or mentally retarded, and the buildings or portions thereof in which such children are housed are not more than two stories in height, and buildings or portions thereof housing such children have an automatic fire alarm system activated by approved smoke detectors.
6. Pursuant to Health and Safety Code Section 13143.6, occupancies licensed for protective social care which house ambulatory clients only, none of whom is a child (under the age of 18 years), or who is elderly (65 years of age or over).

An automatic sprinkler system designed in accordance with Section 903.3.1.3 shall not be utilized in Group R-4.

[F] 903.2.8 Group S-1. An automatic sprinkler system shall be provided throughout all buildings containing a Group S-1 occupancy where one of the following conditions exists:

1. A Group S-1 fire area exceeds 12,000 square feet (1115 m²);
2. A Group S-1 fire area is located more than three stories above grade plane; or
3. The combined area of all Group S-1 fire areas on all floors, including any mezzanines, exceeds 24,000 square feet (2230 m²).

[F] 903.3.1 Standards. Sprinkler systems shall be designed and installed in accordance with Section 903.3.1.1, 903.3.1.2 or 903.3.1.3.

[F] 903.3.1.1 NFPA 13 sprinkler systems. Where the provisions of this code require that a building or portion thereof be equipped throughout with an automatic sprinkler system in accordance with this section, sprinklers shall be installed throughout in accordance with NFPA 13 except as provided in Section 903.3.1.1.1.

903.3.1.1.1 Exempt locations. *In other than Group I-2, I-2.1 and I-3 occupancies,* automatic sprinklers shall not be required in the following rooms or areas where such rooms or areas are protected with an approved automatic fire detection system, in accordance with Section 907.2, that will respond to visible or invisible particles of combustion. Sprinklers shall not be omitted from any room merely because it is damp, of fire-resistance-rated construction or contains electrical equipment.

1. Any room where the application of water, or flame and water, constitutes a serious life or fire hazard.
2. Any room or space where sprinklers are considered undesirable because of the nature of the contents, when approved by the fire code official.
3. Generator and transformer rooms separated from the remainder of the building by walls and floor/ceiling or roof/ceiling assemblies having a fire-resistance rating of not less than 2 hours.
4. In rooms or areas that are of noncombustible construction with wholly noncombustible contents.

[F] 903.3.1.2 NFPA 13R sprinkler systems. Where allowed in buildings of Group R, up to and including four stories in height, automatic sprinkler systems shall be installed throughout in accordance with NFPA 13R.

[F] 903.3.1.2.1 Balconies and decks. Sprinkler protection shall be provided for exterior balconies, decks and ground floor patios of dwelling units where the building is of Type V construction. Sidewall sprinklers that are used to protect such areas shall be permitted to be located such that their deflectors are within 1 inch (25 mm) to 6 inches (152 mm) below the structural members and a maximum distance of 14 inches (356 mm) below the deck of the exterior balconies and decks that are constructed of open wood joist construction.

[F] 903.3.1.3 NFPA 13D sprinkler systems. Where allowed, automatic sprinkler systems in one- and two-family dwellings shall be installed throughout in accordance with NFPA 13D.

[F] 903.3.2 Quick-response and residential sprinklers. Where automatic sprinkler systems are required by this code, quick-response or residential automatic sprinklers shall be installed in the following areas in accordance with Section 903.3.1 and their listings:

1. Throughout all spaces within a smoke compartment containing patient sleeping units in Group I-2 in accordance with this code.
2. Dwelling units, and sleeping units in Group R and I-1 occupancies.
3. Light-hazard occupancies as defined in NFPA 13.

[F] 903.3.3 Obstructed locations. Automatic sprinklers shall be installed with due regard to obstructions that will delay activation or obstruct the water distribution pattern. Automatic sprinklers shall be installed in or under covered kiosks, displays, booths, concession stands, or equipment that exceeds 4 feet (1219 mm) in width. Not less than a 3-foot (914 mm) clearance shall be maintained between automatic sprinklers and the top of piles of combustible fibers.

Exception: Kitchen equipment under exhaust hoods protected with a fire-extinguishing system in accordance with Section 904.

[F] 903.3.4 Actuation. Automatic sprinkler systems shall be automatically actuated unless specifically provided for in this code.

903.3.5 Water supplies. Water supplies for automatic sprinkler systems shall comply with this section and the standards referenced in Section 903.3.1. The potable water supply shall be protected against backflow in accordance with *Health and Safety Code Section 13114.7*.

[F] 903.3.5.1 Domestic services. Where the domestic service provides the water supply for the automatic sprinkler system, the supply shall be in accordance with this section.

[F] 903.3.5.1.1 Limited area sprinkler systems. Limited area sprinkler systems serving fewer than 20 sprinklers on any single connection are permitted to be connected to the domestic service where a wet automatic standpipe is not available. Limited area sprinkler systems connected to domestic water supplies shall comply with each of the following requirements:

1. Valves shall not be installed between the domestic water riser control valve and the sprinklers.

Exception: An approved indicating control valve supervised in the open position in accordance with Section 903.4.

2. The domestic service shall be capable of supplying the simultaneous domestic demand and the sprinkler demand required to be hydraulically calculated by NFPA 13, NFPA 13R or NFPA 13D.

[F] 903.3.5.1.2 Residential combination services. A single combination water supply shall be allowed provided that the domestic demand is added to the sprinkler demand as required by NFPA 13R.

[F] 903.3.5.2 Secondary water supply. A secondary on-site water supply equal to the hydraulically calculated sprinkler demand, including the hose stream require-

ment, shall be provided for high-rise buildings *and Group I-2 occupancies having occupied floors located more than 75 feet above the lowest level of fire department vehicle access* in Seismic Design Category C, D, E or F as determined by this code. The secondary water supply shall have a duration of not less than 30 minutes as determined by the occupancy hazard classification in accordance with NFPA 13.

Exception: Existing buildings.

[F] 903.3.6 Hose threads. Fire hose threads and fittings used in connection with automatic sprinkler systems shall be as prescribed by the fire code official.

[F] 903.4 Sprinkler system monitoring and alarms. All valves controlling the water supply for automatic sprinkler systems, pumps, tanks, water levels and temperatures, critical air pressures and water-flow switches on all sprinkler systems shall be electrically supervised.

Exceptions:

1. Automatic sprinkler systems protecting one- and two-family dwellings.
2. Limited area systems serving fewer than 20 sprinklers.
3. Automatic sprinkler systems installed in accordance with NFPA 13R where a common supply main is used to supply both domestic water and the automatic sprinkler systems and a separate shutoff valve for the automatic sprinkler system is not provided.
4. Jockey pump control valves that are sealed or locked in the open position.
5. Control valves to commercial kitchen hoods, paint spray booths or dip tanks that are sealed or locked in the open position.
6. Valves controlling the fuel supply to fire pump engines that are sealed or locked in the open position.
7. Trim valves to pressure switches in dry, preaction and deluge sprinkler systems that are sealed or locked in the open position.

[F] 903.4.1 Signals. Alarm, supervisory and trouble signals shall be distinctly different and automatically transmitted to an approved central station, remote supervising station or proprietary supervising station as defined in NFPA 72 or, when approved by the fire code official, shall sound an audible signal at a constantly attended location.

Exceptions:

1. Underground key or hub valves in roadway boxes provided by the municipality or public utility are not required to be monitored.
2. Backflow prevention device test valves located in limited area sprinkler system supply piping shall be locked in the open position. In occupancies required to be equipped with a fire alarm system, the backflow preventer valves shall be electrically supervised by a tamper switch installed in accordance with NFPA 72 and separately annunciated.

[F] 903.4.2 Alarms. *One exterior* approved audible device shall be connected to every automatic sprinkler system *in an approved location*. Such sprinkler water-flow alarm devices

shall be activated by water flow equivalent to the flow of a single sprinkler of the smallest orifice size installed in the system. Where a *building* fire alarm system is installed, actuation of the automatic sprinkler system shall actuate the building fire alarm system. *Visible alarm notification appliances shall not be required except when required by Section 907.*

[F] 903.4.3 Floor control valves. Approved supervised indicating control valves shall be provided at the point of connection to the riser on each floor in high-rise buildings *and Group I-2 occupancies having occupied floors located more than 75 feet above the lowest level of fire department vehicle access.*

[F] 903.5 Testing and maintenance. Sprinkler systems shall be tested and maintained in accordance with the *California Fire Code*.

**SECTION 904
ALTERNATIVE AUTOMATIC FIRE-EXTINGUISHING
SYSTEMS**

[F] 904.1 General. Automatic fire-extinguishing systems, other than automatic sprinkler systems, shall be designed, installed, inspected, tested and maintained in accordance with the provisions of this section and the applicable referenced standards.

[F] 904.2 Where required. Automatic fire-extinguishing systems installed as an alternative to the required automatic sprinkler systems of Section 903 shall be approved by the fire code official. Automatic fire-extinguishing systems shall not be considered alternatives for the purposes of exceptions or reductions allowed by other requirements of this code.

[F] 904.2.1 Commercial hood and duct systems. Each required commercial kitchen exhaust hood and duct system required by Section 609 of the *California Fire Code* or Chapter 5 of the *California Mechanical Code* to have a Type I hood shall be protected with an approved automatic fire-extinguishing system installed in accordance with this code.

[F] 904.3 Installation. Automatic fire-extinguishing systems shall be installed in accordance with this section.

[F] 904.3.1 Electrical wiring. Electrical wiring shall be in accordance with the *California Electrical Code*.

[F] 904.3.2 Actuation. Automatic fire-extinguishing systems shall be automatically actuated and provided with a manual means of actuation in accordance with Section 904.11.1.

[F] 904.3.3 System interlocking. Automatic equipment interlocks with fuel shutoffs, ventilation controls, door closers, window shutters, conveyor openings, smoke and heat vents and other features necessary for proper operation of the fire-extinguishing system shall be provided as required by the design and installation standard utilized for the hazard.

[F] 904.3.4 Alarms and warning signs. Where alarms are required to indicate the operation of automatic fire-extinguishing systems, distinctive audible and visible alarms and

3. Buildings with an occupancy in Group A-5.
4. Low-hazard special occupancies in accordance with Section 503.1.1.
5. Buildings with an occupancy in Group H-1, H-2 or H-3 in accordance with Section 415.

[F] 907.2.12.1 Automatic fire detection.

[F] 907.2.12.1.1 Smoke Detection. Smoke detectors shall be provided in accordance with this section. Smoke detectors shall be connected to an automatic fire alarm system. The activation of any detector required by this section shall operate the emergency voice/alarm communication system *in accordance with Section 907.6.2.2*. Smoke detectors shall be located as follows:

1. In each mechanical equipment, electrical, transformer, telephone equipment or similar room which is not provided with sprinkler protection.
2. *In each elevator machine room and in elevator lobby.*

[F] 907.2.12.1.2 Duct smoke detection. *Smoke detectors listed for use in air duct systems shall be provided in accordance with this section and the California Mechanical Code. The activation of any detector required by this section shall initiate a visible and audible supervisory signal at a constantly attended location. Duct smoke detectors shall be located as follows:*

1. In the main return air and exhaust air plenum of each air-conditioning system having a capacity greater than 2,000 cubic feet per minute (cfm) (0.94 m³/s). Such detectors shall be located in a serviceable area downstream of the last duct inlet.
2. At each connection to a vertical duct or riser serving two or more stories from a return air duct or plenum of an air-conditioning system. In Group R-1 and R-2 occupancies a listed smoke detector is allowed to be used in each return air riser carrying not more than 5,000 cfm (2.4 m³/s) and serving not more than 10 air inlet openings.

[F] 907.2.12.2 Emergency voice/alarm communication system. The operation of any automatic fire detector, sprinkler water-flow device or manual fire alarm box shall automatically sound an alert tone followed by voice instructions giving approved information and directions for a general or staged evacuation on a minimum of the alarming floor, the floor above and the floor below in accordance with the building's fire safety and evacuation plans required by Section 404 of the *California Fire Code*. Speakers shall be provided throughout the building by paging zones. As a minimum, paging zones shall be provided as follows:

1. Elevator groups.
2. Exit stairways.
3. Each floor.
4. Areas of refuge as defined in Section 1002.1.

Exception: In Group I-1 and I-2 occupancies, the alarm shall sound in a constantly attended area and a general occupant notification shall be broadcast over the overhead page.

[F] 907.2.12.2.1 Manual override. A manual override for emergency voice communication shall be provided on a selective and all-call basis for all paging zones.

[F] 907.2.12.2.2 Live voice messages. The emergency voice/alarm communication system shall also have the capability to broadcast live voice messages through paging zones on a selective and all-call basis.

[F] 907.2.12.2.3 Standard. The emergency voice/alarm communication system shall be designed and installed in accordance with NFPA 72.

[F] 907.2.12.3 Fire department communication system. An approved two-way, fire department communication system designed and installed in accordance with NFPA 72 shall be provided for fire department use. It shall operate between a fire command center complying with Section 911 and elevators, elevator lobbies, emergency and standby power rooms, fire pump rooms, areas of refuge and inside enclosed exit stairways. The fire department communication device shall be provided at each floor level within the enclosed stairway.

Exception: Fire department radio systems where approved by the fire department.

[F] 907.2.13 Atriums connecting more than two stories. A fire alarm system shall be installed in occupancies with an atrium that connects more than two stories. The system shall be activated in accordance with Section 907.6. Such occupancies in Group A, E or M shall be provided with an emergency voice/alarm communication system complying with the requirements of Section 907.2.12.2.

[F] 907.2.14 High-piled combustible storage areas. An automatic fire detection system shall be installed throughout high-piled combustible storage areas where required by the *California Fire Code*.

[F] 907.2.15 Delayed egress locks. Where delayed egress locks or devices are installed on means of egress doors in accordance with Section 1008.1.8.6, an automatic smoke detection system shall be installed as required by this section and Section 1008.1.8.6.

[F] 907.2.15.1 *In other than Group I occupancies and Group R-4 occupancies for single-story buildings, smoke detectors shall be installed at ceilings throughout all occupied areas and mechanical/electrical spaces. For multiple-story buildings, smoke detectors shall be installed throughout all occupied areas and mechanical/electrical spaces for the story where delayed egress devices are installed. Additional detectors are required on adjacent stories where occupants of those stories utilize the same means of egress.*

[F] 907.2.15.2 For Group I occupancies. *Smoke detectors shall be installed at ceilings throughout all occupied areas and mechanical/electrical spaces of smoke compartments where delayed egress devices are installed. Additional detectors are required in adjacent smoke compartments where occupants of those compartments utilize the same means of egress.*

[F] 907.2.15.3 For Group R-4 occupancies licensed as residential care facilities for the elderly, and housing clients with Alzheimer's disease or dementia residential facilities, smoke detectors shall be installed at ceilings throughout all occupiable rooms and areas and mechanical/electrical rooms and spaces.

[F] 907.2.16 Aerosol storage uses. Aerosol storage rooms and general-purpose warehouses containing aerosols shall be provided with an approved manual fire alarm system where required by the *California Fire Code*.

[F] 907.2.17 Lumber, wood structural panel and veneer mills. Lumber, wood structural panel and veneer mills shall be provided with a manual fire alarm system.

[F] 907.2.18 Underground buildings with smoke exhaust system. Where a smoke exhaust system is installed in an underground building in accordance with this code, automatic fire detectors shall be provided in accordance with this section.

[F] 907.2.18.1 Smoke detectors. A minimum of one smoke detector listed for the intended purpose shall be installed in the following areas:

1. Mechanical equipment, electrical, transformer, telephone equipment, elevator machine or similar rooms.
2. Elevator lobbies.
3. The main return and exhaust air plenum of each air-conditioning system serving more than one story and located in a serviceable area downstream of the last duct inlet.
4. Each connection to a vertical duct or riser serving two or more floors from return air ducts or plenums of heating, ventilating and air-conditioning systems, except that in Group R occupancies, a listed smoke detector is allowed to be used in each return air riser carrying not more than 5,000 cfm (2.4 m³/s) and serving not more than 10 air inlet openings.

[F] 907.2.18.2 Alarm required. Activation of the smoke exhaust system shall activate an audible alarm at a constantly attended location.

[F] 907.2.19 Underground buildings. Where the lowest level of a structure is more than 60 feet (18 288 mm) below the lowest level of exit discharge, the structure shall be equipped throughout with a manual fire alarm system, including an emergency voice/alarm communication system installed in accordance with Section 907.2.12.2.

[F] 907.2.19.1 Public address system. Where a fire alarm system is not required by Section 907.2, a public address system shall be provided that shall be capable of transmitting voice communications to the highest level of exit discharge serving the underground portions of the structure and all levels below.

[F] 907.2.20 Covered mall buildings. Covered mall buildings exceeding 50,000 square feet (4645 m²) in total floor area shall be provided with an emergency voice/alarm communication system. An emergency voice/alarm communication system serving a mall, required or otherwise, shall be

accessible to the fire department. The system shall be provided in accordance with Section 907.2.12.2.

[F] 907.2.21 Residential aircraft hangars. A minimum of one listed smoke alarm shall be installed within a residential aircraft hangar as defined in Section 412.3.1 and shall be interconnected into the residential smoke alarm or other sounding device to provide an alarm that will be audible in all sleeping areas of the dwelling.

[F] 907.2.22 Airport traffic control towers. An automatic fire detection system shall be provided in airport traffic control towers.

[F] 907.2.23 Battery rooms. An approved automatic smoke detection system shall be installed in areas containing stationary storage battery systems having a liquid capacity of more than 50 gallons (189.3 L). The detection system shall be supervised by an approved central, proprietary or remote station service or a local alarm that will sound an audible signal at a constantly attended location.

[F] 907.2.24 Motion picture and television production studio sound stages and approved production facilities.

[F] 907.2.24.1 Sound stages—solid-ceiling sets and platforms. All interior solid-ceiling sets over 600 square feet (55.7 m²) in area, and platforms (when provided) over 600 square feet (55.7 m²) in area and which exceed 3 feet (914 mm) in height shall be protected by one of the following:

1. An approved and listed heat detector system. Heat detectors shall be spaced 30 feet (9144 mm) on center or as required by the manufacturer's installation instructions. Detectors shall be connected to an approved and listed central, proprietary or remote station service or a local alarm which will give an audible signal at a constantly attended location. Such system shall be installed in accordance with *California Fire Code Chapter 9*.
2. The ceiling shall be positioned to allow for the operation of the building's automatic fire sprinkler system after rehearsal, videotaping, filming, or broadcasting of programs has been completed for the day.
3. An approved fire watch.
4. Special hazards shall be reviewed by the fire code official (see *Additional Fire Protection Systems, California Fire Code Section 901.4.3*).

[F] 907.2.24.2 Production locations—solid-ceiling sets and platforms. In buildings with existing fire protection systems and where production intends to construct solid-ceiling sets over 600 square feet (55.7 m²) in area, and platforms over 600 square feet (55.7 m²) in area and which exceed 3 feet (914 mm) in height shall be protected by one of the following:

1. An approved and listed heat detector system. Heat detectors shall be spaced 30 feet (9144 mm) on center or as required by the manufacturer's installation instructions. Detectors shall be connected to an approved and listed central, proprietary or remote station service or a local alarm which will give an audible signal at a constantly attended lo-

caution. Such system shall be installed in accordance with California Fire Code Chapter 9.

2. The ceiling shall be positioned to allow for the operation of the building's automatic fire sprinkler system after rehearsal, videotaping, filming, or broadcasting of programs has been completed for the day.
3. An approved fire watch.
4. Special hazards shall be reviewed by the enforcing agency (see Additional Fire Protection Systems, California Fire Code Section 901.4.3.).

[F] 907.2.24.3 Fire alarm control units. Fire alarm control units shall be California State Fire Marshal listed and shall be utilized in accordance with their listing. Control units may be temporarily supported by sets, platforms or pedestals.

[F] 907.2.24.4 Heat detectors. Heat detection required by this section shall be defined as a portable system as it is intended to be reinstalled when platforms or sets are changed.

Heat detectors shall be secured to standard outlet boxes which may be temporarily supported by sets, platforms or pedestals. Heat detectors shall be provided for solid-ceiling sets and platforms where required by California Fire Code, Section 4605.3 and 4611.14.

[F] 907.2.25 Group C occupancies (every organized camp).

[F] 907.2.25.1 General. Every building and structure used or intended for sleeping purposes shall be provided with an automatic smoke-detector system.

Exceptions:

1. Buildings and structures in existence and in operation prior to January 1, 1985.
2. Tents, tent structures and buildings and structures that do not exceed 25 feet (7620 mm) in any lateral dimensions and where such building or structure is not more than one story.

[F] 907.2.25.2 Camp fire alarm. Every organized camp shall provide and maintain a device or devices suitable for sounding a fire alarm. Such device or devices may be of any type acceptable to the enforcing agency provided they are distinctive in tone from all other signaling devices or systems and shall be audible throughout the camp premises. When an automatic fire alarm system is provided, as required by Section 440.6.6, all signaling devices required by this section shall be of the same type as that used in the automatic system.

[F] 907.2.26 Fixed guideway transits systems fire alarm and communication systems.

[F] 907.2.26.1 General. Every fixed guideway transit station shall be provided with an approved fire alarm system. The alarm and communication systems shall be proprietary, designed and installed so that damage to any one speaker will not render any paging zone of the system inoperative.

Exception: Open stations

The voice alarm and public address system may be a combined system. When approved by the fire department, a communications system may be combined with the voice alarm system and the public address system. Such combined systems shall meet the requirements of the California Electrical Code.

[F] 907.2.26.2 System components. Each station fire alarm system shall consist of:

1. Fire alarm control unit at a location as permitted by the authority having jurisdiction.
2. An alarm annunciator(s). The annunciator(s) shall be located at a point acceptable to the authority having jurisdiction. The annunciator(s) shall indicate the type of device and general location of alarm. All, alarm supervisory and trouble signals shall be transmitted to the local annunciator(s) and the OCC.
3. Manual fire alarm boxes shall be provided throughout passenger platforms and stations.

Exception: Voice alarm reporting devices (emergency telephones) may be used in lieu of manual fire alarm boxes as permitted by the authority having jurisdiction.

Such devices shall provide two-way communication between the OCC and each device. Such devices shall be located as required for manual fire alarm boxes, and shall be distinctly identified by signs, coloring, or other means acceptable to the authority having jurisdiction.

4. Automatic smoke detectors in all ancillary spaces.

Exceptions:

1. Ancillary spaces protected by an approved fixed automatic extinguishing system; or
2. Ancillary spaces protected by quick-response sprinklers.

5. Automatic control of exiting components.

[F] 907.2.26.3 Combined voice alarm/public address system. Each station shall be provided with a one-way paging system(s) capable of transmitting voice, tape or electronically generated messages to all areas of the station. The system(s) shall be configured such that the messages can be initiated from either the emergency management panel (EMP) or the OCC.

[F] 907.2.26.4 Emergency telephones. A dedicated emergency phone system shall be provided in all underground stations to facilitate direct communications for emergency response between remote locations and the EMP.

[F] 907.2.26.4.1 The remote phones shall be located at ends of station platforms, each hose outlet connection and station valve rooms.

[F] 907.2.26.4.2 Provisions shall be made in the design of this system for extensions of the system to the next passenger station or guideway portal.

[F] 907.2.27 Winery caves. An approved manual fire alarm system conforming to the provisions of Section 907.2.1 shall be provided in all Type 3 winery caves.

[F] 907.2.28 Group L. A manual fire alarm system shall be installed throughout buildings containing a Group L occupancy. When Group L occupancies are located in mixed use buildings, at least one manual fire alarm box shall be located in the Group L occupancy.

[F] 907.3 Manual fire alarm boxes. Manual fire alarm boxes shall be installed in accordance with Sections 907.3.1 through 907.3.5.

[F] 907.3.1 Location. Manual fire alarm boxes shall be located not more than 5 feet (1524 mm) from the entrance to each exit. Additional manual fire alarm boxes shall be located so that travel distance to the nearest box does not exceed 200 feet (60 960 mm).

Exception: When individual dwelling units are served by a single exit stairway, additional boxes at other than the ground floor may be omitted.

907.3.2 Height. The height of the manual fire alarm boxes shall be a minimum of 42 inches (1067 mm) and a maximum of 48 inches (1219 mm), measured vertically, from the floor level to the highest point of the activating handle or lever of the box. Manual fire alarm boxes shall also comply with Section 1117B.6 Item 4.

Exception: [DSA-AC] In existing buildings there is no requirement to retroactively relocate existing manual fire alarm boxes to a minimum of 42 inches (1067 mm) and a maximum of 48 inches (1219 mm) from the floor level to the activating handle or lever of the box.

[F] 907.3.3 Color. Manual fire alarm boxes shall be red in color.

[F] 907.3.4 Signs. Where fire alarm systems are not monitored by a supervising station, an approved permanent sign shall be installed adjacent to each manual fire alarm box that reads: WHEN ALARM SOUNDS—CALL FIRE DEPARTMENT.

Exception: Where the manufacturer has permanently provided this information on the manual fire alarm box.

907.3.5 Operation. Manual fire alarm boxes shall be operable with one hand including boxes with protective covers.

[F] 907.3.6 Protective covers. The fire code official is authorized to require the installation of listed manual fire alarm box protective covers to prevent malicious false alarms or to provide the manual fire alarm box with protection from physical damage. The protective cover shall be transparent or red in color with a transparent face to permit visibility of the manual fire alarm box. Each cover shall include proper operating instructions. A protective cover that emits a local alarm signal shall not be installed unless approved. Each cover shall not exceed a combined projection over 4 inches (102 mm) from the surface of the wall into walks, halls, corridors, passageways or aisles.

[F] 907.4 Power supply. The primary and secondary power supplies for the fire alarm system shall be provided in accordance with NFPA 72.

[F] 907.5 Wiring. Wiring shall comply with the requirements of the California Electrical Code and NFPA 72. Wireless protection systems utilizing radio-frequency transmitting devices shall comply with the special requirements for supervision of low-power wireless systems in NFPA 72.

[F] 907.6 Activation. Where an alarm notification system is required by another section of this code, it shall be activated by:

1. An automatic fire alarm system.
2. Sprinkler water-flow devices.
3. Manual fire alarm boxes.

[F] 907.7 Presignal system. Presignal systems shall not be installed unless approved by the fire code official and the fire department. Where a presignal system is installed, 24-hour personnel supervision shall be provided at a location approved by the fire department, in order that the alarm signal can be actuated in the event of fire or other emergency.

[F] 907.8 Zones. Fire alarm systems shall be divided into zones where required by this section. For the purposes of annunciation and notification, zoning shall be in accordance with the following:

1. Where the fire-protective signaling system serves more than one building, each building shall be considered as a separate zone.
2. Each floor of a building shall be considered as a separate zone.
3. Each section of floor of a building that is separated by fire walls or by horizontal exits shall be considered as a separate zone.
4. Each zone shall not exceed 22,500 square feet (2090 m²). The length of any zone shall not exceed 300 feet (91 440 mm) in any direction.

Exception: Automatic sprinkler system zones shall not exceed the area permitted by NFPA 13.

5. For Group I-3 occupancies each cell complex shall be considered a separate zone.
6. Annunciation shall be further divided into zones where deemed necessary by the enforcing agency.

[F] 907.8.1 Annunciation. Alarm, supervisory and trouble signals shall be annunciated in the main control unit by means of an audible signal and a visual display in accordance with NFPA 72. Identification of the type of alarm and supervisory initiating devices, such as manual, automatic, sprinkler waterflow, sprinkler valve supervisory, fire-pump supervisory, etc., shall be separately indicated.

Exception: Group R-3 occupancies.

[F] 907.8.2 Annunciator panel. An annunciator panel complying with Section 907.8.1 and the associated controls shall be provided in an approved remote location where deemed necessary by the enforcing agency. The visual zone indication shall lock in until the system is reset and shall not be canceled by the operation of an audible alarm-silencing switch.

[F] 907.8.3 High-rise buildings. In high-rise buildings and Group I-2 occupancies having occupied floors located more than 75 feet above the lowest level of fire department vehicle access, a separate zone by floor shall be provided for all of the following types of alarm-initiating devices where provided:

1. Smoke detectors.
2. Sprinkler water-flow devices.
3. Manual fire alarm boxes.
4. Other approved types of automatic fire detection devices or suppression systems.

[F] 907.8.4 Notification zoning. Upon activation of initiating devices where occupant notification is required for evacuation, all notification zones shall operate simultaneously throughout the building.

Exceptions:

1. High-rise buildings as permitted in Section 907.2.12.2.
2. In hospitals and convalescent facilities with staff alerting notification appliances or voice/alarm communication, zoning shall be in accordance with the approved fire plan.
3. Detention facilities.
4. Upon approval by the fire code official in buildings which are sprinklered throughout, specific notification zoning shall be permitted where the notification zones are separated by a minimum of a 2 hour fire barrier and 2 hour fire-resistive floor assembly. The system shall have the capability to activate all other notification zones by automatic and manual means.
5. Upon approval by the fire code official in buildings which are sprinklered throughout, specific notification zoning shall be permitted where the activated initiating device or fire extinguishing system is separated from any nonactive notification zones by a minimum of 300 foot (91 440 mm) horizontal distance. The system shall have the capability to activate all other notification zones by automatic and manual means.

[F] 907.9 Alarm notification appliances. Alarm notification appliances shall be provided and shall be listed for their purpose.

[F] 907.9.1 Visible alarms. Visible alarm notification appliances shall be provided in accordance with Sections 907.9.1.1 through 907.9.1.5.

Exceptions:

1. In other than Group I-2 and I-2.1, visible alarm notification appliances are not required in alterations, except where an existing fire alarm system is upgraded or replaced, or a new fire alarm system is installed.
2. Visible alarm notification appliances shall not be required in enclosed exit stairways, exterior exit stairs, and exterior exit ramps.

907.9.1.1 Public and common use areas. Visible alarm notification appliances shall be provided in public use

areas and common use areas, including but not limited to:

1. Sanitary facilities including restrooms, bathrooms and shower rooms.
2. Corridors.
3. Music practice rooms.
4. Band rooms.
5. Gymnasiums.
6. Multipurpose rooms.
7. Occupational shops.
8. Occupied rooms where ambient noise impairs hearing of the fire alarm.
9. Lobbies.
10. Meeting rooms.
11. Classrooms.

[F] 907.9.1.2 Employee work areas. Where employee work areas have audible alarm coverage, the notification appliance circuits serving the employee work areas shall be initially designed with a minimum of 20 percent spare capacity to account for the potential of adding visible notification appliances in the future to accommodate hearing impaired employees.

[F] 907.9.1.3 Groups I-1 and R-1. Group I-1 and R-1 sleeping units in accordance with Table 907.9.1.3 shall be provided with a visible alarm notification appliance, activated by both the in-room smoke alarm and the building fire alarm system.

**[F] TABLE 907.9.1.3
VISIBLE AND AUDIBLE ALARMS**

NUMBER OF SLEEPING UNITS	SLEEPING UNITS WITH VISIBLE AND AUDIBLE ALARMS
6 to 25	2
26 to 50	4
51 to 75	7
76 to 100	9
101 to 150	12
151 to 200	14
201 to 300	17
301 to 400	20
401 to 500	22
501 to 1,000	5% of total
1,001 and over	50 plus 3 for each 100 over 1,000

[DSA-AC & SFM] Also see Chapter 11B, Section 1111B.4.5, Table 11B-3 and Table 11B-4.

[F] 907.9.1.4 Group R-2. In Group R-2 occupancies required by Section 907 to have a fire alarm system, all dwelling units and sleeping units shall be provided with the capability to support visible alarm notification appliances in accordance with NFPA 72.

[F] 907.9.1.5 Groups I-1, R-3.1 and R-4. Protective social care facilities which house persons who are hearing impaired, shall be provided with notification appliances for the hearing impaired installed in accordance with NFPA 72 and which shall activate upon initiation of the fire alarm system or the smoke alarms.

907.9.2 Audible alarms. Audible alarm notification appliances shall be provided and shall sound a distinctive sound that is not to be used for any purpose other than that of a fire alarm. The audible alarm notification appliances shall provide a sound pressure level of 15 decibels (dBA) above the average ambient sound level or 5 dBA above the maximum sound level having a duration of at least 60 seconds, whichever is greater, in every occupied space within the building. The minimum sound pressure levels shall be: 75 dBA in occupancies in Groups R and I-1; 90 dBA in mechanical equipment rooms and 60 dBA in other occupancies. The maximum sound pressure level for audible alarm notification appliances shall be 110 dBA at the minimum hearing distance from the audible appliance. Where the average ambient noise is greater than 95 dBA, visible alarm notification appliances shall be provided in accordance with NFPA 72 and audible alarm notification appliances shall not be required.

In Group I-2 occupancies, audible appliances placed in patient areas shall be only chimes or similar sounding devices for alerting staff.

Exception: Visible alarm notification appliances shall be allowed in lieu of audible alarm notification appliances in patient areas of Group I-2 occupancies.

[F] 907.9.2.1 Audible alarm signal. *The audible signal shall be the standard fire alarm evacuation signal, ANSI S3.41 Audible Emergency Evacuation Signal, “three pulse temporal pattern,” as described in NFPA 72.*

Exception: *The use of the existing evacuation signaling scheme shall be permitted where approved by the enforcing agency.*

907.10 Fire safety functions. Automatic fire detectors utilized for the purpose of performing fire safety functions shall be connected to the building’s fire alarm control unit where a fire alarm system is installed. Detectors shall, upon actuation, perform the intended function and activate the alarm notification appliances or a visible and audible supervisory signal at a constantly attended location. In buildings not required to be equipped with a fire alarm system, the automatic fire detector shall be powered by normal electrical service and, upon actuation, perform the intended function. The detectors shall be located in accordance with Chapter 5 of NFPA 72.

[F] 907.11 Duct smoke detectors. *Smoke detectors installed in ducts shall be listed for the air velocity, temperature and humidity present in the duct.* Duct smoke detectors shall be connected to the building’s fire alarm control unit when a fire alarm system is provided. Activation of a duct smoke detector shall initiate a visible and audible supervisory signal at a constantly attended location and shall perform the intended fire safety function in accordance with this code and with the California Mechanical Code. Duct smoke detectors shall not be used as a substitute for required open-area detection.

Exceptions:

1. The supervisory signal at a constantly attended location is not required where duct smoke detectors activate the building’s alarm notification appliances.

2. In occupancies not required to be equipped with a fire alarm system, actuation of a smoke detector shall activate a visible and audible signal in an approved location. Smoke detector trouble conditions shall activate a visible or audible signal in an approved location and shall be identified as air duct detector trouble.

[F] 907.12 Access. Access shall be provided to each detector for periodic inspection, maintenance and testing.

[F] 907.13 Fire-extinguishing systems. Automatic fire-extinguishing systems shall be connected to the building fire alarm system where a fire alarm system is required by another section of this code or is otherwise installed.

[F] 907.14 Monitoring. Fire alarm systems required by this chapter or the California Fire Code shall be monitored by an approved supervising station in accordance with NFPA 72.

Exception: Supervisory service is not required for:

1. Single- and multiple-station smoke alarms required by Section 907.2.10.
2. Group I-3 occupancies shall be monitored in accordance with Section 907.2.6.3.
3. Automatic sprinkler systems in one- and two-family dwellings.

[F] 907.15 Automatic telephone-dialing devices. Automatic telephone-dialing devices used to transmit an emergency alarm shall not be connected to any fire department telephone number unless approved by the fire chief.

907.16 Acceptance tests. Upon completion of the installation of the fire alarm system, alarm notification appliances and circuits, alarm-initiating devices and circuits, supervisory-signal initiating devices and circuits, signaling line circuits, primary and secondary power supplies, fire safety function control devices and interfaces, and off-site monitoring equipment shall be tested in accordance with NFPA 72.

[F] 907.17 Record of completion. A record of completion in accordance with NFPA 72 verifying that the system has been installed in accordance with the approved plans and specifications shall be provided.

[F] 907.18 Instructions. Operating, testing and maintenance instructions, and record drawings (“as built”) and equipment specifications shall be provided at an approved location.

[F] 907.19 Inspection, testing and maintenance. The maintenance and testing schedules and procedures for fire alarm and fire detection systems shall be in accordance with the California Fire Code.

**SECTION 908
EMERGENCY ALARM SYSTEMS**

[F] 908.1 Group H occupancies. Emergency alarms for the detection and notification of an emergency condition in Group H occupancies shall be provided in accordance with Section 414.7.

[F] 908.2 Group H-5 occupancy. Emergency alarms for notification of an emergency condition in an HPM facility shall be provided as required in Section 415.8.4.6. A continuous

been fully complied with and that the fire department has received satisfactory instruction on the operation, both automatic and manual, of the system.

Exception: In buildings of phased construction, a temporary certificate of occupancy, as approved by the fire code official, shall be allowed provided that those portions of the building to be occupied meet the requirements of this section and that the remainder does not pose a significant hazard to the safety of the proposed occupants or adjacent buildings.

909.20 Smokeproof enclosures. Where required by Section 1020.1.7, a smokeproof enclosure shall be constructed in accordance with this section. A smokeproof enclosure shall consist of an enclosed interior exit stairway that conforms to Section 1020.1 and an open exterior balcony or ventilated vestibule meeting the requirements of this section. Where access to the roof is required by the *California Fire Code*, such access shall be from the smokeproof enclosure where a smokeproof enclosure is required.

909.20.1 Access. Access to the stair shall be by way of a vestibule or an open exterior balcony. The minimum dimension of the vestibule shall not be less than the required width of the corridor leading to the vestibule but shall not have a width of less than 44 inches (1118 mm) and shall not have a length of less than 72 inches (1829 mm) in the direction of egress travel.

909.20.2 Construction. The smokeproof enclosure shall be separated from the remainder of the building by not less than a 2-hour fire barrier without openings other than the required means of egress doors. The vestibule shall be separated from the stairway by not less than a 2-hour fire barrier. The open exterior balcony shall be constructed in accordance with the fire-resistance-rating requirements for floor construction.

909.20.2.1 Vestibule doors. *The door assembly from the building into the vestibule shall be a 90-minute fire door assembly complying with Section 715.4.4. The door assembly from the vestibule to the stairway shall not have less than a 20-minute fire protection rating and complying with the requirements for a smoke door assembly in accordance with Section 715.4.3. The door shall be installed in accordance with NFPA 105.*

909.20.2.2 Door closers. Doors in a smokeproof enclosure shall be self- or automatic closing by actuation of a smoke detector in accordance with Section 715.4 and shall be installed at the floor-side entrance to the smokeproof enclosure. The actuation of the smoke detector on any door shall activate the closing devices on all doors in the smokeproof enclosure at all levels. Smoke detectors shall be installed in accordance with Section 907.10.

909.20.2.3 Standpipes. *Fire department standpipe connections and valves serving the floor shall be within the vestibule and located in such a manner so as not to*

obstruct egress where hose lines are connected and charged.

909.20.2.4 Pressure differences. *The minimum pressure differences within the vestibule with the doors closed shall be 0.05-inch water gage (12.44 Pa) positive pressure relative to the fire floor and 0.05-inch water gage (12.44 Pa) negative pressure relative to the exit enclosure. No pressure difference is required relative to a nonfire floor.*

909.20.3 Natural ventilation alternative. The provisions of Sections 909.20.4.1 and 909.20.4.2 shall apply to ventilation of smokeproof enclosures by natural means.

909.20.3.1 Balcony doors. Where access to the stairway is by way of an open exterior balcony, the door assembly into the enclosure shall be a fire door assembly in accordance with Section 715.4.

909.20.3.2 Vestibule ventilation. Each vestibule shall have a minimum net area of 16 square feet (1.5 m²) of opening in a wall facing an outer court, yard or public way that is at least 20 feet (6096 mm) in width.

909.20.4 Ventilating equipment. The activation of ventilating equipment required by Sections 909.20.3 shall be by smoke detectors installed at each floor level at an approved location at the entrance to the smokeproof enclosure *and upon activation of the automatic controls required by Section 909.12.3.* When the closing device for the stair shaft and vestibule doors is activated by smoke detection or power failure, the mechanical equipment shall activate and operate at the required performance levels. Smoke detectors shall be installed in accordance with Section 907.10.

909.20.4.1 Ventilation systems. Smokeproof enclosure ventilation systems shall be independent of other building ventilation systems. The equipment and ductwork shall comply with one of the following:

1. Equipment and ductwork shall be located exterior to the building and directly connected to the smokeproof enclosure or connected to the smokeproof enclosure by ductwork enclosed by 2-hour fire barriers.
2. Equipment and ductwork shall be located within the smokeproof enclosure with intake or exhaust directly from and to the outside or through ductwork enclosed by 2-hour fire barriers.
3. Equipment and ductwork shall be located within the building if separated from the remainder of the building, including other mechanical equipment, by 2-hour fire barriers.

SECTION 910 SMOKE AND HEAT VENTS

[F] 910.1 General. Where required by this code or otherwise installed, smoke and heat vents, or mechanical smoke exhaust

systems, and draft curtains shall conform to the requirements of this section.

Exceptions:

1. Frozen food warehouses used solely for storage of Class I and II commodities where protected by an approved automatic sprinkler system.
2. Where areas of buildings are equipped with early suppression fast-response (ESFR) sprinklers, automatic smoke and heat vents shall not be required within these areas. *This exception shall not apply to any state institution or other state-owned or state-occupied buildings or other applications listed in Section 111 regulated by the Office of the State Fire Marshal.*

[F] 910.2 Where required. Smoke and heat vents shall be installed in the roofs of one-story buildings or portions thereof occupied for the uses set forth in Sections 910.2.1 through 910.2.3.

[F] 910.2.1 Group F-1 or S-1. Buildings and portions thereof used as a Group F-1 or S-1 occupancy having more than 50,000 square feet (4645 m²) in undivided area.

Exception: Group S-1 aircraft repair hangars.

[F] 910.2.2 High-piled combustible storage. Buildings and portions thereof containing high-piled combustible stock or rack storage in any occupancy group in accordance with Section 413 and the *California Fire Code*.

[F] 910.2.3 Exit access travel distance increase. Buildings and portions thereof used as a Group F-1 or S-1 occupancy

where the maximum exit access travel distance is increased in accordance with Section 1016.2.

[F] 910.3 Design and installation. The design and installation of smoke and heat vents and draft curtains shall be as specified in Sections 910.3.1 through 910.3.5.2 and Table 910.3.

[F] 910.3.1 Design. Smoke and heat vents shall be listed and labeled to indicate compliance with *FM 4430, ICC ES AC 331, or UL 793*.

[F] 910.3.2 Vent operation. Smoke and heat vents shall be capable of being operated by approved automatic and manual means. Automatic operation of smoke and heat vents shall conform to the provisions of Sections 910.3.2.1 through 910.3.2.3.

[F] 910.3.2.1 Gravity-operated drop-out vents. Automatic smoke and heat vents containing heat-sensitive glazing designed to shrink and drop out of the vent opening when exposed to fire shall fully open within 5 minutes after the vent cavity is exposed to a simulated fire, represented by a time-temperature gradient that reaches an air temperature of 500°F (260°C) within 5 minutes.

[F] 910.3.2.2 Sprinklered buildings. Where installed in buildings provided with an approved automatic sprinkler system, smoke and heat vents shall be designed to operate automatically.

[F] 910.3.2.3 Nonsprinklered buildings. Where installed in buildings not provided with an approved

**[F] TABLE 910.3
REQUIREMENTS FOR DRAFT CURTAINS AND SMOKE AND HEAT VENTS^a**

OCCUPANCY GROUP AND COMMODITY CLASSIFICATION	DESIGNATED STORAGE HEIGHT (feet)	MINIMUM DRAFT CURTAIN DEPTH (feet)	MAXIMUM AREA FORMED BY DRAFT CURTAINS (square feet)	VENT-AREA-TO-FLOOR-AREA RATIO ^c	MAXIMUM SPACING OF VENT CENTERS (feet)	MAXIMUM DISTANCE TO VENTS FROM WALL OR DRAFT CURTAINS ^b (feet)
Group F-1 and S-1	—	0.2 × H ^d but ≥ 4	50,000	1:100	120	60
High-piled Storage (see Section 910.2.2) I-IV (Option 1)	≤ 20	6	10,000	1:100	100	60
	> 20 ≤ 40	6	8,000	1:75	100	55
High-piled Storage (see Section 910.2.2) I-IV (Option 2)	≤ 20	4	3,000	1:75	100	55
	> 20 ≤ 40	4	3,000	1:50	100	50
High-piled Storage (see Section 910.2.2) High hazard (Option 1)	≤ 20	6	6,000	1:50	100	50
	> 20 ≤ 30	6	6,000	1:40	90	45
High-piled Storage (see Section 910.2.2) High hazard (Option 2)	≤ 20	4	4,000	1:50	100	50
	> 20 ≤ 30	4	2,000	1:30	75	40

For SI: 1 foot = 304.8 mm, 1 square foot = 0.0929 m².

- a. Requirements for rack storage heights in excess of those indicated shall be in accordance with Chapter 23 of the *California Fire Code*. For solid-piled storage heights in excess of those indicated, an approved engineered design shall be used.
- b. The distance specified is the maximum distance from any vent in a particular draft curtained area to walls or draft curtains which form the perimeter of the draft curtained area.
- c. Where draft curtains are not required, the vent-area-to-floor-area ratio shall be calculated based on a minimum draft curtain depth of 6 feet (Option 1).
- d. "H" is the height of the vent, in feet, above the floor.

**CALIFORNIA BUILDING CODE – MATRIX ADOPTION TABLE
CHAPTER 10 – MEANS OF EGRESS**

Adopting Agency	BSC	SFM	HCD			DSA		OSHPD				CSA	DHS	AGR	DWR	CEC	CA	SL	SLC
			1	2	1/AC	AC	SS	1	2	3	4								
Adopt Entire Chapter	X						X ◆												
Adopt Entire Chapter as amended (amended sections listed below)		X	X ◆	X ◆					X	X	X	X							
Adopt only those sections that are listed below						X	X												
Chapter / Section	Codes																		
1002	CA	X																	
Accessible Means of Egress	IBC						X												
Area of Refuge	IBC						X												
Exit	IBC						X												
Guard (or Guardrail)	CA		X	X			X												
Handrail	IBC						X												
Photo Luminescent	CA	X																	
Self-Luminous	CA	X																	
Public Way	IBC						X												
Stair	IBC						X												
Stairway	IBC						X												
1003.1	CA	X	X	X	X														
1003.1.1	CA								X	X									
1003.1.1.1	CA								X										
1003.1.1.2	CA									X									
1003.2	CA	X																	
1003.3 Exc.	CA	X																	
1003.3.3.1	CA	X																	
1003.5	CA	X																	
Table 1004.1.1	CA	X																	
Table 1005.1	CA	X																	
1006.1	CA	X																	
1007.1	CA	X				X	X												
1007.2	CA					X	X												
1007.3	CA					X	X												
1007.4	IBC						X												
1007.5	CA					X	X												
1007.5.1	IBC						X												
1007.6	CA						X												
1007.6.1	CA		X	X	X	X													
1007.6.2	IBC						X												
1007.6.3.1	CA					X	X												
1007.6.4	CA						X												
1007.6.5	CA					X	X												
1007.7	CA					X	X												

CHAPTER 10 – MEANS OF EGRESS (Continued)

Adopting Agency	BSC	SFM	HCD			DSA		OSHPD				CSA	DHS	AGR	DWR	CEC	CA	SL	SLC
			1	2	1/AC	AC	SS	1	2	3	4								
Adopt Entire Chapter	X						X ◆												
Adopt Entire Chapter as amended (amended sections listed below)		X	X ◆	X ◆					X	X	X	X							
Adopt only those sections that are listed below						X	X												
Chapter / Section	Codes																		
1007.8	IBC						X												
1007.9	CA		X	X	X	X	X												
1008-1 st paragraph only	CA						X												
1008.1.1	CA		X	X	X	X													
1008.1.1.1 Exc.	CA		X																
1008.1.2	CA		X																
1008.1.3.4	CA		X																
1008.1.4	IBC			X	X														
1008.1.6	IBC			X	X	X													
1008.1.7	IBC			X	X	X													
1008.1.8.6	CA		X																
1008.1.8.6-Item 5.1 only	CA						X												
1008.1.9	CA		X																
1009-1 st paragraph only	CA						X												
1009.1	CA		X																
1009.3	IBC			X	X														
1009.4	CA		X																
1009.4	IBC			X	X														
1009.10	CA		X	X	X														
1009.10-last paragraph	CA						X												
1010-1 st paragraph only	CA						X												
1010.6.5	CA					X													
1010.9	CA					X													
1011.1	CA		X																
1011.3	CA		X				X												
1011.6	CA		X																
1011.7	CA		X																
1012-1 st paragraph only	CA						X												
1012.7	CA		X																
1013.1	IBC						X												
1013.2	IBC						X												
1013.3	CA		X	X	X	X	X												

CHAPTER 10 – MEANS OF EGRESS (Continued)

Adopting Agency	BSC	SFM	HCD			DSA		OSHPD				CSA	DHS	AGR	DWR	CEC	CA	SL	SLC
			1	2	1/AC	AC	SS	1	2	3	4								
Adopt Entire Chapter	X						X ◆												
Adopt Entire Chapter as amended (amended sections listed below)		X	X ◆	X ◆					X	X	X	X							
Adopt only those sections that are listed below						X	X												
Chapter / Section	Codes																		
1014.2	CA		X																
1014.2.2	CA		X																
1014.2.2.1	CA		X																
1014.4 (last paragraph only)	CA						X												
1014.4.1 Exc. only	CA						X												
1015.1	CA		X																
1015.5	IBC		X	X	X	X			X	X	X	X							
1015.7	CA		X																
Table 1016.1	CA		X																
Table 1017.1	CA		X																
1017.2	CA		X																
1017.4	CA		X						X	X	X	X							
1017.4.1	CA		X						X	X	X	X							
1017.4.1	IBC			X	X														
1017.5	CA		X																
Table 1019.2	CA		X																
1020.1 Item 6	CA		X																
1020.1.6.1	CA		X																
1020.1.6.2	CA		X					X											
1020.1.7	CA		X																
1020.1.7.1	CA		X																
1020.1.7.2	CA		X																
1021.2	CA		X																
1022.5	CA		X																
1023.2	CA		X																
1024.6	CA		X																
1025.1	CA		X																
1025.2	CA		X																
1025.3	CA		X																
1025.3.1	CA		X																
1025.6.1	CA		X																
1025.6.4	CA		X																
1025.9.1 Item 6	CA		X																
1025.10 Exc.	CA		X																
1026.4	CA		X																

The ◆ designation indicates that the Office of the State Fire Marshal's adoption of this chapter or individual sections is applicable to structures subject to HCD 1 and/or HCD 2 or DSA-SS.

unit of area as prescribed in Table 1004.1.1. For areas without fixed seating, the occupant load shall not be less than that number determined by dividing the floor area under consideration by the occupant per unit of area factor assigned to the occupancy as set forth in Table 1004.1.1. Where an intended use is not listed in Table 1004.1.1, the building official shall establish a use based on a listed use that most nearly resembles the intended use.

Exception: Where approved by the building official, the actual number of occupants for whom each occupied space, floor or building is designed, although less than those determined by calculation, shall be permitted to be used in the determination of the design occupant load.

1004.2 Increased occupant load. The occupant load permitted in any building, or portion thereof, is permitted to be increased from that number established for the occupancies in Table 1004.1.1, provided that all other requirements of the code are also met based on such modified number and the occupant load does not exceed one occupant per 7 square feet (0.65 m²) of occupiable floor space. Where required by the building official, an approved aisle, seating or fixed equipment diagram substantiating any increase in occupant load shall be submitted. Where required by the building official, such diagram shall be posted.

1004.3 Posting of occupant load. Every room or space that is an assembly occupancy shall have the occupant load of the room or space posted in a conspicuous place, near the main exit or exit access doorway from the room or space. Posted signs shall be of an approved legible permanent design and shall be maintained by the owner or authorized agent.

1004.4 Exiting from multiple levels. Where exits serve more than one floor, only the occupant load of each floor considered individually shall be used in computing the required capacity of the exits at that floor, provided that the exit capacity shall not decrease in the direction of egress travel.

1004.5 Egress convergence. Where means of egress from floors above and below converge at an intermediate level, the capacity of the means of egress from the point of convergence shall not be less than the sum of the two floors.

1004.6 Mezzanine levels. The occupant load of a mezzanine level with egress onto a room or area below shall be added to that room or area's occupant load, and the capacity of the exits shall be designed for the total occupant load thus established.

1004.7 Fixed seating. For areas having fixed seats and aisles, the occupant load shall be determined by the number of fixed seats installed therein. The occupant load for areas in which fixed seating is not installed, such as waiting spaces and wheelchair spaces, shall be determined in accordance with Section 1004.1.1 and added to the number of fixed seats.

For areas having fixed seating without dividing arms, the occupant load shall not be less than the number of seats based on one person for each 18 inches (457 mm) of seating length.

The occupant load of seating booths shall be based on one person for each 24 inches (610 mm) of booth seat length measured at the backrest of the seating booth.

**TABLE 1004.1.1
MAXIMUM FLOOR AREA ALLOWANCES PER OCCUPANT**

FUNCTION OF SPACE	FLOOR AREA IN SQ. FT. PER OCCUPANT
Accessory storage areas, mechanical equipment room	300 gross
Agricultural building	300 gross
Aircraft hangars	500 gross
Airport terminal	
Baggage claim	20 gross
Baggage handling	300 gross
Concourse	100 gross
Waiting areas	15 gross
Assembly	
Gaming floors (keno, slots, etc.)	11 gross
Assembly with fixed seats	See Section 1004.7
Assembly without fixed seats	
Concentrated (chairs only-not fixed)	7 net
Standing space	5 net
Unconcentrated (tables and chairs)	15 net
Bowling centers, allow 5 persons for each lane including 15 feet of runway, and for additional areas	7 net
Business areas	100 gross
Courtrooms-other than fixed seating areas	40 net
Day care	35 net
Dormitories	50 gross
Educational	
Classroom area	20 net
Shops and other vocational room areas	50 net
Exercise rooms	50 gross
H-5 Fabrication and manufacturing areas	200 gross
Industrial areas	100 gross
Institutional areas	
Inpatient treatment areas	240 gross
Outpatient areas	100 gross
Sleeping areas	120 gross
Kitchens, commercial	200 gross
Laboratory	
Educational	50 net
Laboratories, noneducational	100 net
Laboratory suite ^a	200 gross
Library	
Reading rooms	50 net
Stack area	100 gross
Locker rooms	50 gross
Mercantile	
Areas on other floors	60 gross
Basement and grade floor areas	30 gross
Storage, stock, shipping areas	300 gross
Parking garages	200 gross
Residential	200 gross
Skating rinks, swimming pools	
Rink and pool	50 gross
Decks	15 gross
Stages and platforms	15 net
Warehouses	500 gross

For SI: 1 square foot = 0.0929 m².

^aSee Section 443.2.

1004.8 Outdoor areas. Yards, patios, courts and similar outdoor areas accessible to and usable by the building occupants shall be provided with means of egress as required by this chapter. The occupant load of such outdoor areas shall be assigned by the building official in accordance with the anticipated use. Where outdoor areas are to be used by persons in addition to the occupants of the building, and the path of egress travel from the outdoor areas passes through the building, means of egress requirements for the building shall be based on the sum of the occupant loads of the building plus the outdoor areas.

Exceptions:

1. Outdoor areas used exclusively for service of the building need only have one means of egress.
2. Both outdoor areas associated with Group R-3 and individual dwelling units of Group R-2.

1004.9 Multiple occupancies. Where a building contains two or more occupancies, the means of egress requirements shall apply to each portion of the building based on the occupancy of that space. Where two or more occupancies utilize portions of the same means of egress system, those egress components shall meet the more stringent requirements of all occupancies that are served.

**SECTION 1005
EGRESS WIDTH**

1005.1 Minimum required egress width. The means of egress width shall not be less than required by this section. The total width of means of egress in inches (mm) shall not be less than the total occupant load served by the means of egress multiplied by the factors in Table 1005.1 and not less than specified elsewhere in this code. Multiple means of egress shall be sized such that the loss of any one means of egress shall not reduce the available capacity to less than 50 percent of the required capacity. The maximum capacity required from any story of a building shall be maintained to the termination of the means of egress.

Exception: Means of egress complying with Section 1025.

**TABLE 1005.1
EGRESS WIDTH PER OCCUPANT SERVED**

OCCUPANCY	WITHOUT SPRINKLER SYSTEM		WITH SPRINKLER SYSTEM ^a	
	Stairways (inches per occupant)	Other egress components (inches per occupant)	Stairways (inches per occupant)	Other egress components (inches per occupant)
Occupancies other than those listed below ^b	0.3	0.2	0.2	0.15
Hazardous: H-1, H-2, H-3 and H-4	NA	NA	0.7	0.4
Institutional: I-2	NA	NA	0.3	0.2

For SI: 1 inch = 25.4 mm. NA = Not applicable.

a. Buildings equipped throughout with an automatic sprinkler system in accordance with Section 903.3.1.1 or 903.3.1.2.

b. See Section 1025.

1005.2 Door encroachment. Doors opening into the path of egress travel shall not reduce the required width to less than one-half during the course of the swing. When fully open, the door shall not project more than 7 inches (178 mm) into the required width.

Exception: The restrictions on a door swing shall not apply to doors within individual dwelling units and sleeping units of Group R-2 and dwelling units of Group R-3.

**SECTION 1006
MEANS OF EGRESS ILLUMINATION**

1006.1 Illumination required. The means of egress, including the exit discharge, shall be illuminated at all times the building space served by the means of egress is occupied.

Exceptions:

1. Occupancies in Group U.
2. Aisle access ways in Group A.
3. Dwelling units and sleeping units in Groups R-1, R-2 and R-3.
4. Sleeping units of Group I occupancies and Group R-4.

1006.2 Illumination level. The means of egress illumination level shall not be less than 1 foot-candle (11 lux) at the walking surface level.

Exception: For auditoriums, theaters, concert or opera halls and similar assembly occupancies, the illumination at the walking surface is permitted to be reduced during performances to not less than 0.2 foot-candle (2.15 lux), provided that the required illumination is automatically restored upon activation of a premises' fire alarm system where such system is provided.

1006.3 Illumination emergency power. The power supply for means of egress illumination shall normally be provided by the premises' electrical supply.

In the event of power supply failure, an emergency electrical system shall automatically illuminate the following areas:

1. Aisles and unenclosed egress stairways in rooms and spaces that require two or more means of egress.
2. Corridors, exit enclosures and exit passageways in buildings required to have two or more exits.
3. Exterior egress components at other than the level of exit discharge until exit discharge is accomplished for buildings required to have two or more exits.
4. Interior exit discharge elements, as permitted in Section 1024.1, in buildings required to have two or more exits.
5. Exterior landings, as required by Section 1008.1.5, for exit discharge doorways in buildings required to have two or more exits.

The emergency power system shall provide power for a duration of not less than 90 minutes and shall consist of storage batteries, unit equipment or an on-site generator. The installation of the emergency power system shall be in accordance with Section 2702.

1006.4 Performance of system. Emergency lighting facilities shall be arranged to provide initial illumination that is at least an average of 1 foot-candle (11 lux) and a minimum at any point of 0.1 foot-candle (1 lux) measured along the path of egress at floor level. Illumination levels shall be permitted to decline to 0.6 foot-candle (6 lux) average and a minimum at any point of 0.06 foot-candle (0.6 lux) at the end of the emergency lighting time duration. A maximum-to-minimum illumination uniformity ratio of 40 to 1 shall not be exceeded.

SECTION 1007 ACCESSIBLE MEANS OF EGRESS

1007.1 Accessible means of egress required. Accessible means of egress shall comply with this section. Accessible spaces shall be provided with not less than one accessible means of egress. Where more than one means of egress is required by Sections 1015.1 or 1019.1 from any accessible space, each accessible portion of the space shall be served by accessible means of egress *in at least the same number as required by Section 1015.1 or 1019.1. In addition to the requirements of this chapter, means of egress, which provide access to, or egress from, buildings for persons with disabilities, shall also comply with the requirements of Chapter 11A or 11B, as applicable.*

Exceptions:

1. Accessible means of egress are not required in alterations to existing buildings.
2. One accessible means of egress is required from an accessible mezzanine level in accordance with Section 1007.3, 1007.4 or 1007.5 and Chapter 11A or 11B, as applicable.
3. In assembly spaces with sloped floors, one accessible means of egress is required from a space where the common path of travel of the accessible route for access to the wheelchair spaces meets the requirements in Section 1025.8 and Chapter 11A or 11B, as applicable.

1007.2 Continuity and components. Each required accessible means of egress shall be continuous to a public way and shall consist of one or more of the following components:

1. Accessible routes complying with Chapter 11A, Sections 1110A.1 and 1120A, or Chapter 11B, Section 1114B.1.2, as applicable.
2. Stairways within vertical exit enclosures complying with Sections 1007.3, 1020 and Chapter 11A, Section 1123A, or Chapter 11B, Section 1133B.4, as applicable.
3. Exterior exit stairways complying with Sections 1007.3, 1023 and Chapter 11A, Section 1115A, or Chapter 11B, Section 1133B.4, as applicable.
4. Elevators complying with Section 1007.4 and Chapter 11A, Section 1124A, or Chapter 11B, Section 1116B.1, as applicable.
5. Platform lifts complying with Section 1007.5 and Chapter 11A, Section 1124A, or Chapter 11B, Sections 1116B.2 and 1116B.3, as applicable.
6. Horizontal exits complying with Section 1022.

7. Ramps complying with Section 1010 and Chapter 11A, Sections 1114A and 1122A, or Chapter 11B, Section 1133B.5, as applicable.
8. Areas of refuge complying with Section 1007.6.

Exceptions:

1. Where the exit discharge is not accessible, an exterior area for assisted rescue must be provided in accordance with Section 1007.8.
2. Where the exit stairway is open to the exterior, the accessible means of egress shall include either an area of refuge in accordance with Section 1007.6 or an exterior area for assisted rescue in accordance with Section 1007.8.

1007.2.1 Elevators required. In buildings where a required accessible floor is four or more stories above or below a level of exit discharge, at least one required accessible means of egress shall be an elevator complying with Section 1007.4.

Exceptions:

1. In buildings equipped throughout with an automatic sprinkler system installed in accordance with Section 903.3.1.1 or 903.3.1.2, the elevator shall not be required on floors provided with a horizontal exit and located at or above the level of exit discharge.
2. In buildings equipped throughout with an automatic sprinkler system installed in accordance with Section 903.3.1.1 or 903.3.1.2, the elevator shall not be required on floors provided with a ramp conforming to the provisions of Section 1010.

1007.3 Exit stairways. In order to be considered part of an accessible means of egress, an exit stairway shall have a clear width of 48 inches (1219 mm) minimum between handrails and shall either incorporate an area of refuge within an enlarged floor-level landing or shall be accessed from either an area of refuge complying with Section 1007.6 or a horizontal exit. *[DSA-AC & HCD 1-AC] In addition, exit stairways shall comply with Chapter 11A, Sections 1115A and 1123A, or Chapter 11B, Section 1133B.4, as applicable.*

Exceptions:

1. Unenclosed exit stairways as permitted by Section 1020.1 are permitted to be considered part of an accessible means of egress.
2. The area of refuge is not required at unenclosed exit stairways as permitted by Section 1020.1 in buildings or facilities that are equipped throughout with an automatic sprinkler system installed in accordance with Section 903.3.1.1.
3. The clear width of 48 inches (1219 mm) between handrails is not required at exit stairways in buildings or facilities equipped throughout with an automatic sprinkler system installed in accordance with Section 903.3.1.1 or 903.3.1.2.

4. The clear width of 48 inches (1219 mm) between handrails is not required for exit stairways accessed from a horizontal exit.
5. Areas of refuge are not required at exit stairways serving open parking garages.

1007.4 Elevators. In order to be considered part of an accessible means of egress, an elevator shall comply with the emergency operation and signaling device requirements of Section 2.27 of ASME A17.1. Standby power shall be provided in accordance with Sections 2702 and 3003. The elevator shall be accessed from either an area of refuge complying with Section 1007.6 or a horizontal exit.

Exception: Elevators are not required to be accessed from an area of refuge or horizontal exit in open parking garages.

1007.5 Platform lifts. Platform (wheelchair) lifts shall not serve as part of an accessible means of egress, except where allowed as part of a required accessible route in *Chapter 11A, Section 1121A, or Chapter 11B, Sections 1116B.2.1 through 1116B.2.4, as applicable.* Standby power shall be provided in accordance with Section 2702.2.6 for platform lifts permitted to serve as part of a means of egress.

[DSA-AC] See Chapter 11B, Section 1116B.3 for additional accessible means of egress requirements at platform (wheelchair) lifts.

1007.5.1 Openness. Platform lifts on an accessible means of egress shall not be installed in a fully enclosed hoistway.

1007.6 Areas of refuge. Every required area of refuge shall be accessible from the space it serves by an accessible means of egress. The maximum travel distance from any accessible space to an area of refuge shall not exceed the travel distance permitted for the occupancy in accordance with Section 1016.1. Every required area of refuge shall have direct access to an enclosed stairway complying with Sections 1007.3 and 1020.1 or an elevator complying with Section 1007.4. Where an elevator lobby is used as an area of refuge, the shaft and lobby shall comply with Section 1020.1.7 for smokeproof enclosures except where the elevators are in an area of refuge formed by a horizontal exit or smoke barrier. [DSA-AC] *Areas of refuge shall comply with the requirements of this code and shall adjoin an accessible route of travel complying with Section 1114B.1.2.*

1007.6.1 Size. Each area of refuge shall be sized to accommodate two wheelchair spaces that are not less than 30 inches by 48 inches (762 mm by 1219 mm) each. The total number of such 30-inch by 48-inch (762 mm by 1219 mm) spaces per story shall be not less than one for every 200 persons of calculated occupant load served by the area of refuge. Such wheelchair spaces shall not reduce the required means of egress width. Access to any of the required wheelchair spaces in an area of refuge shall not be obstructed by more than one adjoining wheelchair space.

Exception: The enforcing agency may reduce the size of each required area of refuge to accommodate one wheelchair space that is not less than 30 inches by 48 inches (762 mm by 1219 mm) on floors where the occupant load is less than 200.

1007.6.2 Separation. Each area of refuge shall be separated from the remainder of the story by a smoke barrier complying with Section 709 of the *California Building Code* or a horizontal exit complying with Section 1022. Each area of refuge shall be designed to minimize the intrusion of smoke.

Exception: Areas of refuge located within a vertical exit enclosure.

1007.6.3 Two-way communication. Areas of refuge shall be provided with a two-way communication system between the area of refuge and a central control point. If the central control point is not constantly attended, the area of refuge shall also have controlled access to a public telephone system. Location of the central control point shall be approved by the fire department. The two-way communication system shall include both audible and visible signals.

1007.6.3.1 Visible communication method. [DSA-AC & HCD 1-AC] *A button complying with Section 1117B.6 in the area of refuge shall activate both a light in the area of refuge indicating that rescue has been requested and a light at the central control point indicating that rescue is being requested. A button at the central control point shall activate both a light at the central control point and a light in the area of refuge indicating that the request has been received.*

1007.6.4 Instructions. In areas of refuge that have a two-way emergency communications system, instructions on the use of the area under emergency conditions shall be posted adjoining the communications system. The instructions shall include all of the following and shall comply with Section 1117B.5.1, Item 2:

1. Directions to find other means of egress.
2. Persons able to use the exit stairway do so as soon as possible, unless they are assisting others.
3. Information on planned availability of assistance in the use of stairs or supervised operation of elevators and how to summon such assistance.
4. Directions for use of the emergency communications system.

1007.6.5 Identification. Each door providing access to an area of refuge from an adjacent floor area shall be identified by a sign complying with Section 1117B.5.1, Item 2, stating: AREA OF REFUGE, and including the International Symbol of Accessibility. Where exit sign illumination is required by Section 1011.2, the area of refuge sign shall be illuminated. Additionally, tactile signage complying with Section 1117B.5.1, Item 1 shall be located at each door to an area of refuge.

1007.7 Signage. At exits and elevators serving a required accessible space but not providing an approved accessible means of egress, signage shall be installed indicating the location of accessible means of egress. [DSA-AC & HCD 1-AC] *Signs shall comply with Chapter 11A or Chapter 11B, Section 1117B.5.1, Items 2 and 3, as applicable.*

1007.8 Exterior area for assisted rescue. The exterior area for assisted rescue must be open to the outside air and meet the requirements of Section 1007.6.1. Separation walls shall com-

ply with the requirements of Section 704 for exterior walls. Where walls or openings are between the area for assisted rescue and the interior of the building, the building exterior walls within 10 feet (3048 mm) horizontally of a nonrated wall or unprotected opening shall have a fire-resistance rating of not less than 1 hour. Openings within such exterior walls shall be protected by opening protectives having a fire protection rating of not less than $\frac{3}{4}$ hour. This construction shall extend vertically from the ground to a point 10 feet (3048 mm) above the floor level of the area for assisted rescue or to the roof line, whichever is lower.

1007.8.1 Openness. The exterior area for assisted rescue shall be at least 50 percent open, and the open area above the guards shall be so distributed as to minimize the accumulation of smoke or toxic gases.

1007.8.2 Exterior exit stairway. Exterior exit stairways that are part of the means of egress for the exterior area for assisted rescue shall provide a clear width of 48 inches (1219 mm) between handrails.

1007.8.3 Identification. Exterior areas for assisted rescue shall have identification as required for area of refuge that complies with Section 1007.6.5.

1007.9 Alarms/emergency warning systems/accessibility. *If emergency warning systems are required, they shall activate a means of warning the hearing impaired. Emergency warning systems as part of the fire-alarm system shall be designed and installed in accordance with NFPA 72 as amended in Chapter 35.*

SECTION 1008 DOORS, GATES AND TURNSTILES

[DSA-AC] In addition to the requirements of this section, means of egress, which provide access to, or egress from, buildings or facilities where accessibility is required for applications listed in Section 109.1 regulated by the Division of the State Architect—Access Compliance, shall also comply with Chapter 11A or Chapter 11B, Section 1133B.2, as applicable.

1008.1 Doors. Means of egress doors shall meet the requirements of this section. Doors serving a means of egress system shall meet the requirements of this section and Section 1018.2. Doors provided for egress purposes in numbers greater than required by this code shall meet the requirements of this section.

Means of egress doors shall be readily distinguishable from the adjacent construction and finishes such that the doors are easily recognizable as doors. Mirrors or similar reflecting materials shall not be used on means of egress doors. Means of egress doors shall not be concealed by curtains, drapes, decorations or similar materials.

1008.1.1 Size of doors. The minimum width of each door opening shall be sufficient for the occupant load thereof and shall provide a clear width of not less than 32 inches (813 mm). Clear openings of doorways with swinging doors shall be measured between the face of the door and the stop, with the door open 90 degrees (1.57 rad). Where this section requires a minimum clear width of 32 inches (813 mm) and

a door opening includes two door leaves without a mullion, one leaf shall provide a clear opening width of 32 inches (813 mm). The maximum width of a swinging door leaf shall be 48 inches (1219 mm) nominal. Means of egress doors in a Group I-2 occupancy used for the movement of beds *and litter patients* shall provide a clear width not less than 44 inches (1118 mm). The height of doors shall not be less than 80 inches (2032 mm).

Exceptions:

1. The minimum and maximum width shall not apply to door openings that are not part of the required means of egress in Group R-2 and R-3 occupancies.
2. *Other than those required to be accessible by Chapter 11B*, door openings to resident sleeping units in Group 1-3 occupancies shall have a clear width of not less than 28 inches (711 mm).
3. Door openings to storage closets less than 10 square feet (0.93 m²) in area shall not be limited by the minimum width.
4. Width of door leaves in revolving doors that comply with Section 1008.1.3.1 shall not be limited.
5. Door openings within a dwelling unit or sleeping unit shall not be less than 78 inches (1981 mm) in height.
6. Exterior door openings in dwelling units and sleeping units, other than the required exit door, shall not be less than 76 inches (1930 mm) in height.
7. In other than Group R-1 occupancies, the minimum widths shall not apply to interior egress doors within a dwelling unit or sleeping unit that is not required to be *adaptable or accessible as specified in Chapter 11A or 11B, as applicable.*
8. Door openings required to be accessible within dwelling units shall have a minimum clear width as *specified in Chapter 11A or 11B, as applicable.*

1008.1.1.1 Projections into clear width. There shall not be projections into the required clear width lower than 34 inches (864 mm) above the floor or ground. Projections into the clear opening width between 34 inches (864 mm) and 80 inches (2032 mm) above the floor or ground shall not exceed 4 inches (102 mm).

Exception: *In a Group I-2 occupancy, there shall be no projections into the clear width of doors used for the movement of beds and litter patients in the means of egress.*

1008.1.2 Door swing. Egress doors shall be side-hinged swinging.

Exceptions:

1. Private garages, office areas, factory and storage areas with an occupant load of 10 or less.
2. Group I-3 occupancies used as a place of detention.

3. Critical or intensive care patient rooms within suites of health care facilities.
4. Doors within or serving a single dwelling unit in Groups R-2 and R-3.
5. In other than Group H occupancies, revolving doors complying with Section 1008.1.3.1.
6. In other than Group H occupancies, horizontal sliding doors complying with Section 1008.1.3.3 are permitted in a means of egress.
7. Power-operated doors in accordance with Section 1008.1.3.2.
8. Doors serving a bathroom within an individual sleeping unit in Group R-1.
9. *In I-2 and I-2.1 occupancies, exit doors serving an occupant load of 10 or more may be of the pivoted or balanced type.*

Doors shall swing in the direction of egress travel where serving an occupant load of 50 or more persons or a Group H occupancy. For Group L occupancies see Section 442.6.3.

In a Group I-2 occupancy, all required exterior egress doors shall open in the direction of egress regardless of the occupant load served.

The opening force for interior side-swinging doors without closers shall not exceed a 5-pound (22 N) force. For other side-swinging, sliding and folding doors, the door latch shall release when subjected to a 15-pound (67 N) force. The door shall be set in motion when subjected to a 30-pound (133 N) force. The door shall swing to a full-open position when subjected to a 15-pound (67 N) force. Forces shall be applied to the latch side.

1008.1.3 Special doors. Special doors and security grilles shall comply with the requirements of Sections 1008.1.3.1 through 1008.1.3.5.

1008.1.3.1 Revolving doors. Revolving doors shall comply with the following:

1. Each revolving door shall be capable of collapsing into a bookfold position with parallel egress paths providing an aggregate width of 36 inches (914 mm).
2. A revolving door shall not be located within 10 feet (3048 mm) of the foot of or top of stairs or escalators. A dispersal area shall be provided between the stairs or escalators and the revolving doors.
3. The revolutions per minute (rpm) for a revolving door shall not exceed those shown in Table 1008.1.3.1.
4. Each revolving door shall have a side-hinged swinging door which complies with Section 1008.1 in the same wall and within 10 feet (3048 mm) of the revolving door.

**TABLE 1008.1.3.1
REVOLVING DOOR SPEEDS**

INSIDE DIAMETER (feet-inches)	POWER-DRIVEN-TYPE SPEED CONTROL (rpm)	MANUAL-TYPE SPEED CONTROL (rpm)
6-6	11	12
7-0	10	11
7-6	9	11
8-0	9	10
8-6	8	9
9-0	8	9
9-6	7	8
10-0	7	8

For SI: 1 inch = 25.4 mm, 1 foot = 304.8 mm.

1008.1.3.1.1 Egress component. A revolving door used as a component of a means of egress shall comply with Section 1008.1.3.1 and the following three conditions:

1. Revolving doors shall not be given credit for more than 50 percent of the required egress capacity.
2. Each revolving door shall be credited with no more than a 50-person capacity.
3. Each revolving door shall be capable of being collapsed when a force of not more than 130 pounds (578 N) is applied within 3 inches (76 mm) of the outer edge of a wing.

1008.1.3.1.2 Other than egress component. A revolving door used as other than a component of a means of egress shall comply with Section 1008.1.3.1. The collapsing force of a revolving door not used as a component of a means of egress shall not be more than 180 pounds (801 N).

Exception: A collapsing force in excess of 180 pounds (801 N) is permitted if the collapsing force is reduced to not more than 130 pounds (578 N) when at least one of the following conditions is satisfied:

1. There is a power failure or power is removed to the device holding the door wings in position.
2. There is an actuation of the automatic sprinkler system where such system is provided.
3. There is an actuation of a smoke detection system which is installed in accordance with Section 907 to provide coverage in areas within the building which are within 75 feet (22 860 mm) of the revolving doors.

stating: THIS DOOR TO REMAIN UNLOCKED WHEN BUILDING IS OCCUPIED. The sign shall be in letters 1 inch (25 mm) high on a contrasting background,

- 2.3. The use of the key-operated locking device is revokable by the building official for due cause.
3. Where egress doors are used in pairs, approved automatic flush bolts shall be permitted to be used, provided that the door leaf having the automatic flush bolts has no doorknob or surface-mounted hardware.
4. Doors from individual dwelling or sleeping units of Group R occupancies having an occupant load of 10 or less are permitted to be equipped with a night latch, dead bolt or security chain, provided such devices are openable from the inside without the use of a key or tool.

1008.1.8.4 Bolt locks. Manually operated flush bolts or surface bolts are not permitted.

Exceptions:

1. On doors not required for egress in individual dwelling units or sleeping units.
2. Where a pair of doors serves a storage or equipment room, manually operated edge- or surface-mounted bolts are permitted on the inactive leaf.

1008.1.8.5 Unlatching. The unlatching of any door or leaf shall not require more than one operation.

Exceptions:

1. Places of detention or restraint.
2. Where manually operated bolt locks are permitted by Section 1008.1.8.4.
3. Doors with automatic flush bolts as permitted by Section 1008.1.8.3, Exception 3.
4. Doors from individual dwelling units and sleeping units of Group R occupancies as permitted by Section 1008.1.8.3, Exception 4.

1008.1.8.6 Delayed egress locks. Approved, listed, delayed egress locks shall be permitted to be installed on doors serving any occupancy except Group A, E, H and L occupancies in buildings that are equipped throughout with an automatic sprinkler system in accordance with Section 903.3.1.1 and an approved automatic smoke detection system installed in accordance with Section 907, provided that the doors unlock in accordance with Items 1 through 9 below. A building occupant shall not be required to pass through more than one door equipped with a delayed egress lock before entering an exit. *Delayed egress devices shall conform to all of the following:*

1. The doors unlock upon actuation of the automatic sprinkler system or automatic *smoke* detection system.

2. The doors unlock upon loss of *electrical power* to any one of the following:

2.1 *The egress-control device itself.*

2.2 *The smoke detection system.*

2.3 *Means of egress illumination as required by Section 1006.*

3. The door locks shall have the capability of being unlocked by a signal from a switch located in an approved location.
4. The initiation of an irreversible process which will release the latch in not more than 15 seconds when a force of not more than 15 pounds (67 N) is applied for 1 second to the release device. Initiation of the irreversible process shall activate an audible signal in the vicinity of the door. Once the door lock has been released by the application of force to the releasing device, relocking shall be by manual means only. *[SFM] The time delay established for each egress-control device shall not be field adjustable. For applications listed in Section 109.1 regulated by the Division of the State Architect—Access Compliance, see Chapter 11B, Section 1133B.2.5.*

Exception: *In facilities housing Alzheimer's or dementia clients, a delay of not more than 30 seconds is permitted.*

5. A sign shall be provided on the door located above and within 12 inches (305 mm) of the release device reading: "KEEP PUSHING. THIS DOOR WILL OPEN IN 15 [30] SECONDS. ALARM WILL SOUND." Sign lettering shall be at least 1 inch (25 mm) in height and shall have a stroke of not less than $\frac{1}{8}$ inch (3.2 mm).
 - 5.1 *A tactile sign shall also be provided in Braille and raised characters, which complies with Section 1117B.5.1, Item 1.*
6. Emergency lighting shall be provided at the door.
7. *Actuation of the panic bar or other door-latching hardware shall activate an audible signal at the door.*
8. *The unlatching shall not require more than one operation.*
9. *Regardless of the means of deactivation, relocking of the egress-control device shall be by manual means only at the door.*

1008.1.8.7 Stairway doors. Interior stairway means of egress doors shall be openable from both sides without the use of a key or special knowledge or effort.

Exceptions:

1. Stairway discharge doors shall be openable from the egress side and shall only be locked from the opposite side.

2. This section shall not apply to doors arranged in accordance with Section 403.12.
3. In stairways serving not more than four stories, doors are permitted to be locked from the side opposite the egress side, provided they are openable from the egress side and capable of being unlocked simultaneously without unlatching upon a signal from the fire command center, if present, or a signal by emergency personnel from a single location inside the main entrance to the building.

1008.1.9 Panic and fire exit hardware. Where panic and fire exit hardware is installed, it shall comply with the following:

1. The actuating portion of the releasing device shall extend at least one-half of the door leaf width.
2. The maximum unlatching force shall not exceed 15 pounds (67 N).

Each door in a means of egress from a Group A, or *assembly area not classified as an assembly occupancy*, E, I-2 or I-2.1 occupancies having an occupant load of 50 or more and any Group H occupancy shall not be provided with a latch or lock unless it is panic hardware or fire exit hardware. *For Group L occupancies, see Section 443.6.4.*

Exception: A main exit of a Group A occupancy in compliance with Section 1008.1.8.3, Item 2.

Electrical rooms with equipment rated 1,200 amperes or more and over 6 feet (1829 mm) wide that contain overcurrent devices, switching devices or control devices with exit access doors shall be equipped with panic hardware and doors shall swing in the direction of egress.

If balanced doors are used and panic hardware is required, the panic hardware shall be the push-pad type and the pad shall not extend more than one-half the width of the door measured from the latch side.

1008.2 Gates. Gates serving the means of egress system shall comply with the requirements of this section. Gates used as a component in a means of egress shall conform to the applicable requirements for doors.

Exception: Horizontal sliding or swinging gates exceeding the 4-foot (1219 mm) maximum leaf width limitation are permitted in fences and walls surrounding a stadium.

1008.2.1 Stadiums. Panic hardware is not required on gates surrounding stadiums where such gates are under constant immediate supervision while the public is present, and where safe dispersal areas based on 3 square feet (0.28 m²) per occupant are located between the fence and enclosed space. Such required safe dispersal areas shall not be located less than 50 feet (15 240 mm) from the enclosed space. See Section 1024.6 for means of egress from safe dispersal areas.

1008.3 Turnstiles. Turnstiles or similar devices that restrict travel to one direction shall not be placed so as to obstruct any required means of egress.

Exception: Each turnstile or similar device shall be credited with no more than a 50-person capacity where all of the following provisions are met:

1. Each device shall turn free in the direction of egress travel when primary power is lost, and upon the manual release by an employee in the area.
2. Such devices are not given credit for more than 50 percent of the required egress capacity.
3. Each device is not more than 39 inches (991 mm) high.
4. Each device has at least 16.5 inches (419 mm) clear width at and below a height of 39 inches (991 mm) and at least 22 inches (559 mm) clear width at heights above 39 inches (991 mm).

Where located as part of an accessible route, turnstiles shall have at least 36 inches (914 mm) clear at and below a height of 34 inches (864 mm), at least 32 inches (813 mm) clear width between 34 inches (864 mm) and 80 inches (2032 mm) and shall consist of a mechanism other than a revolving device.

1008.3.1 High turnstile. Turnstiles more than 39 inches (991 mm) high shall meet the requirements for revolving doors.

1008.3.2 Additional door. Where serving an occupant load greater than 300, each turnstile that is not portable shall have a side-hinged swinging door which conforms to Section 1008.1 within 50 feet (15 240 mm).

SECTION 1009 STAIRWAYS

[DSA-AC] In addition to the requirements of this section, means of egress, which provide access to, or egress from, buildings or facilities where accessibility is required for applications listed in Section 109.1 regulated by the Division of the State Architect—Access Compliance, shall also comply with Chapter 11A or Chapter 11B, Section 1133B.4, as applicable.

1009.1 Stairway width. The width of stairways shall be determined as specified in Section 1005.1, but such width shall not be less than 44 inches (1118 mm). See Section 1007.3 for accessible means of egress stairways.

Exceptions:

1. Stairways serving an occupant load of less than 50 shall have a width of not less than 36 inches (914 mm).
2. Spiral stairways as provided for in Section 1009.8.
3. Aisle stairs complying with Section 1025.
4. Where an incline platform lift or stairway chairlift is installed on stairways serving occupancies in Group

1011.5 Externally illuminated exit signs. Externally illuminated exit signs shall comply with Sections 1011.5.1 through 1011.5.3.

1011.5.1 Graphics. Every exit sign and directional exit sign shall have plainly legible letters not less than 6 inches (152 mm) high with the principal strokes of the letters not less than 0.75 inch (19.1 mm) wide. The word “EXIT” shall have letters having a width not less than 2 inches (51 mm) wide, except the letter “I,” and the minimum spacing between letters shall not be less than 0.375 inch (9.5 mm). Signs larger than the minimum established in this section shall have letter widths, strokes and spacing in proportion to their height.

The word “EXIT” shall be in high contrast with the background and shall be clearly discernible when the means of exit sign illumination is or is not energized. If a chevron directional indicator is provided as part of the exit sign, the construction shall be such that the direction of the chevron directional indicator cannot be readily changed.

1011.5.2 Exit sign illumination. The face of an exit sign illuminated from an external source shall have an intensity of not less than 5 foot-candles (54 lux).

1011.5.3 Power source. Exit signs shall be illuminated at all times. To ensure continued illumination for a duration of not less than 90 minutes in case of primary power loss, the sign illumination means shall be connected to an emergency power system provided from storage batteries, unit equipment or an on-site generator. The installation of the emergency power system shall be in accordance with Section 2702.

Exception: Approved exit sign illumination means that provide continuous illumination independent of external power sources for a duration of not less than 90 minutes, in case of primary power loss, are not required to be connected to an emergency electrical system.

1011.6 Floor-level exit signs. *Where exit signs are required by Chapter 10, additional approved low-level exit signs, which are internally or externally illuminated photoluminescent or self-luminous, shall be provided in all interior corridors of Group A occupancies, Group I occupancies and in all interior rated exit corridors serving guest rooms of hotels in Group R, Division 1 occupancies.*

Exceptions:

1. *Group A occupancies that are protected throughout by an approved supervised fire sprinkler system.*
2. *Group I occupancies which are provided with smoke barriers constructed in accordance with Section 407.4.*
3. *Group I, Division 3 occupancies.*

The bottom of the sign shall not be less than 6 inches (152 mm) or more than 8 inches (203 mm) above the floor level and shall indicate the path of exit travel. For exit and exit-access doors, the sign shall be on the door or adjacent to the door with the closest edge of the sign or marker within 4 inches (102 mm) of the door frame.

Note: Pursuant to Health and Safety Code Section 13143, this California amendment applies to all newly constructed buildings or structures subject to this section for which a building permit is issued (or construction commenced, where no building permit is issued) on or after January 1, 1989.

1011.7 Path marking. *When exit signs are required by Chapter 10, in addition to approved floor-level exit signs, approved path marking shall be installed at floor level or no higher than 8 inches (203 mm) above the floor level in all interior rated exit corridors of unsprinklered Group A occupancies, and Groups R-1 and R-2 occupancies.*

Such marking shall be continuous except as interrupted by doorways, corridors or other such architectural features in order to provide a visible delineation along the path of travel.

Note: Pursuant to Health and Safety Code Section 13143, the California amendments of this section shall apply to all newly constructed buildings or structures subject to this section for which a building permit is issued (or construction commenced, where no building permit is issued) on or after January 1, 1989.

SECTION 1012 HANDRAILS

[DSA-AC] In addition to the requirements of this section, means of egress, which provide access to, or egress from, buildings or facilities where accessibility is required for applications listed in Section 109.1 regulated by the Division of the State Architect—Access Compliance, shall also comply with Chapter 11A or Chapter 11B, Sections 1133B.4.1 or 1133B.5.5, as applicable.

1012.1 Where required. Handrails for stairways and ramps shall be adequate in strength and attachment in accordance with Section 1607.7. Handrails required for stairways by Section 1009.10 shall comply with Sections 1012.2 through 1012.8. Handrails required for ramps by Section 1010.8 shall comply with Sections 1012.2 through 1012.7.

1012.2 Height. Handrail height, measured above stair tread nosings, or finish surface of ramp slope shall be uniform, not less than 34 inches (864 mm) and not more than 38 inches (965 mm).

1012.3 Handrail graspability. Handrails with a circular cross-section shall have an outside diameter of at least 1.25 inches (32 mm) and not greater than 2 inches (51 mm) or shall provide equivalent graspability. If the handrail is not circular, it shall have a perimeter dimension of at least 4 inches (102 mm) and not greater than 6.25 inches (160 mm) with a maximum cross-section dimension of 2.25 inches (57 mm). Edges shall have a minimum radius of 0.01 inch (0.25 mm).

1012.4 Continuity. Handrail-gripping surfaces shall be continuous, without interruption by newel posts or other obstructions.

Exceptions:

1. Handrails within dwelling units are permitted to be interrupted by a newel post at a stair or ramp landing.

2. Within a dwelling unit, the use of a volute, turnout or starting easing is allowed on the lowest tread.
3. Handrail brackets or balusters attached to the bottom surface of the handrail that do not project horizontally beyond the sides of the handrail within 1.5 inches (38 mm) of the bottom of the handrail shall not be considered obstructions. For each 0.5 inch (12.7 mm) of additional handrail perimeter dimension above 4 inches (102 mm), the vertical clearance dimension of 1.5 inches (38 mm) shall be permitted to be reduced by 0.125 inch (3 mm).

1012.5 Handrail extensions. Handrails shall return to a wall, guard or the walking surface or shall be continuous to the handrail of an adjacent stair flight or ramp run. At stairways where handrails are not continuous between flights, the handrails shall extend horizontally at least 12 inches (305 mm) beyond the top riser and continue to slope for the depth of one tread beyond the bottom riser. At ramps where handrails are not continuous between runs, the handrails shall extend horizontally above the landing 12 inches (305 mm) minimum beyond the top and bottom of ramp runs.

Exceptions:

1. Handrails within a dwelling unit that is not required to be accessible need extend only from the top riser to the bottom riser.
2. Aisle handrails in Group A occupancies in accordance with Section 1025.13.

1012.6 Clearance. Clear space between a handrail and a wall or other surface shall be a minimum of 1.5 inches (38 mm). A handrail and a wall or other surface adjacent to the handrail shall be free of any sharp or abrasive elements.

1012.7 Projections. On ramps, the clear width between handrails shall be 36 inches (914 mm) minimum. Projections into the required width of stairways and ramps at each handrail shall not exceed 4.5 inches (114 mm) at or below the handrail height. Projections into the required width shall not be limited above the minimum headroom height required in Section 1009.2.

In Group I-2 occupancy, on ramps and stairways used for the movement of bed and litter patients, the clear width between handrails shall be 44 inches (1118 mm) minimum.

1012.8 Intermediate handrails. Stairways shall have intermediate handrails located in such a manner that all portions of the stairway width required for egress capacity are within 30 inches (762 mm) of a handrail. On monumental stairs, handrails shall be located along the most direct path of egress travel.

SECTION 1013 GUARDS

1013.1 Where required. Guards shall be located along open-sided walking surfaces, mezzanines, industrial equipment platforms, stairways, ramps and landings that are located more than 30 inches (762 mm) above the floor or grade below. Guards shall be adequate in strength and attachment in accordance with Section 1607.7. Where glass is used to provide a guard or as a portion of the guard system, the guard shall also comply with Section 2407. Guards shall also be located along

glazed sides of stairways, ramps and landings that are located more than 30 inches (762 mm) above the floor or grade below where the glazing provided does not meet the strength and attachment requirements in Section 1607.7.

Exception: Guards are not required for the following locations:

1. On the loading side of loading docks or piers.
2. On the audience side of stages and raised platforms, including steps leading up to the stage and raised platforms.
3. On raised stage and platform floor areas, such as runways, ramps and side stages used for entertainment or presentations.
4. At vertical openings in the performance area of stages and platforms.
5. At elevated walking surfaces appurtenant to stages and platforms for access to and utilization of special lighting or equipment.
6. Along vehicle service pits not accessible to the public.
7. In assembly seating where guards in accordance with Section 1025.14 are permitted and provided.

1013.2 Height. Guards shall form a protective barrier not less than 42 inches (1067 mm) high, measured vertically above the leading edge of the tread, adjacent walking surface or adjacent seatboard.

Exceptions:

1. For occupancies in Group R-3, and within individual dwelling units in occupancies in Group R-2, guards whose top rail also serves as a handrail shall have a height not less than 34 inches (864 mm) and not more than 38 inches (965 mm) measured vertically from the leading edge of the stair tread nosing.
2. The height in assembly seating areas shall be in accordance with Section 1025.14.

1013.3 Opening limitations. Open guards shall have balusters or ornamental patterns such that a 4-inch-diameter (102 mm) sphere cannot pass through any opening.

Exceptions:

1. The triangular openings formed by the riser, tread and bottom rail at the open side of a stairway shall be of a maximum size such that a sphere of 6 inches (152 mm) in diameter cannot pass through the opening.
2. At elevated walking surfaces for access to and use of electrical, mechanical or plumbing systems or equipment, guards shall have balusters or be of solid materials such that a sphere with a diameter of 21 inches (533 mm) cannot pass through any opening.
3. In areas that are not open to the public within occupancies in Group I-3, F, H or S, balusters, horizontal intermediate rails or other construction shall not permit a sphere with a diameter of 21 inches (533 mm) to pass through any opening.
4. In assembly seating areas, guards at the end of aisles where they terminate at a fascia of boxes, balconies and galleries shall have balusters or ornamental pat-

1014.4.3.1 Aisle accessway for tables and seating. Aisle accessways serving arrangements of seating at tables or counters shall have sufficient clear width to conform to the capacity requirements of Section 1005.1 but shall not have less than the appropriate minimum clear width specified in Section 1014.4.3.2.

1014.4.3.2 Table and seating accessway width. Aisle accessways shall provide a minimum of 12 inches (305 mm) of width plus 0.5 inch (12.7 mm) of width for each additional 1 foot (305 mm), or fraction thereof, beyond 12 feet (3658 mm) of aisle accessway length measured from the center of the seat farthest from an aisle.

Exception: Portions of an aisle accessway having a length not exceeding 6 feet (1829 mm) and used by a total of not more than four persons.

1014.4.3.3 Table and seating aisle accessway length. The length of travel along the aisle accessway shall not exceed 30 feet (9144 mm) from any seat to the point where a person has a choice of two or more paths of egress travel to separate exits.

1014.5 Egress balconies. Balconies used for egress purposes shall conform to the same requirements as corridors for width, headroom, dead ends and projections.

1014.5.1 Wall separation. Exterior egress balconies shall be separated from the interior of the building by walls and opening protectives as required for corridors.

Exception: Separation is not required where the exterior egress balcony is served by at least two stairs and a dead-end travel condition does not require travel past an unprotected opening to reach a stair.

1014.5.2 Openness. The long side of an egress balcony shall be at least 50 percent open, and the open area above the guards shall be so distributed as to minimize the accumulation of smoke or toxic gases.

**SECTION 1015
EXIT AND EXIT ACCESS DOORWAYS**

1015.1 Exit or exit access doorways required. Two exits or exit access doorways from any space shall be provided where one of the following conditions exists:

1. The occupant load of the space exceeds the values in Table 1015.1.
2. The common path of egress travel exceeds the limitations of Section 1014.3.
3. Where required by Sections 1015.3, 1015.4 and 1015.5.
4. *In detention and correctional facilities and holding cells, such as are found in courthouse buildings, a minimum of two means of egress shall be provided when the occupant load is more than 20.*

Exception: Group I-2 occupancies shall comply with Section 1014.2.2.

1015.1.1 Three or more exits. Access to three or more exits shall be provided from a floor area where required by Section 1019.1.

**TABLE 1015.1
SPACES WITH ONE MEANS OF EGRESS**

OCCUPANCY	MAXIMUM OCCUPANT LOAD
A, B, E ^a , F, M, U	49
H-1, H-2, H-3	3
H-4, H-5, I-1, I-3, I-4, R	10
S	29
L	See Section 443.6.1

a. Day care maximum occupant load is 10.

1015.2 Exit or exit access doorway arrangement. Required exits shall be located in a manner that makes their availability obvious. Exits shall be unobstructed at all times. Exit and exit access doorways shall be arranged in accordance with Sections 1015.2.1 and 1015.2.2.

1015.2.1 Two exits or exit access doorways. Where two exits or exit access doorways are required from any portion of the exit access, the exit doors or exit access doorways shall be placed a distance apart equal to not less than one-half of the length of the maximum overall diagonal dimension of the building or area to be served measured in a straight line between exit doors or exit access doorways. Interlocking or scissor stairs shall be counted as one exit stairway.

Exceptions:

1. Where exit enclosures are provided as a portion of the required exit and are interconnected by a 1-hour fire-resistance-rated corridor conforming to the requirements of Section 1017, the required exit separation shall be measured along the shortest direct line of travel within the corridor.
2. Where a building is equipped throughout with an automatic sprinkler system in accordance with Section 903.3.1.1 or 903.3.1.2, the separation distance of the exit doors or exit access doorways shall not be less than one-third of the length of the maximum overall diagonal dimension of the area served.

1015.2.2 Three or more exits or exit access doorways. Where access to three or more exits is required, at least two exit doors or exit access doorways shall be arranged in accordance with the provisions of Section 1015.2.1.

1015.3 Boiler, incinerator and furnace rooms. Two exit access doorways are required in boiler, incinerator and furnace rooms where the area is over 500 square feet (46 m²) and any fuel-fired equipment exceeds 400,000 British thermal units (Btu) (422 000 KJ) input capacity. Where two exit access doorways are required, one is permitted to be a fixed ladder or an alternating tread device. Exit access doorways shall be separated by a horizontal distance equal to one-half the length of the maximum overall diagonal dimension of the room.

1015.4 Refrigeration machinery rooms. Machinery rooms larger than 1,000 square feet (93 m²) shall have not less than two exits or exit access doors. Where two exit access doorways are required, one such doorway is permitted to be served by a fixed ladder or an alternating tread device. Exit access door-

ways shall be separated by a horizontal distance equal to one-half the maximum horizontal dimension of room.

All portions of machinery rooms shall be within 150 feet (45 720 mm) of an exit or exit access doorway. An increase in travel distance is permitted in accordance with Section 1016.1.

Doors shall swing in the direction of egress travel, regardless of the occupant load served. Doors shall be tight fitting and self-closing.

1015.5 Refrigerated rooms or spaces. Rooms or spaces having a floor area of 1,000 square feet (93 m²) or more, containing a refrigerant evaporator and maintained at a temperature below 68°F (20°C), shall have access to not less than two exits or exit access doors.

Travel distance shall be determined as specified in Section 1016.1, but all portions of a refrigerated room or space shall be within 150 feet (45 720 mm) of an exit or exit access door where such rooms are not protected by an approved automatic sprinkler system. Egress is allowed through adjoining refrigerated rooms or spaces.

Exception: Where using refrigerants in quantities limited to the amounts based on the volume set forth in the *California Mechanical Code*.

1015.6 Stage means of egress. Where two means of egress are required, based on the stage size or occupant load, one means of egress shall be provided on each side of the stage.

1015.6.1 Gallery, gridiron and catwalk means of egress. The means of egress from lighting and access catwalks, galleries and gridirons shall meet the requirements for occupancies in Group F-2.

Exceptions:

1. A minimum width of 22 inches (559 mm) is permitted for lighting and access catwalks.
2. Spiral stairs are permitted in the means of egress.
3. Stairways required by this subsection need not be enclosed.
4. Stairways with a minimum width of 22 inches (559 mm), ladders, or spiral stairs are permitted in the means of egress.
5. A second means of egress is not required from these areas where a means of escape to a floor or to a roof is provided. Ladders, alternating tread devices or spiral stairs are permitted in the means of escape.
6. Ladders are permitted in the means of egress.

1015.7 Large-family day care home. Every story or basement of a large-family day care home shall be provided with two exits which are remotely located from each other. Every required exit shall be of a size to permit the installation of a door not less than 32 inches (813 mm) in clear width and not less than 6 feet 8 inches (2032 mm) in height. A manually operated horizontal sliding door may be used as one of the two required exits.

Where basements are used for day care purposes, one of the two required exits shall provide access directly to the exterior without entering the first story. The second exit from the base-

ment may either pass through the story above or exit directly to the exterior.

Rooms used for day care purposes shall not be located above the first story.

Exception: Buildings equipped with an automatic sprinkler system throughout and which have at least one of the required exits providing access directly to the exterior. NFPA 13R may be used in large-family day care homes. The sprinkler omissions of NFPA 13R shall not apply unless approved by the authority having jurisdiction.

Exit doors, including manually operated horizontal sliding doors, shall be openable from the inside without use of a key or any special knowledge or effort.

Tables 1019.1 and 1019.2 are not applicable to this occupancy classification.

SECTION 1016 EXIT ACCESS TRAVEL DISTANCE

1016.1 Travel distance limitations. Exits shall be so located on each story such that the maximum length of exit access travel, measured from the most remote point within a story to the entrance to an exit along the natural and unobstructed path of egress travel, shall not exceed the distances given in Table 1016.1.

Where the path of exit access includes unenclosed stairways or ramps within the exit access or includes unenclosed exit ramps or stairways as permitted in Section 1020.1, the distance of travel on such means of egress components shall also be included in the travel distance measurement. The measurement along stairways shall be made on a plane parallel and tangent to the stair tread nosings in the center of the stairway.

Exceptions:

1. Travel distance in open parking garages is permitted to be measured to the closest riser of open stairs.
2. In outdoor facilities with open exit access components and open exterior stairs or ramps, travel distance is permitted to be measured to the closest riser of a stair or the closest slope of the ramp.
3. Where an exit stair is permitted to be unenclosed in accordance with Exception 8 or 9 of Section 1020.1, the travel distance shall be measured from the most remote point within a building to an exit discharge.

1016.2 Roof vent increase. In buildings that are one story in height, equipped with automatic heat and smoke roof vents complying with Section 910 and equipped throughout with an automatic sprinkler system in accordance with Section 903.3.1.1, the maximum exit access travel distance shall be 400 feet (122 m) for occupancies in Group F-1 or S-1.

1016.3 Exterior egress balcony increase. Travel distances specified in Section 1016.1 shall be increased up to an additional 100 feet (30 480 mm) provided the last portion of the exit access leading to the exit occurs on an exterior egress balcony constructed in accordance with Section 1014.5. The length of such balcony shall not be less than the amount of the increase taken.

**TABLE 1016.1
EXIT ACCESS TRAVEL DISTANCE^a**

OCCUPANCY	WITHOUT SPRINKLER SYSTEM (feet)	WITH SPRINKLER SYSTEM (feet)
A, E, F-1, I-1, M, R, S-1	200	250 ^b
B	200	300 ^c
F-2, S-2, U	300	400 ^c
H-1	Not Permitted	75 ^c
H-2	Not Permitted	100 ^c
H-3	Not Permitted	150 ^c
H-4	Not Permitted	175 ^c
H-5	Not Permitted	200 ^c
I-2, I-3 ^d , I-4	150	200 ^c
L	Not Permitted	200 ^c

For SI: 1 foot = 304.8 mm.

- a. See the following sections for modifications to exit access travel distance requirements:
 Section 402: For the distance limitation in malls.
 Section 404: For the distance limitation through an atrium space.
 Section 1016.2 For increased limitations in Groups F-1 and S-1.
 Section 1025.7: For increased limitation in assembly seating.
 Section 1025.7: For increased limitation for assembly open-air seating.
 Section 1019.2: For buildings with one exit.
 Chapter 31: For the limitation in temporary structures.
- b. Buildings equipped throughout with an automatic sprinkler system in accordance with Section 903.3.1.1 or 903.3.1.2. See Section 903 for occupancies where automatic sprinkler systems in accordance with Section 903.3.1.2 are permitted.
- c. Buildings equipped throughout with an automatic sprinkler system in accordance with Section 903.3.1.1.
- d. Not permitted in nonsprinklered Group I-3 occupancies.

**SECTION 1017
CORRIDORS**

1017.1 Construction. Corridors shall be fire-resistance rated in accordance with Table 1017.1. The corridor walls required

to be fire-resistance rated shall comply with Section 708 for fire partitions.

Exceptions:

1. A fire-resistance rating is not required for corridors in an occupancy in Group E where each room that is used for instruction has at least one door directly to the exterior and rooms for assembly purposes have at least one-half of the required means of egress doors opening directly to the exterior. Exterior doors specified in this exception are required to be at ground level.
2. A fire-resistance rating is not required for corridors contained within a dwelling or sleeping unit in an occupancy in Group R.
3. A fire-resistance rating is not required for corridors in open parking garages.
4. A fire-resistance rating is not required for corridors in an occupancy in Group B which is a space requiring only a single means of egress complying with Section 1015.1.

1017.2 Corridor width. The minimum corridor width shall be as determined in Section 1005.1, but not less than 44 inches (1118 mm).

Exceptions:

1. Twenty-four inches (610 mm)—For access to and utilization of electrical, mechanical or plumbing systems or equipment.
2. Thirty-six inches (914 mm)—With a required occupancy capacity of less than 50.
3. Thirty-six inches (914 mm)—Within a dwelling unit.
4. Seventy-two inches (1829 mm)—In Group E with a corridor having a required capacity of 100 or more.
5. Seventy-two inches (1829 mm)—In corridors serving surgical Group I, health care centers for ambulatory patients receiving outpatient medical care, which causes the patient to be not capable of self-preservation.

**TABLE 1017.1
CORRIDOR FIRE-RESISTANCE RATING**

OCCUPANCY	OCCUPANT LOAD SERVED BY CORRIDOR	REQUIRED FIRE-RESISTANCE RATING (hours)	
		Without sprinkler system	With sprinkler system ^c
H-1, H-2, H-3	All	Not Permitted	1
H-4, H-5, L	Greater than 30	Not Permitted	1
A ^d , B, F, M, S, U	Greater than 30	1	0
R	Greater than 10	Not Permitted	1
I-2 ^a , I-2.1, I-4	Greater than 6	Not Permitted	1
I-1, I-3	Greater than 6	Not Permitted	1 ^b
E	Greater than 10	1	1

- a. For requirements for occupancies in Group I-2, see Section 407.3.
- b. For a reduction in the fire-resistance rating for occupancies in Group I-3, see Section 408.7.
- c. Buildings equipped throughout with an automatic sprinkler system in accordance with Section 903.3.1.1 or 903.3.1.2 where allowed.
- d. [SFM] See Section 1025.

- Ninety-six inches (2438 mm)—In Group I-2 and I-3 occupancies in areas where required for bed movement *or* corridors in Group I-2 and I-3 occupancies serving any area caring for one or more nonambulatory persons.

1017.3 Dead ends. Where more than one exit or exit access doorway is required, the exit access shall be arranged such that there are no dead ends in corridors more than 20 feet (6096 mm) in length.

Exceptions:

- In occupancies in Group I-3 of Occupancy Condition 2, 3 or 4 (see Section 308.4), the dead end in a corridor shall not exceed 50 feet (15 240 mm).
- In occupancies in Groups B and F where the building is equipped throughout with an automatic sprinkler system in accordance with Section 903.3.1.1, the length of dead-end corridors shall not exceed 50 feet (15 240 mm).
- A dead-end corridor shall not be limited in length where the length of the dead-end corridor is less than 2.5 times the least width of the dead-end corridor.

> **1017.4 Air movement in corridors.** Corridors shall not serve as supply, return, exhaust, relief or ventilation air ducts.

Exceptions:

- Use of a corridor as a source of makeup air for exhaust systems in *small rooms of 30 square feet (2.8 m²) or less* that open directly onto such corridors, including toilet rooms, bathrooms, dressing rooms, and janitor closets, shall be permitted, provided that each such corridor is directly supplied with outdoor air at a rate greater than the rate of makeup air taken from the corridor.
- Where located within a dwelling unit, the use of corridors for conveying return air shall not be prohibited.
- Where located within tenant spaces of 1,000 square feet (93 m²) or less in area, utilization of corridors for conveying return air is permitted.
- [OSHPD 1, 2, 3 & 4] *For restrictions on the use of corridors to convey air, see Chapter 4 of the California Mechanical Code.*
- [SFM] *For health care facilities under the jurisdiction of the Office of Statewide Health Planning and Development (OSHPD), see the California Mechanical Code.*

1017.4.1 Corridor ceiling. Use of the space between the corridor ceiling and the floor or roof structure above as a return air plenum is permitted for one or more of the following conditions:

- The corridor is not required to be of fire-resistance-rated construction;
- The corridor is separated from the plenum by fire-resistance-rated construction;

- The air-handling system serving the corridor is shut down upon activation of the air-handling unit smoke detectors required by the *California Mechanical Code*.
- The air-handling system serving the corridor is shut down upon detection of sprinkler waterflow where the building is equipped throughout with an automatic sprinkler system; or
- The space between the corridor ceiling and the floor or roof structure above the corridor is used as a component of an approved engineered smoke control system.

Exception: [OSHPD 1, 2, 3 & 4] For restrictions on the use of the space above a ceiling as a return air plenum, see Chapter 4 of the California Mechanical Code.

1017.5 Corridor continuity. Fire-resistance-rated corridors shall be continuous from the point of entry to an exit, and shall not be interrupted by intervening rooms.

Exceptions:

- Foyers, lobbies or reception rooms constructed as required for corridors shall not be construed as intervening rooms.
- [SFM] *In fully sprinklered office buildings, corridors may lead through enclosed elevator lobbies if all areas of the building have access to at least one required exit without passing through the elevator lobby.*

SECTION 1018 EXITS

1018.1 General. Exits shall comply with Sections 1018 through 1023 and the applicable requirements of Sections 1003 through 1013. An exit shall not be used for any purpose that interferes with its function as a means of egress. Once a given level of exit protection is achieved, such level of protection shall not be reduced until arrival at the exit discharge.

1018.2 Exterior exit doors. Buildings or structures used for human occupancy shall have at least one exterior door that meets the requirements of Section 1008.1.1.

1018.2.1 Detailed requirements. Exterior exit doors shall comply with the applicable requirements of Section 1008.1.

1018.2.2 Arrangement. Exterior exit doors shall lead directly to the exit discharge or the public way.

SECTION 1019 NUMBER OF EXITS AND CONTINUITY

1019.1 Minimum number of exits. All rooms and spaces within each story shall be provided with and have access to the minimum number of approved independent exits required by Table 1019.1 based on the occupant load of the story, except as modified in Section 1015.1 or 1019.2. For the purposes of this chapter, occupied roofs shall be provided with exits as required for stories. The required number of exits from any story, base-

1025.3.1 Occupant loads less than 300. Group A occupancies that have an occupant load of 100 or more and less than 300 shall have at least one of the required means of egress directly to an exit, or through a lobby, that is not used to access the other required exit, to an exit or to a 1-hour-rated corridor to an exit or continuous through a 1-hour-rated lobby to an exit. At least one exit shall discharge on a street or an unoccupied space of not less than 20 feet (6096 mm) in width that adjoins a street or public way.

1025.4 Foyers and lobbies. In Group A-1 occupancies, where persons are admitted to the building at times when seats are not available and are allowed to wait in a lobby or similar space, such use of lobby or similar space shall not encroach upon the required clear width of the means of egress. Such waiting areas shall be separated from the required means of egress by substantial permanent partitions or by fixed rigid railings not less than 42 inches (1067 mm) high. Such foyer, if not directly connected to a public street by all the main entrances or exits, shall have a straight and unobstructed corridor or path of travel to every such main entrance or exit.

1025.5 Interior balcony and gallery means of egress. For balconies or galleries having a seating capacity of 50 or more located in Group A occupancies, at least two means of egress shall be provided, with one from each side of every balcony or gallery and at least one leading directly to an exit.

1025.5.1 Enclosure of balcony openings. Interior stairways and other vertical openings shall be enclosed in an exit enclosure as provided in Section 1020.1, except that stairways are permitted to be open between the balcony and the main assembly floor in occupancies such as theaters, places of religious worship and auditoriums. At least one accessible means of egress is required from a balcony or gallery level containing accessible seating locations in accordance with Section 1007.3 or 1007.4.

1025.6 Width of means of egress for assembly. The clear width of aisles and other means of egress shall comply with Section 1025.6.1 where smoke-protected seating is not provided and with Section 1025.6.2 or 1025.6.3 where smoke-protected seating is provided. The clear width shall be measured to walls, edges of seating and tread edges except for permitted projections.

1025.6.1 Without smoke protection. The clear width of the means of egress shall provide sufficient capacity in accordance with all of the following, as applicable:

1. At least 0.3 inch (7.6 mm) of width for each occupant served shall be provided on stairs having riser heights 7 inches (178 mm) or less and tread depths 11 inches (279 mm) or greater, measured horizontally between tread nosings.
2. At least 0.005 inch (0.127 mm) of additional stair width for each occupant shall be provided for each 0.10 inch (2.5 mm) of riser height above 7 inches (178 mm).
3. Where egress requires stair descent, at least 0.075 inch (1.9 mm) of additional width for each occupant shall be provided on those portions of stair width having no handrail within a horizontal distance of 30 inches (762 mm).
4. Ramped means of egress, where slopes are steeper than one unit vertical in 12 units horizontal (8-percent slope), shall have at least 0.22 inch (5.6 mm) of clear width for each occupant served. Level or ramped means of egress, where slopes are not steeper than one unit vertical in 12 units horizontal (8-percent slope), shall have at least 0.20 inch (5.1 mm) of clear width for each occupant served.
5. Group A occupancies that have an occupant load greater than 300 shall be provided with at least 0.20-inch (5.1 mm) total exit width for each occupant served.

1025.6.2 Smoke-protected seating. The clear width of the means of egress for smoke-protected assembly seating shall not be less than the occupant load served by the egress element multiplied by the appropriate factor in Table 1025.6.2. The total number of seats specified shall be those within the space exposed to the same smoke-protected environment. Interpolation is permitted between the specific values shown. A life safety evaluation, complying with NFPA 101, shall be done for a facility utilizing the reduced width requirements of Table 1025.6.2 for smoke-protected assembly seating.

Exception: For an outdoor smoke-protected assembly with an occupant load not greater than 18,000, the clear

**TABLE 1025.6.2
WIDTH OF AISLES FOR SMOKE-PROTECTED ASSEMBLY**

TOTAL NUMBER OF SEATS IN THE SMOKE-PROTECTED ASSEMBLY OCCUPANCY	INCHES OF CLEAR WIDTH PER SEAT SERVED			
	Stairs and aisle steps with handrails within 30 inches	Stairs and aisle steps without handrails within 30 inches	Passageways, doorways and ramps not steeper than 1 in 10 in slope	Ramps steeper than 1 in 10 in slope
Equal to or less than 5,000	0.200	0.250	0.150	0.165
10,000	0.130	0.163	0.100	0.110
15,000	0.096	0.120	0.070	0.077
20,000	0.076	0.095	0.056	0.062
Equal to or greater than 25,000	0.060	0.075	0.044	0.048

For SI: 1 inch = 25.4 mm.

width shall be determined using the factors in Section 1025.6.3.

1025.6.2.1 Smoke control. Means of egress serving a smoke-protected assembly seating area shall be provided with a smoke control system complying with Section 909 or natural ventilation designed to maintain the smoke level at least 6 feet (1829 mm) above the floor of the means of egress.

1025.6.2.2 Roof height. A smoke-protected assembly seating area with a roof shall have the lowest portion of the roof deck not less than 15 feet (4572 mm) above the highest aisle or aisle accessway.

Exception: A roof canopy in an outdoor stadium shall be permitted to be less than 15 feet (4572 mm) above the highest aisle or aisle accessway provided that there are no objects less than 80 inches (2032 mm) above the highest aisle or aisle accessway.

1025.6.2.3 Automatic sprinklers. Enclosed areas with walls and ceilings in buildings or structures containing smoke-protected assembly seating shall be protected with an approved automatic sprinkler system in accordance with Section 903.3.1.1.

Exceptions:

1. The floor area used for contests, performances or entertainment provided the roof construction is more than 50 feet (15 240 mm) above the floor level and the use is restricted to low fire hazard uses.
2. Press boxes and storage facilities less than 1,000 square feet (93 m²) in area.
3. Outdoor seating facilities where seating and the means of egress in the seating area are essentially open to the outside.

1025.6.3 Width of means of egress for outdoor smoke-protected assembly. The clear width in inches (mm) of aisles and other means of egress shall be not less than the total occupant load served by the egress element multiplied by 0.08 (2.0 mm) where egress is by aisles and stairs and multiplied by 0.06 (1.52 mm) where egress is by ramps, corridors, tunnels or vomitories.

Exception: The clear width in inches (mm) of aisles and other means of egress shall be permitted to comply with Section 1025.6.2 for the number of seats in the outdoor smoke-protected assembly where Section 1025.6.2 permits less width.

1025.6.4 Public address system. See Section 907.2.1.3.

1025.7 Travel distance. Exits and aisles shall be so located that the travel distance to an exit door shall not be greater than 200 feet (60 960 mm) measured along the line of travel in nonsprinklered buildings. Travel distance shall not be more than 250 feet (76 200 mm) in sprinklered buildings. Where aisles are provided for seating, the distance shall be measured

along the aisles and aisle accessway without travel over or on the seats.

Exceptions:

1. Smoke-protected assembly seating: The travel distance from each seat to the nearest entrance to a vomitory or concourse shall not exceed 200 feet (60 960 mm). The travel distance from the entrance to the vomitory or concourse to a stair, ramp or walk on the exterior of the building shall not exceed 200 feet (60 960 mm).
2. Open-air seating: The travel distance from each seat to the building exterior shall not exceed 400 feet (122 m). The travel distance shall not be limited in facilities of Type I or II construction.

1025.8 Common path of egress travel. The common path of egress travel shall not exceed 30 feet (9144 mm) from any seat to a point where an occupant has a choice of two paths of egress travel to two exits.

Exceptions:

1. For areas serving less than 50 occupants, the common path of egress travel shall not exceed 75 feet (22 860 mm).
2. For smoke-protected assembly seating, the common path of egress travel shall not exceed 50 feet (15 240 mm).

1025.8.1 Path through adjacent row. Where one of the two paths of travel is across the aisle through a row of seats to another aisle, there shall be not more than 24 seats between the two aisles, and the minimum clear width between rows for the row between the two aisles shall be 12 inches (305 mm) plus 0.6 inch (15.2 mm) for each additional seat above seven in the row between aisles.

Exception: For smoke-protected assembly seating there shall not be more than 40 seats between the two aisles and the minimum clear width shall be 12 inches (305 mm) plus 0.3 inch (7.6 mm) for each additional seat.

1025.9 Assembly aisles are required. Every occupied portion of any occupancy in Group A that contains seats, tables, displays, similar fixtures or equipment shall be provided with aisles leading to exits or exit access doorways in accordance with this section. Aisle accessways for tables and seating shall comply with Section 1014.4.3.

1025.9.1 Minimum aisle width. The minimum clear width for aisles shall be as shown:

1. Forty-eight inches (1219 mm) for aisle stairs having seating on each side.

Exception: Thirty-six inches (914 mm) where the aisle serves less than 50 seats.

2. Thirty-six inches (914 mm) for aisle stairs having seating on only one side.

CHAPTER 11A

HOUSING ACCESSIBILITY

NOTE: Dwelling units constructed as senior citizen housing may also be subject to the Unruh Civil Rights Act. Refer to Division I, Part 2 of the California Civil Code. For additional information regarding application, interpretation and enforcement, contact the California Department of Fair Employment and Housing.

Division I—APPLICATION, GENERAL PROVISIONS, AND DEFINITIONS

Division I Table of Contents

Section 1101A	Application
Section 1102A	Building Accessibility
Section 1103A	Design and Construction
Section 1104A	Covered Multifamily Dwellings
Section 1105A	Garages, Carports and Parking Facilities
Section 1106A	Site and Building Characteristics
Section 1107A	Definitions

SECTION 1101A APPLICATION

1101A.1 Scope. The application and authority of this chapter are identified and referenced in Sections 108.2.1.2 and 1102A for the Department of Housing and Community Development. Applicable sections are identified in the Matrix Adoption Tables of this code under the abbreviation HCD 1-AC. The provisions of this chapter shall apply to the following:

1. All newly-constructed covered multifamily dwellings.
2. New common use spaces serving existing covered multifamily dwellings.
3. Additions to existing buildings, where the addition alone meets the definition of a covered multifamily dwelling.
4. Common use areas serving covered multifamily dwellings.
5. Where any portion of a building's exterior is preserved, but the interior of the building is removed, including all structural portions of floors and ceilings, the building is considered a new building for determining the application of this chapter.

These building standards generally do not apply to public accommodations such as hotels and motels. Public use areas, public accommodations, and housing which is publicly funded as defined in Chapter 2, Chapter 11A, and Chapter 11B of this code are subject to provisions of the Division of the State Architect (DSA-AC) and are referenced in Section 109.1.1.

SECTION 1102A BUILDING ACCESSIBILITY

1102A.1 Where required. Buildings or portions of buildings and facilities within the scope of this chapter shall be accessible to persons with disabilities. Each building on a building site shall be considered separately when determining the requirements contained in this chapter, except when calculating the number of units which must comply with Section 1102A.3.1.

Dwelling units within a single structure separated by firewalls do not constitute separate buildings.

Newly-constructed covered multifamily dwellings as defined in this chapter, include, but are not limited to, the following:

1. Apartment buildings with 3 or more dwelling units including timeshare apartments not considered a place of public accommodation or transient lodging as defined in Health and Safety Code Section 19955 (a), and Chapter 2 of the California Building Code.
2. Condominiums with 4 or more dwelling units including timeshare condominiums not considered a place of public accommodation or transient lodging as defined in Health and Safety Code Section 19955 (a), and Chapter 2 of the California Building Code.
3. Lodging houses, as defined in Chapter 2 of the California Building Code, used as a residence with more than 3 but not more than 5 guest rooms.
4. Congregate residences, as defined in Chapter 2 of the California Building Code.
5. Dwellings with 3 or more efficiency units, as defined in Chapter 2 of this code, or Section 17958.1 of the California Health and Safety Code.
6. Shelters for homeless persons, not otherwise subject to the disabled access provisions of the Division of the State Architect—Access Compliance (DSA-AC).
7. Dormitories, as defined in Chapter 2 of this code, with 3 or more guest rooms as defined in Chapter 2 of the California Building Code.
8. Timeshare dwellings with 3 or more units, not considered a place of public accommodations or transient lodging as defined in Health and Safety Code Section 19955 (a), and Chapter 2 of the California Building Code.
9. Other Group R occupancies in covered multifamily dwellings which are regulated by the Office of the State Fire Marshal. See Section 111.
10. Housing which is publicly funded as defined in Chapter 2 of this code is subject to provisions of the Division of the State Architect (DSA-AC). See Section 1111.B.5.

1102A.2 Existing buildings. The building standards contained in this chapter do not apply to the alteration, repair, rehabilitation or maintenance of Group R occupancies constructed for first occupancy prior to March 13, 1991. Housing which is publicly funded as defined in Chapter 2 of this code is subject to provisions of the Division of the State Architect (DSA-AC). See Section 1111.B.5.

Covered multifamily dwellings shall be maintained in compliance with the accessibility standards in effect at the time of construction. Apartments constructed prior to March 13, 1991 shall be maintained in compliance with the accessibility standards in effect at the time of construction.

Additions to Group R occupancies shall be subject to the requirements of this chapter, provided the addition, when considered alone, meets the definition of a covered multifamily dwelling, as defined in this chapter. New common use spaces serving existing covered multifamily dwellings shall be subject to the requirements of this chapter.

Note: For all existing public use areas, public accommodations, and housing which is publicly funded, see Chapter 11B, Division IV, Section 1134B for provisions of the Division of the State Architect—Access Compliance (DSA-AC).

1102A.3 Multistory dwellings.

1102A.3.1 Multistory apartment or condominium dwellings in buildings with no elevator. This section shall apply to multistory dwelling units on the ground floor of buildings without elevators for which an application for a construction permit is submitted on or after July 1, 2005.

Exception: Carriage units as defined in Section 1107A.3-C and regulated only by the Department of Housing and Community Development as referenced in Section 108.2.1.2.

At least 10 percent but not less than one of the multistory dwellings in apartment buildings with 3 or more dwelling units and/or condominiums with 4 or more dwelling units shall comply with the following:

1. The primary entry to the dwelling unit shall be on an accessible route unless exempted by site impracticality tests in Section 1150A.
2. At least one powder room or bathroom shall be located on the primary entry level, served by an accessible route and shall comply with the provisions in Division IV.
3. All rooms or spaces located on the primary entry level shall be served by an accessible route and shall comply with the provisions in Division IV. Rooms and spaces located on the primary entry level and subject to this chapter may include but are not limited to kitchens, powder rooms, bathrooms, living rooms, bedrooms, or hallways.
4. Common use areas covered by this section shall be accessible as required by this chapter. Public use areas as defined in Chapter 2, Chapter 11A, and Chapter 11B of this code are subject to provisions of the Division of the State Architect (DSA-AC) and are referenced in Section 109.1.1.

The minimum number of multifamily dwelling units which must comply with this section shall be calculated using the total number of all multistory dwelling units in buildings on a site which are subject to this section. Any fraction thereof shall be rounded to next highest whole number.

1102A.3.2 Multistory dwelling units in buildings with one or more elevators. Multistory dwelling units contained in buildings with elevators shall comply with this section. For multistory dwelling units in buildings with elevators, the story of the unit that is served by the building elevator is considered a ground floor and the primary entry floor to the unit and shall comply with the following:

1. At least 1 powder room or bathroom shall be located on the primary entry level.
2. All rooms or spaces located on the primary entry level shall be served by an accessible route and shall comply with Division IV.

1102A.4 Participation areas. Access shall be provided to elements listed in Section 1104B.4.3, "Participation areas."

1102A.5 Swimming pools. Swimming pools and spas required to be accessible shall comply with the provisions of Section 1141A.

1102A.6 Temporary restrictions. During periods of partial or restricted use of a building or facility, the entrances used for primary access shall be accessible to and usable by persons with disabilities.

SECTION 1103A DESIGN AND CONSTRUCTION

1103A.1 General.

1103A.1.1 When buildings are required to be accessible, they shall be designed and constructed as provided in this chapter.

Note: Public use areas, public accommodations, and housing which is publicly funded as defined in Chapter 2, Chapter 11A, and Chapter 11B of this code are subject to provisions of the Division of the State Architect (DSA-AC) and are referenced in Section 109.1.1.

SECTION 1104A COVERED MULTIFAMILY DWELLINGS

1104A.1 General. All ground-floor dwelling units in nonelevator buildings shall be adaptable and on an accessible route, unless an accessible route is not required as determined by site impracticality provisions in Section 1150A. For buildings with elevators, see Section 1106A.

Multistory dwellings units shall comply with Section 1102A.3.

1104A.2 Ground floors above grade. Where the first floor containing dwelling units in a building is above grade, all units on that floor shall be served by an accessible route. This floor will be considered a ground floor and all dwelling units are considered covered multifamily dwelling units.

Exception: Carriage units as defined in Section 1107A.3-C and regulated only by the Department of Housing and Community Development as referenced in Section 108.2.1.2.

Multistory dwellings units shall comply with Section 1102A.3.

SECTION 1105A GARAGES, CARPORTS AND PARKING FACILITIES

1105A.1 General. Garages, carports and other parking facilities, which are accessory to covered multifamily dwelling units, shall be accessible as required in Section 1109A.

SECTION 1106A SITE AND BUILDING CHARACTERISTICS

1106A.1 General. Covered multifamily dwellings with elevators shall be designed and constructed to provide at least one accessible entrance on an accessible route, regardless of terrain or unusual characteristics of the site. Covered multifamily dwellings without elevators shall be designed and constructed to provide at least one accessible entrance on an accessible route unless terrain or unusual characteristics of the site prevent an accessible route based on the conditions listed below:

1. **Accessible Entrance.** Regardless of site considerations described in Section 1150A, an accessible entrance on an accessible route is required when there is an elevator connecting the parking area with the dwelling units on a ground floor. (In this case, those dwelling units on the ground floor served by an elevator, and at least one of each type of public- and common-use areas, would be subject to these requirements.)
2. **Elevator Building.** When a building elevator or elevators are provided as a means of access to dwelling units other than dwelling units on a ground floor (see Section 1104A.2), the building is an elevator building. All dwelling units become covered multifamily dwellings in that building. The elevator in that building must provide accessibility to all dwelling units in the building, regardless of the slope of the natural terrain. For multistory dwelling units in building with one or more elevators, see Section 1102A.3.2.

Note: Where a building elevator is provided only as means of creating an accessible route to covered multifamily dwelling units on a ground floor, the building is not considered to be an elevator building, only dwelling units located on the ground floor shall be required to comply with this chapter.

3. **Elevated walkway.** When an elevated walkway is planned between a building entrance and a vehicular or pedestrian arrival point, and the planned walkway has a slope no greater than 10 percent (1 unit vertical in 10 units horizontal), the floor being served by the elevated walkway becomes a ground floor and accessibility to all dwellings on that ground floor is required.

Note: Since the planned walkway meets the 10 percent slope criterion, it is required to provide an accessible route to the entrance, and the slope of the walkway must be reduced to 1 unit vertical in 12 units horizontal (8.33 percent slope) maximum.

1106A.2 Site impracticality. For tests to determine site impracticality due to terrain considerations in nonelevator buildings, see Section 1150A.

SECTION 1107A DEFINITIONS

1107A.1-A

ACCESSIBLE for covered multifamily dwellings is the public- or common-use areas of the building that can be approached, entered and used by persons with disabilities.

ACCESSIBLE ROUTE is a continuous and unobstructed path connecting all accessible elements and spaces in a building or within a site that can be negotiated by a person with a disability using a wheelchair, and that is also safe for and usable by persons with other disabilities. Interior accessible routes may include corridors, hallways, floors, ramps, elevators, and lifts. Exterior accessible routes may include parking access aisles, curb ramps, crosswalks at vehicular ways, walks, ramps, and lifts.

ACCESSIBILITY is the combination of various elements in a building or area which allows access, circulation and the full use of the building and facilities by persons with disabilities.

ADAPTABLE DWELLING UNIT is an accessible dwelling unit within a covered multifamily building as designed with elements and spaces allowing the dwelling unit to be adapted or adjusted to accommodate the user. See Division IV.

ASSISTIVE DEVICE is an aid, tool or instrument used by persons with disabilities to assist in activities of daily living.

AUTOMATIC DOOR is a door equipped with a power-operated mechanism and controls that open and close the door automatically upon receipt of a momentary actuating signal. The switch that begins the automatic cycle may be a photoelectric device, floor mat, or manual switch.

1107A.2-B

BATHROOM is, for the purposes of this chapter, a room which includes a water closet (toilet), lavatory (sink), and a bathtub and/or a shower. It does not include single-fixture facilities or those with only a water closet and lavatory. It does include a compartmented bathroom. A compartmented bathroom is one in which the fixtures are distributed among interconnected rooms. A compartmented bathroom is considered a single unit and is subject to the requirements of this chapter.

BUILDING ENTRANCE ON AN ACCESSIBLE ROUTE is an accessible entrance to a building that is connected by an accessible route to public transportation stops, to parking or passenger loading zones, or to public streets or sidewalks, if available.

1107A.3-C

CARRIAGE UNIT is a dwelling unit with living space on one or more floors immediately above a Group U, Division 1, private garage or garages. The footprint of the garage or garages is used as the footprint for the remaining floor or floors of the units above and the garage level contains no habitable space.

Note: Dwelling units located over a common garage shall not be considered carriage units.

COMMON USE AREAS are private use areas within multifamily residential facilities where the use of these areas is limited exclusively to owners, residents, and their guests. The areas may be defined as rooms or spaces or elements inside or outside of a building.

COVERED MULTIFAMILY DWELLINGS are dwelling units in buildings consisting of 3 or more dwelling units or 4 or more condominium units. Covered multifamily dwellings include dwelling units listed in Section 1102A.1. Dwelling units within a single structure separated by firewalls do not constitute separate buildings.

Note: For buildings or complexes containing publicly funded dwelling units, see Chapter 11B, Section 1111B.5 for provisions of the Division of the State Architect—Access Compliance (DSA-AC).

CROSS SLOPE is the slope that is perpendicular to the direction of travel.

CURB CUT is an interruption of a curb at a pedestrian way, which separates surfaces that are substantially at the same elevation.

CURB RAMP is a sloping pedestrian way, intended for pedestrian traffic, which provides access between a walk or sidewalk and a surface located above or below an adjacent curb face.

1107A.4-D

DETECTABLE WARNING is a standardized surface or feature built into or applied to walking surfaces or other elements to warn visually impaired persons of hazards in the path of travel. Only approved DSA/AC detectable warning products and directional surfaces shall be installed as provided in the CCR, Title 24, Part 1 Articles 2, 3, and 4. Refer to CCR, Title 24, Part 12, Chapter 12-11A and B for building and facilities access specifications for product approval for detectable warning products and directional surfaces.

Note: Detectable warning products and directional surfaces installed after January 1, 2001, shall be evaluated by an independent entity, selected by the Department of General Services, Division of the State Architect - Access Compliance, for all occupancies, including transportation and other outdoor environments, except that when products and surfaces are for use in residential housing, evaluation shall be in consultation with the Department of Housing and Community Development. See Government Code Section 4460.

DWELLING UNIT is a single unit of residence for a family of one or more persons. Examples of dwelling units covered by this chapter include condominiums, an apartment unit within an apartment building, and other types of dwellings in which sleeping accommodations are provided but toileting or cooking facilities are shared by occupants of more than one room or portion of the dwelling. Examples of the latter include dormitory rooms and sleeping accommodations in shelters intended for occupancy as residences for homeless persons.

1107A.5-E

EQUIVALENT FACILITATION is an alternate means of complying with the literal requirements of these standards and specifications that provides access consistent with the purpose of these standards and specifications.

Note:

1. See Section 108.1, Purpose.
2. In determining equivalent facilitation, consideration shall be given to means that provide for the maximum independence of persons with disabilities while presenting the least risk of harm, injury or other hazard to such persons or others.

1107A.6-F

FACILITY (or FACILITIES) is a building, structure, room, site, complex or any portion thereof, that is built, altered, improved or developed to serve a particular purpose.

1107A.7-G

GRAB BAR is a bar for the purpose of being grasped by the hand for support.

GROUND FLOOR is the floor of a building with a building entrance on an accessible route. A building may have one or more ground floors.

1107A.8-H (No definitions)

1107A.9-I

INDEPENDENT ENTITY. See Chapter 2, Section 202.

INTERNATIONAL SYMBOL OF ACCESSIBILITY is that symbol adopted by Rehabilitation International's 11th World Congress for the purpose of indicating that buildings and facilities are accessible to persons with disabilities. See Chapter 11A, Figure 11A-1A.

1107A.10-J (No definitions)

1107A.11-K

KICK PLATE is an abrasion-resistant plate affixed to the bottom portion of a door to prevent a trap condition and protect its surface.

1107A.12-L

LEVEL AREA is a specified surface that does not have a slope in any direction exceeding ¼ inch (6.4 mm) in 1 foot (305 mm) from the horizontal (2.083-percent gradient).

LIFT, PLATFORM (WHEELCHAIR). See "Platform (Wheelchair) Lift."

1107A.13-M

MARKED CROSSING is a crosswalk or other identified marked path intended for pedestrian use in crossing a vehicular way.

MULTISTORY DWELLING UNIT is a dwelling unit with finished living space located on one floor and the floor or floors immediately above or below it.

1107A.14-N

NEWLY CONSTRUCTED is a building that has never before been used or occupied for any purpose.

NOSE, NOSING is that portion of a tread projecting beyond the face of the riser immediately below.

1107A.15-O

OPEN RISER is the airspace between a tread projecting beyond the face of the riser immediately below.

1107A.16-P

PASSAGE DOOR is a door other than an exit door through which persons may traverse.

PEDESTRIAN is an individual who moves within walking areas with or without the use of walking-assistive devices such as crutches, leg braces, wheelchairs, etc.

PEDESTRIAN RAMP is a sloping accessible route intended for pedestrian traffic and is differentiated from a curb ramp.

PEDESTRIAN WAY is a route by which a pedestrian may pass.

PERSONS WITH DISABILITIES, for purposes of this chapter, “persons with disabilities” includes, but is not limited to, any physical or mental disability as defined in Government Code Section 12926.

PLATFORM (WHEELCHAIR) LIFT is a hoisting and lowering mechanism equipped with a car or platform, or support, which serves two landings of a building or structure and is designed to carry a passenger or passengers and/or luggage or other material a vertical distance as may be allowed by Section 1124A.11.

POWDER ROOM is a room containing a water closet (toilet) and lavatory (sink), and which is not defined as a bathroom in Section 1107A.2-B.

PRIMARY ENTRY is the principal entrance through which most people enter the building, as designated by the building official.

PRIMARY ENTRY LEVEL is the floor or level of the building on which the primary entry is located.

PUBLIC ACCOMMODATION. See Chapter 2, Section 202.

PUBLIC USE AREAS means interior or exterior rooms or spaces of a building that are made available to the general public and does not include Common Use Areas as defined in Section 1107A.3-C. Public Use Areas may be provided at a building that is privately or publicly owned.

1107A.17-Q (No definitions)

1107A.18-R

RAMP. See “Pedestrian ramp,” Section 1107A.16-P.

RISER is the vertical distance from the top of a tread to the top of the next higher tread.

1107A.19-S

SIDEWALK. See “Sidewalk,” Chapter 2, Section 202.

SLEEPING ACCOMMODATIONS are rooms in which people may sleep; for example, dormitory and hotel or motel guest rooms or suites.

SLOPE is the relative steepness of the land between two points and is calculated as follows:

The horizontal distance and elevation change between the two points (e.g., an entrance and a passenger loading zone). The difference in elevation is divided by the distance and the resulting fraction is multiplied by 100 to obtain the percentage of slope.

For example: if a principal entrance is 10 feet (3048 mm) from a passenger loading zone, and the principal entrance is raised 1 foot (305 mm) higher than the passenger loading zone, then the slope is $1/10 \times 100 = 10$ percent.

1107A.20-T

TRANSIENT LODGING is a building, facility, or portion thereof, available to the public as an inn, hotel, motel, timeshare, or place where one or more dwelling units or sleep-

ing accommodations are provided for transient guests, excluding inpatient medical care facilities and lodging houses with 5 or less guest rooms. Transient lodging may include but is not limited to, resorts, group homes, and dormitories.

TREAD is the horizontal member of a step.

TREAD DEPTH is the horizontal distance from front to back of tread, including nosing when used.

TREAD RUN is the horizontal distance from the leading edge of a tread to the leading edge of an adjacent tread.

1107A.21-U (No definitions)

1107A.22-V

VEHICULAR OR PEDESTRIAN ARRIVAL POINTS are public or resident parking areas, public transportation stops, passenger loading zones, and public streets or sidewalks.

1107A.23-W

WALK is a surfaced pedestrian way not located contiguous to a street used by the public. (See Chapter 2, Section 202 definition for “Sidewalk.”)

WHEELCHAIR. See “Wheelchair,” Chapter 2, Section 202.

1107A.24-X (No definitions)

1107A.24-Y (No definitions)

Division II—EXTERIOR FACILITIES

Division II Table of Contents

Section 1108A	General Requirements for Accessible Parking and Exterior Routes of Travel
Section 1109A	Parking Facilities
Section 1110A	Exterior Routes of Travel
Section 1111A	Changes in Level on Accessible Routes
Section 1112A	Curb Ramps on Accessible Routes
Section 1113A	Walks and Sidewalks on an Accessible Route
Section 1114A	Exterior Ramps and Landings on Accessible Routes
Section 1115A	Exterior Stairways
Section 1116A	Hazards on Accessible Routes

SECTION 1108A

GENERAL REQUIREMENTS FOR ACCESSIBLE PARKING AND EXTERIOR ROUTES OF TRAVEL

Notes:

- In addition to provisions of this division, exterior routes of travel that provide access to, or egress from, buildings for persons with disabilities shall also comply with Chapter 10.
- Public use areas, public accommodations, and housing which is publicly funded as defined in Chapter 2, Chapter 11A, and Chapter 11B of this code are subject to provisions of the Division of the State Architect (DSA-AC) and are referenced in Section 109.1.1.

SECTION 1109A PARKING FACILITIES

1109A.1 Accessible parking required. Each parking facility provided for covered multifamily dwellings and facilities (e.g., swimming pools, club houses, recreation areas, and laundry rooms) that serve covered multifamily dwellings shall provide accessible parking as required by this section.

1109A.2 Parking facilities. Parking facilities shall include, but not be limited to, the following:

1. Garages.
 - > 2. Private garages.
 3. Carports.
 4. Off-street parking (parking lots/spaces).
- > **1109A.2.1 Private garages.** Private garages accessory to covered multifamily dwelling units shall be accessible as required in Section 1109A. Private garages include individual garages and multiple individual garages grouped together.

Exception: An attached private garage directly serving a single covered multifamily dwelling unit providing at least one of the following options:

1. A door leading directly from the covered dwelling unit which immediately enters the garage. The door shall comply on both sides with Sections 1132A.3 through 1132A.9.
2. An accessible route of travel from the covered dwelling unit to an exterior door entering the garage. See Section 1132A.1 for requirements at both exit doors.
3. An accessible route of travel from the dwelling unit's primary entry door to the vehicular entrance at the garage. See Section 1132A.1 for requirements at the primary entry door.

1109A.3 Required accessible parking spaces. Accessible parking spaces shall be provided at a minimum rate of 2 percent of the covered multifamily dwelling units. At least one space of each type of parking facility shall be made accessible even if the total number exceeds 2 percent. When assigned parking is provided, signage as required by Section 1109A.8.8 shall not be required.

1109A.4 Assigned accessible parking spaces. When assigned parking spaces are provided for a resident or a group of residents, at least 2 percent of the assigned parking spaces serving covered multifamily dwelling units shall be accessible in each type of parking facility. At least one space of each type of parking facility shall be made accessible even if the total number exceeds 2 percent. When assigned parking is provided, signage as required by Section 1109A.8.8 shall not be required.

1109A.5 Unassigned and visitor parking spaces. When parking is provided for covered multifamily dwellings and is not assigned to a resident or a group of residents at least 5 percent of the parking spaces shall be accessible and provide access to grade-level entrances of covered multifamily dwellings and facilities (e.g., swimming pools, club houses, recreation areas, and laundry rooms) that serve covered multifamily dwellings. Accessible parking spaces shall be provided with signage as required by Section 1109A.8.8. Such signage shall not be blocked from view by a vehicle parked in the space.

1109A.6 Requests for accessible parking spaces. When assigned parking is provided, designated accessible parking for the dwelling unit shall be provided on request of residents with disabilities on the same terms and with the full range of choices (e.g., off-street parking, carport or garage) that are available for other residents.

1109A.7 Location of accessible parking spaces. The location of accessible parking spaces shall comply with the following:

1. Accessible parking spaces shall be located on the shortest possible accessible route to an accessible building, or covered multifamily dwelling unit entrance. All van accessible spaces may be grouped on one level of a parking facility.
2. When parking facilities are located adjacent to a building with multiple accessible entrances, accessible parking spaces shall be dispersed and located near the accessible building entrances.
3. When practical, the accessible route shall not cross lanes for vehicular traffic. When crossing vehicle traffic lanes is necessary, the accessible route shall be designated and marked as a crosswalk.
4. Parking facilities that do not serve a particular building shall have accessible parking spaces located on the shortest possible accessible route to an accessible pedestrian entrance of the parking facility.
5. Accessible parking spaces shall be located so that persons with disabilities are not compelled to wheel or walk behind parked cars other than their own.

Exception: When the enforcement agency determines that compliance with this section or providing equivalent facilitation would create an unreasonable hardship, parking spaces may be provided which would require a person with physical disabilities to wheel or walk behind other than accessible parking spaces.

1109A.8 Design and construction. Accessible parking required by this section shall be designed and constructed in accordance with Section 1109A.

1109A.8.1 Vertical clearances. Where required to be accessible, all entrances into, and vertical clearances within parking facilities shall have a minimum vertical clearance of 8 feet 2 inches (2489 mm) from the floor to the lowest projection from the ceiling.

1109A.8.2 Arrangement of parking spaces. Parking spaces shall be arranged to comply with the following:

1. In each parking area, a bumper or curb shall be provided and located to prevent encroachment of cars over the required width of walkways.
2. Ramps, including curb ramps, shall not encroach into any accessible parking space or the adjacent loading and unloading access aisle.

1109A.8.3 Slope of accessible parking spaces and access aisles. Surface slopes of accessible parking spaces and access aisles shall be the minimum possible and shall not exceed ¼ inch (6.35 mm) per foot (2.083-percent gradient) in any direction.

1109A.8.4 Accessible parking space size. Accessible parking spaces shall comply with Sections 1109A.8.5 and 1109A.8.6.

1109A.8.5 Accessible single parking space. Where accessible single spaces are provided, they shall be constructed in accordance with the following:

1. Single spaces shall be 14 feet (4267 mm) wide and lined to provide a 9 foot (2743 mm) wide parking area and a 5 foot (1524 mm) wide loading and unloading access aisle on the passenger side of the vehicle (see Figure 11A-2B) with the vehicle parked in the forward position.
2. When more than one space is provided, two 9 foot (2743 mm) wide parking spaces may be lined on each side of a 5 foot (1524 mm) wide loading and unloading access aisle (see Figure 11A-2A, and 11A-2C).
3. The minimum length of each parking space shall be 18 feet (5486 mm).
4. The words "NO PARKING" shall be painted on the ground within each 5 foot (1524 mm) wide loading and unloading access aisle. This notice shall be painted in white letters no less than 12 inches (305 mm) high and located so that it is visible to traffic enforcement officials (see Figures 11A-2A, 11A-2B, and 11A-2C).

1109A.8.6 Van accessible parking space. One in every eight accessible spaces, but not less than one, shall be van accessible and shall be constructed in accordance with the following:

1. Each space shall be served by a loading and unloading access aisle at least 8 feet (2438 mm) wide, placed on the passenger side with the vehicle parked in the forward position.
2. The minimum length of each space shall be 18 feet (5486 mm).
3. Each space shall be designated "van accessible" as required by Section 1109A.8.8.
4. All van accessible spaces may be grouped on one level of a parking facility.
5. The words "NO PARKING" shall be painted on the ground within each 8 foot (2438 mm) wide loading and unloading access aisle. This notice shall be painted in white letters no less than 12 inches (305 mm) high and located so that it is visible to traffic enforcement officials.

Note: See Figures 11A-2A, 11A-2B, and 11A-2C.

1109A.8.7 Adjacent parking. Parking spaces adjacent to accessible parking spaces shall not be considered as loading and unloading access aisles.

1109A.8.8 Parking signage. Each accessible parking space reserved for persons with disabilities shall be identified by a reflective sign permanently posted immediately adjacent to and visible from each stall or space consisting of the "International Symbol of Accessibility" in white on a dark blue background. The sign shall not be smaller than 70 square inches (4516 mm²) in area and, when in a path of travel,

shall be posted at a minimum height of 80 inches (2032 mm) from the bottom of the sign to the parking space finished grade. Signs may also be centered on the wall at the interior end of the parking space at a minimum height of 36 inches (914 mm) from the parking space finished grade, ground or sidewalk. Van accessible spaces shall comply with Section 1109A.8.6 and shall have an additional sign or additional language stating "Van Accessible" below the symbol of accessibility.

Note: When assigned resident parking is provided, signage is not required except for unassigned or visitor parking spaces.

An additional sign shall also be posted in a conspicuous place at each entrance to off-street parking facilities or immediately adjacent to and visible from each accessible stall or space. The sign shall not be less than 17 inches (432 mm) by 22 inches (559 mm) in size with lettering not less than 1 inch (25.4 mm) in height, and shall clearly and conspicuously state the following:

"Unauthorized vehicles parked in designated accessible spaces not displaying distinguishing placards or license plates issued for persons with disabilities may be towed away at owner's expense. Towed vehicles may be reclaimed at _____ or by telephoning _____."

Blank spaces are to be filled in with appropriate information as a permanent part of the sign.

In addition to the above requirements, the surface of each accessible parking space shall have a surface identification duplicating either of the following schemes:

1. By outlining or painting the stall or space in blue and outlining on the ground in the stall or space in white or suitable contrasting color the "International Symbol of Accessibility"; or,
2. By outlining the "International Symbol of Accessibility" in white on blue background. The "International Symbol of Accessibility" shall be located so that it is visible to a traffic enforcement officer when a vehicle is properly parked in the space and shall be 36 inches high by 36 inches wide (914 mm by 914 mm).

Note: See Figures 11A-2A, 11A-2B, and 11A-2C.

SECTION 1110A EXTERIOR ROUTES OF TRAVEL

1110A.1 Exterior accessible route. When a building or portion of a building is required to be accessible or adaptable, an accessible route shall be provided to all portions of the building, accessible building entrances and between the building and the public way. The accessible route shall be the most practical direct route and to the maximum extent feasible, coincide with the route for the general public and building residents. Exterior accessible routes shall be provided as follows:

1. Where more than one route of travel is provided, all routes shall be accessible.

2. At least one accessible route within the boundary of the site shall be provided from public transportation stops, accessible parking and accessible passenger loading and unloading zones, and public streets or sidewalks to the accessible building entrance they serve.
3. At least one accessible route shall connect accessible buildings, facilities, elements and spaces that are on the same site. Accessible routes shall be provided between accessible buildings and accessible site facilities when more than one building or facility is located on a site.
4. At least one accessible route shall connect accessible building or facility entrances with all accessible spaces, elements, and covered multifamily dwelling units.
5. An accessible route shall connect at least one accessible entrance of each covered multifamily dwelling unit with exterior spaces and facilities that serve the dwelling unit.
6. Where elevators are provided for vertical access, all elevators shall be accessible. See Section 1124A.

Note: If the slope of the finished grade between covered multifamily dwellings and a public use or common use facility (including parking) exceeds 1 unit vertical in 12 units horizontal (8.33-percent slope), or where other physical barriers (natural or artificial) or legal restrictions, all of which are outside the control of the owner, prevent the installation of an accessible route, an acceptable alternative is to provide access by a vehicular route, provided:

1. There is accessible parking on an accessible route for at least 2 percent of the covered multifamily dwelling units, and
2. Necessary site provisions such as parking spaces and curb ramps are provided at the public use or common use facility.

1110A.2 Signs. At every primary public entrance and at every major junction where the accessible route diverges from the circulation path along or leading to an accessible route, entrance or facility, there shall be a sign displaying the “International Symbol of Accessibility.” Signs shall indicate the direction to accessible building entrances and facilities and shall comply with the requirements found in Section 1143A.2.

1110A.3 Flooring. If carpet or carpet tile is used in a common-use area or public-use area on a ground or floor surface, it shall have firm backing or no backing. The maximum pile height shall be 1/2 inch (12.7 mm). Exposed edges of carpet shall be fastened to floor surfaces and have trim along the entire length of the exposed edge. Carpet edge trim shall comply with Section 1111A requirements for changes in level.

1110A.3.1 Recessed doormats. Recessed doormats shall be adequately anchored to prevent interference with wheelchair traffic.

SECTION 1111A CHANGES IN LEVEL ON ACCESSIBLE ROUTES

1111A.1 Changes in level not exceeding 1/2 inch. Abrupt changes in level along any accessible route shall not exceed 1/2

inch (12.7 mm). When changes in level do occur, they shall be beveled with a slope no greater than 1 unit vertical in 2 units horizontal (50-percent slope). Changes in level not exceeding 1/4 inch (6.35 mm) may be vertical.

1111A.2 Changes greater than 1/2 inch. Changes in level greater than 1/2 inch (12.7 mm) shall be made by means of a sloped surface not greater than 1 unit vertical in 20 units horizontal (5-percent slope), or a curb ramp, ramp, elevator or platform (wheelchair) lift. Stairs shall not be part of an accessible route. When stairs are located along or adjacent to an accessible route they shall comply with Section 1115A for exterior stairways.

SECTION 1112A CURB RAMPS ON ACCESSIBLE ROUTES

1112A.1 General. Curb ramps within the boundary of the site shall be constructed at each corner of street intersections and where a pedestrian way crosses a curb. The preferred and recommended location for curb ramps is in the center of the crosswalk of each street corner. Where it is necessary to locate a curb ramp in the center of the curb return, the street surfaces shall be marked to identify pedestrian crosswalks, and the lower end of the curb ramp shall terminate within such crosswalk areas. Curb ramps do not require handrails.

1112A.2 Obstructions. Curb ramps shall be located or protected to prevent obstruction by parked cars. Built-up curb ramps shall be located so that they do not project into vehicular traffic lanes, parking spaces, or the adjacent loading and unloading access aisle.

1112A.3 Width of curb ramps. Curb ramps shall be a minimum of 48 inches (1219 mm) in width.

1112A.4 Diagonal curb ramps. If diagonal (or corner-type) curb ramps have returned curbs or other well-defined edges, such edges shall be parallel to the direction of pedestrian flow. The bottom of diagonal curb ramps shall have a 48 inch (1219 mm) minimum clear space as shown in Figures 11A-3A through 11A-3M. If diagonal curb ramps are provided at marked crossings, the 48 inch (1219 mm) clear space shall be within the markings (see Figures 11A-3A through 11A-3M). If diagonal curb ramps have flared sides, they shall also have at least a 24-inch-long (610 mm) segment of straight curb located on each side of the curb ramp and within the marked crossing. See Figures 11A-3A through 11A-3M.

1112A.5 Slope of curb ramps. The slope of curb ramps shall not exceed 1 unit vertical to 12 units horizontal (8.33-percent slope) and shall lie, generally, in a single sloped plane. Transitions from ramps to walks, gutters, or streets shall be flush and free of abrupt changes. Maximum slopes of adjoining gutters, road surface immediately adjacent to the curb ramp, or accessible route shall not exceed 1 unit vertical to 20 units horizontal (5-percent slope) within 4 feet (1219 mm) of the top and bottom of the curb ramp.

If a curb ramp is located where pedestrians must walk across the ramp, then it shall have flared sides; the maximum slope of the flare shall be 1 unit vertical in 10 units horizontal (10-percent slope). Curb ramps with returned curbs may be used

where pedestrians would not normally walk across the ramp. See Figures 11A-3A through 11A-3M.

1112A.6 Level landing. A level landing 48 inches (1219 mm) deep shall be provided at the upper end of each curb ramp over its full width to permit safe egress from the ramp surface, or the slope of the fanned or flared sides of the curb ramp, shall not exceed 1 unit vertical to 12 units horizontal (8.33-percent slope).

1112A.7 Finish. The surface of each curb ramp and its flared sides shall be stable, firm and slip-resistant and shall be of contrasting finish from that of the adjacent sidewalk.

1112A.8 Border. All curb ramps shall have a grooved border 12 inches (305 mm) wide at the level surface of the sidewalk along the top and each side approximately $\frac{3}{4}$ inch (19 mm) on center. All curb ramps constructed between the face of the curb and the street shall have a grooved border at the level surface of the sidewalk. See Figures 11A-3A through 11A-3K.

1112A.9 Detectable warnings. See Chapter 11B, Section 1127B.5, Item 7.

SECTION 1113A WALKS AND SIDEWALKS ON AN ACCESSIBLE ROUTE

1113A.1 Width and continuous surface. Walks and sidewalks subject to this chapter shall have a continuous common surface, not interrupted by steps or by abrupt changes in level exceeding $\frac{1}{2}$ inch (12.7 mm). (See Section 1111A.3).

1113A.1.1 Width. Walks and sidewalks shall be a minimum of 48 inches (1219 mm) in width, except that walks serving an individual dwelling unit in covered multifamily buildings may be reduced to 36 inches (914 mm) in clear width except at doors.

1113A.1.2 Surfaces. Surfaces shall be slip-resistant as follows:

1. Surfaces with a slope of less than 6 percent gradient shall be at least as slip-resistant as that described as a medium salted finish.
2. Surfaces with a slope of 6 percent or greater gradient shall be slip-resistant.

1113A.1.3 Surface cross slopes. Surface cross slopes shall not exceed $\frac{1}{4}$ inch (6.35 mm) per foot (2.083-percent slope) except when the enforcing agency finds that due to local conditions it creates an unreasonable hardship, the cross slope may be increased to a maximum of $\frac{1}{2}$ inch (12.7 mm) per foot (4.2-percent slope) for distances not to exceed 20 feet (6096 mm).

1113A.2 Walks with continuous gradients. All walks on an accessible route with continuous gradients shall have level areas at least 60 inches (1524 mm) in length at intervals of at least every 400 feet (122 m).

1113A.3 Five percent gradient. When the slope in the direction of travel of any walk on an accessible route exceeds 1 unit vertical in 20 units horizontal (5-percent slope), it shall comply with the ramp provisions of Section 1114A.

1113A.4 Level areas. Walks on an accessible route shall be provided with a level area not less than 60 inches by 60 inches (1524 mm by 1524 mm) at a door or gate that swings toward the walk, and not less than 48 inches wide by 44 inches (1219 mm by 1118 mm) deep at a door or gate that swings away from the walk. See Section 1126A.3.2 for strike edge maneuvering space at doors or gates.

1113A.5 Smooth surface. The bottom 10 inches (254 mm) of all doors and/or gates except automatic and sliding doors or gates shall have a smooth, uninterrupted surface to allow the door or gate to be opened by a wheelchair footrest without creating a trap or hazardous condition. Where narrow frame doors are used, a 10 inch (254 mm) high smooth panel shall be installed on the push side of the door, which will allow the door to be opened by a wheelchair footrest without creating a trap or hazardous condition.

1113A.6 Gratings. Walks, sidewalks and pedestrian ways on an accessible route shall be free of gratings whenever possible. Gratings located in the surface of any of these areas, grid openings in gratings shall be limited to $\frac{1}{2}$ inch (12.7 mm) in the direction of traffic flow.

Exceptions:

1. Where the enforcement agency determines that compliance with this section would create an unreasonable hardship, an exception may be granted when equivalent facilities are provided.
2. This section shall not apply in those conditions where, due to legal or physical constraints, all or portions of the site of the project will not allow compliance with these building standards or equivalent facilitation on all or portions of one site without creating an unreasonable hardship.

SECTION 1114A EXTERIOR RAMPS AND LANDINGS ON ACCESSIBLE ROUTES

1114A.1 Width. The width of ramps shall be consistent with the requirements for exits in Chapter 10 of this code, but in no case shall the ramp width be less than the following:

1. Ramps serving accessible entrances to covered multifamily buildings where the ramp is the only exit discharge path and serves an occupant load of 300 or more shall have a minimum clear width of 60 inches (1524 mm).
2. Ramps serving accessible entrances in Group R occupancies with an occupant load of 10 or less may be 36 inches (914 mm) in clear width.
3. All other ramps shall have a minimum clear width of 48 inches (1219 mm).
4. Handrails, curbs, wheel guides and/or appurtenances shall not project into the required clear width of a ramp.

Note: See Section 1114A.6.2.4 for handrail projections.

1114A.2 Slope. The maximum slope of ramps on an accessible route shall be no greater than 1 unit vertical in 12 units hori-

zontal (8.33-percent slope). Transitions from ramps to walks, gutters or streets shall be flush and free of abrupt changes.

Exception: Ramps serving decks, patios or balconies as specified in Section 1132A.4.

1114A.2.1 Cross slope. The cross slope of ramp surfaces shall be no greater than 1/4 inch (6.35 mm) per foot (2.083-percent slope).

1114A.3 Outdoor ramps. Outdoor ramps, ramp landings and their approaches shall be designed so that water will not accumulate on the walking surface.

1114A.4 Landings. Ramp landings shall be level and comply with this section.

1114A.4.1 Location of landings. Landings shall be provided at the top and bottom of each ramp. Intermediate landings shall be provided at intervals not exceeding 30 inches (762 mm) of vertical rise and at each change of direction. Landings are not considered in determining the maximum horizontal distance of each ramp.

Note: Examples of ramp dimensions are:

SLOPE (GRADING %)	MAXIMUM RISE (INCHES)	MAXIMUM HORIZONTAL PROJECTION (feet)
	(x 25.4 for mm)	(x 304.8 for mm)
1:12 (8.33%)	30	30
1:15 (6.67%)	30	37.5
1:16 (6.25%)	30	40
1:20 (5.00%)	30	50

1114A.4.2 Size of top landings. Top landings shall not be less than 60 inches (1524 mm) wide. Top landings shall have a minimum length of not less than 60 inches (1524 mm) in the direction of the ramp run. See Section 1126A.3 for maneuvering clearances at doors.

1114A.4.3 Landing width. The minimum width of bottom and intermediate landings shall not be less than the width of the ramp.

1114A.4.4 Encroachment of doors. Doors in any position shall not reduce the minimum dimension of the landing to less than 42 inches (1067 mm) and shall not reduce the required width by more than 3 inches (76.2 mm) when fully open. (See Figure 11A-6D).

1114A.4.5 Strike edge extension. The width of the landing shall comply with Section 1126A.3 for strike edge extension and maneuvering space at doors.

1114A.4.6 Change of direction. Intermediate and bottom landings at a change of direction in excess of 30 degrees shall have a length in the direction of ramp run of not less than 72 inches (1829 mm). (See Figures 11A-6C and 11A-6D).

1114A.4.7 Other intermediate landings. Other intermediate landings shall have a dimension in the direction of ramp run of not less than 60 inches (1524 mm). (See Figure 11A-6C).

1114A.5 Ramp height. Ramps more than 30 inches (762 mm) above the adjacent floor or ground and open on one or both sides shall be provided with guardrails as required by Section

509. Guardrails shall be continuous from the top of the ramp to the bottom of the ramp.

1114A.6 Ramp handrails.

1114A.6.1 Where required. Handrails shall be provided at each side of ramps when the slope exceeds 1 unit vertical in 20 units horizontal (5% slope). Handrails on all ramps shall be continuous.

Exceptions:

1. Curb ramps.
2. Ramps that serve an individual dwelling unit may have one handrail, except that ramps open on one or both sides shall have handrails provided on the open side or sides.
3. Ramps at exterior door landings with less than 6 inches (152 mm) rise or less than 72 inches (1829 mm) in length.

1114A.6.2 Handrail configuration.

1114A.6.2.1 Handrail heights. The top of handrails shall be 34 to 38 inches (864 to 965 mm) above the ramp surface.

1114A.6.2.2 Handrail ends. Handrail ends shall be returned.

1114A.6.2.3 Handrail extension. Handrails shall extend a minimum of 12 inches (305 mm) beyond the top and bottom of the ramp. Where the extension creates a hazard, the termination of the extension shall be rounded or returned smoothly to floor, wall or post. (See Figure 11A-5A).

1114A.6.2.4 Handrail projections. Handrails projecting from a wall shall have a space of 1 1/2 inches (38.1 mm) between the wall and the handrail. Handrails shall not reduce the required minimum clear width of ramps.

Handrails may be located in a recess if the recess is a maximum of 3 inches (76.2 mm) deep and extends at least 18 inches (457 mm) above the top of the rail. Any wall or other surface adjacent to the handrail shall be free of sharp or abrasive elements. (See Figure 11A-6B).

1114A.6.2.5 Handrail grips. The handgrip portion of handrails shall not be less than 1/4 inches (31.75 mm) nor more than 2 inches (50.8 mm) in cross-sectional dimension or the shape shall provide an equivalent gripping surface. The handgrip portion of handrails shall have a smooth surface with no sharp corners. Edges shall have a minimum radius of 1/8 inch (3.17 mm). Handrails shall not rotate within their fittings. (See Figure 11A-6B).

Note: For public use areas, public accommodations, and housing which is publicly funded, see Chapter 11B, Division III, Section 1133B.5.5 for provisions of the Division of the State Architect—Access Compliance (DSA-AC).

1114A.7 Curbs and wheel guides. Ramps exceeding 10 feet (3048 mm) in length and ramp landings having a vertical drop exceeding 4 inches (101.6 mm), shall be provided with one of the following:

1. Guide curbs a minimum of 2 inches (50.8 mm) in height at each side; or
2. Wheel guide rails at each side, centered 2 to 4 inches (50.8 to 101.6 mm) above the surface of the ramp or ramp landing.

Exception: Ramps or ramp landings bounded by a wall or fence.

Note: See Figure 11A-5A.

SECTION 1115A EXTERIOR STAIRWAYS

1115A.1 General. Exterior stairways serving buildings on a site containing covered multifamily dwelling units shall comply with this section.

1115A.2 Open risers. Open risers are not permitted on exterior stairways.

Exceptions:

1. An opening of not more than $\frac{1}{2}$ inch (12.7 mm) may be permitted between the base of the riser and the tread.
2. Risers constructed of grating containing openings of not more than $\frac{1}{2}$ inch (12.7 mm) may be permitted.

1115A.3 Treads. All tread surfaces shall be slip resistant. Treads shall have smooth, rounded or chamfered exposed edges, and no abrupt edges at the nosing (lower front edge).

1115A.4 Nosing. Nosing shall not project more than $1\frac{1}{4}$ inches (31.8 mm) past the face of the riser below. Risers shall be sloped or the underside of the nosing shall have an angle not more than 30 degrees (0.52 rad) from the vertical. (See Figure 11A-6A).

1115A.5 Striping for the visually impaired. Exterior stairs serving buildings on a site containing multifamily dwelling units shall have the upper approach and all treads marked by a stripe providing clear visual contrast.

The stripe shall be a minimum of 2 inches (50.8 mm) wide to a maximum of 4 inches (101.6 mm) wide placed parallel to, and not more than 1 inch (25.4 mm) from, the nose of the step or upper approach. The stripe shall extend the full width of the step or upper approach and shall be of material that is at least as slip resistant as the other treads of the stair. A painted stripe shall be acceptable.

1115A.6 Exterior stairway handrails.

1115A.6.1 Where required. Stairways shall have handrails on each side. Intermediate handrails shall be located equidistant from the sides of the stairway and comply with Section 1012.8.

Exception: Stairways serving an individual dwelling unit may have one handrail, except that stairways open on one or both sides shall have handrails on the open side or sides.

1115A.6.2 Handrail configuration.

1115A.6.2.1 Handrail heights. The top of handrails shall be 34 to 38 inches (864 to 965 mm) above the nosing of the treads.

1115A.6.2.2 Handrail ends. Ends shall be returned or shall terminate in newel posts or safety terminals.

1115A.6.2.3 Handrail extension. Handrails shall extend a minimum of 12 inches (305 mm) beyond the top nosing and 12 inches (305 mm), plus the tread width, beyond the bottom nosing.

Where the extension creates a hazard, the termination of the extension shall be rounded or returned smoothly to floor, wall or post. Where the stairs are continuous from landing to landing, the inner rail shall be continuous and need not extend out into the landing. (See Figures 11A-6A and 11A-6E).

1115A.6.2.4 Handrail projections. Handrails projecting from a wall shall have a space of $1\frac{1}{2}$ inches (38.1 mm) between the wall and the handrail.

Handrails may be located in a recess if the recess is a maximum of 3 inches (76.2 mm) deep and extends at least 18 inches (457 mm) above the top of the rail. Any wall or other surface adjacent to the handrail shall be free of sharp or abrasive elements. (See Figure 11A-6B).

1115A.6.2.5 Handrail grips. The handgrip portion of handrails shall not be less than $1\frac{1}{4}$ inches (31.75 mm) nor more than 2 inches (50.8 mm) in cross-sectional dimension or the shape shall provide an equivalent gripping surface. The handgrip portion of handrails shall have a smooth surface with no sharp corners. Edges shall have a minimum radius of $\frac{1}{8}$ inch (3.17 mm). Handrails shall not rotate within their fittings. (See Figure 11A-6B).

Note: For public use areas, public accommodations, and housing which is publicly funded, see Chapter 11B, Division III, Section 1133B.4.2.6 for provisions of the Division of the State Architect—Access Compliance (DSA-AC).

SECTION 1116A HAZARDS ON ACCESSIBLE ROUTES

1116A.1 Warning curbs. Abrupt changes in level exceeding 4 inches (101.6 mm) in vertical dimension, such as changes in level at planters or fountains located in or adjacent to walks, sidewalks or other pedestrian ways shall be identified by curbs or other approved barriers projecting at least 6 inches (152.4 mm) in height above the walk or sidewalk surface to warn the blind of a potential drop-off.

Exceptions:

1. Between a walk or sidewalk and an adjacent street or driveway.
2. When a guardrail or handrail is provided with a wheel guide centered 2 to 4 inches (50.8 to 101.6 mm) above the surface of the walk or sidewalk.

1116A.2 Headroom clearance. Walks, pedestrian ways and other circulation spaces which are part of the required egress system shall have a minimum clear headroom of 84 inches (2134 mm). Other walks, pedestrian ways and circulation spaces shall have a minimum clear headroom of 80 inches (2032 mm). If the vertical clearance of an area adjoining an accessible route is reduced to less than 80 inches (2032 mm) nominal dimension, a guardrail or other barrier having its

leading edge at or below 27 inches (686 mm) above the finished floor shall be provided. (See Figure 11A-1B.)

Exception: Doorways and archways less than 24 inches (610 mm) in depth may have a minimum clear headroom of 80 inches (2032 mm) nominal. (See Section 1126A.)

1116A.3 Overhanging obstructions. Any obstruction that overhangs a pedestrian way shall be a minimum of 80 inches (2032 mm) above the walking surface as measured from the bottom of the obstruction. Where a guy support is used parallel to a path of travel, including, but not limited to, sidewalks, a guy brace, sidewalk guy or similar device shall be used to prevent an overhanging obstruction (see Section 1116A.2 for required headroom clearance).

1116A.4 Free-standing signs. Wherever signs mounted on posts or pylons protrude from the post or pylons and the bottom edge of the sign is 80 inches (2032 mm) above the finished floor or ground level, the edges of such signs shall be rounded or eased and the corners shall have a minimum radius of 0.125 inches (see Section 1116A.2 for required headroom clearance).

Division III—BUILDING FEATURES

Division III Table of Contents

Section 1117A	General Requirements for Accessible Entrances, Exits, Interior Routes of Travel and Facility Accessibility
Section 1118A	Egress and Areas of Refuge
Section 1119A	Interior Routes of Travel
Section 1120A	Interior Accessible Routes
Section 1121A	Changes in Level on Accessible Routes
Section 1122A	Interior Ramps and Landings on Accessible Routes
> Section 1123A	Interior Stairways
Section 1124A	Elevators and Platform (Wheelchair) Lifts
Section 1125A	Hazards on Accessible Routes
Section 1126A	Doors
Section 1127A	Common Use Facilities

SECTION 1117A GENERAL REQUIREMENTS FOR ACCESSIBLE ENTRANCES, EXITS, INTERIOR ROUTES OF TRAVEL AND FACILITY ACCESSIBILITY

Note: In addition to provisions of this division, interior routes of travel that provide access to, or egress from, buildings for persons with disabilities shall also comply with Chapter 10.

1117A.1 General. When buildings are required to be accessible, building facilities shall be accessible as provided in this division. Where specific floors of a building are required to be accessible, the requirements of this division shall apply only to the facilities located on accessible floors.

1117A.2 Primary entrances and exterior exit doors. All primary entrances and exterior ground floor exit doors to build-

ings and facilities on accessible routes shall be accessible to persons with disabilities.

1117A.3 Separate dwelling unit entrances. When a ground-floor dwelling unit of a building has a separate entrance, each such ground-floor dwelling unit shall be served by an accessible route, except where the terrain or unusual characteristics of the site prohibit an accessible route (see Section 1150A for site impracticality tests).

1117A.4 Multiple entrances. Only one entrance to covered multifamily buildings is required to be accessible to any one ground floor of a building, except in cases where an individual dwelling unit has a separate exterior entrance. Where the building contains clusters of dwelling units with each cluster sharing a different exterior entrance, more than one entrance may be required to be accessible, as determined by analysis of the site. In every case, the accessible entrance shall be on an accessible route to the covered dwelling units it serves.

SECTION 1118A EGRESS AND AREAS OF REFUGE

1118A.1 General. Including but not limited to the requirements contained in this chapter for accessible routes, signage and emergency warning systems in buildings or portions of buildings required to be accessible shall be provided with accessible means of egress as required by Chapter 10. (See Section 1007.)

SECTION 1119A INTERIOR ROUTES OF TRAVEL

1119A.1 General. When a building or portion of a building is required to be accessible or adaptable, an accessible route shall be provided to all portions of the building, accessible building entrances and to covered multifamily dwelling units. The accessible route shall, to the maximum extent feasible, coincide with the route for the general public and other building residents. Accessible routes shall not pass through kitchens, storage rooms, restrooms, closets or other spaces used for similar purposes except within an individual dwelling unit. Accessible routes shall be provided as follows:

1. Where more than one route of travel is provided, all routes shall be accessible.
2. At least one accessible route shall connect accessible building or facility entrances with all accessible spaces, elements and covered multifamily dwelling units.
3. An accessible route shall connect at least one accessible primary entrance of each covered multifamily dwelling unit with interior and exterior spaces and facilities that serve the unit.
4. Where elevators are provided for vertical access, all elevators shall be accessible.

1119A.2 Flooring. If carpet or carpet tile is used in a common use area or public use area on a ground or floor surface, it shall have firm backing or no backing. The maximum pile height shall be ½ inch (12.7 mm). Exposed edges of carpet shall be fastened to floor surfaces and have trim along the entire length of the exposed edge. Carpet edge trim shall comply with Section 1111A requirements for changes in level.

1119A.2.1 Recessed doormats. Recessed doormats shall be adequately anchored to prevent interference with wheelchair traffic.

**SECTION 1120A
INTERIOR ACCESSIBLE ROUTES**

Note: For the purpose of this section, interior accessible routes shall include but not be limited to corridors, hallways, exit balconies and covered or enclosed walkways.

1120A.1 Widths. Interior accessible routes serving an occupant load of 10 or more shall not be less than 44 inches (1118 mm) in width. Interior accessible routes serving an occupant load of less than 10 shall not be less than 36 inches (914 mm) in width.

If a person in a wheelchair must make a turn around a corner or an obstruction, the minimum clear width of the accessible route shall be as shown in Figure 11A-1C.

1120A.2 Interior accessible routes over 200 feet (60960 mm). Interior accessible routes that exceed 200 feet (60960 mm) in length shall:

1. Have a minimum clear width of 60 inches (1524 mm); or
2. Have at a central location a 60-inch by 60-inch (1524 mm by 1524 mm) minimum wheelchair turning space or passing alcove; or
3. Have at a central location an intervening cross or tee that is a minimum of 44 inches (1118 mm) in width.

Note: See Figure 11A-1L.

1120A.3 Changes in elevation. Interior accessible routes which have changes in elevation shall be transitioned and comply with Section 1121A or 1122A.

Exception: Doors and thresholds as provided in Section 1126A.

**SECTION 1121A
CHANGES IN LEVEL ON ACCESSIBLE ROUTES**

1121A.1 Changes in level not exceeding 1/2 inch. Abrupt changes in level along any accessible route shall not exceed 1/2 inch (12.7 mm). When changes in level do occur, they shall be beveled with a slope no greater than 1 unit vertical in 2 units horizontal (50-percent slope). Changes in level not exceeding 1/4 inch (6.35 mm) may be vertical.

1121A.2 Changes greater than one-half inch. Changes in level greater than 1/2 inch (12.7 mm) shall be made by means of a sloped surface not greater than 1 unit vertical in 20 units horizontal (5-percent slope), or a curb ramp, ramp, elevator or platform (wheelchair) lift. When stairs are located along or adjacent to an accessible route they shall comply with Section 1123A for interior stairways.

**SECTION 1122A
INTERIOR RAMPS AND LANDINGS ON
ACCESSIBLE ROUTES**

1122A.1 Width. The width of ramps shall be consistent with the requirements for exits in Chapter 10 of this code, but in no case shall the ramp width be less than the following:

1. Ramps serving accessible entrances to covered multi-family buildings where the ramp is the only exit discharge path and serves an occupant load of 300 or more shall have a minimum clear width of 60 inches (1524 mm).
2. Ramps serving accessible entrances in Group R occupancies with an occupant load of 10 or less may be 36 inches (914 mm) in clear width.
3. All other ramps shall have a minimum clear width of 48 inches (1219 mm).
4. Handrails, curbs, wheel guides and/or appurtenances shall not project into the required clear width of a ramp.

Note: See Section 1122A.5.2.4 for handrail projections.

1122A.2 Slope. The maximum slope of ramps on an accessible route shall be no greater than 1 unit vertical in 12 units horizontal (8.33-percent slope).

1122A.2.1 Cross slope. The cross slope of ramp surfaces shall not exceed 1/4 inch (6.35 mm) per foot (2.083-percent slope).

1122A.3 Landings. Ramp landings shall be level and comply with this section.

1122A.3.1 Location of landings. Landings shall be provided at the top and bottom of each ramp. Intermediate landings shall be provided at intervals not exceeding 30 inches (762 mm) of vertical rise and at each change of direction. Landings are not considered in determining the maximum horizontal distance of each ramp.

Note: Examples of ramp dimensions are:

SLOPE (GRADING %)	MAXIMUM RISE (INCHES)	MAXIMUM HORIZONTAL PROJECTION (feet)
	(x 25.4 for mm)	(x 304.8 for mm)
1:12 (8.33%)	30	30
1:15 (6.67%)	30	37.5
1:16 (6.25%)	30	40
1:20 (5.00%)	30	50

1122A.3.2 Size of top landings. Top landings shall not be less than 60 inches (1524 mm) wide. Top landings shall have a minimum length of not less than 60 inches (1524 mm) in the direction of the ramp run. See Section 1126A.3 for maneuvering clearances at doors. (See Figure 11A-6C).

1122A.3.3 Landing width. The minimum width of bottom and intermediate landings shall not be less than the width of the ramp.

1122A.3.4 Encroachment of doors. Doors in any position shall not reduce the minimum dimension of the landing to less than 42 inches (1067 mm) and shall not reduce the

required width by more than 3 inches (76.2 mm) when fully open. (See Figure 11A-6d).

1122A.3.5 Strike edge extension. The width of the landing shall comply with Section 1126A.3 for maneuvering clearances at doors.

1122A.3.6 Change of direction. Intermediate and bottom landings at a change of direction in excess of 30 degrees shall have a length in the direction of ramp run of not less than 72 inches (1829 mm). (See Figures 11A-6C and 11A-6D).

1122A.3.7 Other intermediate landings. Other intermediate landings shall have a dimension in the direction of ramp run of not less than 60 inches (1524 mm). (See Figure 11A-6C).

1122A.4 Ramp height. Ramps more than 30 inches (762 mm) above the adjacent floor or ground and open on one or both sides shall be provided with guardrails as required by Section 509. Guardrails shall be continuous from the top of the ramp to the bottom of the ramp.

1122A.5 Ramp handrails.

1122A.5.1 Where required. Handrails shall be provided at each side of ramps when the slope exceeds 1 unit vertical in 20 units horizontal (5-percent slope). Handrails on all ramps shall be continuous.

Exceptions:

1. Curb ramps.
2. Ramps that serve an individual dwelling unit may have one handrail, except that ramps open on one or both sides shall have handrails provided on the open side or sides.

1122A.5.2 Handrail configuration.

1122A.5.2.1 Handrail heights. The top of handrails shall be 34 to 38 inches (864 to 965 mm) above the ramp surface.

1122A.5.2.2 Handrail ends. Handrail ends shall be returned.

1122A.5.2.3 Handrail extension. Handrails shall extend a minimum of 12 inches (305 mm) beyond the top and bottom of the ramp. Where the extension creates a hazard, the termination of the extension shall be rounded or returned smoothly to floor, wall or post. (See Figure 11A-5A).

1122A.5.2.4 Handrail projections. Handrails projecting from a wall shall have a space of 1½ inches (38.1 mm) between the wall and the handrail.

Handrails may be located in a recess if the recess is a maximum of 3 inches (76.2 mm) deep and extends at least 18 inches (457 mm) above the top of the rail. Any wall or other surface adjacent to the handrail shall be free of sharp or abrasive elements. (See Figure 11A-6B).

1122A.5.2.5 Handrail grips. The handgrip portion of handrails shall not be less than 1¼ inches (31.75 mm) nor more than 2 inches (50.8 mm) in cross-sectional dimension or the shape shall provide an equivalent grip-

ping surface. The handgrip portion of handrails shall have a smooth surface with no sharp corners. Edges shall have a minimum radius of 1/8 inch (3.17 mm). Handrails shall not rotate within their fittings. (See Figure 11A-6B).

Note: For public use areas, public accommodations, and housing which is publicly funded, see Chapter 11B, Division III, Section 1133B.5.5 for provisions of the Division of the State Architect—Access Compliance (DSA-AC).

1122A.6 Curbs and wheel guides. Ramps exceeding 10 feet (3048 mm) in length, and ramp landings having a vertical drop exceeding 4 inches, shall be provided with one of the following:

1. Guide curbs a minimum of 2 inches (50.8 mm) in height at each side; or
2. Wheel guide rails at each side, centered 2 to 4 inches (50.8 to 101.6 mm) above the surface of the ramp or ramp landing.

Exception: Ramps or ramp landings bounded by a wall or fence.

Note: See Figure 11A-5A.

SECTION 1123A INTERIOR STAIRWAYS

1123A.1 General. Interior stairways serving buildings containing covered multifamily dwelling units shall comply with this section.

Note: This section shall not apply to interior stairways serving floors or dwelling units not required to be accessible.

1123A.2 Open risers. Open risers shall not be permitted on interior stairways.

Exception: Stairways within an individual dwelling unit.

1123A.3 Treads. All tread surfaces shall be slip resistant. Treads shall have smooth, rounded or chamfered exposed edges and no abrupt edges at the nosing (lower front edge).

1123A.4 Nosing. Nosing shall not project more than 1¼ inches (31.8 mm) past the face of the riser below. Risers shall be sloped or the underside of the nosing shall have an angle not more than 30 degrees (0.52 rad) from the vertical. (See Figure 11A-6A)

1123A.5 Striping for the visually impaired. Interior stairs shall have the upper approach and lower tread marked by a stripe providing clear visual contrast.

Exception: Stairways within an individual dwelling unit.

The stripe shall be a minimum of 2 inches (50.8 mm) wide to a maximum of 4 inches (101.6 mm) wide placed parallel to, and not more than 1 inch (25.4 mm) from, the nose of the step or upper approach. The stripe shall extend the full width of the step or upper approach and shall be of material that is at least as slip resistant as the other treads of the stair. A painted stripe shall be acceptable.

1123A.6 Interior stairway handrails.

1123A.6.1 Where required. Stairways shall have handrails on each side. Intermediate handrails shall be located equi-

distant from the sides of the stairway and comply with Section 1012.8.

Exception: Stairways serving an individual dwelling unit may have one handrail, except that stairways open on one or both sides shall have handrails on the open side or sides.

1123A.6.2 Handrail configuration.

1123A.6.2.1 Handrail heights. The top of handrails shall be 34 to 38 inches (864 to 965 mm) above the nosing of the treads.

1123A.6.2.2 Handrail ends. Ends shall be returned or shall terminate in newel posts or safety terminals.

1123A.6.2.3 Handrail extension. Handrails shall extend a minimum of 12 inches (305 mm) beyond the top nosing and 12 inches (305 mm), plus the tread width, beyond the bottom nosing. Where the extension creates a hazard, the termination of the extension shall be rounded or returned smoothly to floor, wall or post. Where the stairs are continuous from landing to landing, the inner rail shall be continuous and need not extend out into the landing. (See Figures 11A-6A and 11A-6E).

Exception: Stairways within an individual dwelling unit.

1123A.6.2.4 Handrail projections. Handrails projecting from a wall shall have a space of 1½ inches (38.1 mm) between the wall and the handrail.

Handrails may be located in a recess if the recess is a maximum of 3 inches (76.2 mm) deep and extends at least 18 inches (457 mm) above the top of the rail. Any wall or other surface adjacent to the handrail shall be free of sharp or abrasive elements. (See Figure 11A-6B).

1123A.6.2.5 Handrail grips. The handgrip portion of handrails shall not be less than 1¼ inches (31.75 mm) nor more than 2 inches (50.8 mm) in cross-sectional dimension or the shape shall provide an equivalent gripping surface. The handgrip portion of handrails shall have a smooth surface with no sharp corners. Edges shall have a minimum radius of 1/8 inch (3.17 mm). Handrails shall not rotate within their fittings. (See Figure 11A-6B).

Note: For public use areas, public accommodations, and housing which is publicly funded, see Chapter 11B, Division III, Section 1133B.4.2.6 for provisions of the Division of the State Architect—Access Compliance (DSA-AC).

SECTION 1124A ELEVATORS AND PLATFORM (WHEELCHAIR) LIFTS

1124A.1 General. Elevators provided in covered multifamily buildings shall be accessible and comply with this chapter, and Title 24, Part 7 of the California Code of Regulations.

Exception: Private elevators serving only one dwelling unit.

1124A.2 Location. Passenger elevators shall be located on a major accessible route and provisions shall be made to ensure

that they remain accessible and usable at all times that the building is occupied.

1124A.3 Size of cab and control locations.

1124A.3.1 General. Elevators serving covered multifamily buildings shall be sized to accommodate a wheelchair in accordance with this section.

Exception: When the enforcing agency determines that compliance with any requirement of this section would create an unreasonable hardship, an exception to the requirement shall be granted when equivalent facilitation is provided, and where it can be demonstrated that a person using a wheelchair can enter and operate the elevator.

1124A.3.2 Car inside. The car inside shall allow for the turning of a wheelchair. The minimum clear distance between walls or between wall and door, excluding return panels, shall not be less than 80 inches by 54 inches (2032 mm by 1372 mm) for center-opening doors, and 68 inches by 54 inches (1727 mm by 1372 mm) for side-slide opening doors. (See Figure 11A-7A). Minimum distance from wall to return panel shall not be less than 51 inches (1295 mm).

1124A.3.2.1 Door size. Elevator doors shall provide a minimum clear width of 36 inches (914 mm).

1124A.3.3 Car controls.

1124A.3.3.1 Car control location. Elevator floor buttons shall be within 54 inches (1372 mm) above the finish floor for side approach and 48 inches (1219 mm) for front approach. Except for photoelectric tube bypass switches, emergency controls, including the emergency stop and alarm, shall be grouped in or adjacent to the bottom of the panel and shall be no lower than 35 inches (889 mm) from the floor. For multiple controls only, one set must comply with these height requirements. Floor buttons shall be provided with visual indicators to show when each call is registered. The visual indicators shall be extinguished when each call is answered.

Note: Where possible, a 48-inch (1219 mm) maximum height for elevator floor buttons is preferred.

1124A.3.3.2 Car control buttons. Passenger elevator car controls shall have a minimum dimension of 3/4 inch (19.1 mm) and shall be raised 1/8 inch (3.2 mm) plus or minus 1/32 inch (0.8 mm) above the surrounding surface.

Control buttons shall be illuminated, shall have square shoulders and shall be activated by a mechanical motion that is detectable.

All control buttons shall be designated by a 5/8-inch-minimum (15.9 mm) raised characters and standard raised symbols that comply with Sections 1143A.8 and 1143A.9 immediately to the left of the control button. Contracted Grade 2 Braille that conforms to Section 1143A.9 shall be located immediately below the numeral, character or symbol. A minimum clear space of 3/8 inch (9.5 mm) or other suitable means of separation shall be provided between rows of control buttons. (See Figure 11A-7B.)

The raised characters and symbols shall be white on a black background. Controls and emergency equipment identified by raised symbols shall include, but not be limited to, “door open”, “door close”, “alarm bell”, “emergency stop” and “telephone.” The call button for the main entry floor shall be designated by a raised star at the left of the floor designation.

1124A.3.4 Emergency telephone. The emergency telephone handset shall be positioned no higher than 48 inches (1219 mm) above the floor, and the handset cord shall be a minimum of 29 inches (737 mm) in length. If the telephone system is located in a closed compartment, the compartment door hardware shall be a lever type conforming to the provisions of Section 1003.3.1.8. Emergency intercommunication shall not require voice communication.

1124A.4 Hall call buttons. Call operation buttons shall be centered 42 inches (1067 mm) above the floor. Buttons shall be a minimum of $\frac{3}{4}$ -inch (19.1 mm) in size and shall be raised $\frac{1}{8}$ -inch (3.2 mm) plus or minus $\frac{1}{32}$ -inch (0.8 mm) above the surrounding surface. The button designating the “Up” direction shall be on top.

Visual indication shall be provided to show each call registered and extinguished when answered. Objects adjacent to, and below, hall call buttons shall not project more than 4 inches (101.6 mm) from the wall. Hall call buttons shall be internally illuminated with a white light over the entire surface of the button.

1124A.5 Minimum illumination. The minimum illumination at the car controls threshold and the landing when the car and landing doors are open shall not be less than 5 foot-candles (54 lx).

1124A.6 Hall lantern. A visual and audible signal shall be provided at each hoistway entrance indicating to the prospective passenger the car answering the call and its direction of travel as follows:

1. The visual signal for each direction shall be a minimum of $2\frac{1}{2}$ inches (63.5 mm) high by $2\frac{1}{2}$ inches (63.5 mm) wide, and visible from the proximity of the hall call button.
2. The audible signal shall sound once for the “up” direction and twice for the “down” direction or of a configuration which distinguishes between up and down elevator travel.
3. The center line of the fixture shall be located a minimum of 6 feet (1829 mm) in height from the lobby floor.
4. The use of in-car lanterns, located in or on the car doorjamb, visible from the proximity of the hall call buttons and conforming to the above requirements of this section shall or will be acceptable.

Note: The use of arrow shapes are preferred for visible signals.

1124A.7 Door delay.

1124A.7.1 Hall call. The minimum acceptable time from notification that a car is answering a call (lantern and audible signal) until the doors of the car start to close shall be

calculated by the following equations but shall be no less than 5 seconds:

$$T = D / (1.5 \text{ ft/s}) \text{ or } T = D / (445 \text{ mm/s})$$

Where T is the total time in seconds and D is the distance from a point in the lobby or landing area 60 inches (1524 mm) directly in front of the farthest call button controlling that car to the centerline of its hoistway door (see Figure 11A-7D). For cars with in-car lanterns, T begins when the lantern is visible from the vicinity of hall call buttons and an audible signal is sounded.

1124A.7.2 Door delay for car calls. The minimum acceptable time for the door to remain fully open after receiving a call shall not be less than 5 seconds.

1124A.8 Doorjamb marking. All elevator hoistway entrances shall have raised floor number designations provided on both jambs. Characters shall be raised Arabic numerals a minimum of 2 inches (50.8 mm) in height with raised Braille symbols placed below the corresponding raised characters. The raised characters shall be on a contrasting background with the centerline of the characters 60 inches (1524 mm) from the floor. Braille symbols shall conform to Sections 1117B.5.5 and 1117B.5.6. On the grade level, a raised five-pointed star shall be placed to the left of the raised character. The outside diameter of the star shall be 2 inches (50.8 mm). Braille shall be placed below the corresponding raised characters (see Figure 11A-7C).

1124A.9 Door protective and reopening devices. Doors closed by automatic means shall be provided with a door-reopening device that will function to stop and reopen a car door and adjacent hoistway door in case the car door is obstructed while closing.

This reopening device shall also be capable of sensing an object or person in the path of a closing door without requiring contact for activation at a nominal 5 inches and 29 inches (127 mm and 737 mm) above the floor.

Door-reopening devices shall remain effective for a period of not less than 20 seconds. After such an interval, the doors may close in accordance with the requirements of ANSI 17.1-86 and the American Society of Mechanical Engineers (ASME) document ASME 17.1-1990.

1124A.10 Operation and leveling. The elevator shall be automatic and be provided with a self-leveling feature that will automatically bring the car to the floor landings within a tolerance of plus or minus $\frac{1}{2}$ inch (12.7 mm) under rated loading to zero loading conditions. This self-leveling shall, within its zone, be entirely automatic and independent of the operating device and shall correct the overtravel or undertravel. The car shall also be maintained approximately level with the landing, irrespective of load.

The clearance between the car platform sill and the edge of the hoistway landing shall be no greater than $1\frac{1}{4}$ inches (31.75 mm).

1124A.11 Platform (wheelchair) lifts. Platform (wheelchair) lifts may be provided between levels, in lieu of passenger elevators, when the vertical distance between landings, as well as the structural design and safeguards are as allowed by ASME A18.1, Safety Standard for Platform Lifts and Stairway Chair Lifts; the State of California, the Department of Industrial

Relations, Division of Occupational Safety and Health and any applicable safety regulations of other administrative authorities having jurisdiction.

If lifts are provided, they shall be designed and constructed to facilitate unassisted entry, operation and exit from the lift, and shall comply with restrictions and enhancements of this section in conjunction with Title 8 of the California Code of Regulations.

SECTION 1125A HAZARDS ON ACCESSIBLE ROUTES

1125A.1 Warning curbs. Abrupt changes in level exceeding 4 inches (101.6 mm) in vertical dimension, such as changes in level at planters or fountains located in or adjacent to walks, halls, corridors, passageways, aisles, pedestrian ways and other circulation spaces shall be identified by curbs projecting at least 6 inches (152.4 mm) in height above the walk or sidewalk surface to warn the blind of a potential drop-off.

Exception: When a guardrail or handrail is provided with a wheel guide centered 2 to 4 inches (50.8 to 101.6 mm) above the surface of the walk or sidewalk.

1125A.2 Headroom clearance. Walks, halls, corridors, passageways, aisles, pedestrian ways and other circulation spaces which are part of the required egress system shall have a minimum clear headroom of 84 inches (2134 mm). Other walks, pedestrian ways and circulation spaces shall have a minimum clear headroom of 80 inches (2032 mm). If the vertical clearance of an area adjoining an accessible route is reduced to less than 80 inches (2032 mm) nominal dimension, a guardrail or other barrier having its leading edge at or below 27 inches (686 mm) above the finished floor shall be provided. (See Figure 11A-1B).

Exception: Doorways and archways less than 24 inches (610 mm) in depth may have a minimum clear headroom of 80 inches (2032 mm) nominal. (See Section 1126A).

1125A.3 Overhanging obstructions. Any obstruction that overhangs a pedestrian way shall be a minimum of 80 inches (2032 mm) above the walking surface as measured from the bottom of the obstruction. Where a guy support is used parallel to a path of travel, including, but not limited to, sidewalks, a guy brace, sidewalk guy or similar device shall be used to prevent an overhanging obstruction (see Section 1125A.2 for required headroom clearance).

1125A.4 Free-standing signs. Wherever signs mounted on posts or pylons protrude from the posts or pylons and the bottom edge of the sign is less than 80 inches (2032 mm) above the finished floor or ground level, the edges of such signs shall be rounded or eased and the corners shall have a minimum radius of 0.125 inches. (See Section 1125A.2 for required headroom clearance).

SECTION 1126A DOORS

1126A.1 Width and height of doors. Doorways which provide access to common use areas or covered multifamily dwellings shall comply with the following:

1. Permit the installation of a door not less than 36 inches (914 mm) in width, not less than 80 inches (2032 mm) in height and provide a clear width of not less than 32 inches (813 mm), measured with the door positioned at an angle of 90 degrees from its closed position.
2. Be capable of opening at least 90 degrees.
3. A pair of doors, manual or automatic, must have at least one leaf which provides a clear width of not less than 32 inches (813 mm), measured with the door positioned at an angle of 90 degrees from its closed position.
4. The width of any component in the egress system shall not be less than the minimum width required by Section 1003.2.3.

Revolving doors shall not be used as required entrances for persons with disabilities.

1126A.2 Level floor or landing. The floor or landing on each side of an exit door shall be level. (See Chapter 10).

1126A.2.1 Thresholds and changes in elevation at doors. The floor or landing shall not be more than ½ inch (12.7 mm) lower than the top of the threshold of the doorway. (See Figure 11A-8I).

Changes in level between ¼ inch (6.35 mm) and ½ inch (12.7 mm) shall be beveled with a slope no greater than 1 unit vertical in 2 units horizontal (50% slope). Changes in level greater than ½ inch (12.7 mm) shall be accomplished by means of a ramp (see Section 1122A).

1126A.3 Maneuvering clearances at doors.

1126A.3.1 General. The level floor or landing of an exit door shall have a length in the direction of the door swing of at least 60 inches (1524 mm) and a length opposite the direction of the door swing of at least 44 inches (1118 mm) measured at right angles to the plane of the door in its closed position. (See Figures 11A-8D, 11A-8E and 11A-8F for maneuvering spaces at sliding doors).

1126A.3.2 Strike edge maneuvering space. The width of the level area on the side to which the door swings shall extend at least 24 inches (610 mm) past the strike edge of the door for exterior doors and at least 18 inches (457 mm) past the strike edge for interior doors.

Note: Twenty-four inches (610 mm) is preferred for strike-side clearance.

1126A.3.2.1 Front approach. The following provisions shall apply to swinging doors with front approach:

1. For pull side approach, the level floor or landing shall extend in the direction of the door swing at least 60 inches (1524 mm). (See Figure 11A-8A).
2. For push side approach, the level floor or landing shall extend opposite the direction of the door swing at least 48 inches (1219 mm). (See Figure 11A-8A).
3. Doors with push side approach having both a closer and a latch shall be provided with a clear and level area extending a minimum of 12 inches (305 mm) past the strike edge on the approach side of the door. (See Figure 11A-8A).

1126A.3.2.2 Hinge side approach. The following provisions shall apply to swinging doors with hinge side approach:

1. Doors with pull side approach shall be provided with a level floor or landing not less than 60 inches (1524 mm) in depth. A clear and level area shall extend a minimum of 36 inches (914 mm) past the strike edge on the approach side of the door. (See Figure 11A-8B).

Exception: Doors with pull side approach and a level floor or landing greater than 60 inches (1524 mm) in depth shall be provided with a clear and level area at least 24 inches (610 mm) past the strike edge of the door for exterior doors and at least 18 inches (457 mm) past the strike edge for interior doors.

2. Doors with push side approach shall have a level floor or landing not less than 44 inches (1118 mm) in depth, and shall be provided with a clear and level area extending a minimum of 54 inches (1372 mm) from the strike edge of the door jamb past the hinge side of the door. Doors with a latch and closer shall have a level floor or landing not less than 48 inches (1219 mm) depth at the push side of the door. (See Figure 11A-8B).

1126A.3.2.3 Latch side approach. The following provisions shall apply to swinging doors with latch side approach:

1. Doors with pull side approach shall have a level floor or landing not less than 60 inches (1524 mm) in depth, and shall be provided with a clear and level area extending a minimum of 24 inches (610 mm) past the strike edge on the approach side of the door. (See Figure 11A-8C).

Exception: Doors serving individual covered multifamily dwelling units shall have a minimum landing depth of 44 inches (1118 mm) except that doors with a closer shall have a minimum landing depth of 54 inches (1372 mm).

2. Doors with push side approach shall have a level floor or landing not less than 44 inches (1118 mm) in depth, and shall be provided with a clear and level area extending a minimum of 24 inches (610 mm) past the strike edge on the approach side of the door. Doors with a closer shall have a level floor or landing not less than 48 inches (1219 mm) depth at the push side of the door. (See Figure 11A-8C).

1126A.3.3 Space between consecutive doors. The minimum space between two hinged or pivoted doors in series, serving other than a required exit stairway, shall provide a minimum of 48 inches (1219 mm) plus the width of the door swinging into the space. Doors in a series shall swing either in the same direction or away from the space between the doors. (See Figure 11A-8G, and 11A-8H).

Where the door opens into a stair or smokeproof enclosure, the landing need not have a minimum length of 60 inches (1524 mm). (See Figure 11A-8H).

1126A.4 Closer-effort to operate doors. Maximum effort to operate doors shall not exceed 8½ pounds (38 N) for exterior doors and 5 pounds (22 N) for interior doors, such pull or push effort being applied at right angles to hinged doors and at the center plane of sliding or folding doors. Compensating devices or automatic door operators may be utilized to meet these standards. When fire doors are required, the maximum effort to operate the door may be increased to the minimum allowable by the appropriate enforcement agency, not to exceed 15 pounds (66.7 N).

1126A.4.1 Door closer. If the door has a closer, then the sweep period of the closer shall be adjusted so that from an open position of 70 degrees, the door will take at least 3 seconds to move to a point 3 inches (75 mm) from the latch, measured to the landing edge of the door.

1126A.5 Type of lock or latch. The type of latch and lock required for all doors shall be in accordance with Chapter 10, Section 1003.3.1.8.

1126A.6 Hand-activated door hardware. Hand-activated door latching, locking and opening hardware shall be centered between 30 inches (762 mm) and 44 inches (1118 mm) above the floor. Latching and locking doors that are hand-activated and on an accessible route shall be operable with a single effort by lever type hardware, panic bars, push-pull activating bars or other hardware designed to provide passage without requiring the ability to grasp the opening hardware. Locked exit doors shall operate consistent with Section 1126A.4, in the direction of egress.

1126A.6.1 Lever type hardware. The lever or lever of actuated latches or locks shall be curved with a return to within ½ inch (12.7 mm) of the door to prevent catching on the clothing of persons during egress.

Exception: Group R and U occupancies with an occupant load of 10 or less.

1126A.7 Smooth surface. The bottom 10 inches (254 mm) of all doors and/or gates shall have a smooth, uninterrupted surface to allow the door or gate to be opened by a wheelchair footrest without creating a trap or hazardous condition. Where narrow frame doors are used, a 10-inch high (254 mm) smooth panel shall be installed on the push side of the door, which will allow the door to be opened by a wheelchair footrest without creating a trap or hazardous condition. (See Figure 11A-8J).

Exception: Automatic and sliding doors or gates.

SECTION 1127A COMMON USE FACILITIES

Note: For public use facilities, see Chapter 11B of this code.

1127A.1 General. When provided, common use areas and facilities in covered multifamily housing developments shall be accessible to persons with disabilities. Common use facilities include, but are not limited to, lobbies, toilet and bathing facilities, laundry facilities, community rooms, clubhouses, health and fitness facilities, game rooms and portions of common use

6. **Lavatory Faucet Controls.** Faucet controls and operation mechanisms shall be operable with one hand and shall not require tight grasping, pinching or twisting of the wrist.

The force required to activate controls shall be no greater than 5 pound-force (lbf) (22.2N). Lever operated, push type and electronically controlled mechanisms are examples of acceptable designs. Self-closing valves are allowed if the faucet remains open for at least 10 seconds.

1127A.4 Grab bars, tub and shower seats, fasteners and mounting devices.

1127A.4.1 General. Grab bars, tub and shower seats, fasteners and mounting devices required by this chapter shall comply with this section.

1127A.4.2 Location. Grab bars which are located on each side, or on one side and the back, of the accessible toilet stall or compartment shall be securely attached and centered 33 inches (838 mm) above and parallel to the floor; except that, where a tank-type toilet obstructs placement at 33 inches (838 mm), the grab bar may be centered as high as 36 inches (914 mm). The space between the grab bar and objects below shall be a minimum of 1½ inches (38.1 mm). Grab bars shall be at least 42 inches (1067 mm) in length with the front end positioned 24 inches (610 mm) in front of the water closet stool. Grab bars at the back shall not be less than 36 inches (914 mm) in length. (See Figures 11A-9A and 11A-9B).

1127A.4.3 Diameter or width. The diameter or width of the gripping surfaces of a grab bar shall be 1¼ inches to 1½ inches (31.75 mm to 38.1 mm) or of a shape that provides an equivalent gripping surface. If grab bars are mounted adjacent to a wall, the space between the wall and the grab bars shall be 1½ inches (38.1 mm). (See Figure 11A-9C).

1127A.4.4 Structural strength. The structural strength of grab bars, tub and shower seats, fasteners, and mounting devices shall meet the following specifications:

1. Bending stress in a grab bar or seat induced by the maximum bending moment from the application of a 250-pound (1112 N) point load shall be less than the allowable stress for the material of the grab bar or seat.
2. Shear stress induced in a grab bar or seat by the application of a 250-pound (1112N) point load shall be less than the allowable shear stress for the material of the grab bar or seat, and if its mounting bracket or other support is considered to be fully restrained, then direct and torsional shear stresses shall not exceed the allowable shear stress.
3. Shear force induced in a fastener or mounting device from the application of a 250-pound (1112 N) point load shall be less than the allowable lateral load of either the fastener or mounting device or the supporting structure, whichever is the smaller allowable load.
4. Tensile force induced in a fastener by a direct tension force of a 250-pound (1112 N) point load, plus the maximum moment from the application of a 250-pound (1112 N) point load, shall be less than the

allowable withdrawal load between the fastener and supporting structure.

5. Grab bars shall not rotate within their fittings.

1127A.4.5 Surface. A grab bar and any wall or other surface adjacent to it shall be free of any sharp or abrasive elements. Edges shall have a minimum radius of 1/8 inch (3.17 mm).

1127A.5 Bathing facilities.

1127A.5.1 General. When common use bathing facilities are provided for residents or guests, including showers, bathtubs or lockers, at least one of each type of fixture in each facility, and not less than 1 percent of all fixtures, shall comply with this section.

1127A.5.2 Bathtubs. Bathtubs required to be accessible shall comply with the following:

1. **Floor Space.** Clear floor space at bathtubs shall be as shown in Figure 11A-9E.
2. **Seat.** An in-tub seat or a seat at the head end of the tub shall be provided as shown in Figures 11A-9E and 11A-9F. The structural strength of seats and their attachments shall comply with Section 1127A.4.4. Seats shall be mounted securely and shall not slip during use.
3. **Grab Bars.** Grab bars complying with Sections 1127A.4.3, 1127A.4.4 and 1127A.4.5 shall be provided as shown in Figures 11A-9F and 11A-9G.
4. **Controls.** Faucets and other controls shall be located as shown in Figure 11A-9F. They shall be operable with one hand and shall not require tight grasping, pinching or twisting of the wrist. The force required to activate controls shall be no greater than a 5 pound force (lbf) (22.2 N).
5. **Shower Spray Unit.** A shower spray unit with a hose at least 60 inches (1524 mm) long that can be used both as a fixed shower head and as a hand-held shower shall be provided.
6. **Bathtub Enclosures.** If provided, enclosures for bathtubs shall not obstruct controls or transfer from wheelchairs onto bathtub seats or into tubs. Enclosures on bathtubs shall not have tracks mounted on their rims.

1127A.5.3 Showers. Showers required to be accessible shall comply with the following:

1. **Size.** Showers shall be consistent with one of the following: (1) 60 inches (1524 mm) minimum in width between wall surfaces and 30 inches (762 mm) minimum in depth with a full opening width on the long side; or (2) 42 inches (1067 mm) in width between wall surfaces and 48 inches (1219 mm) minimum in depth with an entrance opening of 42 inches (1067 mm); or (3) showers 60 inches (1524 mm) minimum in width may be 36 inches (914 mm) minimum in depth as long as the entrance opening width is a minimum 36 inches (914 mm).
2. **Thresholds.** When a threshold or recessed drop is permitted, it shall be a maximum of ½ inch (12.7 mm) in height and shall be beveled or sloped at an angle

not exceeding 45 degrees (100 percent gradient) from the horizontal.

3. **Multiple Showers.** Where, within the same functional area, two or more accessible showers are provided, there shall be at least one shower constructed opposite hand from the other or others (i.e., one left-hand control versus right-hand controls).
4. **Accessories.** Shower accessories shall include:
 - 4.1. **Water Controls.** Water controls of a single-lever design shall be located on the side wall of the compartment adjacent to the seat and operable with a maximum force of 5 pounds (22.2 N), mounted at 40 inches (1016 mm) [plus or minus 1 inch (25.4 mm) tolerance] above the shower floor. The centerline of the controls shall be within a reach range of no less than 18 inches (457 mm) and no more than 24 inches (610 mm) from the rear edge of the seat.
 - 4.2. **Hand-held Sprayer Unit.** A flexible hand-held sprayer unit with a hose at least 60 inches (1524 mm) long shall be provided within reach range of the seat at a distance not to exceed 27 inches (686 mm) horizontally measured from the rear seat edge to the centerline of the mounting bracket. This unit shall be mounted at a maximum height of 48 inches (1219 mm) [plus or minus 1 inch (25.4 mm) tolerance] above the shower floor.
 - 4.3. **Sprayer Unit Alternative.** Where accessible shower facilities are provided in areas subject to excessive vandalism, in lieu of providing the fixed flexible hose, two wall-mounted shower heads shall be installed. Each shower head shall be installed so that it can be operated independently of the other and shall have swivel angle adjustments, both vertically and horizontally. One shower head shall be located at a height of 48 inches (1219 mm) [plus or minus 1 inch (25.4 mm) tolerance] above the floor.
 - 4.4. **Floor Slope.** The maximum slope of the floor shall be 2 percent per foot in any direction. Where drains are provided, grate openings shall be a maximum of $\frac{1}{4}$ inch (6.35 mm) and located flush with the floor surface.
5. **Shower Fixtures.** Shower fixtures shall include:
 - 5.1. A folding seat located within 27 inches (686 mm) of the controls, mounted 18 inches (457 mm) above the floor and with a minimum space of 1 inch (25.4 mm) and maximum space of $1\frac{1}{2}$ inches (38.1 mm) allowed between the edge of the seat and any wall. When folded, the seat shall not extend more than 6 inches (152.4 mm) from the mounting wall. (See Figures 11A-9H, 11A-9I, 11A-9J and 11A-9K).
 - 5.2. Grab bars located on walls adjacent to and opposite the seat. Grab bars shall comply with

the diameter, loading and projection requirements of Sections 1127A.4.3, 1127A.4.4 and 1127A.4.5. Grab bars shall be mounted between a minimum of 33 inches (838 mm) and a maximum of 36 inches (914 mm) above the shower floor with an L-shaped grab bar mounted on walls opposite and adjacent to the front edge of the seat, but not extended to include that portion of wall over the seat. (See Figure 11A-9H or 11A-9I).

6. **Soap Dish.** When a soap dish is provided, it shall be located on the control wall at a maximum height of 40 inches (1016 mm) above the shower floor, and within reach limits from the seat.
7. **Enclosures.** Enclosures, when provided for shower stalls, shall not obstruct transfer from wheelchairs onto shower seats.

Note: See Figures 11A-9H, 11A-9I, 11A-9J and 11A-9K.

1127A.5.3.1 Open showers. Where no separate shower compartments are provided, the shower for persons with disabilities shall be located in a corner with L-shaped grab bars extending along two adjacent walls with a folding seat adjacent to the shower controls. (See Figures 11A-9H, 11A-9I, 11A-9J and 11A-9K).

1127A.6 Lockers.

1127A.6.1 General. Where lockers are provided for residents or guests, at least one locker and not less than 1 percent of all lockers shall be accessible to persons with disabilities. A path of travel not less than 36 inches (914 mm) in clear width shall be provided to these lockers. See Section 1127A.9 for required clear space, allowable reach ranges and requirements for control and operating mechanisms.

1127A.7 Signs.

1127A.7.1 General. All accessible toilet and bathing facilities shall be identified by the "International Symbol of Accessibility." Signs need not be provided for facilities within a dwelling unit or guestroom.

1127A.7.2 Identification symbols. Doorways leading to sanitary facilities shall be identified by a geometric symbol in compliance with this section. Geometric symbols shall be centered horizontally on the door at a height of 60 inches (1524 mm) above the finish floor or ground surface measured to the center of the symbol. Edges of accessibility signage shall be rounded, chamfered or eased. Corners shall have a minimum radius of $\frac{1}{8}$ inch (3.2 mm). See Section 1143A.10, Item 1, for additional signage requirements applicable to sanitary facilities.

1127A.7.2.1 Men's sanitary facilities. Men's sanitary facilities shall be identified by an equilateral triangle, $\frac{1}{4}$ inch (6.4 mm) thick with edges 12 inches (305 mm) long and a vertex pointing upward. The triangle symbol shall contrast with the door, either light on a dark background or dark on a light background.

1127A.7.2.2 Women's sanitary facilities. Women's sanitary facilities shall be identified by a circle, $\frac{1}{4}$ inch (6.4

mm) thick and 12 inches (305 mm) in diameter. The circle symbol shall contrast with the door, either light on a dark background or dark on a light background.

1127A.7.2.3 Unisex sanitary facilities. Unisex sanitary facilities shall be identified by a circle, 1/4 inch (6.4 mm) thick and 12 inches (305 mm) in diameter with a 1/4 inch (6.4 mm) thick triangle superimposed on the circle and within the 12-inch (305 mm) diameter. The triangle symbol shall contrast with the circle symbol, either light on a dark background or dark on a light background. The circle symbol shall contrast with the door, either light on a dark background or dark on a light background.

1127A.8 Toilet room fixtures and accessories.

1127A.8.1 Towel, sanitary napkins, waste receptacles. Where towel, sanitary napkins, waste receptacles and other similar dispensing and disposal fixtures are provided, at least one of each type shall be located with all operable parts, including coin slots, within 40 inches (1016 mm) from the finished floor. Controls and operating mechanisms shall comply with Section 1127A.9.6.4.

1127A.8.2 Toilet tissue dispensers. Toilet tissue dispensers shall be located on the wall within 12 inches (305 mm) of the front edge of the toilet seat. Dispensers that control delivery or that do not permit continuous paper flow shall not be used. (See Figure 11A-9B).

1127A.8.3 Mirrors. Where mirrors are provided, at least one shall be accessible. Mirrors shall be mounted with the bottom edge no higher than 40 inches (1016 mm) from the floor.

1127A.9 Space allowances and reach ranges in common use areas.

1127A.9.1 Wheelchair passage width. The minimum clear width for single wheelchair passage shall be 36 inches (914 mm) continuously. (See Figure 11A-1E).

Exception: Thirty-two inches (813 mm) in width is acceptable at a point not to exceed 24 inches (610 mm) in length.

1127A.9.2 Width for wheelchair passing. The minimum width for two wheelchairs to pass is 60 inches (1524 mm) (see Figure 11A-1F).

1127A.9.3 Wheelchair turning space. The space required for a wheelchair to make a 180-degree turn is a clear space of 60 inches (1524 mm) diameter (See Figure 11A-1D(a) or a T-shaped space, see Figure 11A-1D(b)).

1127A.9.4 Clear floor or ground space for wheelchairs.

1127A.9.4.1 Size and approach. The minimum clear floor or ground space required to accommodate a single, stationary wheelchair and occupant is 30 inches by 48 inches (762 mm by 1219 mm). (See Figure 11A-1G.) The minimum clear floor or ground space for wheelchairs may be positioned for forward or parallel approach to an object (See Figure 11A-1G). Clear floor or ground space for wheelchairs may be part of the knee space required under some objects.

1127A.9.4.2 Relationship of maneuvering clearances to wheelchair spaces. One full unobstructed side of the

clear floor or ground space for a wheelchair shall adjoin or overlap an accessible route or adjoin another wheelchair clear floor space. If a clear floor space is located in an alcove or otherwise confined on all or a part of three sides, additional maneuvering clearances shall be provided as shown in Figure 11A-1H.

1127A.9.4.3 Surfaces of wheelchair spaces. Clear floor or ground spaces for wheelchairs shall comply with Sections 1119A.2, 1120A.3 and 1121A.

1127A.9.4.3.1 Gratings. Gratings located in ground and floor surfaces along accessible routes shall be limited to spaces no greater than 1/2-inch (12.7 mm) wide in one direction. If gratings have elongated openings, they shall be placed so that the long dimension is perpendicular to the dominate direction of traffic.

1127A.9.5 Reach ranges.

1127A.9.5.1 Forward reach. If the clear floor space allows only forward approach to an object, the maximum high forward reach allowed shall be 48 inches (1219 mm) and the minimum low forward reach shall be unobstructed and no less than 15 inches (381 mm) above the floor (see Figure 11A-1I(a)). If the high forward reach is over an obstruction, reach and clearances shall be as shown in Figure 11A-1I(b).

1127A.9.5.2 Side reach. If the clear floor space allows parallel approach by a person in a wheelchair, the maximum high side reach allowed shall be 54 inches (1372 mm) and the low side reach shall be no less than 9 inches (228.6 mm) above the floor (see Figure 11A-1J(a) and 11A-1J(b)). If the side reach is over an obstruction, the reach and clearances shall be as shown in Figure 11A-1J(c).

1127A.9.6 Controls and operating mechanisms.

Note: See also Section 1142A, for electrical installation.

1127A.9.6.1 General. Controls and operating mechanisms in accessible spaces, along accessible routes or as part of accessible elements (e.g., light switches and dispenser controls) shall comply with this section.

1127A.9.6.2 Clear floor space. Clear floor space complying with Section 1127A.9.4 that allows a forward or parallel approach by a person using a wheelchair shall be provided at controls, dispensers, receptacles and other operable equipment.

1127A.9.6.3 Height. Controls shall be located no higher than 48 inches (1219 mm), and no lower than 15 inches (381 mm), above the finished floor measured to the center of the grip. If the reach is over an obstruction (for example, washer or dryer) between 20 and 25 inches (508 and 635 mm) in depth, the maximum height is reduced to 44 inches (1118 mm) for forward approach, or 46 inches (1168 mm) for side approach, provided the obstruction is no more than 24 inches (610 mm) in depth. Controls that do not satisfy these specifications are acceptable, provided that comparable controls or outlets, that perform the same functions, are provided within the same area and are accessible.

1127A.9.6.4 Operation. Controls and operating mechanisms shall be operable with one hand and shall not require tight grasping, pinching or twisting of the wrist. The force required to activate controls shall be no greater than 5 pounds (22.2 N) of force.

1127A.10 Common accessible laundry rooms.

1127A.10.1 General. Where common use laundry rooms are provided, at least one of each type of appliance provided in each laundry area shall be accessible, shall be on an accessible route and shall comply with this section. Such appliances include clothes washing machines, dryers, soap dispensers and any related features such as wash sinks, tables and storage areas.

Where laundry rooms are provided on floors of an elevator building, each laundry room shall be accessible. Where there is one laundry room on a ground floor in each building, each laundry room shall be accessible. Where there is a laundry room on the ground floor of a building and another located in the basement, it is acceptable to have only the ground floor laundry room accessible.

1127A.10.2 Clear floor space. There shall be a minimum clear space 30 inches perpendicular by 48 inches parallel (762 mm by 1219 mm) in front of clothes washers and dryers required to be accessible.

There shall be a minimum clear space 30 inches by 48 inches (762 mm by 1219 mm) provided for at least one of each type of fixture or appliance provided in the laundry room (e.g. soap dispensers, wash sinks, tables, storage areas).

1127A.10.3 Controls. Clothes washers and dryers including stacked clothes washers and dryers required to be accessible shall have controls (including coin slots) within the reach range of a seated user. Controls shall be located no higher than 48 inches (1219 mm), and no lower than 15 inches (381 mm), above the finished floor measured to the center of the grip. If the reach is over an obstruction (for example, washer or dryer) between 20 and 25 inches (508 and 635 mm) in depth, the maximum height is reduced to 44 inches (1118 mm) for forward approach, or 46 inches (1168 mm) for side approach. Controls that do not satisfy these specifications are acceptable, provided that comparable controls or outlets, that perform the same functions, are provided within the same area and are accessible.

Controls shall be operable with one hand and not require tight grasping, pinching or twisting of the wrist.

1127A.10.4 Washing machines and clothes dryer. Washing machines and clothes dryers in accessible common use laundry rooms shall be front loading.

1127A.11 Storage.

1127A.11.1 General. If fixed storage facilities such as cabinets, shelves, closets or drawers are provided where access is required by Sections 108.2.1.2 and 1102A, at least one of each type of facility provided shall comply with this section. Additional storage may be provided outside of the reach ranges shown in Figure 11A-1J.

1127A.11.2 Clear floor space. A clear floor space at least 30 inches by 48 inches (762 mm by 1219 mm) complying

with Section 1127A.9.4 that allows either a forward or parallel approach by a person using a wheelchair shall be provided at accessible storage facilities.

1127A.11.3 Height. Accessible storage spaces shall be within at least one of the reach ranges specified in Section 1127A.9.5. Clothes rods shall be a maximum of 54 inches (1372 mm) from the floor for a side approach (see Figure 11A-1J). Where the distance from the wheelchair to the clothes rod or shelf exceeds 10 inches (254 mm), as in closets without accessible doors, the height and depth to the rod or shelf shall comply with Figure 11A-1J.

1127A.11.4 Hardware. Hardware for accessible storage facilities shall comply with Section 1127A.9.6. Touch latches and U-shaped pulls are acceptable.

1127A.12 Fixed or built-in seating, tables and counters

1127A.12.1 Minimum seating. Where fixed or built-in seating, tables or counters are provided for residents or guests, 5 percent, but not less than one, shall be accessible as provided in this section.

1127A.12.2 Seating. When seating spaces for persons in wheelchairs are provided at fixed tables or counters, clear floor space complying with Section 1127A.9.4 shall be provided. Such clear floor space shall not overlap knee space by more than 19 inches (483 mm). (See Figure 11A-1K).

1127A.12.3 Knee clearance. When seating for persons in wheelchairs is provided at fixed tables or counters, knee spaces at least 27 inches (686 mm) high, 30 inches (762 mm) wide and 19 inches (483 mm) deep shall be provided. (See Figure 11A-1K).

1127A.12.4 Height of work surfaces. The tops of tables and counters shall be 28 inches to 34 inches (711 mm to 864 mm) from the floor or ground.

Division IV—DWELLING UNIT FEATURES

Division IV Table of Contents

Section 1128A	Covered Dwelling Units
Section 1129A	Reserved
Section 1130A	Accessible Route within Covered Multifamily Dwelling Units
Section 1131A	Changes in Level on Accessible Routes
Section 1132A	Doors
Section 1133A	Kitchens
Section 1134A	Bathing and Toilet Facilities
Section 1135A	Laundry Rooms
Section 1136A	Electrical Receptacle, Switch and Control Heights

SECTION 1128A COVERED DWELLING UNITS

1128A.1 General. Covered multifamily dwelling units shall be adaptable and accessible into and throughout the dwelling unit as provided in this division.

Note: See Sections 1101A “Application” and 1102A “Building Accessibility” for dwelling units required to comply with this division.

SECTION 1129A Reserved

SECTION 1130A ACCESSIBLE ROUTE WITHIN COVERED MULTIFAMILY DWELLING UNITS

1130A.1 General. An accessible route shall be provided through all rooms and spaces of the dwelling unit. The accessible route shall pass through the primary entry door, and shall connect with all additional exterior doors, required clear floor spaces at kitchen appliances and bathroom fixtures. For the purpose of this section, “accessible routes” may include hallways, corridors and ramps.

Exception: An accessible route is not required from the interior of the unit into a basement or garage, except as provided in Section 1105A.1.

1130A.2 Width. The accessible route into and throughout covered multifamily dwelling units shall be at least 36 inches (914 mm) wide.

SECTION 1131A CHANGES IN LEVEL ON ACCESSIBLE ROUTES

1131A.1 Changes in level not exceeding 1/2 inch. Abrupt changes in level along any accessible route shall not exceed 1/2 inch (12.7 mm). When changes in level do occur, they shall be beveled with a slope no greater than 1 unit vertical in 2 units horizontal (50-percent slope). Changes in level not exceeding 1/4 inch (6.35 mm) may be vertical.

1131A.2 Changes greater than 1/2 inch. Changes in level greater than 1/2 inch (12.7 mm) shall be made by means of a ramp, elevator or platform (wheelchair) lift. See Section 1122A for ramps and Section 1124A.11 for platform (wheelchair) lifts.

SECTION 1132A DOORS

1132A.1 Primary entry doors and required exit doors. The primary entry door and all required exit doors shall comply with the requirements of this section. The requirements of Sections 1126A.3 shall apply to maneuvering clearances at the side of the door exposed to common or public use spaces (e.g. entry or exit doors which open from the covered multifamily dwelling unit into a corridor, hallway or lobby, or directly to the outside).

1132A.2 Interior doors and secondary exterior doors. Except as allowed by Section 1109A.2, doors intended for user passage and secondary exterior doors shall comply with this section. The provisions of this section shall apply to the dwelling unit side of doors leading from the interior of the dwelling unit to an unfinished basement or an attached garage.

1132A.3 Width and height of doors. Doors shall comply with the following:

1. Doors shall not be less than 6 feet 8 inches (2032 mm) in height.
2. Swinging doors shall provide a net clear opening width of not less than 32 inches (813 mm), measured with the

door or doors positioned at an angle of 90 degrees from the closed position. A 34-inch (864 mm) door is acceptable. The primary entry door and all required exit doors shall comply with the requirements of Section 1126A.1.

3. Swinging doors shall be capable of opening at least 90 degrees.
4. A nominal 32-inch (813 mm) clear opening provided by a standard 6-foot wide (1829 mm) sliding patio door assembly is acceptable.
5. A pair of doors, manual or automatic, must have at least one leaf which provides a clear width of not less than 32 inches (813 mm), measured with the door positioned at an angle of 90 degrees from its closed position.
6. The width of any component in the means of egress system shall not be less than the minimum width required by Section 1003.2.3.

1132A.4 Level floor or landing. See also Chapter 10, Section 1003.3.1.6.2. The floor or landing on each side of a door shall be level. Primary entry doors, required exit doors or secondary exterior doors with changes in height between the interior surface or floor level and the exterior surface or floor level shall comply with the following:

1. Exterior landings of impervious construction (e.g., concrete, brick, flagstone) serving primary entry doors and required exit doors are limited to not more than 1/2 inch (12.7 mm) of change in height between floor surfaces. Changes in level shall comply with Section 1131A.
2. Exterior landings of pervious construction (e.g., wood decking with spaces) shall be the same level as the interior landing, except that secondary exterior doors may have no more than 1/2 inch (12.7 mm) of change in height between floor surfaces. Changes in level shall comply with Section 1131A.
3. Secondary exterior doors onto decks, patios or balcony surfaces constructed of impervious materials (e.g., concrete, brick, flagstone) may have a maximum change in height from the interior landing of 4 inches (101.6 mm). Changes in height greater than 1/2 inch (12.7 mm) shall be accomplished by means of a ramp complying with Section 1114A or by means of a platform constructed to the level of the floor as illustrated in Figure 11A-8J.
4. Secondary exterior doors onto decks, patios or balcony surfaces constructed of impervious materials (e.g., concrete, brick, flagstone) may have a maximum change in height from the interior landing of 1 inch (25.4 mm), provided a ramp with a maximum slope of 1:8 is permanently installed. (See Figure 11A-8K.)
5. In buildings containing covered multifamily dwelling units, the floor or landing immediately outside the entry may be sloped up to 1/4 inch (6.35 mm) per foot (12 inches) (305 mm), in a direction away from the primary entrance of the dwelling unit for drainage.

1132A.4.1 Thresholds. Thresholds at the primary entry and required exit doors shall be no higher than 1/2 inch (12.7 mm). Thresholds at secondary exterior doors, including sliding door tracks, shall be no higher than 3/4 inch (19.05 mm). Changes in height at interior door thresholds (e.g. floor material changes at door thresholds) shall not exceed

$\frac{1}{2}$ inch (12.7 mm). Thresholds shall comply with the following:

1. Thresholds with a change in height of not more than $\frac{1}{4}$ inch (6.35 mm) may be vertical.
2. Thresholds with a change in height between $\frac{1}{4}$ inch (6.35 mm) and $\frac{3}{4}$ inch (19.05 mm) shall be beveled with a slope no greater than 1 unit vertical in 2 units horizontal (50-percent slope).

1132A.5 Maneuvering clearances at doors.

1132A.5.1 General. Maneuvering clearances at interior doors shall provide a minimum length on both sides of the door of at least 42 inches (1067 mm) measured at a right angle to the plane of the door in its closed position.

Exceptions:

1. A 39 inch (991 mm) length is acceptable when a minimum clear opening width of 34 inches (864 mm) is provided.
2. The floor or landing on the dwelling unit side of the primary entry door and any required exit door shall have a minimum length of not less than 44 inches (1118 mm). Section 1126A.3 shall apply to maneuvering clearances at the side of the door exposed to common or public use spaces.

1132A.5.2 Strike edge maneuvering space at doors. The width of the level area on the side to which the door swings shall extend 18 inches (457 mm) past the strike edge for all doors. The width of the level area at the exterior side of the primary entry door and any required exit doors shall comply with Section 1126A.

Notes:

1. See Section 1134A for bathrooms that are required to be accessible.
2. Twenty-four inches (610 mm) is preferred for strike edge clearance.

1132A.6 Closer-effort to operate doors. Maximum effort to operate doors shall not exceed $8\frac{1}{2}$ pounds (38 N) for exterior doors and 5 pounds (22 N) for interior doors, such pull or push effort being applied at right angles to hinged doors and at the center plane of sliding or folding doors. Compensating devices or automatic door operators may be utilized to meet these standards. When fire doors are required, the maximum effort to operate the door may be increased to the minimum allowable by the appropriate enforcement agency, not to exceed 15 pounds (66.7 N).

1132A.7 Type of lock or latch. The type of latch and lock required for all doors shall be in accordance with Chapter 10, Section 1003.3.1.8.

1132A.8 Hand-activated door hardware. Hand-activated door latching, locking and opening hardware shall be centered between 30 inches (762 mm) and 44 inches (1118 mm) above the floor. Latching and locking doors that are hand-activated and on an accessible route shall be operable with a single effort by lever-type hardware, panic bars, push-pull activating bars or other hardware designed to provide passage without requiring the ability to grasp the opening hardware. Locked exit doors shall operate consistent with Section 1132A.6, in the direction of egress.

1132A.8.1 Lever-type hardware. The lever or lever of actuated latches or locks shall be curved with a return to within $\frac{1}{2}$ inch (12.7 mm) of the door to prevent catching on the clothing of persons during egress in Group R and U occupancies with an occupant load greater than 10.

1132A.9 Smooth surface. The bottom 10 inches (254 mm) of all doors shall have a smooth, uninterrupted surface to allow the door to be opened by a wheelchair footrest without creating a trap or hazardous condition. Where narrow frame doors are used, a 10-inch-high (254 mm) smooth panel shall be installed on the push side of the door which will allow the door to be opened by a wheelchair footrest without creating a trap or hazardous condition. (See Figure 11A-8J).

Exception: Automatic and sliding doors.

1132A.10 Door signal devices. Every primary entrance to a covered multifamily dwelling unit shall be provided with a door buzzer, bell, chime or equivalent. The activating mechanism shall be mounted a maximum of 48 inches (1219 mm) above the floor and connected to permanent wiring.

SECTION 1133A KITCHENS

1133A.1 General. Kitchens shall be on an accessible route and shall comply with this section.

1133A.2 Clear floor space. Clear floor space at kitchens shall comply with the following:

1. A clear floor space at least 30-inches (762 mm) by 48-inches (1219 mm) that allows a parallel approach by a person in a wheelchair shall be provided at the range or cooktop.
2. A clear floor space at least 30 inches (762 mm) by 48 inches (1219 mm) that allows either a parallel or forward approach shall be provided at the kitchen sink and all other fixtures or appliances including the oven, dishwasher, refrigerator/freezer and trash compactor.
3. The centerline of the 30-inch (762 mm) by 48-inch (1219 mm) clear floor space provided for parallel or forward approach shall be aligned with the centerline of the appliance or fixture. (See Figure 11A-10A).

1133A.2.1 Clear width. Kitchens shall have a minimum clear width measured between any cabinet, countertop or the face of any appliance (excluding handles and controls) that projects into the kitchen and the opposing cabinet, countertop, appliance or wall as follows:

1. U-shaped kitchens, designed with parallel approach at a range or cooktop located at the base of the U, shall have a minimum clear width of at least 60 inches (1524 mm). (See Figure 11A-10A).
2. U-Shaped kitchens, designed with a cooktop or sink located at the base of the U which provides a 30-inch-wide (762 mm) knee space to a height of 27 inches (686 mm) above the floor to allow for a forward approach, shall have a clear width of at least 48 inches (1219 mm). (See Figure 11A-10A).
3. All other kitchen designs shall provide a minimum clear width of at least 48 inches (1219 mm). (See Figure 11A-10A).

1133A.3 Removable base cabinets. Base cabinets directly under the kitchen sink counter area, including toeboard and shelving, shall be removable without the use of specialized tools or specialized knowledge in order to provide clearance for a wheelchair. The finish floor beneath the kitchen sink counter area shall be extended to the wall.

1133A.4 Countertops. Kitchen countertops shall comply with this section and shall be provided with the following (see Section 1133A.4.1 for repositionable countertop requirements):

1. A minimum linear length of 30 inches (762 mm) of countertop shall be provided for the kitchen sink installation.
2. A minimum linear length of 30 inches (762 mm) of countertop shall be provided for a work surface.
3. The sink and work surface may be a single integral unit a minimum of 60 inches (1524 mm) in length, or be separate components.

Exception: Two 15-inch (381 mm) minimum width breadboards may be provided in lieu of the required 30 inches (762 mm) of countertop work surface.

1133A.4.1 Repositionable countertops. Repositionable countertops shall be provided in a minimum of 5 percent of the covered multifamily dwelling units. Repositionable countertops shall comply with the following:

1. The kitchen sink and work surface space required by Section 1133A.4 shall be designed to enable repositioning to a minimum height of 28 inches (711 mm).
2. Base cabinets directly under the kitchen sink and work surface shall be removable to provide clearance for a wheelchair.
3. The sides of adjacent cabinets and the back wall, which may become exposed to moisture or food handling when a countertop is lowered, shall be constructed of durable, nonabsorbent materials appropriate for such uses.
4. Finished flooring shall be extended to the wall beneath the sink and work surface.

Exception:

1. Stone, cultured stone and tiled countertops may be used without meeting the repositioning requirements.
2. Two 15-inch (381 mm) minimum width breadboards may be provided in lieu of the required 30 inches (762 mm) of countertop work surface.

1133A.5 Lower shelving. Lower shelving and/or drawer space shall be provided in the kitchen at a height of no more than 48 inches (1219 mm) above the floor.

1133A.6 Kitchen sink faucet controls. Faucet controls and operating mechanisms shall be operable with one hand and shall not require tight grasping, pinching or twisting of the wrist.

The force required to activate controls shall be no greater than 5 pound force (22.2N). Lever-operated, push-type and electronically controlled mechanisms are examples of acceptable designs. Self-closing valves are allowed if the faucet remains open for at least 10 seconds.

SECTION 1134A BATHING AND TOILET FACILITIES

1134A.1 General. All bathrooms, bathing and toilet facilities within covered multifamily dwelling units shall comply with this section.

1134A.2 Number of complying bathrooms. Bathrooms shall be designed to comply with one of the following options:

Option 1. All bathrooms within the dwelling unit shall be designed to comply with the following:

1. Toilet, bathing and shower facilities shall comply with Section 1134A.4.
2. Bathtubs shall comply with Section 1134A.5.
3. Showers shall comply with Section 1134A.6.
4. Water closets shall comply with Section 1134A.7.
5. Lavatories, vanities, mirrors and towel fixtures shall comply with Section 1134A.8.
6. Bathrooms shall be provided with an accessible route into and through the bathroom.
7. If a door is provided, it shall comply with the requirements of Section 1132A.5.
8. A minimum 18-inch (457 mm) clear maneuvering space shall be provided on the swing side of the door at the strike edge of the door.
9. Switches, outlets and controls shall comply with Section 1142A.
10. Reinforced walls to allow for the future installation of grab bars around the toilet, tub and shower shall comply with Sections 1134A.5 for bathtubs, 1134A.6 for showers and 1134A.7 for water closets. Grab bars shall comply with Section 1127A.4.

Option 2. Only one bathroom within the dwelling unit shall be designed to comply with the following:

1. Toilet, bathing and shower facilities shall comply with Section 1134A.4.
2. Bathtubs shall comply with Section 1134A.5.
3. Showers shall comply with Section 1134A.6.
4. Water closets shall comply with Section 1134A.7.
5. Lavatories, vanities, mirrors and towel fixtures shall comply with Section 1134A.8.

Where both a tub and shower are provided in the bathroom, at least one shall be made accessible. Additional requirements apply to dwelling units containing two or more bathrooms when a bathtub is provided as the accessible bathing fixture.

Where two or more bathrooms are provided within the same dwelling unit and a bathtub is installed to comply with Option 2, Item 6 in one bathroom and a shower stall is provided in a subsequent bathroom, both the bathtub selected to comply with Option 2, Item 6 and at least one shower stall within the dwelling unit shall meet all the applicable accessibility requirements provided in Section 1134A. (See Section 1134A.5 for bathtubs, or Section 1134A.6 for showers.)

7. When two or more lavatories are provided, at least one shall be made accessible and comply with Section 1134A.8.
8. Bathrooms shall be provided with an accessible route into and through the bathroom.

9. If a door is provided, it shall comply with the requirements of Section 1132A.5.
10. A minimum 18-inch (457 mm) clear maneuvering space shall be provided on the swing side of the door at the strike edge of the door.
11. Switches, outlets and controls shall comply with Section 1142A.
12. Reinforced walls to allow for the future installation of grab bars around the toilet, tub and shower shall comply with Sections 1134A.5 for bathtubs, 1134A.6 for showers and 1134A.7 for water closets. Grab bars shall comply with Section 1127A.4.

When Option 2 is used, all additional bathrooms must comply with Items 8 through 12 above.

1134A.3 Powder rooms. All powder rooms shall be designed to comply with Section 1134A.2, Option 2, Items 8 through 12.. When the powder room is the only toilet facility located on an accessible level, it shall comply with the Option 2 Items listed above, plus all additional requirements located in Sections 1134A.4, 1134A.7 and 1134A.8.

1134A.4 Sufficient maneuvering space. Bathing and toilet facilities required to be adaptable shall provide sufficient maneuvering space for a person using a wheelchair or other mobility aid to enter and close the door; use the fixtures, reopen the door and exit.

Where the door swings into the bathroom or powder room, there shall be a clear maneuvering space outside the swing of the door of at least 30 inches by 48 inches (762 mm by 1219 mm) within the room. The clear maneuvering space shall allow the user to position a wheelchair or other mobility aid clear of the path of the door as it is closed and to permit use of fixtures.

Doors may swing into the required clear space at any fixture when a clear maneuvering space is provided outside the swing arc of the door so it can be closed.

Maneuvering spaces may include any knee space or toe space available below bathroom fixtures.

1134A.5 Bathtubs. Bathtubs required to be accessible shall comply with this section.

1. **Floor Space.** There shall be a minimum clear floor space 48 inches parallel by 30 inches perpendicular (1219 mm by 762 mm) to the side of a bathtub or bathtub-shower combination (measured from the foot or drain end of the bathtub) to provide for the maneuvering of a wheelchair and transfer to and from the bathing facilities. The area under a lavatory may be included in the clear floor space provided the knee and toe space comply with Section 1134A.8. Cabinets under lavatories and toilets shall not encroach into the clear floor space.
2. **Reinforced Walls for Grab Bars.** A bathtub installed without surrounding walls shall provide reinforced areas for the installation of floor-mounted grab bars.

Where a bathtub is installed with surrounding walls, grab bar reinforcement shall be located on each end of the bathtub, 32 inches to 38 inches (813 mm to 965 mm) above the floor; extending a minimum of 24 inches (610 mm) from the front edge of the bathtub toward the back wall of the bathtub. The grab bar

reinforcement shall be a minimum of 6 inches (152.4 mm) nominal in height. (See Figure 11A-9G).

Grab bar reinforcement shall be installed on the back wall of the bathtub a maximum of 6 inches (152.4 mm) above the bathtub rim extending upward to at least 38 inches (965 mm) above the floor. Grab bar backing shall be installed horizontally to permit the installation of a 48-inch (1219 mm) grab bar with each end a maximum of 6 inches (152.4 mm) from the end walls of the bathtub. The grab bar reinforcement shall be a minimum of 6 inches (152.4 mm) nominal in height.

3. **Bathtub Controls.** Faucet controls and operation mechanisms shall be operable with one hand and shall not require tight grasping, pinching or twisting of the wrist.

The force required to activate controls shall be no greater than 5 pound-force (22.2 N). Lever operated, push type and electronically controlled mechanisms are examples of acceptable designs.

4. **Shower Unit.** A shower spray unit is not required in bathtubs.

5. **Bathtub Enclosures.** Doors and panels of bathtub enclosures shall be substantially constructed from approved, shatter-resistant materials. Hinged doors shall open outward. Glazing used in doors and panels of bathtub enclosures shall be fully tempered, laminated safety glass or approved plastic. When glass is used, it shall have minimum thickness of not less than $\frac{1}{8}$ inch (3.17 mm) when fully tempered, or $\frac{1}{4}$ inch (6.35 mm) when laminated, and shall pass the test requirements of this part, Chapter 24, Glass and Glazing. Plastics used in doors and panels of bathtub enclosures shall be of a shatter-resistant type.

1134A.6 Showers. Showers required to be accessible shall comply with this section.

1. **Size.** When one or more shower stalls are provided within the same dwelling units, at least one shower stall shall comply with one of the following requirements.
 - 1.1 The shower stall shall measure at least 42 inches wide by 48 inches deep (1067 mm by 1219 mm) with an entrance opening of at least 36 inches (914 mm); or
 - 1.2 The shower stall shall measure at least 30 inches deep by 60 inches wide (762 mm by 1524 mm) with an entrance opening of at least 60 inches (1524 mm). A water closet may project a maximum of 12 inches (305 mm) into the opening, provided that a minimum of 36 inches (914 mm) clear space is maintained between the water closet and the shower wall as illustrated in Figure 11A-9L or;
 - 1.3 Other shower stall configurations shall measure at least 36 inches deep by 60 inches wide (914 mm by 1524 mm) with an entrance opening of at least 36 inches (914 mm) when a wall is installed on the opening side.

2. **Slope.** The maximum slope of the shower floor shall be $\frac{1}{2}$ inch (12.7 mm) per foot in any direction and shall slope to a drain located within 6 inches (152.4 mm) of the rear wall. The floor surfaces shall be of Carborundum or grit-faced tile or of material providing equivalent slip resistance.

3. **Floor Space.** A clear maneuvering space at least 30 inches in width by 48 inches in length (762 mm by 1219 mm) shall be located outside the shower, flush and parallel to the control wall.

4. **Reinforced Walls for Grab Bars.** Grab bar reinforcement shall be installed continuous in the walls of showers 32 inches to 38 inches (813 mm to 965 mm) above the floor. The grab bar reinforcement shall be a minimum of 6 inches (152.4 mm) nominal in height.

Glass-walled shower stalls shall provide reinforcement for installation of floor-mounted or ceiling-mounted grab bars.

5. **Thresholds.** When a threshold is used, it shall be a maximum of 2 inches (50.8 mm) in height and have a beveled or sloped angle not exceeding 1 unit vertical in 2 units horizontal.

6. **Shower Controls.** Faucet controls and operation mechanisms shall be operable with one hand and shall not require tight grasping, pinching or twisting of the wrist. The force required to activate controls shall be no greater than 5 pound-force (22.2N). Lever operated, push-type and electronically controlled mechanisms are examples of acceptable designs.

7. **Shower Enclosures.** Doors and panels of shower enclosures shall be substantially constructed from approved, shatter-resistant materials. Hinged shower doors shall open outward. Glazing used in doors and panels of shower enclosures shall be fully tempered, laminated safety glass or approved plastic. When glass is used, it shall have minimum thickness of not less than $\frac{1}{8}$ inch (3.17 mm) when fully tempered, or $\frac{1}{4}$ inch (6.35 mm) when laminated, and shall pass the test requirements of this part, Chapter 24, Glass and Glazing. Plastics used in doors and panels of showers enclosures shall be of a shatter-resistant type.

1134A.7 Water closets. Water closets in bathrooms or powder rooms required to be accessible shall comply with this section.

1. **Floor Space.** The minimum floor space provided at a water closet shall be 48 inches (1219 mm) in clear width. The clear floor space shall extend past the front edge of the water closet at least 36 inches (914 mm). See Figure 11A-9M.

Exception: The 48-inch (1219 mm) minimum clear width may be reduced to 36 inches (914 mm) for lavatories, cabinets, wing walls or privacy walls located immediately adjacent to a water closet which extend no more than 24 inches (610 mm) in depth.

Water closets shall be located within bathrooms in a manner that permits a grab bar to be installed on one side of the fixture. In locations where water closets are adjacent to

walls, vanities, lavatories or bathtubs, the centerline of the fixture shall be a minimum of 18 inches (457 mm) from the obstacle.

2. **Reinforced Walls for Grab Bars.** Where the water closet is not placed adjacent to a side wall, the bathroom shall have provisions for installation of floor-mounted, foldaway or similar alternative grab bars.

Where the water closet is placed adjacent to a side wall, reinforcement shall be installed on both sides or one side and the back. If reinforcement is installed at the back, it shall be installed between 32 inches (813 mm) and 38 inches (965 mm) above the floor. The grab bar reinforcement shall be a minimum of 6 inches (152.4 mm) nominal in height. The backing shall be a minimum of 40 inches (1016 mm) in length.

Reinforcement installed at the side of the water closet shall be installed 32 inches to 38 inches (813 mm to 965 mm) above the floor. The reinforcement shall be installed a maximum of 12 inches (305 mm) from the rear wall and shall extend a minimum of 26 inches (660 mm) in front of the water closet. The grab bar reinforcement shall be a minimum of 6 inches (152.4 mm) nominal in height.

3. **Seat Height.** The minimum height of water closet seats shall be 15 inches (381 mm) above the floor.

4. **Water Closet Controls.** Water closet controls shall be mounted no more than 44 inches (1118 mm) above the floor. The force required to activate controls shall be no greater than 5 pound-force (22.2 N).

1134A.8 Lavatories, vanities, mirrors and towel fixtures. Bathrooms or powder rooms required to be accessible shall have at least one accessible lavatory. Where mirrors and towel fixtures are provided, at least one of each shall be accessible.

1. **Location.** Vanities and lavatories shall be installed with the centerline of the fixture a minimum of 18 inches (457 mm) horizontally from an adjoining wall or fixture to allow for forward approach. When parallel approach is provided, lavatories shall be installed with the centerline of the fixture a minimum of 24 inches (610 mm) horizontally from an adjoining wall or fixture. The top of the fixture rim shall be a maximum of 34 inches (864 mm) above the finished floor.

2. **Floor Space.** A clear maneuvering space at least 30 inches by 48 inches (762 mm by 1219 mm) shall be provided at lavatories and shall be centered on the lavatory.

3. **Cabinets.** Cabinets under lavatories are acceptable-provided the bathroom has space to allow a parallel approach by a person in a wheelchair and the lavatory cabinets are designed with adaptable knee and toe space.

4. **Knee and toe space.** Knee and toe space shall be provided as follows:

4.1. The knee space shall be at least 30 inches (762 mm) wide and 8 inches (203.2 mm) deep.

4.2. The knee space shall be at least 29 inches (737 mm) high at the front face and reducing to not less than 27 inches (686 mm) at a point 8 inches (203.2 mm) back from the front edge.

4.3. The knee and toe space required in this section shall be provided by one of the following:

- 4.3.1. The space beneath the lavatory shall be left clear and unobstructed;
- 4.3.2. Any cabinet beneath the lavatory shall be removable without the use of specialized knowledge or specialized tools; or
- 4.3.3. Doors to the cabinet beneath the lavatory shall be removable or openable to provide the required unobstructed knee and toe space.

4.4. The toe space required in this section shall be provided as follows:

- 4.4.1. Shall be at least 30 inches (762 mm) wide and centered on the lavatory.
- 4.4.2. Shall be at least 17 inches (432 mm) deep, measured from the front edge.
- 4.4.3. Shall be at least 9 inches (228.6 mm) high from the floor.

5. **Finished Floor** The finished floor beneath the lavatory shall be extended to the wall.

6. **Plumbing Protection.** Hot water and drain pipes exposed under lavatories shall be insulated or otherwise covered. There shall be no sharp or abrasive surfaces under lavatories.

7. **Lavatory Faucet Controls.** Faucet controls and operation mechanisms shall be operable with one hand and shall not require tight grasping, pinching or twisting of the wrist.

The force required to activate controls shall be no greater than 5 pound-force (22.2 N). Lever operated, push-type and electronically controlled mechanisms are examples of acceptable designs. Self-closing valves are allowed if the faucet remains open for at least 10 seconds.

8. **Mirrors and Towel Fixtures.** Where mirrors or towel fixtures are provided they shall be mounted with the bottom edge no higher than 40 inches (1016 mm) from the floor.

SECTION 1135A LAUNDRY ROOMS

1135A.1 General. If clothes washing machines and clothes dryers are provided in covered multifamily dwelling units, one of each type of appliance shall be provided. Where front-loading clothes washers are not provided, management shall provide assistive devices, on request of the occupant, to permit the use of top-loading clothes washers.

SECTION 1136A ELECTRICAL RECEPTACLE, SWITCH AND CONTROL HEIGHTS

1136A.1 Receptacle heights. Electrical receptacle outlets on branch circuits of 30 amperes or less and communication sys-

tem receptacles shall be located no more than 48 inches (1219 mm) measured from the top of the receptacle outlet box or receptacle housing nor less than 15 inches (381 mm) measured from the bottom of the receptacle outlet box or receptacle housing to the level of the finished floor or working platform. If the reach is over an obstruction (for example, a kitchen base cabinet) between 20 and 25 inches (508 and 635 mm) in depth, the maximum height measured at the box is reduced to 44 inches (1118 mm) for forward approach, or 46 inches (1168 mm) for side approach, provided the obstruction is no more than 24 inches (610 mm) in depth. Obstructions shall not extend more than 25 inches (635 mm) from the wall beneath the receptacle.

Outlets that do not satisfy these specifications are acceptable, provided that comparable outlets, that perform the same functions, are provided within the same area and are accessible.

Exceptions:

1. Receptacle outlets installed as part of permanently installed baseboard heaters are exempt.
2. Required receptacle outlets shall be permitted in floors when adjacent to sliding panels or walls.
3. Baseboard electrical outlets used in relocatable partitions, window walls or other electrical convenience floor outlets are not subject to the minimum height requirements.
4. This section shall not apply to existing buildings when the enforcing agency determines that compliance with these standards would create an unreasonable hardship.

Note: The intent of the measurement is to ensure that receptacles fall within the reach range of 15 inches to 48 inches (381 to 1219 mm).

1136A.2 Switch and control heights. Controls or switches intended to be used by the occupant of the room or area to control lighting and receptacle outlets, appliances, alarms or cooling, heating and ventilating equipment shall be located no more than 48 inches (1219 mm) measured from the top of the outlet box nor less than 15 inches (381 mm) measured from the bottom of the outlet box to the level of the finished floor or working platform. If the reach is over a physical barrier or an obstruction (for example, a kitchen base cabinet) between 20 and 25 inches (508 and 635 mm) in depth, the maximum height is reduced to 44 inches (1118 mm) for forward approach, or 46 inches (1168 mm) for side approach, provided the obstruction is no more than 24 inches (610 mm) in depth. Physical barriers or obstructions shall not extend more than 25 inches (635 mm) from the wall beneath a control.

Controls that do not satisfy these specifications are acceptable-provided that comparable controls or outlets, that perform the same functions, are provided within the same area and are accessible.

Exception: Appliances (e.g. kitchen stoves, dishwashers, range hoods, microwave ovens and similar appliances) which have controls located on the appliance.

6. Be capable of lowering the operator at least 18 inches (457 mm) below the surface of the water.

SECTION 1142A ELECTRICAL RECEPTACLE, SWITCH AND CONTROL HEIGHTS

1142A.1 Receptacle heights. Electrical receptacle outlets on branch circuits of 30 amperes or less and communication system receptacles shall be located no more than 48 inches (1219 mm) measured from the top of the receptacle outlet box or receptacle housing nor less than 15 inches (381 mm) measured from the bottom of the receptacle outlet box or receptacle housing to the level of the finished floor or working platform. If the reach is over an obstruction (for example, a kitchen base cabinet) between 20 and 25 inches (508 and 635 mm) in depth, the maximum height measured at the box is reduced to 44 inches (1118 mm) for forward approach, or 46 inches (1168 mm) for side approach, provided the obstruction is no more than 24 inches (610 mm) in depth. Obstructions shall not extend more than 25 inches (635 mm) from the wall beneath the receptacle.

Outlets that do not satisfy these specifications are acceptable provided that comparable outlets, that perform the same functions, are provided within the same area and are accessible.

Exceptions:

1. Receptacle outlets installed as part of permanently installed baseboard heaters are exempt.
2. Required receptacle outlets shall be permitted in floors when adjacent to sliding panels or walls.
3. Baseboard electrical outlets used in relocatable partitions, window walls or other electrical convenience floor outlets are not subject to the minimum height requirements.
4. This section shall not apply to existing buildings when the enforcing agency determines that compliance with these standards would create an unreasonable hardship.

Note: The intent of the measurement is to ensure that receptacles fall within the reach range of 15 inches to 48 inches.

1142A.2 Switch and control heights. Controls or switches intended to be used by the occupant of the room or area to control lighting and receptacle outlets, appliances, alarms or cooling, heating and ventilating equipment shall be located no more than 48 inches (1219 mm) measured from the top of the outlet box nor less than 15 inches (381 mm) measured from the bottom of the outlet box to the level of the finished floor or working platform. If the reach is over a physical barrier or an obstruction (for example, a kitchen base cabinet) between 20 and 25 inches (508 and 635 mm) in depth, the maximum height is reduced to 44 inches (1118 mm) for forward approach, or 46 inches (1168 mm) for side approach, provided the obstruction is no more than 24 inches (610 mm) in depth. Physical barriers or obstructions shall not extend more than 25 inches (635 mm) from the wall beneath a control.

Controls that do not satisfy these specifications are acceptable provided that comparable controls or outlets, that perform

the same functions, are provided within the same area and are accessible.

SECTION 1143A SIGNAGE

1143A.1 General. When signs and/or identification devices are provided they shall comply with this section.

Exception: Signs need not be provided within dwelling units.

1143A.2 Identification signs. When signs identify permanent rooms and spaces of a building or site, they shall comply with Sections 1143A.5, 1143A.6, 1143A.8, 1143A.9 and 1143A.10.

Note: See Section 1124A for additional signage requirements applicable to elevators and Section 1127A.7 for sanitary facilities.

1143A.3 Direction and informational signs. When signs direct to or give information about permanent rooms and spaces of a building or site, they shall comply with Sections 1143A.5, 1143A.6 and 1143A.7.

1143A.4 Accessibility signs. When signs identify, direct or give information about accessible elements and features of a building or site, they shall include the appropriate symbol of accessibility and shall comply with Section 1143A.5 and, when applicable, Section 1143A.10.

1143A.5 Finish and contrast. Characters, symbols and their background shall have a non glare finish. Characters and symbols shall contrast with their background, either light on a dark background or dark on a light background.

1143A.6 Proportions. Characters on signs shall have a width-to-height ratio of between 3:5 and 1:1 and a stroke width-to-height ratio of between 1:5 and 1:10.

1143A.7 Character height. Characters and numbers on signs shall be sized according to the viewing distance from which they are to be read. The minimum height is measured using an uppercase "X." Lowercase characters are permitted. For signs suspended or projected above the finish floor greater than 80 inches (2032 mm), the minimum character height shall be 3 inches (76 mm).

1143A.8 Raised characters and pictorial symbol signs. When raised characters are required or when pictorial symbols (pictograms) are used on such signs, they shall conform to the following requirements:

1. **Character Type.** Characters on signs shall be raised $\frac{1}{32}$ -inch (0.794 mm) minimum and shall be sans serif uppercase characters accompanied by Grade 2 Braille complying with Section 1143A.9.
2. **Character Size.** Raised characters shall be a minimum of $\frac{5}{8}$ inch (15.9 mm) and a maximum of 2 inches (51 mm) high.
3. **Pictorial Symbol Signs (Pictograms).** Pictorial symbol signs (pictograms) shall be accompanied by the verbal description placed directly below the pictogram. The

outside dimension of the pictogram field shall be a minimum of 6 inches (152 mm) in height.

4. **Character Placement.** Characters and Braille shall be in a horizontal format. Braille shall be placed a minimum of $\frac{3}{8}$ inch (9.5 mm) and a maximum of $\frac{1}{2}$ inch (12.7 mm) directly below the tactile characters, flush left or centered. When tactile text is multilined, all Braille shall be placed together below all lines of tactile text.

1143A.9 Braille. Contracted Grade 2 Braille shall be used wherever Braille is required in other portions of these standards. Dots shall be $\frac{1}{10}$ inch (2.54 mm) on center in each cell with $\frac{2}{10}$ -inch (5.08 mm) space between cells, measured from the second column of dots in the first cell to the first column of dots in the second cell. Dots shall be raised a minimum of $\frac{1}{40}$ inch (0.635 mm) above the background. Braille dots shall be domed or rounded.

1143A.10 Mounting location and height. Where permanent identification signs are provided for rooms and spaces, signs shall be installed on the wall adjacent to the latch side of the door. Where there is no wall space on the latch side, including at double leaf doors, signs shall be placed on the nearest adjacent wall, preferably on the right.

Where permanent identification signage is provided for rooms and spaces, it shall be located on the approach side of the door as one enters the room or space. Signs that identify exits shall be located on the same side of the door as the visual exit sign.

Mounting height shall be 60 inches (1524 mm) above the finish floor to the centerline of the sign. Mounting location shall be determined so that a person may approach within 3 inches (76 mm) of the signage without encountering protruding objects or standing within the swing of a door.

Note: See also Section 1127A.7 for additional signage requirements applicable to sanitary facilities.

**SECTION 1144A
Reserved**

**SECTION 1145A
Reserved**

**SECTION 1146A
Reserved**

**SECTION 1147A
Reserved**

**SECTION 1148A
Reserved**

**SECTION 1149A
Reserved**

Division VI—SITE IMPRACTICALITY TESTS

Division VI Table of Contents

Section 1150A Site Impracticality Tests

Test No. 1—Individual Building Test

Test No. 2—Site Analysis Test

Test No. 3—Unusual Characteristics Test

**SECTION 1150A
SITE IMPRACTICALITY TESTS**

1150A.1 General. Covered multifamily dwellings in buildings without an elevator, located on sites with difficult terrain conditions or unusual characteristics, may employ the site impracticality tests in this division for determining the accessibility and adaptability provisions required by this chapter.

Except as provided for in Section 1102A.3.1, the provisions of this section do not apply to multistory dwelling units in nonelevator buildings.



SINGLE BUILDING WITH ONE COMMON (LOBBY) ENTRANCE

The following may only be used for determining required access to covered multifamily dwelling units, in a single building with one common (lobby) entrance, located on a site with difficult terrain conditions or unusual characteristics:

All ground-floor units in nonelevator buildings shall be adaptable and on an accessible route unless an accessible route to the common (lobby) entrance is not required as determined by Test No. 1, Individual Building Test, or Test No. 3, Unusual Characteristics Test, as described in this section.

Sites where either Test No. 1 or Test No. 3 is used and it is determined that an accessible route to the common (lobby) entrance is not required, at least 20 percent of the ground floor dwelling units shall comply with Division IV, and all remaining ground floor dwelling units shall comply with the features listed in Section 1150A.2 unless exempted by Test No. 3, Unusual Characteristics Test.

Test No. 1—Individual Building Test may only be used if the site has terrain over 15 percent slope.

Test No. 3—Unusual Characteristics Test may be used if applicable.

Provisions to Test Nos. 1 and 2. Where a building elevator is provided only as means of creating an accessible route to covered multifamily dwelling units on a ground floor, the building is not considered to be an elevator building for purposes of this code; hence, only the ground floor dwelling units would be covered.

TEST NO. 1—INDIVIDUAL BUILDING TEST

It is not required by this code to provide an accessible route when the terrain of the site is such that both of the following apply:

1. The slopes of the undisturbed site measured between the planned entrance and all vehicular or pedestrian

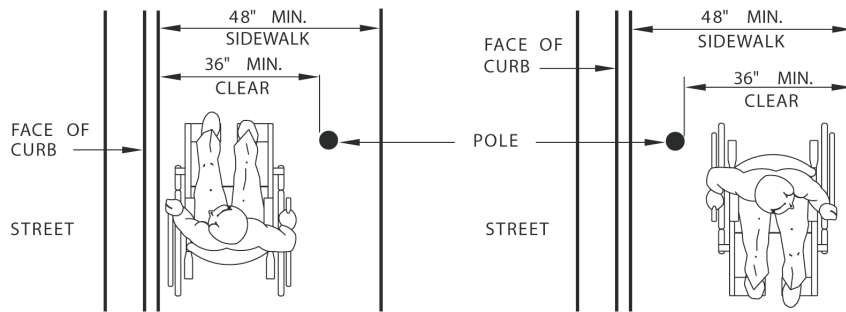

(a) SIDEWALK OBSTRUCTIONS

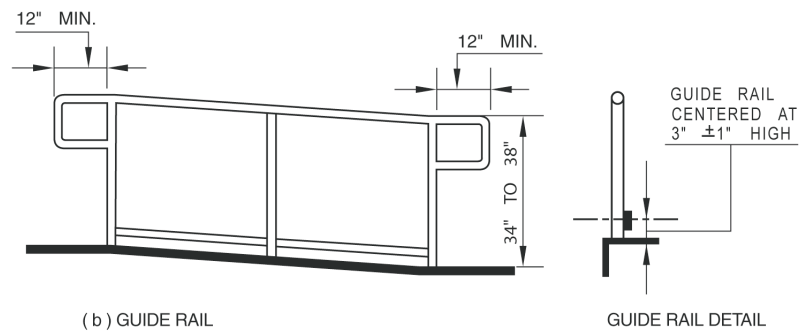

(b) GUIDE RAIL

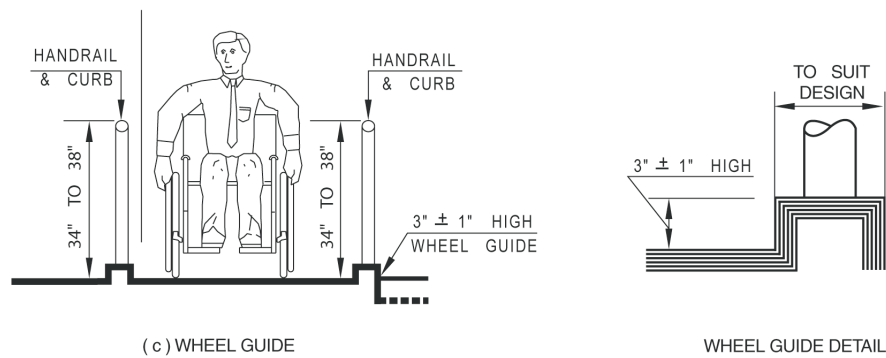

(c) WHEEL GUIDE

THESE DIAGRAMS ILLUSTRATE THE SPECIFIC REQUIREMENTS OF THESE REGULATIONS AND ARE INTENDED ONLY AS AN AID FOR BUILDING DESIGN AND CONSTRUCTION.

FIGURE 11A-5A—RAMPS AND SIDEWALKS

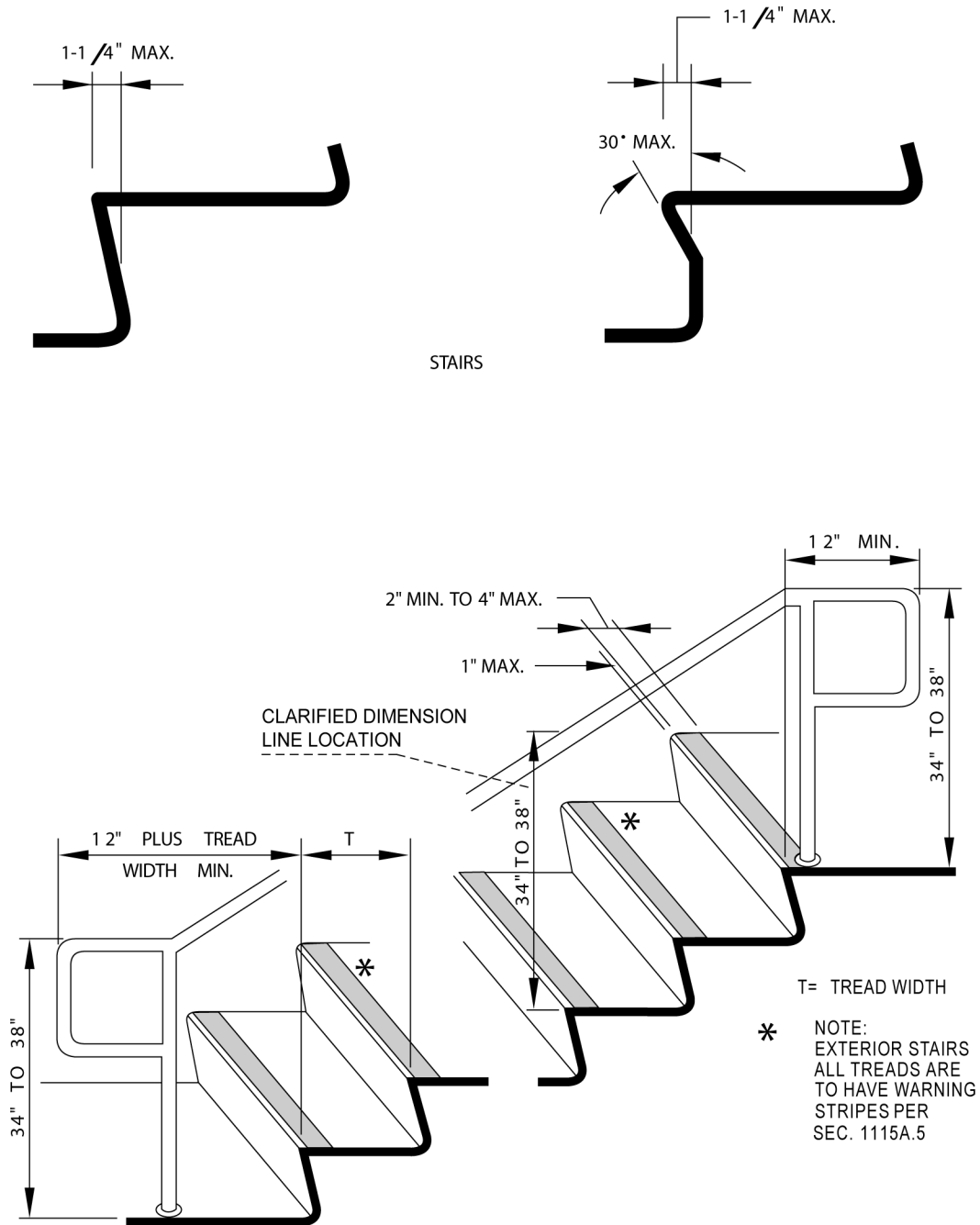

THESE DIAGRAMS ILLUSTRATE THE SPECIFIC REQUIREMENTS OF THESE REGULATIONS AND ARE INTENDED ONLY AS AN AID FOR BUILDING DESIGN AND CONSTRUCTION.

FIGURE 11A-6A—WARNING STRIPING AND HANDRAIL EXTENSIONS

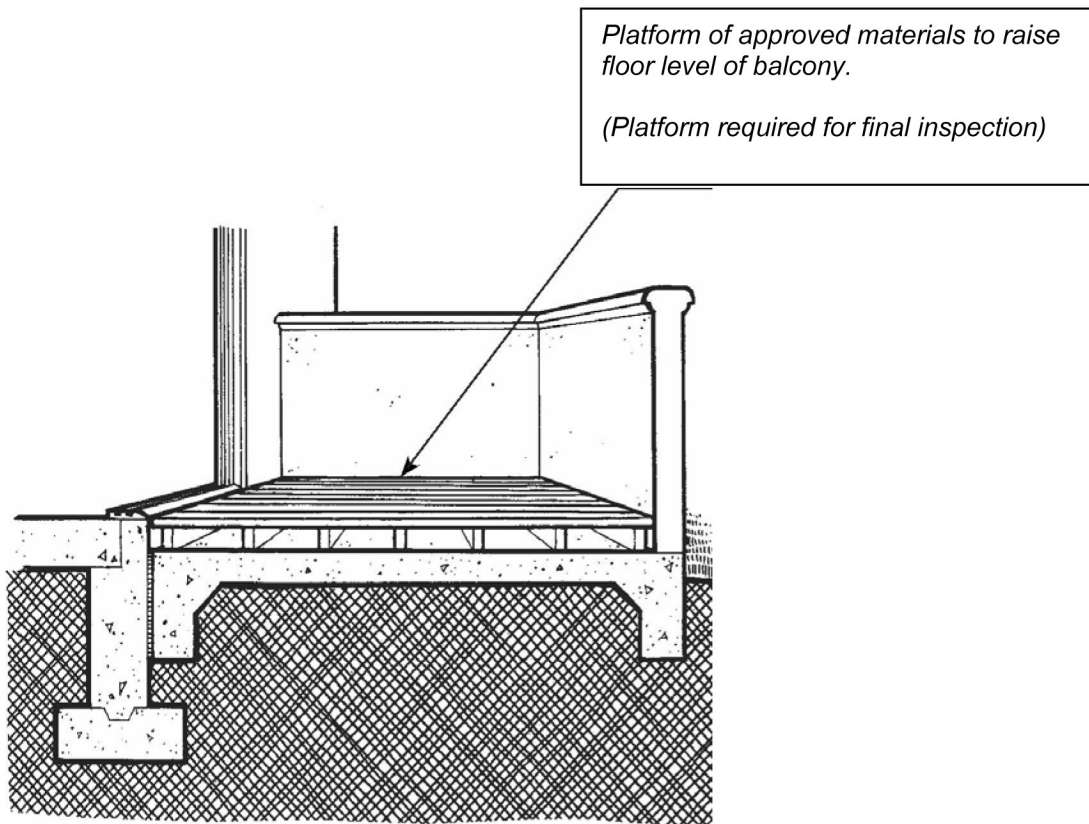

FIGURE 11A-8J—PLATFORM AT SECONDARY EXTERIOR DOOR

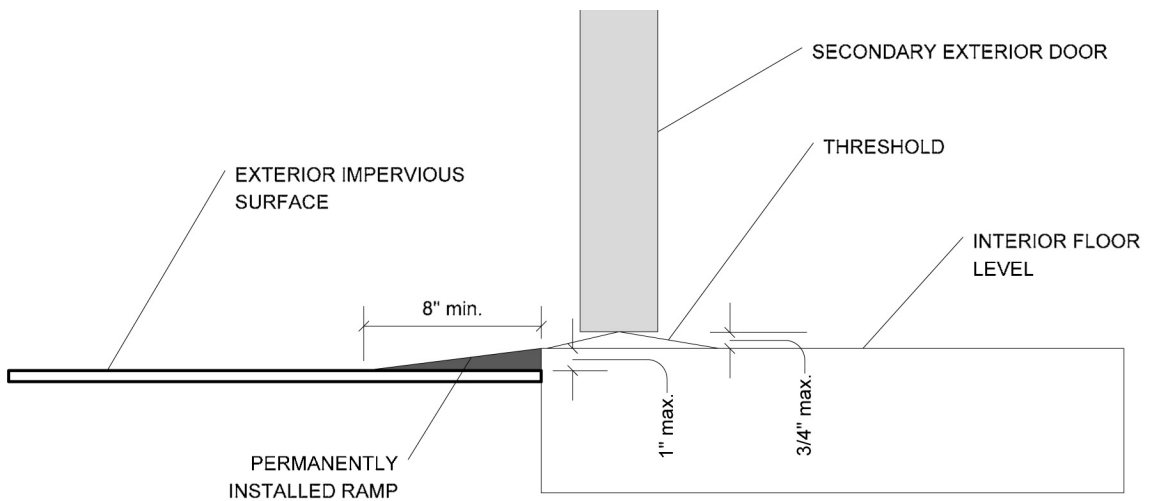
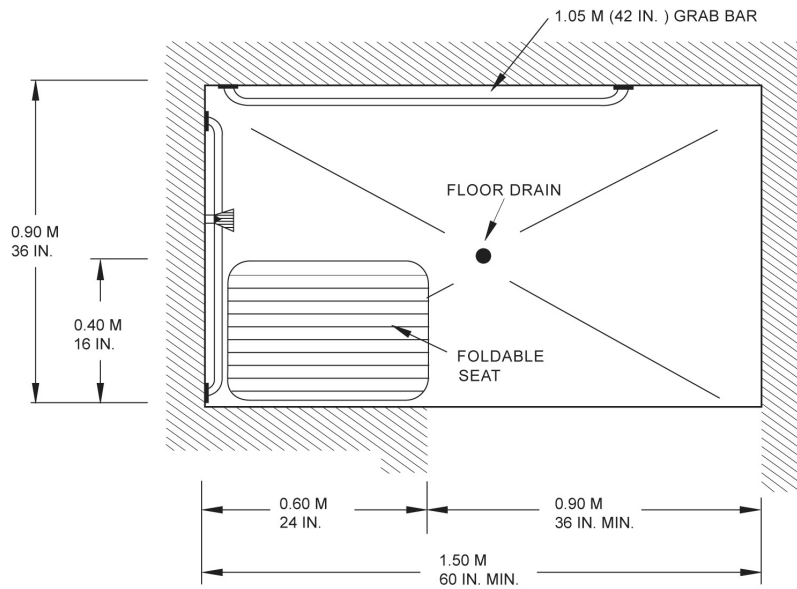

FIGURE 11A-8K—RAMP AT SECONDARY EXTERIOR DOOR



THIS DIAGRAM ILLUSTRATES THE SPECIFIC REQUIREMENTS OF THESE REGULATIONS AND IS INTENDED ONLY AS AN AID FOR BUILDING DESIGN AND CONSTRUCTION.

FIGURE 11A-9K—ALTERNATIVE ROLL-IN

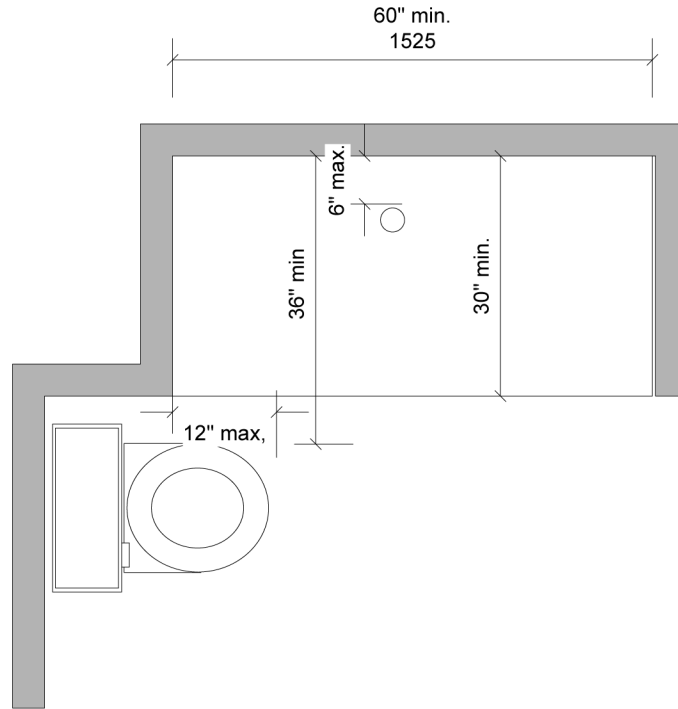

FIGURE 11A-9L—SHOWER WITH WATER CLOSET

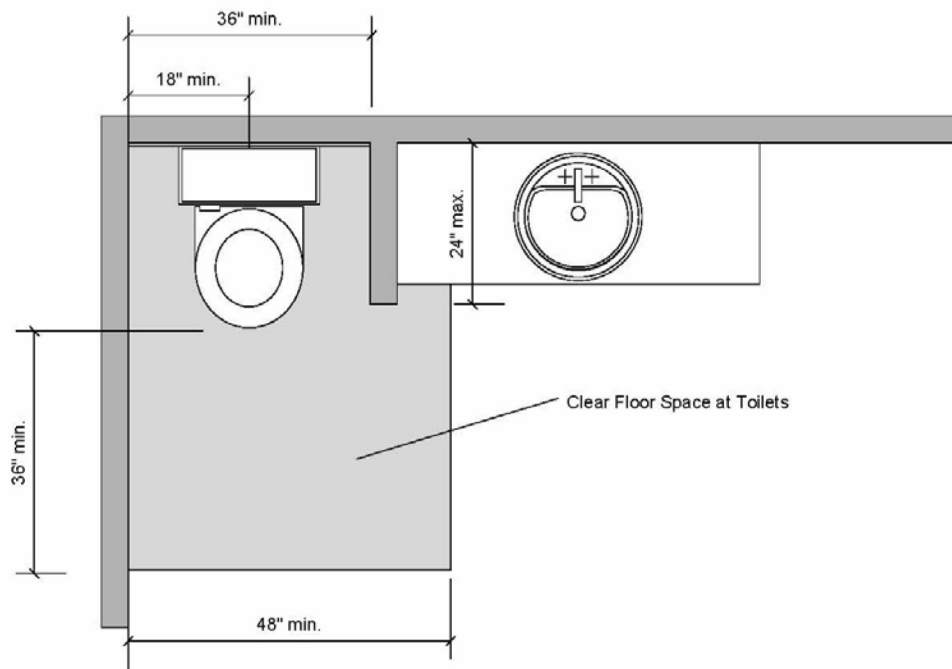
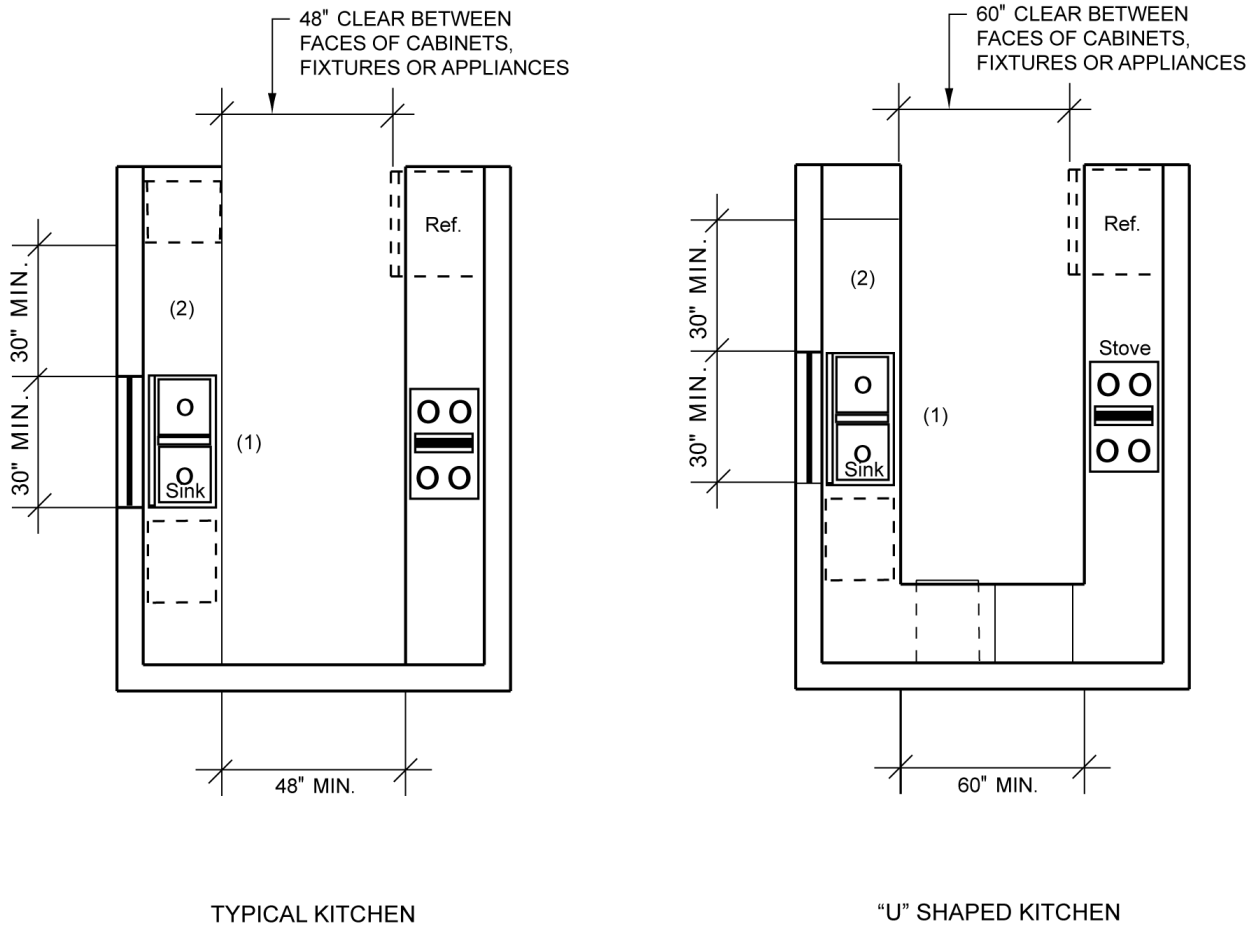
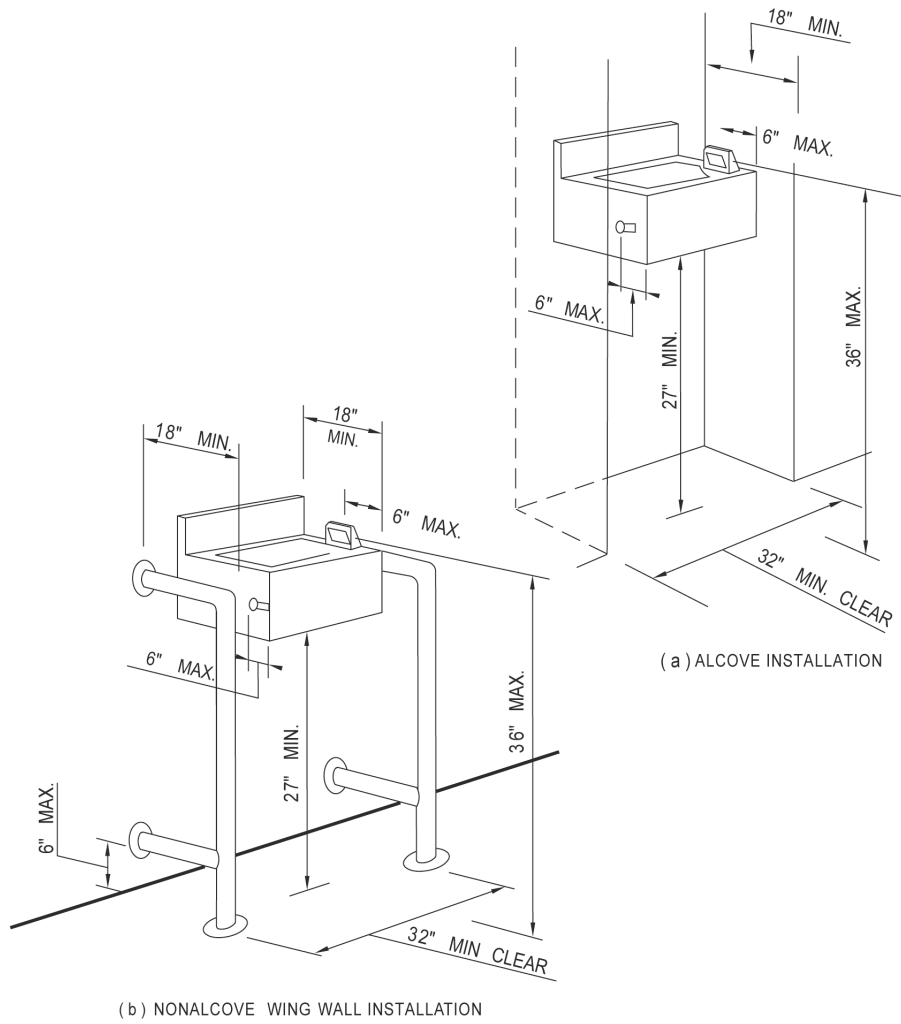

FIGURE 11A-9M—WING WALL OR CABINET AT WATER CLOSET



- (1) 30-inch wide counter top space for sink installation with removable base cabinet and finish flooring beneath sink
- (2) 30-inch wide counter top workspace
- (3) 30-inch by 48-inch clear space adjacent to range or cooktop to allow parallel approach
- (4) 30-inch by 48-inch either parallel approach at oven, dishwasher, trash compactor or refrigerator

FIGURE 11A-10A—KITCHEN SPECIFICATIONS



THESE DIAGRAMS ILLUSTRATE THE SPECIFIC REQUIREMENTS OF THESE REGULATIONS AND ARE INTENDED ONLY AS AN AID FOR BUILDING DESIGN AND CONSTRUCTION

FIGURE 11A-11A—WATER FOUNTAINS

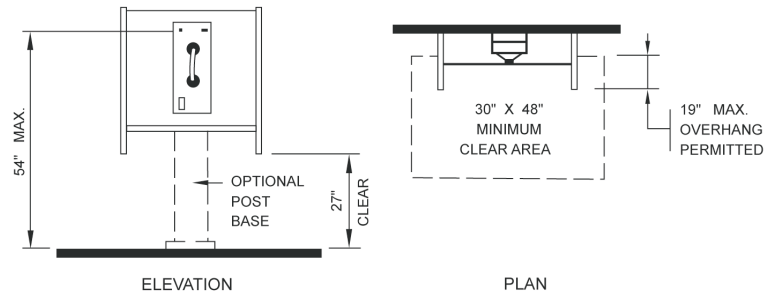

(a) SIDE REACH ARRANGEMENT

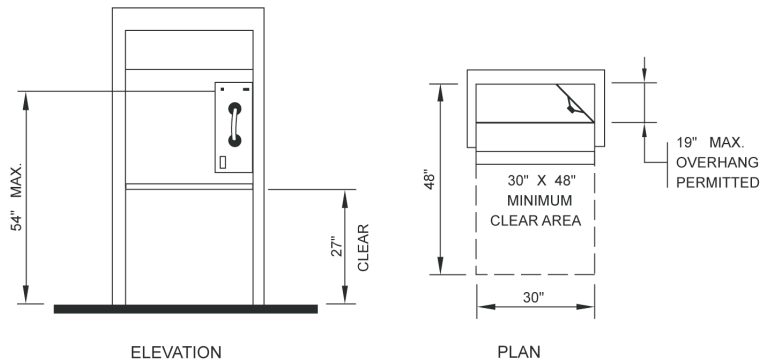

(b) FULL HEIGHT ENCLOSURE

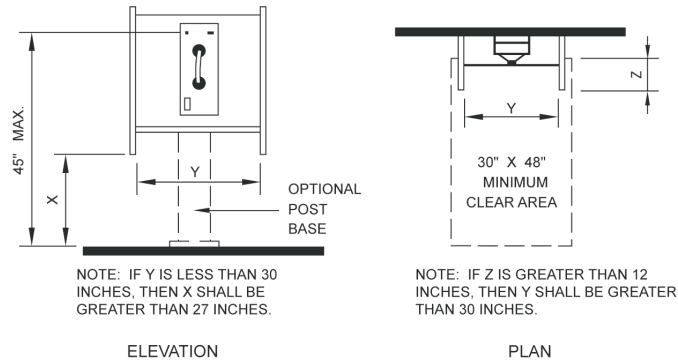

(c) FORWARD REACH ARRANGEMENT

THESE DIAGRAMS ILLUSTRATE THE SPECIFIC REQUIREMENTS OF THESE REGULATIONS AND ARE INTENDED ONLY AS AN AID FOR BUILDING DESIGN AND CONSTRUCTION

FIGURE 11A-11B—MOUNTING HEIGHTS AND CLEARANCES FOR TELEPHONES

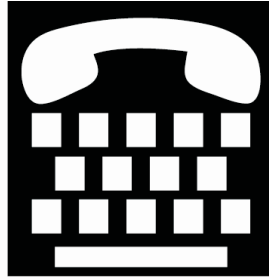

FIGURE 11A-11C—INTERNATIONAL TTY SYMBOL

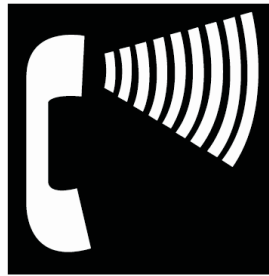

FIGURE 11A-11D—VOLUME CONTROL TELEPHONES



FIGURE 11A-11E—INTERNATIONAL SYMBOL OF ACCESS FOR HEARING LOSS

THESE DIAGRAMS ILLUSTRATE THE SPECIFIC REQUIREMENTS OF THESE REGULATIONS AND ARE INTENDED ONLY AS AN AID FOR BUILDING DESIGN AND CONSTRUCTION.

CHAPTER 11B

ACCESSIBILITY TO PUBLIC BUILDINGS, PUBLIC ACCOMMODATIONS, COMMERCIAL BUILDINGS AND PUBLICLY FUNDED HOUSING

Note: For housing accessibility, see Chapter 11A.

Division I—NEW BUILDINGS

SECTION 1101B SCOPE

See Chapter 1, Section 109.1.

1101B.1 General. Buildings or portions of buildings shall be accessible to persons with disabilities as required by this chapter.

1101B.2 Design. The design and construction of accessible building elements shall be in accordance with this chapter and Section 1114B.1.1.

1101B.3 Maintenance of accessible features.

1. A public accommodation shall maintain in operable working condition those features of facilities and equipment that are required to be accessible to and usable by persons with disabilities.
2. This section does not prohibit isolated or temporary interruptions in service or access due to maintenance or repairs.

1101B.4 Dimension conventions. Dimensions that are not stated as “maximum” or “minimum” are absolute.

1101B.5 Construction and manufacturing tolerances. All dimensions are subject to conventional industry tolerances except where the requirement is stated as a range with specific minimum and maximum end points.

1101B.6 Commercial facilities located in private residences.

1. When a commercial facility is located in a private residence, the portion of the residence used exclusively as a residence is not covered by this chapter, except as required by Section 1111B.5, but that portion used both for the commercial facility and for residential purposes is covered by the new construction and alteration requirements of this code.
2. The portion of the residence covered extends to those elements used to enter the commercial facility, including the homeowner’s front sidewalk, if any, the door or entryway, and hallways; and those portions of the residence, interior or exterior, available to or used by employees or visitors of the commercial facility, including sanitary facilities.

SECTION 1102B DEFINITIONS

For additional definitions pertinent to the Division of the State Architect—Access Compliance accessibility requirements, see Chapter 2, Section 202.

For the purpose of the chapter, certain terms are defined as follows:

ACCESS AISLE is an accessible pedestrian space adjacent to or between parking spaces that provides clearances in conformance with this chapter.

ACCESSIBILITY is the combination of various elements in a building, facility, site, or area, or portion thereof which allows access, circulation and the full use of the building and facilities by persons with disabilities in conformance with this chapter.

ACCESSIBLE is approachable and usable by persons with disabilities in compliance with this code.

ACCESSIBLE ELEMENT is an element specified by the regulations adopted by the Division of the State Architect—Access Compliance.

ACCESSIBLE MEANS OF EGRESS. See Section 1002.1.

ACCESSIBLE ROUTE OF TRAVEL is a continuous unobstructed path connecting all accessible elements and spaces in an accessible building or facility that can be negotiated by a person with a disability using a wheelchair and that is also safe for and usable by persons with other disabilities, and that is consistent with the definition of “Path of travel” in this section. Interior accessible routes may include corridors, floors, ramps, elevators, lifts and clear floor space at fixtures. Exterior accessible routes may include parking access aisles, curb ramps, crosswalks at vehicular ways, walks, sidewalks, ramps, and lifts. An accessible route does not include stairs, steps, or escalators.

ACCESSIBLE SPACE is a space that complies with the regulations adopted by the Division of the State Architect—Access Compliance.

ADAPTABILITY is the capability of spaces or facilities to be readily modified and made accessible.

ADMINISTRATIVE AUTHORITY is a governmental agency that adopts or enforces regulations and guidelines for the design, construction, or alteration of buildings and facilities.

AISLE is a circulation path between objects such as seats, tables, merchandise, equipment, displays, shelves, desks, etc., that provides clearances in conformance with this chapter.

AISLE, EMPLOYEE AREAS (as required for architectural accessibility) is a space that serves as a passageway, which is

created by architectural components such as walls, fixed cabinetry or fixtures and not moveable components such as furniture.

AREA OF REFUGE. See Section 1002.1.

ASSEMBLY AREA is a room or space accommodating a group of individuals for recreational, educational, political, social or amusement purposes, or for the consumption of food and drink.

AUTOMATIC DOOR is a door equipped with a power operated mechanism and controls that open and close the door automatically upon receipt of a momentary actuating signal. The switch that begins the automatic cycle may be a photoelectric device, floor mat or manual switch.

CIRCULATION PATH is an exterior or interior way of passage from one place to another for pedestrians, including, but not limited to, walks, hallways, courtyards, stairways and stair landings.

CLEAR means unobstructed.

CLEAR FLOOR SPACE is the minimum unobstructed floor or ground space required to accommodate a single, stationary wheelchair and occupant.

CLOSED-CIRCUIT TELEPHONE is a telephone with dedicated line(s) such as a house phone, courtesy phone or phone that must be used to gain entrance to a facility.

COMMON USE AREAS is those interior and exterior rooms, spaces or elements that are made available for the use of a restricted group of people (for example, occupants of a homeless shelter, the occupants of an office building or the guests of such occupants).

COMPLY WITH means to meet one or more specifications of these regulations.

CROSS SLOPE is the slope that is perpendicular to the direction of travel (as differentiated from running slope).

CURB CUT is an interruption of a curb at a pedestrian way, which separates surfaces that are substantially at the same elevation.

CURB RAMP is a sloping pedestrian way, intended for pedestrian traffic, which provides access between a walk or sidewalk and a surface located above or below an adjacent curb face, as differentiated from a ramp.

DETECTABLE WARNING is a standardized surface or feature built into or applied to walking surfaces or other elements to warn visually impaired persons of hazards in the path of travel. Only approved DSA-AC detectable warning products and directional surfaces shall be installed as provided in the California Code of Regulations (CCR), Title 24, Part 1, Articles 2, 3 and 4. Refer to CCR Title 24, Part 12, Chapter 12-11A and B for building and facility access specifications for product approval for detectable warning products and directional surfaces.

Detectable warning products and directional surfaces installed after January 1, 2001, shall be evaluated by an independent entity, selected by the Department of General Services, Division of the State Architect—Access Compliance, for all occupancies, including transportation and other outdoor envi-

ronments, except that when products and surfaces are for use in residential housing, evaluation shall be in consultation with the Department of Housing and Community Development. See Government Code Section 4460.

DWELLING UNIT is a single unit of residence for a family of one or more persons. Examples of dwelling units covered by this chapter include condominiums, an apartment unit within an apartment building and other types of dwellings in which sleeping accommodations are provided but toileting or cooking facilities are shared by occupants of more than one room or portion of the dwelling. Examples of the latter include dormitory rooms and sleeping accommodations in shelters intended for occupancy as residences for homeless persons.

ELEMENT is an architectural or mechanical component of a building, facility, space or site; for example, a telephone, curb ramp, door, drinking fountain, seating or water closet.

ELEVATOR, PASSENGER is an elevator used primarily to carry passengers.

ENTRANCE means any access point to a building or portion of a building or facility used for the purpose of entering. An entrance includes the approach walk, the vertical access leading to the entrance platform, the entrance platform itself, vestibules if provided, the entry door(s) or gate(s), and the hardware of the entry door(s) or gate(s).

EQUIVALENT FACILITATION is an alternate means of complying with the literal requirements of these standards and specifications that provides access in terms of the purpose of these standards and specifications. See Section 109.1.

In determining equivalent facilitation, consideration shall be given to means that provide for the maximum independence of persons with disabilities while presenting the least risk of harm, injury or other hazard to such persons or others.

EXIT. See Section 1002.1.

FACILITY (or FACILITIES) is a building, structure, room, site, complex or any portion thereof that is built, altered, improved or developed to serve a particular purpose. Facilities shall include all or any portion of buildings, structures, site developments, complexes, equipment, roads, walks, sidewalks, passageways, parking lots or other real or personal property located on a site.

GRAB BAR is a bar for the purpose of being grasped by the hand for support.

GUARD (or GUARDRAIL). See Section 1002.1.

HANDRAIL. See Section 1002.1.

HEALTH CARE PROVIDER. See “Professional office of a health care provider.”

IF, IF...THEN denotes a specification that applies only when the conditions described are present.

INDEPENDENT ENTITY. See Section 202. Detectable warning products and directional surfaces installed after January 1, 2001, shall be evaluated by an independent entity, selected by the Department of General Services, Division of the State Architect—Access Compliance, for all occupancies, including transportation and other outdoor environments, except that when products and surfaces are for use in residen-

tial housing evaluation shall be in consultation with the Department of Housing and Community Development. See Government Code Section 4460.

INTERNATIONAL SYMBOL OF ACCESSIBILITY is that symbol adopted by Rehabilitation International's 11th World Congress for the purpose of indicating that buildings and facilities are accessible to persons with disabilities. See Figure 11B-6.

KICK PLATE is an abrasion-resistant plate affixed to the bottom portion of a door to prevent a trap condition and protect its surface.

LEVEL AREA is a specified surface that does not have a slope in any direction exceeding one unit vertical in 50 units horizontal (2-percent slope).

LIFT, PLATFORM (WHEELCHAIR). See "Platform (Wheelchair) Lift."

MARKED CROSSING is a crosswalk or other identified path intended for pedestrian use in crossing a vehicular way.

MAY denotes an option or alternative.

NEWLY CONSTRUCTED. See Chapter 11A, Section 1107A.14-N.

NOSE, NOSING is that portion of a stair tread or landing at the top of a stairway flight projecting beyond the face of the riser immediately below.

OPEN RISER is the space between two adjacent stair treads not closed by a riser.

OPERABLE PART is a part of a piece of equipment or appliance used to insert or withdraw objects, or to activate, deactivate or adjust the equipment or appliance (for example, coin slot, pushbutton, handle).

PASSAGE DOOR is a door other than an exit door through which persons may traverse.

PATH OF TRAVEL is a passage that may consist of walks and sidewalks, curb ramps and pedestrian ramps, lobbies and corridors, elevators, other improved areas or a necessary combination thereof, that provides free and unobstructed access to and egress from a particular area or location for pedestrians and/or wheelchair users. A "path of travel" includes a continuous, unobstructed way of pedestrian passage by means of which a particular area may be approached, entered and exited, and which connects a particular area with an exterior approach (including sidewalks, streets, and parking areas), an entrance to the facility, and other parts of the facility. In existing buildings, when alterations, structural repairs or additions are made, the term "path of travel" also includes the sanitary facilities, telephones, drinking fountains and signs serving the altered area.

PEDESTRIAN is an individual who moves in walking areas with or without the use of walking assistive devices such as crutches, leg braces, wheelchairs, white cane, service animal, etc.

PEDESTRIAN GRADE SEPARATION is a structure erected over or under an obstacle such as a freeway, roadway, street, railroad, stream, etc., and intended primarily for pedestrian use.

PEDESTRIAN WAY is a route by which a pedestrian may pass.

PLATFORM. See Section 410.2.

PLATFORM (WHEELCHAIR) LIFT is a hoisting and lowering mechanism equipped with a car or platform or support that serves two landings of a building or structure and is designed to carry a passenger or passengers and (or) luggage or other material a vertical distance as may be allowed.

PRIMARY ENTRY LEVEL is the floor or level of the building on which the primary entry is located.

PROFESSIONAL OFFICE OF A HEALTH CARE PROVIDER is a location where a person or entity, regulated by the State to provide professional services related to the physical or mental health of an individual, makes such services available to the public. The facility housing the professional office of a health care provider only includes floor levels housing at least one health care provider; or any floor level designed or intended for use by at least one health care provider.

PUBLIC USE AREA means interior or exterior rooms or spaces of a building that are made available to the general public and does not include common use areas. Public use areas may be provided at a building that is privately or publicly owned.

PUBLIC WAY. See Section 1002.1.

RAIL TRANSIT BOARDING PLATFORM. See "Transit boarding platform."

RAMP is a walking surface which has a running slope greater than one unit vertical in 20 units horizontal (5-percent slope) intended for pedestrian traffic and as differentiated from a curb ramp.

RISER is the upright member between two adjacent stair treads.

RUNNING SLOPE is the slope that is parallel to the direction of travel (as differentiated from cross slope).

SHALL denotes a mandatory specification or requirement.

SHOPPING CENTER (or SHOPPING MALL) is one or more sales or rental establishments or stores. A shopping center may include a series of buildings on a common site, connected by a common pedestrian access route on, above or below the ground floor; that is either under common ownership or common control or developed either as one project or as a series of related projects. For the purposes of this section, "shopping center" or "shopping mall" includes a covered mall building.

SHOULD denotes an advisory specification or recommendation.

SIDEWALK. See Section 202.

SLEEPING ACCOMMODATIONS are rooms in which people may sleep; for example, dormitory and hotel or motel guest rooms or suites.

SPECIFIED PUBLIC TRANSPORTATION is transportation by bus, rail or any other conveyance (other than by aircraft) that provides the general public with general or special

service (including charter service) on a regular and continuing basis.

STAGE. See Section 410.2.

STAIR. See Section 1002.1.

STAIRWAY. See Section 1002.1.

STORY means that portion of a building included between the upper surface of any floor and the upper surface of the floor next above, except that the topmost story shall be that portion of a building included between the upper surface of the topmost floor and the ceiling or roof above. If the finished floor level directly above a basement or unused under-floor space is more than 6 feet (1829 mm) above grade for more than 50 percent of the total perimeter or is more than 12 feet (3658 mm) above grade at any point, the basement or unused under-floor space shall be considered as a story. There may be more than one floor level within a story as in the case of a mezzanine or mezzanines.

STORY, FIRST means the lowest story in a building which qualifies as a story and which provides the basic services or functions for which the building is used. A floor level in a building having only one floor level shall be classified as a first story, if the floor level is not more than 4 feet (1219 mm) below grade, for more than 50 percent of the total perimeter, or more than 8 feet (2438 mm) below grade at any point.

STRUCTURAL FRAME is considered to be the columns and the girders, beams, trusses and spandrels having direct connections to the columns and all other members which are essential to the stability of the building as a whole.

TEXT TELEPHONE is machinery or equipment that employs interactive text-based communications through the transmission of coded signals across the standard telephone network. Text telephones can include, for example, devices known as TTYs (teletypewriters) or computers.

TRANSIENT LODGING is a building, facility or portion thereof, excluding inpatient medical care facilities, that contains one or more dwelling units or sleeping accommodations. Transient lodging may include, but is not limited to, resorts, group homes, hotels, motels and dormitories.

TRANSIT BOARDING PLATFORM is a horizontal, generally level surface, whether raised above, recessed below or level with a transit rail, from which persons embark/disembark a fixed rail vehicle.

TREAD is the horizontal member of a step.

VEHICULAR WAY is a route intended for vehicular traffic, such as a street, driveway or parking lot.

WALK is a surfaced pedestrian way not located contiguous to a street used, by the public. (As differentiated from the definition of "Sidewalk" in Section 202.)

WORK STATION is an area defined by equipment and/or work surfaces intended for use by employees only, and generally for one or a small number of employees at a time. Examples include ticket booths; the employee side of grocery store checkstands; the bartender area behind a bar; the employee side of snack bars, sales counters and public counters; guardhouses; toll booths; kiosk vending stands; lifeguard stations;

maintenance equipment closets; counter and equipment areas in restaurant kitchens; file rooms; storage areas; etc.

SECTION 1103B BUILDING ACCESSIBILITY

1103B.1 Scope. Accessibility to buildings or portions of buildings shall be provided for all occupancy classifications except as modified or enhanced by this chapter. Occupancy requirements in this chapter may modify general requirements, but never to the exclusion of them. When a building or facility contains more than one use, the occupancy specific accessibility provisions for each portion of the building or facility shall apply.

An accessible route of travel complying with Section 1114B.1.2 shall connect all elements and spaces within a building or facility. Multistory buildings and facilities must provide access to each level, including mezzanines, by ramp or passenger elevator complying with Section 1116B. If more than one elevator is provided, each passenger elevator shall comply with Section 1116B.

Exceptions:

1. Floors or portions of floors not customarily occupied, including, but not limited to, nonoccupiable or employee spaces accessed only by ladders, catwalks, crawl spaces, very narrow passageways or freight (nonpassenger) elevators, and frequented only by service personnel for repair or maintenance purposes: such spaces as elevator pits and elevator penthouses, piping and equipment catwalks, and machinery rooms.
2. The following types of privately funded multistory buildings do not require a ramp or elevator above and below the first floor:
 - 2.1. Multistoried office buildings (other than the professional office of a health care provider) and passenger vehicle service stations less than three stories high or less than 3,000 square feet (279 m²) per story.
 - 2.2. Any other privately funded multistoried building that is not a shopping center, shopping mall or the professional office of a health care provider, or a terminal, depot or other station used for specified public transportation, or an airport passenger terminal (In such a facility, any area housing passenger services, including boarding and debarking, loading and unloading, baggage claim, dining facilities, and other common areas open to the public must be on an accessible route from an accessible entrance) and that is less than three stories high or less than 3,000 square feet (279 m²) per story if a reasonable portion of all facilities and accommodations normally sought and used by the public in such a building are accessible to and usable by persons with disabilities.

The elevator exception set forth in this section does not obviate or limit in any way the obligation to comply with the other accessibility requirements in this code. For example, floors above or below the accessible ground floor must meet the requirements of this section except for elevator service. If toilet or bathing facilities are provided on a level not served by an elevator, then toilet or bathing facilities must be provided on the accessible ground floor.

If a building or facility is eligible for this exception but a passenger elevator is nonetheless planned, that elevator shall meet the requirements of Section 1116B and shall serve each level in the building. A passenger elevator that provides service from a garage to only one level of a building or facility is not required to serve other levels.

1103B.2 Distance to elevators. In new construction of buildings and only where elevators are required, pursuant to Section 1103B.1, and which exceed 10,000 square feet (929 m²) on any floor, an accessible means of vertical access via ramp, elevator or lift shall be provided within 200 feet (60 960 mm) of travel of each stair and each escalator. In existing buildings that exceed 10,000 square feet (929 m²) on any floor and in which elevators are otherwise required pursuant to Section 1103B.1, whenever a newly constructed means of vertical access is provided via stairs or an escalator, an accessible means of vertical access via ramp, elevator or lift shall be provided within 200 feet (60 960 mm) of travel of each new stair or escalator.

Exception: Stairs used solely for emergency egress.

SECTION 1104B ACCESSIBILITY FOR GROUP A OCCUPANCIES

1104B.1 General. All Group A occupancies shall be accessible as provided in this chapter. See also the general requirements in Section 1114B.1.1.

1104B.2 Assistive-listening systems in assembly areas. Assembly areas, conference and meeting rooms shall provide assistive-listening systems for persons with hearing impairments as provided in this section.

Exception: This section does not apply to systems used exclusively for paging, or background music, or a combination of these two uses.

- 1. Number of personal receivers required.** The minimum number of receivers to be provided shall be equal to 4 percent of the total number of seats, but in no case less than two.
- 2. Types of listening systems.** Types of assistive-listening systems include, but are not limited to, audio-induction loops, radio frequency systems (AM or FM) and infrared transmission.
- 3. Location.** If the assistive-listening system provided is limited to specific areas or seats, then such areas or seats shall be within a 50-foot (15 240 mm) viewing distance of the performing area.
- 4. Signage.** A sign shall be posted in a prominent place (for example, a customer service counter, ticket booth or assembly area entrance) indicating the availability of assistive-listening devices. The sign complying with Sec-

tion 1117B.5.1, Items 2 and 3 shall include the International Symbol of Access for Hearing Loss complying with Figure 11B-14C and include wording that states, "Assistive-Listening System Available."

- 5. Fees and charges.** Nothing in this section shall preclude a facility charging for such assistive-listening system its usual fee for audiovisual equipment. However, no surcharge may be placed directly on any particular individual with a disability or any group of individuals with disabilities to cover the costs of such equipment.
- 6. Permanent and portable systems.** Permanently installed assistive-listening systems are required in areas if (1) they accommodate at least 50 persons or if they have audio-amplification systems, and (2) they have fixed seating. If portable assistive-listening systems are used for conference or meeting rooms, the system may serve more than one room. An adequate number of electrical outlets or other supplementary wiring necessary to support a portable assistive-listening system shall be provided.

1104B.3 Auditoriums, assembly halls, theaters and related facilities.

1104B.3.1 Seating. In all assembly places where seating is provided, there shall be spaces for persons using wheelchairs and semi-ambulant persons, as provided in this section.

Exceptions:

- In existing buildings and facilities when the enforcing agency determines that compliance with the seating requirements of this code would create an unreasonable hardship, such requirements shall not apply. When the unreasonable hardship finding is applied, at least 1 percent of the total seating provided shall be accessible to and usable by persons with disabilities who use wheelchairs, and such seating shall comply with the level requirements and the individual space requirements of this code.
- When an existing theater is subdivided into more than one facility having upper levels not accessible by ramp or elevator, and the enforcing agency determines that full compliance with this code would create an unreasonable hardship, such upper levels need not be made accessible, provided all facilities at grade are accessible and any event, showing of motion pictures or other activities made available to the public in all of the facilities are scheduled to ensure that all such functions are available to the public in the accessible facility.

1104B.3.2 Accessibility to key facilities. Seating for persons with disabilities shall be accessible from the main lobby or from a primary entrance, together with related toilet facilities.

1104B.3.3 Variety of locations. Accessible seating or accommodations in places of public amusement and resort, including theaters, concert halls and stadiums, shall be provided in a variety of locations so as to provide persons with

disabilities a choice of admission prices otherwise available to members of the general public.

1104B.3.4 Wheelchair spaces.

1. The number of such spaces is as shown in Table 11B-1.

**TABLE 11B-1
WHEELCHAIR SEATING SPACES**

SEATING CAPACITY	NO. OF WHEELCHAIR SEATING SPACES
4 to 25	1
26 to 50	2
51 to 300	4
301 to 500	6

In addition, 1 percent, but not less than one, of all fixed seats, shall be aisle seats with no armrests on the aisle side, or removable or folding armrests on the aisle side. Each such seat shall be identified by a sign or marker with the International Symbol of Accessibility (see Figure 11B.6). Signage notifying patrons of the availability of such seats shall be posted at the ticket office. Signs and markers shall comply with Section 1117B.5.1, Items 2 and 3, as applicable.

2. When the seating capacity exceeds 500, one additional wheelchair seating space shall be provided for each total seating capacity increase of 100.
3. The ground or floor at spaces shall be level and shall comply with Section 1124B.

1104B.3.5 Placement of wheelchair locations. Wheelchair areas shall be an integral part of any fixed seating plan, and shall be arranged so as to provide persons with disabilities a choice of admission prices and lines of sight comparable to those for members of the general public. Each wheelchair area shall adjoin an accessible route which shall also serve as a means of egress in case of emergency. At least one companion fixed seat shall be provided next to each wheelchair seating area. When the seating capacity exceeds 300, wheelchair spaces shall be provided in more than one location in addition to complying with Section 1104B.3.3.

Exceptions:

1. Accessible viewing positions where seating capacity is less than 300 may be clustered for bleachers, balconies and other areas having sight lines that require slopes of greater than one unit vertical in 20 units horizontal (5-percent slope). Equivalent accessible viewing positions may be located on levels having accessible egress.
2. Where it is determined that dispersing accessible seating throughout an existing assembly area would create an unreasonable hardship, accessible seating areas may be clustered. Each accessible seating area shall have provisions for companion seating and shall be located on an accessible route that also serves as a means of emergency egress.

1104B.3.6 Size of wheelchair location. Each wheelchair location shall provide minimum clear floor or ground space

as shown in Figure 11B-15, and shall adjoin an egress aisle on at least one side.

1104B.3.7 Removable seats. Readily removable seats may be installed in these wheelchair spaces when such spaces are not required to accommodate wheelchair users.

1104B.3.8 Seating for semi-ambulant individuals. In addition to spaces provided for wheelchair users as noted in Sections 1104B.3.4 through 1104B.3.7 above, there shall be provided seating for semi-ambulant individuals. The number of such seating shall be equal to at least 1 percent of the total seating and shall be no fewer than two. Such seats shall provide at least 24 inches (610 mm) clear leg space between the front of the seat to the nearest obstruction or to the back of the seat immediately in front.

1104B.3.9 Life safety. In determining the location of seating for persons with disabilities, life safety shall be considered, and all seating provided must comply with the fire and panic safety requirements of the State Fire Marshal.

1104B.3.10 Access to performing areas. An accessible route shall connect wheelchair seating locations with performing areas, including stages, arena floors, dressing rooms, locker rooms and other spaces used by performers.

1104B.3.11 Stages, enclosed and unenclosed platforms and orchestra pits. Stages, enclosed and unenclosed platforms and orchestra pits shall be made accessible to persons with disabilities.

Exceptions:

1. When the enforcing agency finds that requiring compliance with this code, for an enclosed or unenclosed platform or depressed area not more than 24 inches (610 mm) above or below an adjacent accessible level, would create an unreasonable hardship, the enclosed and unenclosed platform or depressed area shall be made accessible by a portable ramp with a slope not exceeding one unit vertical in 12 units horizontal (8.33 percent slope).
2. In existing buildings and facilities, all stages, enclosed or unenclosed platforms, and orchestra pits need not be accessible when the enforcing agency determines that compliance with this code would create an unreasonable hardship.

1104B.3.12 Ticket booths. Customer and employee sides of ticket booths and of concession and refreshment sales facilities shall be made accessible to persons with disabilities.

1104B.3.13 Miscellaneous areas. Public toilets and other public areas shall be made accessible to persons with disabilities.

1104B.4 Stadiums, grandstands, bleachers, athletic pavilions, gymnasiums and miscellaneous sport-related facilities.

1104B.4.1 Spectator seating. Spectator seating shall comply with Section 1104B.3.

1104B.4.2 Ticket booth. The customer side of a ticket booth shall be, and the employee side may be, accessible.

1104B.4.3 Participation areas. Participation areas shall be accessible to persons with disabilities, including the following listed and similar activity areas:

1. Tennis, racquetball and handball courts.
2. Gymnasium floor areas and general exercise rooms.
3. Basketball, volleyball and badminton courts, and bowling lanes.
4. Swimming pool deck areas shall be accessible, and a mechanism to assist persons with disabilities in gaining entry into the pool and in exiting from the pool shall be provided. Such a mechanism may consist of a swimming pool lift device that meets all of the following criteria:
 - 4.1. Have a seat that meets all of the following:
 - 4.1.1. The seat shall be rigid;
 - 4.1.2. The seat shall be not less than 17 inches (423 mm) and not more than 19 inches (483 mm), inclusive of any cushioned surface that might be provided, above the pool deck;
 - 4.1.3. The seat shall have two armrests. The armrest on the side of the seat by which access is gained shall be either removable or fold clear of the seat;
 - 4.1.4. The seat shall have a back support that is at least 12 inches (305 mm) tall;
 - 4.1.5. The seat shall have an occupant restraint for use by the occupant of the seat, and the restraint shall meet the standards for operable controls in compliance with Section 1117B.6, Items 1 through 4.
 - 4.2. Be capable of unassisted operation from both the deck and water levels.
 - 4.3. Be stable and not permit unintended movement when a person is getting into or out of the seat.
 - 4.4. Be designed to have a live-load capacity of not less than 300 pounds (137 kg).
 - 4.5. Be positioned so that, if the pool has water of different depths, it will place the operator into water that is at least 3 feet (914 mm) deep.
 - 4.6. Lower the operator at least 18 inches (457 mm) below the surface of the water.
5. Athletic team rooms and facilities, playing fields and running tracks.

1104B.4.4 Clubrooms. Clubrooms shall be made accessible to persons with disabilities.

1104B.4.5 Sanitary and locker facilities. Where spectator and/or participant sanitary and/or locker facilities are provided, they shall conform with the requirements in Section 1115B.

Exceptions:

1. Where the enforcing agency determines that compliance with these regulations would create an unreasonable hardship, an exception may be granted

when equivalent facilitation is provided through the use of other methods or materials.

2. In existing buildings, when the enforcing agency finds that compliance with regulations would create an unreasonable hardship, an exception may be granted when all of the following minimum conditions are met:

- 2.1. When the total seating does not exceed 5,000 at least 1 percent of such seating shall be accessible to and usable by persons with disabilities. When the total seating provided exceeds 5,000, one additional seat for each 2,000 seats provided over 5,000 shall be accessible to and usable by persons with disabilities.
- 2.2. Sanitary facilities, ticket booths, clubrooms, concessions and refreshment facilities shall be accessible.
- 2.3. One of each type of participation area is usable and accessible.

1104B.5 Dining, banquet and bar facilities.

1. **General.** Dining, banquet, and bar facilities shall be made accessible to persons with disabilities as provided in this section. All areas where each type of functional activity occurs shall be made accessible.

Exceptions:

1. In existing buildings, when the enforcing agency determines that compliance with any regulation under this section would create an unreasonable hardship, an exception shall be granted when equivalent facilitation is provided.
2. In existing buildings, these regulations shall not apply when legal or physical constraints would not allow compliance with these regulations or equivalent facilitation without creating an unreasonable hardship. See Section 109.1.5.
2. **Entrance.** Access to these facilities shall be provided at entrances and exits as required by Section 1133B.1.1.
3. **Raised or sunken areas.** All raised or sunken areas, including dining areas, loggias and outdoor seating areas, shall be accessible. A raised platform where a head table or speaker's lectern is located shall be accessible. Open edges of raised or sunken areas shall be protected as required by Sections 1013 Guards, 1133B.8.1 Warning Curbs, or by other means as required by this code. For existing buildings, see Section 1120B, Floors and Levels.
4. **Seating.** Each dining, banquet and bar area shall have one wheelchair seating space for each 20 seats, with at least one minimum wheelchair seating space per functional area. Such seating shall be designed and arranged to permit use by wheelchair occupants, and shall comply with Section 1122B, Fixed or Built-in Seating, Tables, and Counters. Access to such seating spaces shall be provided with main aisles not less than 36 inches (914 mm) clear width. In establishments where separate areas are designated for smoking and nonsmoking patrons, the

required number of accessible fixed tables (or counters) shall be proportionally distributed between the smoking and nonsmoking areas. Accessible seating spaces shall be integrated with general seating to allow a reasonable selection of seating area and to avoid having one area specifically highlighted as the area for persons with disabilities. The ratio of accessible seating is based on the total number of seats provided. Where food or drink is served at counters exceeding 34 inches (865 mm) in height for consumption by customers seated or standing at the counter, a portion of the main counter which is 60 inches (1525 mm) in length minimum shall be provided in compliance with Section 1122B.

5. **Food service aisles.** Food service aisles shall be a minimum of 36 inches (914 mm) of clear width with a preferred width of 42 inches (1067 mm) where passage of stopped wheelchairs by pedestrians is desired. Tray slides shall be mounted no higher than 34 inches (864 mm) above the floor as shown in Figure 11B-16. If self-service shelves are provided, at least 50 percent of each type must be within the reach ranges in Sections 1118B.5 and 1118B.6.
6. **Tableware and condiment areas.** Self-service tableware, dishware, condiments, food and beverage display shelves and dispensing devices shall comply with Sections 1118B and 1122B.4. See Figure 11B-17.
7. **Restrooms.** Restrooms and powder rooms shall conform to the requirements in Section 1115B.
8. **Food preparation areas.** Access to food preparation areas shall comply with the provisions for entrance doors and doorways in Section 1008, and aisles in Sections 1014.4 and 1014.4.1.

1104B.6 Religious facilities.

1104B.6.1 General. Religious facilities shall be made accessible to persons with disabilities as provided in this section.

Exception: In existing buildings, when the enforcing agency determines that compliance with any regulation under this section would create an unreasonable hardship, an exception shall be granted when equivalent facilitation is provided.

1104B.6.2 Sanctuary. Sanctuary areas shall be made accessible to persons with disabilities.

1104B.6.2.1 Wheelchair seating spaces in these areas shall conform to the requirements in Section 1104B.3.1.

1104B.6.2.2 Wheelchair access shall be provided to raised platforms, choir rooms, choir lofts, performing areas and other similar areas.

Exception: In existing buildings, these regulations shall not apply to choir lofts when the enforcing agency determines that such compliance would create an unreasonable hardship.

1104B.6.3 Assembly areas. Assembly areas shall be made accessible to persons with disabilities. Enclosed and unenclosed platforms and stages in assembly areas shall conform to these requirements.

1104B.6.4 Classrooms and offices. Classrooms and offices shall have entry doors that conform to the requirements in Chapter 10.

1104B.6.5 Sanitary facilities. Sanitary facilities shall conform to the requirements in Section 1115B.

SECTION 1105B ACCESSIBILITY FOR GROUP B OCCUPANCIES

Group B occupancies shall be accessible as provided in this chapter. See also the general requirements in Section 1114B.1.1.

Exceptions:

1. In existing buildings, when the enforcing agency determines that compliance with any regulation under this section would create an unreasonable hardship, an exception shall be granted when equivalent facilitation is provided.
2. In existing buildings, the provisions of this section shall not apply when legal or physical constraints will not allow compliance with these building standards or equivalent facilitation without creating an unreasonable hardship. See Section 109.1.5.
3. For floors and levels in new and existing buildings, see Section 1120B.

1105B.1 General. The provisions of this section apply to the specified types of facilities and identify specific requirements of accessibility and usability which shall be provided for each of the listed occupancy uses.

1105B.2 Group B occupancies. Group B occupancies used for assembly purposes shall conform to the requirements as specified in Section 1114B.1.1. For floors and levels in dining, banquet and bar facilities, see Section 1120B.

1105B.3 Office buildings and personal and public service facilities. Office buildings and personal and public service facilities shall conform to the provisions of this section.

1105B.3.1 Facilities covered. Facilities covered in this section are those that are used by the public as customers, clients, visitors or which are potentially places of employment and shall include, but not be limited to, the following requirements:

1. All types of general and specialized business professional offices, including those related to professional medicine or dentistry, insurance, real estate, attorneys, credit bureaus, consultants, counseling and accounting.
2. All types of sales establishments, including outlets for all general and special merchandise and equipment, including personal and household furnishings and supplies, foods, sporting equipment, office supplies, vehicles and related parts and supplies, building materials and pet shops.
3. All personal and public service facilities, including banks, savings and loan companies, credit unions, newspaper and printing establishments, photographic studios, launder mats, cleaning and laundry

outlets, veterinarian clinics and hospitals, automobile rental agencies, travel bureaus, public utility facilities, police stations and detention facilities, courtrooms and fire stations.

4. In addition to the requirements of this section, all areas used for business transactions with the public shall comply with Sections 1110B.1, Sales, and 1122B, Fixed or Built-in Seating, Tables, and Counters.

1105B.3.2 Business and professional offices. Areas to be made accessible include the following:

1. Client and visitor areas and office areas, together with related toilet rooms.
2. Conference rooms, counseling rooms or cubicles and similar areas.
3. Employee work areas shall have a minimum of 36 inches (914 mm) clear width access, except as modified in other portions of these regulations. See Sections 1133B.6.1 and 1133B.6.2.
4. Professional medical and dental offices shall be made accessible and shall also comply with Section 1109B.

1105B.3.3 Personal and public service facilities. Areas to be made accessible include the following:

1. Client and visitor areas, office areas and related toilet rooms shall be made accessible.
2. Employee work areas shall have a minimum of 36 inches (914 mm) clear width access, except as modified in other portions of these regulations. See Sections 1133B.6.1 and 1133B.6.2.
3. Automated teller machines used by a financial institution and its customers for the primary purposes of executing financial transactions shall be located on an accessible route of travel complying with Section 1114B.1.2 and shall comply with Section 1117B.7.

1105B.3.4 Public utility facilities. Areas to be made accessible include the following:

1. Office areas, meeting rooms and similar areas together with related toilet rooms shall be made accessible.
2. Public tour areas, to the extent that such public tours are conducted through or about a facility, or where the public is permitted to walk in such areas, shall provide accessibility in those portions of the facility and grounds where this occurs.

Exceptions:

1. Facilities located in operational areas which would not have any reasonable availability to or usage by persons who use wheelchairs for mobility are not subject to the wheelchair accessibility requirements of these regulations.
2. When the enforcing agency determines that compliance with this subsection would create an unreasonable hardship, an exception

to such provision shall be granted when equivalent facilitation is provided.

3. Visitor overlook facilities, orientation areas and similar public use areas, and any sanitary facilities that serve these facilities shall be made accessible.
4. Where public parking is provided, spaces shall be provided for persons with disabilities as specified in Sections 1129B and 1130B.

1105B.3.5 Police department, law enforcement, fire department facilities and courtrooms. Areas to be made accessible include the following:

1. Office areas, conference rooms, classrooms, dispatch rooms and similar areas, along with related sanitary facilities, shall be made accessible.
2. Detention area visitor rooms shall be made accessible.
3. At least one detention cell facility with supporting sanitary facilities shall be made accessible.
4. Courtroom areas, including the judge's chambers and bench, counsel tables, jury box, witness stand and public seating area shall be made accessible.

1105B.3.6 Miscellaneous general standards.

1. Circulation aisles and pedestrian ways shall be sized according to functional requirements and in no case shall be less than 36 inches (914 mm) in clear width.
2. **Storage areas.** The doorway providing access to all such areas shall not be less than 32 inches (813 mm) in clear width. Storage areas shall be made accessible in the number and dimensions provided in Section 1125B.

SECTION 1106B ACCESSIBILITY FOR GROUP E OCCUPANCIES

1106B.1 General. Group E occupancies shall be accessible as provided in this chapter. See also the general requirements in Section 1114B.1.1.

Exceptions:

1. In existing buildings, when the enforcing agency determines that compliance with any regulation under this section would create an unreasonable hardship, an exception shall be granted when equivalent facilitation is provided.
2. In existing buildings, where the enforcing agency determines that, because of physical constraints, compliance with these regulations or equivalent facilitation would create an unreasonable hardship, these regulations shall not apply. See Section 109.1.5.

1106B.2 Laboratory rooms. Laboratory rooms shall have at least one workstation and at least 5 percent of all workstations accessible to and usable by persons with disabilities in compliance with Section 1118B, Space Allowance and Reach Ranges, and Section 1122B, Fixed or Built-in Seating, Tables and Counters.

Exception: Where the enforcing agency determines that it would create an unreasonable hardship to require compliance with these regulations for special use rooms such as laboratory preparation rooms, supply rooms, small research laboratories, and areas containing specialized equipment not readily usable by persons with particular disabilities, such facilities need not comply with these regulations, except that a clear width of 32 inches (813 mm) shall be maintained into such rooms.

1106B.3 Teaching facility cubicles, study carrels, etc. Teaching facility cubicles, study carrels, etc., shall have 5 percent, but always at least one cubicle or carrel in each group (language, dental, audiovisual, typing, drafting, darkrooms, etc.) made accessible to and usable by persons with disabilities in compliance with Section 1118B, Space Allowance and Reach Ranges, and Section 1122B, Fixed or Built-in Seating, Tables and Counters.

1106B.4 Library general use areas.

- 1. General.** Library general use areas such as those housing card files, book stacks, periodicals, reading and study areas, reference areas, information desks, circulation counters, reserve areas, special facilities or collections, etc., shall be made accessible to persons with disabilities.
- 2. Open book stacks.** Open book stacks (those available for customer use) shall be on an accessible route complying with Section 1114B.1.2, may be of normal height, and shall have main aisles no less than 44 inches (1118 mm) in clear width and side, range and end aisles no less than 36 inches (914 mm) in clear width.

In existing buildings, multitiered, closed book stacks (those restricted to employee use) are exempt from these accessibility standards.

- 3. Height of book shelves.** Unless an attendant is available to assist persons with disabilities, all book shelving shall be located not more than 54 inches (1372 mm) above the floor.
- 4. Card catalogs and magazine displays.** Minimum clear aisle space and maximum reach heights at card catalogs and magazine displays shall comply with Section 1118B, with a height of 48 inches (1219 mm) preferred irrespective of reach allowed.
- 5. Reading and study areas.** At least 5 percent or a minimum of one of each element of fixed seating, tables, study carrels, computers or similar workstations shall be on an accessible route complying with Section 1114B.1.2, and shall comply with Section 1118B, "Space Allowance and Reach Ranges", Section 1122B, "Fixed or Built-in Seating, Tables, and Counters" and Section 1133B.6 "Aisles".
- 6. Check-out areas.** At least one lane at each check-out area shall be on an accessible route complying with Section 1114B.1.2, and shall have a portion of the counter which is at least 36 inches (914 mm) in length with a maximum height of 34 inches (864 mm) above the finish floor with a 36 inch (914 mm) wide aisle on the customer side.

Any traffic control or book security gates or turnstiles shall comply with Section 1133B.2.3.4.

SECTION 1107B FACTORIES AND WAREHOUSES

Factories and warehouses shall conform to the provisions of this section, Sections 1103B.1 and 1103B.1, Exception 2, for multistory buildings. See also the general requirements in Section 1114B.1.1.

Exception: In existing buildings, when the enforcing agency determines that compliance with any regulation under this section would create an unreasonable hardship, an exception shall be granted when equivalent facilitation is provided.

1107B.1 Factories.

1. Major or principal floor areas shall be made accessible.
2. Office areas shall be made accessible.
3. Sanitary facilities serving these areas shall be made accessible.

1107B.2 Warehouses.

1. Miscellaneous warehousing areas which are located on the floor nearest grade and those areas on other floors that are otherwise provided with access by level entry, ramp or elevator shall be made accessible.
2. Office areas shall be made accessible.
3. Sanitary facilities serving these areas shall be made accessible.

SECTION 1108B ACCESSIBILITY FOR GROUP H OCCUPANCIES

1108B.1 General. Group H occupancies shall be accessible as provided in this chapter. See also the general requirements in Section 1114B.1.1.

Exceptions:

1. In existing Group H occupancies, when the enforcing agency determines that compliance with any regulation under this section would create an unreasonable hardship, an exception shall be granted when equivalent facilitation and protection are provided.
2. In existing Group H occupancies, the provisions of this section shall not apply when legal or physical constraints prevent compliance with these building standards or the provisions of equivalent facilitation without creating an unreasonable hardship. See Section 109.1.5.

1108B.2 Accessible sanitation facilities. Accessible sanitation facilities in all Group H occupancies shall be provided as specified in this chapter.

1108B.3 Accessible routes. Entrances, stairs, ramps, doors, turnstiles, corridors, walks, sidewalks and hazards shall provide accessibility as specified in Section 1133B.

1108B.4 Accessible floors and levels. Accessible floors and levels shall comply with the requirements specified in this chapter.

1108B.5 Employee work areas. Employee work areas shall be accessible by means of a 36-inch-minimum (914 mm) aisle width and a 32-inch-minimum (813 mm) clear opening door width, as specified in Sections 1133B.6.1 and 1133B.6.2.

1108B.6 Accessible facilities covered in this chapter are those that are used by the public as customers, clients, visitors or which are potential places of employment.

SECTION 1109B ACCESSIBILITY FOR GROUP I OCCUPANCIES

1109B.1 General. All Group I occupancies shall be accessible as provided in this chapter. See also the general requirements in Section 1114B.1.1.

Exception: In existing buildings, when the enforcing agency determines that compliance with any regulation under this section would create an unreasonable hardship, an exception shall be granted when equivalent facilitation is provided.

1109B.2 Entrance. At least one accessible entrance shall be protected from the weather by canopy or roof overhang. Such entrances shall incorporate a passenger loading zone. Passenger loading zones shall provide an access aisle at least 60 inches (1524 mm) wide and 20 feet (6096 mm) long adjacent and parallel to the vehicle pull-up space. If there are curbs between the access aisle and the vehicle pull-up space, then a curb ramp complying with Chapter 11B shall be provided. Vehicle standing spaces and access aisles shall be level with surface slopes not exceeding one unit vertical in 50 units horizontal (2-percent slope) in all directions. Minimum vertical clearance of 114 inches (2896 mm) at accessible passenger loading zones and along vehicle access routes to such areas from site entrances shall be provided.

Exception: Clinics and other medical facilities that are not intended for patient stays of 24 hours or more, and that are located above the first story of a building, and that do not have a dedicated entrance from the exterior of the building at the first story.

1109B.3 Patient bedrooms and toilet rooms. Patient bedrooms and associated toilet facilities shall be made accessible as follows:

1. Long-term care facilities, including skilled nursing facilities, intermediate care facilities, bed and care and nursing homes shall have at least 50 percent of patient bedrooms and toilet rooms, and all public use and common use areas, accessible.
2. General-purpose hospitals, psychiatric facilities and detoxification facilities shall have at least 10 percent of patient bedrooms and toilets, and all public use and common use areas, accessible.
3. Hospitals and rehabilitation facilities that specialize in treating conditions that affect mobility, or units within either that specialize in treating conditions that affect

mobility, shall have all patient bedrooms and toilets and all public use and common use areas accessible.

Exceptions:

1. In existing buildings, when patient bedrooms are being added or altered as part of a planned renovation of an entire wing, a department, or other discrete area of an existing medical facility, the accessible rooms provided shall comply with Section 1109B.4 and shall be consistent with the percentage of rooms required to be accessible by 1109B.3, until the number of accessible patient bedrooms in the facility equals the overall number that would be required if the facility were newly constructed. (For example, if 20 patient bedrooms are being altered in the obstetrics department of a hospital, 2 of the altered rooms must be made accessible. If, within the same hospital, 20 patient bedrooms are being altered in a unit that specializes in treating mobility impairments, all of the altered rooms must be made accessible.) Where toilet/bathrooms are part of patient bedrooms which are added or altered and required to be accessible, each such patient toilet/bathroom shall comply with Section 1109B.5.
2. In existing buildings, when patient bedrooms are being added or altered individually, and not as part of an alteration of the entire area, the altered patient bedrooms shall comply with Section 1109B.4, unless either: a) the number of accessible rooms provided in the department or area containing the altered patient bedroom equals the number of accessible patient bedrooms that would be required if the percentage requirements of Section 1109B.3 were applied to that department or area; or b) the number of accessible patient bedrooms in the facility equals the overall number that would be required if the facility were newly constructed. Where toilet/bathrooms are part of patient bedrooms which are added or altered and required to be accessible, each such toilet/bathroom shall comply with Section 1109B.5.

1109B.4 Patient bedroom areas. Accessible patient bedrooms shall comply with the following requirements:

1. Each bedroom shall have a turning space measuring 60 inches (1524 mm) clear in diameter, or that is a T-shaped space complying with Figure 11B-12. In rooms with two beds, it is preferable that this space be located between beds.
2. Each bedroom shall have a minimum clear floor space of 36 inches (914 mm) along each side of the bed, and shall provide an accessible route to each side of the bed.
3. Each bedroom shall have an accessible door that complies with Section 1133B.2.

1109B.5 Patient toilet rooms and bathing facilities. Patient toilet rooms and bathing facilities required to be accessible shall comply with Section 1115B.

1109B.6 Diagnostic and treatment areas. Diagnostic and treatment areas and, where applicable, at least one dressing room, sanitary facility, etc., for each unit or suite shall be made accessible.

1109B.7 Waiting areas, offices and sanitary facilities. Waiting areas, offices and sanitary facilities serving them shall be made accessible as covered in other portions of these standards.

1109B.8 Offices and suites. In buildings that house offices and suites of physicians, dentists, etc., all such offices or suites shall be made accessible, subject to other provisions of these regulations.

**SECTION 1110B
ACCESSIBILITY FOR GROUP M OCCUPANCIES**

1110B.1 Sales.

1110B.1.1 General areas. General sales, display and office areas together with related toilet rooms shall be made accessible. See also the general requirements in Section 1114B.1.1.

Exceptions:

1. Minor specialized display areas that do not exceed 200 square feet (18.6 m²) in floor area and to which the general public is excluded need not be made accessible.
2. Offices in sales facilities that do not exceed 5,000 square feet (465 m²) in total area, that are located on nonaccessible levels, need not be made accessible.

1110B.1.2 Work areas. Sales employee workstations shall be located on accessible levels, and the customer side of sales or check-out stations shall be accessible. Employee work areas shall be sized and arranged to provide access to employees in wheelchairs.

1110B.1.3 Check stands. In new construction, check stands, including service counters requiring a surface for transactions, shall be made accessible by providing a 36-inch (914 mm) minimum clear aisle width on the customer side of the check stand. Where check stands are provided, the number of check stands that are accessible shall be as shown in Table 11B-2.

**TABLE 11B-2
CHECK STANDS**

TOTAL NUMBER OF CHECK STANDS OF EACH DESIGN	NUMBER OF CHECK STANDS OF EACH DESIGN TO BE ACCESSIBLE
1 to 4	1
5 to 8	2
9 to 15	3
over 15	3 plus 20% of additional aisles

In new and existing construction, accessible check stands shall provide a minimum clear checkout aisle width of 36 inches (914 mm) with a maximum adjoining counter height not exceeding 38 inches (965 mm) above the finish floor. The top of the counter lip shall not exceed 40 inches (1016 mm)

above the finish floor. Accessible check stands shall always be open to customers with disabilities and shall be identified by a sign clearly visible to those in wheelchairs. The sign shall display the International Symbol of Accessibility in white on a blue background and shall state: "This check stand to be open at all times for customers with disabilities."

In existing buildings, at least one checkout aisle shall be accessible in facilities with less than 5,000 square feet (465 m²) of selling space. In facilities of 5,000 square feet (465 m²) or more of selling space, at least one of each design of checkout aisle shall be made accessible when altered until the number of accessible checkout aisles of each design equals the number required in new construction.

Examples of checkout aisles of different design include those which are specifically designed to serve different functions. A different design includes, but is not limited to, the following features: length of belt or no belt, or permanent signage designating the aisle as an express lane.

1110B.1.4 Point-of-sale machines. All point-of-sale machines used by customers for the primary purpose of executing transactions between the business entity and the customer shall comply with Section 1117B.7.

1110B.1.5 Turnstiles. See Section 1133B.2.3.4.

1110B.1.6 Theft prevention barriers. Where shopping cart theft prevention barriers are used, they shall conform to the following requirements:

1. Each entrance and exit provided for public use shall be accessible to and usable by persons with disabilities.
2. Shopping cart barriers located at a public entrance or exit shall be designed to provide a clear, unobstructed opening at least 32 inches (813 mm) in width for ingress and egress of persons with disabilities.
3. Where gates are used, they shall open in the direction of travel, provide a clear unobstructed opening 32 inches (813 mm) in width and be maintained unlocked during business hours. Gates shall not operate a publicly audible alarm system or require more than 5 foot-pounds of force (22.2 N-m).
4. Where a clear unobstructed opening is provided, a level area is required on both sides of the clear opening or gate which extends a minimum of 44 inches (1118 mm) on each side of the opening and is at least 48 inches (1219 mm) in width.
5. Where a gate is used, the level area on both sides of the clear opening or gate shall be a minimum of 60 inches (1524 mm) in width and extend a minimum of 60 inches (1524 mm) (measured from the gate in a closed position) in the direction of the gate swing. The level area opposite the gate swing shall be a minimum of 48 inches (1219 mm) in width and extend a minimum of 42 inches (1067 mm).
6. Where a gate is used, the bottom of the gate shall be within 3 inches (76 mm) of the surface of the path of travel. The surface of the gate on each side shall be smooth to present no hazard to persons with disabilities using the gate and shall be structurally adequate

to allow it to be opened with the wheelchair foot pedals.

7. The path of travel to and through the clear opening or gate shall be designed to prevent barriers from obstructing it and shall be continuously maintained unobstructed during business hours. Also, the design shall specifically prevent parked vehicles from obstructing ingress and egress.
8. Interior and exterior pedestrian traffic barriers (posts, rails, turnstiles, etc.) shall allow unobstructed travel for persons with disabilities through a 32-inch (813 mm) clear opening.

1110B.2 Miscellaneous general standards.

1110B.2.1 Circulation. Shelves or display units allowing self-service by customers in mercantile occupancies shall be located on an accessible route of travel complying with Section 1114B.1.2. Circulation aisles and pedestrian ways shall be sized according to functional requirements and in no case shall be less than 36 inches (914 mm) in clear width.

1110B.2.2 Storage areas. The doorway providing access to all such areas shall not be less than 32 inches (813 mm) in clear width. Storage areas shall be made accessible in the number and dimensions provided in Section 1125B.

SECTION 1111B ACCESSIBILITY FOR GROUP R OCCUPANCIES

1111B.1 General. Group R occupancies shall be accessible or adaptable as provided in this chapter. Public-use and common use areas serving adaptable guest and/or dwelling units shall be accessible. See also the general accessibility requirements in Section 1114B.1.1.

Exception: When the enforcing agency determines that compliance with any regulation under this section would create an unreasonable hardship, an exception shall be granted when equivalent facilitation is provided.

1111B.2 Public and common use rooms or areas. Public- and common use rooms and similar areas shall be made accessible to persons with disabilities, subject to specific provisions contained in other portions of these regulations. See also general requirements in Section 1114B.1.1.

At least one of each type of amenity (such as washers, dryers and similar equipment installed for the use of occupants) in each common area shall be accessible and shall be located on an accessible route to any accessible unit or sleeping accommodation.

Exception: Where elevators are not required, accessible amenities are not required on inaccessible floors as long as one of each type is provided in common areas on accessible floors.

1111B.3 Recreational facilities. When recreational facilities are provided, including swimming pools, they shall comply with Sections 1104B.4.3 and 1132B.2.

1111B.4 Hotels, motels, inns, dormitories, resorts, homeless shelters, halfway houses, transient group homes and similar places of transient lodging. Hotels, motels, inns, dormitories,

resorts, homeless shelters, halfway houses, transient group homes and similar places of transient lodging shall provide access for persons with disabilities in accordance with the provisions of the accessibility requirements of this California Building Code, except as herein provided.

Facilities with multibed rooms or spaces shall comply with Sections 1111B.4.2 and 1111B.4.3.

Occupancies which are not homeless shelters but are being altered to provide shelter accommodations shall meet the requirements of this section.

1111B.4.1 Available range of accommodations. Accessible guest rooms or suites shall be dispersed among the various classes of sleeping accommodations to provide a range of options applicable to room sizes, costs, amenities provided and the number of beds provided.

1111B.4.2 Guest rooms and suites. Places of transient lodging shall incorporate the accessibility requirements of this code as modified by this chapter in at least one guest room or dormitory room together with their sanitary facilities as required in Table 11B-3. All accessible sleeping rooms or suites required by Table 11B-3 shall comply with the requirements of Section 1111B.4.5 for hearing impaired guests.

1111B.4.2.1 Spaces. Where provided as part of an accessible unit, sleeping room or suite, the following spaces shall be accessible and shall be on an accessible route complying with Section 1114B.1.2:

1. The living area;
2. The dining area;
3. At least one sleeping area;
4. Patios, terraces or balconies;
5. Where full bathrooms are provided, at least one full bathroom (that is, one with a water closet, a lavatory and a bathtub or shower);
6. Where only half baths are provided, at least one half bath;
7. Carports, garages or parking spaces.

1111B.4.2.2 Accessible route. Guest rooms and suites shall be on an accessible route complying with Section 1114B.1.2. An accessible route shall also connect all accessible spaces and elements, including telephones, within the unit, sleeping room or suite.

1111B.4.2.3 Doors.

1111B.4.2.3.1 Doors into and within covered rooms and suites. Doors and doorways designed to allow passage into and within all sleeping rooms, suites or other covered units shall comply with Section 1133B.2.

1111B.4.2.3.2 Doors into and within all other rooms and suites. Doors and doorways designed to allow passage into and within all other sleeping rooms and suites shall comply with Section 1133B.2.2.

1111B.4.2.4 Alterations in existing facilities. When guest rooms are being altered in an existing facility, or

portion thereof, subject to the requirements of this section, at least one guest room or suite that complies with the accessibility requirements of this code as modified by this chapter shall be provided for each 25 guest rooms, or fraction thereof, of rooms being altered until the number of such rooms provided equals the number required to be accessible in Table 11B-3. In addition, at least one guest room or suite that complies with the requirements of Section 1111B.4.5 shall be provided for each 25 guest rooms, or fraction thereof, of rooms being altered until the number of such rooms equals the number required to be accessible in Table 11B-4.

1111B.4.3 Access to beds. Accessible sleeping rooms shall have a 36-inch (914 mm) clear width maneuvering space located along both sides of a bed, except that where two beds are provided, this requirement can be met by providing a 36-inch-wide (914 mm) maneuvering space located between the beds.

In addition, there shall be a clear space under the bed for the use of a personal lift device. The clear space shall be on a long side of the bed adjacent to an accessible aisle. The clear space shall extend horizontally to points not more than

12 inches (305 mm) from each end of the bed, vertically not less than 7 inches (178 mm), and not less than 30 inches (762 mm) deep.

1111B.4.4 Kitchens, kitchenettes or wet bar facilities. When accommodations are provided with kitchens, kitchenettes, wet bar units or similar amenities, they shall be accessible and meet the requirements of Section 1133A. Kitchens shall be provided per the number required to be accessible in conformance with Table 11B-3.

1111B.4.5 Visual alarms, notification devices and telephones for persons with hearing impairments. In addition to those accessible sleeping rooms and suites required by Section 1111B.4.2, additional sleeping rooms and suites shall be provided with the following features as required by Table 11B-4 as follows:

1111B.4.5.1 Visual alarms. Visual alarms shall be provided and shall comply with NFPA 72 and Chapter 9, Sections 907.9.1 and 907.9.2.

1111B.4.5.2 Visual notification devices. Visual notification devices shall also be provided in units, sleeping rooms and suites to alert room occupants of incoming

**TABLE 11B-3
ADDITIONAL ACCESSIBILITY REQUIRED IN GUEST ROOMS OR SUITES***

TOTAL NUMBER OF ROOMS	FULLY ACCESSIBLE ROOMS	PLUS ADDITIONAL ACCESSIBLE ROOMS WITH ROLL-IN SHOWERS
1 to 25	0	1
26 to 50	1	1
51 to 75	3	1
76 to 100	4	1
101 to 150	5	2
151 to 200	6	2
201 to 300	7	3
301 to 400	8	4
401 to 500	9	4 plus 1 for each additional 100 over 400
501 to 1,000	2% of total	4 plus 1 for each additional 100 over 400
1,001 and over	20 plus 1 for each 100 over 1,000	

*Provisions of this chapter are additional modifications to general requirements listed in Section 1114B.1.1.

**TABLE 11B-4
ADDITIONAL ACCESSIBILITY REQUIRED FOR HEARING IMPAIRED IN GUEST ROOMS***

TOTAL NUMBER OF ROOMS	NUMBER OF ROOMS EQUIPPED FOR HEARING IMPAIRED
1 to 25	1
26 to 50	2
51 to 75	3
76 to 100	4
101 to 150	5
151 to 200	6
201 to 300	7
301 to 400	8
401 to 500	9
501 to 1,000	2% of total
1,001 and over	20 plus 1 for each 100 over 1,000

*Provisions of this chapter are additional modifications to general requirements listed in Section 1114B.1.1. For Group I-1 and R-1 occupancies, also see Section 907.9.1.3.

telephone calls and a door knock or bell. Notification devices shall not be connected to visual alarm signal appliances.

1111B.4.5.3 Telephones. Permanently installed telephones shall have volume controls complying with Section 1117B.2.8; an accessible electrical outlet within 48 inches (1219 mm) of a telephone connection shall be provided to facilitate the use of a text telephone.

1111B.4.6 Bathrooms in hotels, motels, inns, dormitories, resorts, homeless shelters, halfway houses, transient group homes and similar places of transient lodging. Required accessible bathrooms for places of transient lodging shall comply with the following provisions:

1. **Doors.** Doors to accessible bathrooms shall comply with Section 1133B.2. Doors shall not swing into the floor space required for any fixture.
2. **Clear floor space.** All fixtures and controls shall be on an accessible route. There must be within the bathroom a clear floor space measuring 30 inches by 60 inches (762 mm by 1524 mm). The clear floor spaces at fixtures and controls, the accessible route and the turning space may overlap.
3. **Water closets.** If a toilet compartment is provided, it shall comply with Section 1115B.3.1 or 1115B.3.2; its water closet shall comply with Section 1115B.4.1 of this code.
4. **Lavatory and mirrors.** If a lavatory and/or mirror is provided, they shall comply with Sections 1115B.4.3 and 1115B.8.1, as applicable.
5. **Controls and dispensers.** If controls, dispensers, receptacles or other types of equipment are provided, then at least one of each shall be on an accessible route and shall comply with Section 1117B.6, Controls and Operating Mechanisms.
6. **Bathing and shower facilities.** If tubs or showers are provided, then at least one accessible tub that complies with Section 1115B.4.5 or at least one accessible shower that complies with Section 1115B.4.4 of this code shall be provided.
7. **Toilet facilities.** Toilet facilities shall comply with Section 1111B.4.6, as modified for hotel, motel and dormitory accommodations.

Hotel and motel bathrooms beyond those specified in Section 1111B.4 shall provide the following features:

1. All bathroom fixtures shall be in a location that allows a person using a wheelchair measuring 30 inches by 48 inches (762 mm by 1219 mm) to touch the wheelchair to any lavatory, urinal, water closet, tub, sauna, shower stall and any other similar sanitary installation, if provided.
2. All bathroom entrance doors shall have a clear opening width of 32 inches (813 mm) and shall be either sliding doors or shall be hung to swing in the direction of egress from the bathroom.

1111B.4.7 Storage areas. Fixed or built-in storage facilities located within accessible sleeping rooms or suites required

by Table 11B-3 shall be accessible in the number and dimensions provided in Section 1125B.

1111B.4.8 Dormitory rooms. Dormitory rooms beyond those specified herein shall comply with the adaptability requirements of Section 1111B.5.

1111B.5 Buildings and complexes containing publicly funded dwelling units.

1111B.5.1 General. Buildings and complexes containing publicly funded dwelling units shall be accessible as required by Chapter 11A, Housing Accessibility, except that scoping requirements for covered multifamily dwellings include one or more publicly funded dwelling units, and are required to comply with Division IV—Accessibility for Existing Buildings, beginning with Section 1134B.

SECTION 1112B Reserved

SECTION 1113B Reserved

SECTION 1114B FACILITY ACCESSIBILITY

When buildings are required to be accessible, buildings and facilities shall be accessible as provided in this section.

1114B.1 Design and construction.

1114B.1.1 General. When accessibility is required by this chapter, it shall be designed and constructed to meet the minimum requirements of the following sections:

Chapter 11B, Accessibility; Division I, New Buildings; Division II, Site Accessibility; Division III, Accessibility for Entrances, Exits and Paths of Travel; and Division IV, Accessibility for Existing Buildings

Entrances—[for HCD 1-AC] Section 1120A.1; [for DSA-AC] Section 1133B.1.1

Doors—[for HCD 1-AC] Sections 1114A.4.4, 1117A.2, 1122A.3.4, 1126A, 1132A; [for DSA-AC] Section 1133B.2

Corridors—[for HCD 1-AC] Section 1120A; [for DSA-AC] Section 1133B.3

Stairways—[for HCD 1-AC] Sections 1115A.6, 1123A; [for DSA-AC] Section 1133B.4

Ramps—[for HCD 1-AC] Sections 1112A, 1114A, 1122A; [for DSA-AC] Section 1133B.5

Aisles—[for DSA-AC] Section 1133B.6

Walks and Sidewalks—[for HCD 1-AC] Section 1113A; [for DSA-AC] Section 1133B.7

Hazards—[for HCD 1-AC] Sections 1116A, 1125A; [for DSA-AC] Section 1133B.8

Elevators—[for HCD 1-AC] Section 3003; [for DSA-AC] Section 1116B

Platform (Wheelchair) Lifts—[for HCD 1-AC] Section 1124A; [for DSA-AC] Section 1116B.2

Alarms—Chapter 9, Sections 907.9.1 and 907.9.2

Bathing and Toilet Facilities—Section 1115B

Signs and Identification—Section 1117B.5

Detectable Warnings—[for DSA-AC] Sections 1121B.3.1 Item 8(a), 1127B.5.7, 1133B.8.5, Part 12—Chapters 12-11A and 12-11B

See also Part 3, California Electrical Code.

1114B.1.2 Accessible route of travel. When a building, or portion of a building, is required to be accessible or adaptable, an accessible route of travel complying with Sections 1102B, 1114B, 1124B, 1133B.3, 1133B.5, 1133B.7 and 1133B.8.6 shall be provided to all portions of the building, to accessible building entrances and between the building and the public way. Except within an individual dwelling unit, an accessible route of travel shall not pass through kitchens, storage rooms, restrooms, closets or other spaces used for similar purposes. At least one accessible route within the boundary of the site shall be provided from public transportation stops, accessible parking and accessible passenger loading zones and public streets or sidewalks to the accessible building entrance they serve. The accessible route shall, to the maximum extent feasible, coincide with

the route for the general public. At least one accessible route shall connect accessible buildings, facilities, elements and spaces that are on the same site. At least one accessible route shall connect accessible building or facility entrances with all accessible spaces and elements and with all accessible dwelling units within the building or facility. An accessible route shall connect at least one accessible entrance of each accessible dwelling unit with those exterior and interior spaces and facilities that serve the accessible dwelling unit.

Where more than one route of travel is provided, all routes shall be accessible.

Exception: Where an elevator is provided for vertical access, only one elevator is required. Where more than one elevator is provided, all elevators shall be accessible. See Section 1114B.1.1 for a list of code sections applicable to accessible routes of travel.

1114B.1.3 Primary entry access. All entrances and all exterior ground-level exits shall be accessible in compliance with Section 1133B.1.1.

1114B.1.4 Signs. See Section 1117B.5.

1114B.1.5 Adaptable dwelling units. See Section 1111B.

1114B.2 Egress and areas of refuge.

**TABLE 1115B-1
SUGGESTED DIMENSIONS FOR CHILDREN'S USE**

The Division of the State Architect—Access Compliance recommends the following dimensions as adequately serving the needs of children in projects under our jurisdiction. These recommendations are based on the federal "Recommendations for Accessibility for Children in Elementary School" and other recognized publications on access for children:

A = Adult Dimensions (age 12 and over)

E = Elementary Dimensions

K = Kindergarten and Preschool Dimensions

DIMENSION	SUGGESTED		
	A (inches)	E (inches)	K (inches)
Toilet centering from wall	18	15	12
Toilet seat height/Dimensions to top of seat	17-19	15	10-12
Grab bar height (side)	33	27	20-22
Toilet paper in front of toilet	12 max	6 max	6 max
Napkin disposal in front of toilet	12 max	12 max	N/A
Dispenser or mirror height	40 max	36 max	32 max
Lavatory/sink top height	34 max	29 max	24 max
Lavatory/sink knee clearance	27 min	24 min	19 min
Urinal lip height	17 max	15 max	13 min
Urinal flush handle height	44 max	37 max	32 max
Drinking fountain bubbler height	36 max	32 max	30 max
Drinking fountain knee clearance	27 min	24 min	22 min
Ramp/stair handrail height	34-38	27	22

For SI: 1 inch = 25.4 mm.

1114B.2.1 General. In buildings or facilities or portions of buildings or facilities required to be accessible, accessible means of egress shall be provided as required by Chapter 10, Section 1007.

1114B.2.2 Alarms/emergency warning systems/accessibility. If emergency warning systems are provided, they shall include both audible alarms and visual alarms complying with NFPA 72 and Chapter 9, Sections 907.9.1 and 907.9.2.

SECTION 1115B BATHING AND TOILET FACILITIES (SANITARY FACILITIES)

1115B.1 General. Bathing and toilet facilities that serve buildings, facilities or portions of buildings or facilities that are required by these standards to be accessible to persons with disabilities, shall be on an accessible route and shall conform to the following requirements.

The accessible fixtures and controls required in this section shall be on an accessible route. An unobstructed turning space complying with Section 1115B.3.1, Item 1, or 1115B.3.2, Item 1, as applicable, shall be provided within an accessible toilet facility. The clear floor spaces at fixtures and controls, the accessible route and the turning space may overlap.

See Section 1111B.4.6 and Chapter 11A for bathrooms in residential occupancies.

Exception: In existing buildings or facilities, when the enforcing agency determines that compliance with any building standard under this section would create an unreasonable hardship, an exception to such standard may be granted when equivalent facilitation is provided. When equivalent facilitation is used, the following criteria shall apply:

1. All sanitary facilities are not required to comply with these building standards when the enforcing agency determines that sanitary facilities are accessible to and usable by persons with disabilities within a reasonable distance of accessible areas.
2. When existing sanitary facilities are not being altered to provide accessibility, signage complying with Sections 1117B.5.1, Items 2 and 3, and 1117B.5.8.1 shall be provided at such inaccessible facilities indicating the location of the nearest accessible sanitary facility.

1115B.1.1 Separate and unisex facilities. Where separate facilities are provided for persons of each sex, these facilities shall be accessible to persons with disabilities. Where unisex facilities are provided, these facilities shall be accessible to persons with disabilities.

1115B.1.2 Where used by children. Where facilities are to be used solely by small children, the specific heights and clearances may be adjusted to meet their accessibility needs. See Table 1115B-1 for suggested mounting heights and clearances.

1115B.2 Bathing and shower facilities. Where facilities for bathing are provided for the public, clients or employees, including showers or bathtubs, at least one shower or bathtub and support facilities such as lockers, and not less than 1 per-

cent of all facilities, shall be accessible and conform to the following standards:

1. **Shower areas.** Showers in all occupancies shall be finished as specified in Section 1115B.3.1, Item 6 to a height of not less than 70 inches (1778 mm) above the drain inlet. Materials other than structural elements used in such walls shall be of a type which is not adversely affected by moisture.
2. **Doors and panels.** Doors and panels of shower and bathtub enclosures shall be substantially constructed from approved, shatter-resistant materials. Hinged shower doors shall open outward.
3. **Glazing for shower and bathtub enclosures.** Glazing used in doors and panels of shower and bathtub enclosures shall be fully tempered, laminated safety glass or approved plastic. When glass is used, it shall have minimum thickness of not less than $1/8$ inch (3.2 mm) when fully tempered, or $1/4$ inch (6.4 mm) when laminated, and shall pass the test requirements of Section 2406.
4. **Plastics.** Plastics used in doors and panels of showers and bathtub enclosures shall be of a shatter-resistant type.

1115B.3 Toilet facilities.

1115B.3.1 Multiple-accommodation toilet facilities. Multiple-accommodation toilet facilities shall have the following:

1. **Wheelchair clearance.** A clear space measured from the floor to a height of 27 inches (686 mm) above the floor, within the sanitary facility room, of sufficient size to inscribe a circle with a diameter not less than 60 inches (1524 mm) in size. Other than the door to the accessible water closet compartment, a door, in any position, may encroach into this space by not more than 12 inches (305 mm).
2. **Clear floor space at fixtures.** Doors shall not swing into the clear floor space required for any fixture.

Exception: An in-swinging, side-opening door to an accessible water closet compartment shall comply with Figure 11B-1B.
3. **Accessible fixtures.** Provide a minimum of one accessible water closet in compliance with Section 1115B.4.1. At least 5 percent of lavatories, but not less than one lavatory, shall be accessible in compliance with Section 1115B.4.3.
4. **Accessible water closet compartment.** Accessible water closet compartments shall comply with the following:
 - 4.1. The compartment shall be a minimum of 60 inches (1524 mm) wide.
 - 4.2. If the compartment has a side-opening door, a minimum 60-inches-wide (1524 mm) and 60 inches-deep (1524 mm) clear floor space shall be provided in front of the water closet.
 - 4.3. If the compartment has an end-opening door (facing the water closet), a minimum 60-inches-wide (1524 mm) and 48-inches-deep (1219 mm) clear floor space shall be

provided in front of the water closet. The door shall be located in front of the clear floor space and diagonal to the water closet, with a maximum stile width of 4 inches (102 mm).

- 4.4. The water closet compartment shall be equipped with a door that has an automatic-closing device, and shall have a clear, unobstructed opening width of 32 inches (813 mm) when located at the end and 34 inches (864 mm) when located at the side with the door positioned at an angle of 90 degrees from its closed position.
- 4.5. The inside and outside of the compartment door shall be equipped with a loop or U-shaped handle immediately below the latch. The latch shall be flip-over style, sliding or other hardware not requiring the user to grasp or twist. Except for door-opening widths and door swings, a clear, unobstructed access of not less than 44 inches (1118 mm) shall be provided to water closet compartments designed for use by persons with disabilities. Maneuvering space at the compartment door shall comply with Sections 1133B.2.4.2 and 1133B.2.4.3, and in no case shall the space immediately outside of the water closet compartment door be less than 48 inches (1219 mm) as measured perpendicular to the compartment door in its closed position.
5. **Large toilet rooms.** Where six or more compartments are provided within a multiple-accommodation toilet room, at least one compartment shall comply with Items 3 and 4 above, and at least one additional ambulatory accessible compartment shall be 36 inches (914 mm) wide with an outward swinging self-closing door and parallel grab bars complying with Section 1115B.4.1, Item 3.
6. **Interior surfaces.** In other than dwelling units, toilet room floors shall have a smooth, hard, nonabsorbent surface such as Portland cement, concrete, ceramic tile or other approved material which extends upward onto the walls at least 5 inches (127 mm). Walls within water closet compartments and walls within 24 inches (610 mm) of the front and sides of urinals shall be similarly finished to a height of 48 inches (1219 mm) and, except for structural elements, the materials used in such walls shall be a type which is not adversely affected by moisture.

1115B.3.2 Single-accommodation toilet facilities. Single-accommodation toilet facilities shall have the following:

1. **Wheelchair clearance.** There shall be sufficient space in the toilet room for a wheelchair measuring 30 inches (762 mm) wide by 48 inches (1219 mm) long to enter the room and permit the door to close. There shall be in the room a clear floor space of at least 60 inches (1524 mm) in diameter, or a T-shaped space complying with Figure 11B-12 (a) and (b). No door shall encroach into this space for more than 12 inches (305 mm). See Figure 11B-1A.
 2. **Clear floor space at fixtures.** Doors shall not swing into the clear floor space required for any fixture.
 3. **Accessible water closet.** Provide one accessible water closet in compliance with Section 1115B.4.1.
 4. **Accessible route.** All doors, fixtures and controls shall be on an accessible route. The minimum clear width of an accessible route shall be 36 inches (914 mm) except at doors (see Section 1133B.2). If a person in a wheelchair must make a turn around an obstruction, the minimum clear width of the accessible route shall be as shown in Figure 11B-5E. See also Figure 11B-1A.
 5. **Interior surfaces.** In other than dwelling units, toilet room floors shall have a smooth, hard, nonabsorbent surface such as Portland cement, concrete, ceramic tile or other approved material which extends upward onto the walls at least 5 inches (127 mm). Walls within water closet compartments and walls within 24 inches (610 mm) of the front and sides of urinals shall be similarly finished to a height of 48 inches (1219 mm) and, except for structural elements, the materials used in such walls shall be a type which is not adversely affected by moisture.
 6. **Accessible lavatory.** Provide one accessible lavatory in compliance with Section 1115B.4.3.
 7. **Privacy latch.** The entrance door shall contain a privacy latch which complies with Section 1117B.6, Controls and Operating Mechanisms.
- For bathrooms serving residential occupancies, see Section 1111B.4.6 and Chapter 11A.
- Exception:** In an existing building, a single-accommodation toilet facility may have the water closet fixture located in an area which provides a clear space of not less than 36 inches (914 mm) wide by 48 inches (1219 mm) long in front of the water closet.

1115B.4 Accessible fixtures.

1115B.4.1 Accessible water closets. Water closets required to be accessible shall comply with this subsection:

1. The centerline of the water closet fixture shall be 18 inches (457 mm) from the side wall or partition. On the other side of the water closet, provide a minimum of 28 inches (711 mm) wide clear floor space if the water closet is adjacent to a fixture or a minimum of 32 inches (813 mm) wide clear floor space if the water closet is adjacent to a wall or partition. This clear floor space shall extend from the rear wall to the front of the water closet.
2. A minimum 60 inches (1524 mm) wide and 48 inches (1219 mm) deep clear floor space shall be provided in front of the water closet.
3. Grab bars for water closets not located within a compartment shall comply with Section 1115B.7 and shall be provided on the side wall closest to the water closet and on the rear wall. Grab bars for water closets

ets located within an accessible compartment shall comply with Section 1115B.7 and shall be provided on the side wall closest to the water closet and on the rear wall. Grab bars for water closets located within ambulatory accessible compartments shall comply with Section 1115B.7 and shall be provided on both sides of the compartment.

Grab bars shall not project more than 3 inches (76 mm) into the required clear floor space.

- 3.1. **Side wall.** The side grab bar shall be 42 inches (1067 mm) long minimum, located 12 inches (305 mm) maximum from the rear wall and extend 54 inches (1372 mm) minimum from the rear wall with the front end positioned 24 inches (610 mm) minimum in front of the water closet. The side grab bar shall be securely attached and centered 33 inches (838 mm) above and parallel to the floor.
- 3.2. **Rear wall.** The rear grab bar shall be 36 inches (914 mm) long minimum and extend from the centerline of the water closet 12 inches (305 mm) minimum on one side and 24 inches (610 mm) minimum on the other side. The rear grab bar shall be securely attached and centered 33 inches (838 mm) above and parallel to the floor; except that where a tank-type toilet is used which obstructs placement at 33 inches (838 mm), the grab bar may be as high as 36 inches (914 mm) and the space between the grab bar and the top of the tank shall be 1½ inches (38 mm) minimum.
4. The height of accessible water closets shall be a minimum of 17 inches (432 mm) and a maximum of 19 inches (483 mm) measured to the top of a maximum 2-inch (51 mm) high toilet seat.

Exception: A 3-inch (76 mm) high seat shall be permitted only in alterations where the existing fixture is less than 15 inches (381 mm) high.

5. Controls shall be operable with one hand and shall not require tight grasping, pinching or twisting. Controls for the flush valves shall be mounted on the wide side of toilet areas, no more than 44 inches (1118 mm) above the floor. The force required to activate controls shall be no greater than 5 pounds-force (lbf) (22.2 N).
6. See Section 1134A.7 for additional requirements for water closets in publicly funded housing and all non-residential occupancies.
7. Automatic spring to lifted position seats are not allowed.

1115B.4.2 Accessible urinals. Urinals required to be accessible shall comply with this subsection.

1. Urinals shall be floor mounted, stall-type or wall hung. Where one or more wall-hung urinals are provided, at least one with an elongated rim projecting a minimum of 14 inches (356 mm) from the wall and a maximum of 17 inches (432 mm) from the wall and a

maximum of 17 inches (432 mm) above the floor shall be provided.

2. Flush controls shall be operable with one hand and shall not require tight grasping, pinching or twisting of the wrist and shall be mounted no more than 44 inches (1118 mm) above the floor. The force required to activate controls shall be no greater than 5 lbf (22.2 N). Electronic automatic flushing controls are acceptable and preferable.
3. Where urinals are provided, at least one shall have a clear floor space 30 inches by 48 inches (762 mm by 1219 mm) in front of the urinal to allow forward approach. This clear space shall comply with Section 1118B.4.

1115B.4.3 Accessible lavatories. Lavatories required to be accessible shall comply with this subsection. The requirements of this subsection shall apply to lavatory fixtures, vanities and built-in lavatories.

1. Faucet controls and operating mechanisms shall be operable with one hand in accordance with this chapter and shall not require tight grasping, pinching or twisting of the wrist. The force required to activate controls shall be no greater than 5 lbf (22.2 N). Lever-operated, push-type and electronically controlled mechanisms (preferable) are examples of acceptable designs. Self-closing valves are allowed if the faucet remains open for at least 10 seconds.
2. Lavatories, when located adjacent to a side wall or partition, shall be a minimum of 18 inches (457 mm) to the centerline of the fixture. All lavatories that are designated to be accessible shall be a minimum 17 inches (432 mm) in horizontal depth and mounted with the rim or counter edge no higher than 34 inches (864 mm) above the finished floor and with vertical clearance measured from the bottom of the apron or the outside bottom edge of the lavatory of 29 inches (737 mm) reducing to 27 inches (686 mm) at a point located 8 inches (203 mm) back from the front edge. In addition, a minimum 9-inch-high (230 mm) toe clearance must be provided extending back toward the wall to a distance no more than 6 inches (150 mm) from the back wall. The toe clearance space must be free of equipment or obstructions.
3. A clear floor space 30 inches by 48 inches (762 mm by 1219 mm) complying with Section 1118B.4 shall be provided in front of a lavatory to allow forward approach. Such clear floor space shall adjoin or overlap an accessible route and shall extend a maximum of 19 inches (483 mm) into knee and toe space underneath the lavatory. See Figure 11B-1D, Knee Clearance.
4. Hot water and drainpipes accessible under lavatories shall be insulated or otherwise covered. There shall be no sharp or abrasive surfaces under lavatories.

1115B.4.4 Accessible showers. Showers required to be accessible shall comply with this subsection:

- 1115B.4.4.1 Size and clearances.** Accessible showers shall comply with one of the following:

1. Roll-in shower 60 inches (1524 mm) minimum in width between wall surfaces and 30 inches (762 mm) minimum in depth with a full opening width on the long side. Shower compartment size and clear floor space shall comply with Figure 11B-2A.
2. Alternate roll-in shower 60 inches (1524 mm) minimum in width between wall surfaces and 36 inches (914 mm) in depth with an entrance opening width of 36 inches (914 mm) minimum. Shower compartment size and clear floor space shall comply with Figure 11B-2B.
3. Alternate roll-in shower 60 inches (1524 mm) minimum in width between wall surfaces and 36 inches (914 mm) minimum in depth as long as the entrance opening width is a minimum 36 inches (914 mm). Shower compartment size and clear floor space shall comply with Figure 11B-2C.

1115B.4.4.2 Thresholds. Thresholds in roll-in type showers shall be $\frac{1}{2}$ inch (12.7 mm) high maximum and shall comply with Section 1124B.2.

1115B.4.4.3 Orientation. Where, within the same functional area, two or more accessible showers are provided, there shall be at least one shower constructed opposite hand from the other or others (that is, one left-hand controls versus right-hand controls).

1115B.4.4.4 Water controls. Water controls shall be of a single-lever design, operable with one hand, and shall not require tight grasping, pinching or twisting of the wrist. The force required to activate controls shall be no greater than 5 lbf (22.2N). The centerline of the controls shall be located 39 inches (991 mm) to 41 inches (1041 mm) above the shower floor.

1. Controls in a 60-inch (1524 mm) minimum by 30-inch (762 mm) minimum roll-in shower shall be located on the back wall of the compartment adjacent to the seat and the centerline of the controls shall be within a range of no less than 19 inches (457 mm) and no more than 27 inches (610 mm) from the seat wall as shown in Figure 11B-2A.
2. Controls in a 60-inch (1524 mm) minimum by 36-inch (914 mm) alternate roll-in shower shall be located on the side wall of the compartment adjacent to the seat and the centerline of the controls shall be within a range of no less than 19 inches (457 mm) and no more than 27 inches (610 mm) from the seat wall as shown in Figure 11B-2B.
3. Controls in a 60-inch (1524 mm) minimum by 36-inch (914 mm) minimum alternate roll-in shower with optional enclosure shall be located on the back wall of the compartment adjacent to the seat and the centerline of the controls shall be within a range of no less than 19 inches (457 mm) and no more than 27 inches (610 mm) from the seat wall as shown in Figure 11B-2C.

1115B.4.4.5 Hand-held sprayer unit. A flexible hand-held sprayer unit with a hose at least 60 inches

(1524 mm) long that can be used both as a fixed shower head and as a hand-held shower shall be provided. This unit shall be mounted such that the top of the mounting bracket is at a maximum height of 48 inches (1219 mm) above the shower floor.

1. The hand-held sprayer unit in a 60-inch (1524 mm) minimum by 30-inch (762 mm) minimum roll-in shower shall be located on the back wall of the compartment adjacent to the seat and the centerline of the unit shall be no more than 27 inches (610 mm) from the seat wall as shown in Figure 11B-2A.
2. The hand-held sprayer unit in a 60-inch (1524 mm) minimum by 36-inch (914 mm) alternate roll-in shower shall be located on the side wall of the compartment adjacent to the seat and the centerline of the unit shall be 18 inches (457 mm) from the seat wall as shown in Figure 11B-2B.
3. The hand-held sprayer unit in a 60-inch (1524 mm) minimum by 36-inch (914 mm) minimum alternate roll-in shower with optional enclosure shall be located on the back wall of the compartment adjacent to the seat and the centerline of the unit shall be no more than 27 inches (610 mm) from the seat wall as shown in Figure 11B-2C.

1115B.4.4.6 Sprayer unit alternative. Except within guest rooms and suites in hotels, motels and similar transient lodging establishments, where accessible shower facilities are provided in areas subject to excessive vandalism, in lieu of providing the fixed flexible hose, two wall-mounted shower heads shall be installed. Each shower head shall be installed so that it can be operated independently of the other and shall have swivel angle adjustments, both vertically and horizontally. One shower head shall be located at a height of 48 inches (1219 mm) above the floor.

1115B.4.4.7 Floor slope. The maximum slope of the floor shall be one unit vertical in 50 units horizontal (2-percent slope) in any direction. Where drains are provided, grate openings shall be a maximum of $\frac{1}{4}$ inch (6.4 mm) and located flush with the floor surface.

1115B.4.4.8 Shower accessories. Shower accessories shall include:

1. A folding seat mounted 18 inches (457 mm) above the floor, and with a minimum space of 1 inch (25 mm) and maximum space of $1\frac{1}{2}$ inches (38 mm) allowed between the edge of the seat and any wall. When folded, the seat shall not extend more than 6 inches (152 mm) from the mounting wall. The seat dimensions and mounting position shall comply with Figures 11B-2A, 11B-2B, 11B-2C and 11B-2D. The structural strength of seats and their attachments shall comply with Section 1115B.7.2.
2. Grab bars located on walls adjacent to and opposite the seat. Grab bars shall also comply with the diameter, loading and projection requirements of Section 1115B.7. Grab bars shall be mounted be-

tween a minimum of 33 inches (838 mm) and a maximum of 36 inches (914 mm) above the shower floor with an L-shaped grab bar mounted on walls opposite and adjacent to the front edge of the seat, but not extended to include that portion of wall over the seat. See Figure 11B-2A or 11B-2B.

1115B.4.4.9 Soap dish. When a soap dish is provided, it shall be located on the control wall at a maximum height of 40 inches (1016 mm) above the shower floor, and within reach limits from the seat.

1115B.4.4.10 Enclosures. Enclosures, when provided for shower compartments, shall not obstruct controls or obstruct transfer from wheelchairs onto shower seats.

See Figures 11B-2A, 11B-2B, 11B-2C and 11B-2D.

1115B.4.5 Accessible bathtubs. Bathtubs required to be accessible shall comply with this subsection.

1. **Floor space.** Clear floor space at bathtubs shall be as shown in Figure 11B-8.
2. **Seat.** An in-tub seat or a seat at the head end of the tub shall be provided as shown in Figures 11B-8 and 11B-9. The structural strength of seats and their attachments shall comply with Section 1115B.7.2. Seats shall be mounted securely and shall not slip during use.
3. **Grab bars.** Grab bars complying with Section 1115B.7 shall be provided as shown in Figure 11B-9.
4. **Controls.** Faucets and other controls shall be located as shown in Figure 11B-9. They shall be operable with one hand and shall not require tight grasping, pinching or twisting of the wrist. The force required to activate controls shall be no greater than 5 lbf (22.2 N).
5. **Shower unit.** A shower spray unit with a hose at least 60 inches (1524 mm) long that can be used both as a fixed shower head and as a hand-held shower shall be provided.
6. **Bathtub enclosures.** If provided, enclosures for bathtubs shall not obstruct controls or transfer from wheelchairs onto bathtub seats or into tubs. Enclosures on bathtubs shall not have tracks mounted on their rims.

1115B.4.6 Accessible drinking fountains. Where drinking fountains are provided, they shall comply with this section:

1. **General.** Where only one drinking fountain area is provided on a floor, there shall be a drinking fountain that is accessible to individuals who use wheelchairs in accordance with this section and one accessible to those who have difficulty bending or stooping. This can be accommodated by the use of "hi-low" fountains, or by such other means as would achieve the required accessibility for each group on each floor.

Where more than one drinking fountain is provided on a floor, 50 percent of those provided shall comply with Items 1, 2, 4 and 5 of this section and shall be on an accessible route complying with Section

1114B.1.2. All drinking fountains shall comply with Item 3 of this section.

2. **Clearances.** Wall- and post-mounted cantilevered drinking fountains shall be a minimum of 18 inches (457 mm) and a maximum of 19 inches (483 mm) in depth and shall have a clear knee space between the bottom of the apron and the floor or ground not less than 27 inches (686 mm) in height, 30 inches (762 mm) in width, and 8 inches (203 mm) in depth, the depth measurements being taken from the front edge of the fountain back toward the wall or mounting post. The knee clearance space must be free of equipment or obstructions. Additionally, there shall be toe clearance of 9 inches (229 mm) in height above the floor and 17 inches (432 mm) in depth from the front edge of the fountain. The toe clearance space must be free of equipment or obstructions. A clear floor space at least 30 inches (762 mm) by 48 inches (1219 mm) complying with Section 1118B.4 shall be provided in front of the drinking fountain to allow forward approach. A side approach drinking fountain is not acceptable.
3. **Alcoves.** All drinking fountains shall be located completely within alcoves or otherwise positioned so as not to encroach into pedestrian ways. The alcove in which the drinking fountain is located shall not be less than 32 inches (813 mm) in width and 18 inches (457 mm) in depth. See Figure 11B-3 of this code. Additionally, alcoves shall comply with Section 1118B.4, Item 2. Protruding objects located in alcoves or otherwise positioned so as to limit encroachment into pedestrian ways are permitted to project 4 inches (102 mm) into walks, halls, corridors, passageways or aisles.

Exception: When the enforcing agency determines that it would create an unreasonable hardship to locate the drinking fountain in an alcove, the drinking fountain may project into the path of travel, and the path of travel shall be identifiable to the blind as follows. Wing walls shall be provided on each side of the drinking fountain. The wing walls shall project out from the supporting wall at least as far as the drinking fountain to within 6 inches (152 mm) of the surface of the path of travel. There shall also be a minimum of 32 inches (813 mm) clear between the wing walls. Additionally, maneuvering clearances shall comply with Section 1118B.4, Item 2. The drinking fountain and wing walls shall comply with Section 1133B.8.6.

4. The bubbler shall be activated by a manually operated system complying with Section 1117B.6, Item 4 that is front mounted or side mounted and located within 6 inches (152 mm) of the front edge of the fountain or an electronically controlled device (preferably). The bubbler outlet orifice shall be located within 6 inches (152 mm) of the front edge of the drinking fountain and within 36 inches (914 mm) of the floor. The water stream from the bubbler shall be substan-

tially parallel to the front edge of the drinking fountain.

5. The spout shall provide a flow of water at least 4 inches (102 mm) high so as to allow the insertion of a cup or glass under the flow of water. On an accessible drinking fountain with a round or oval bowl, the spout must be positioned so the flow of water is within 3 inches (75 mm) of the front edge of the fountain.

1115B.4.7 Accessible sinks.

1. **Accessible kitchen sinks.** A clear floor space at least 30 inches by 48 inches (762 mm by 1219 mm) complying with Section 1118B.4 shall be provided in front of a sink to allow forward approach. The clear floor space shall be on an accessible route and shall extend a maximum of 19 inches (485 mm) underneath the sink (see Figure 11B-1D).

Each accessible sink shall be a maximum of 6½ inches (165 mm) deep. Sinks shall be mounted with the counter or rim no higher than 34 inches (865 mm) above the finish floor. Knee clearance that is at least 27 inches (685 mm) high, 30 inches (762 mm) wide and 19 inches (485 mm) deep shall be provided underneath sinks. Hot water and drain pipes exposed under sinks shall be insulated or otherwise configured so as to protect against contact. There shall be no sharp or abrasive surfaces under sinks.

Faucet controls and operating mechanisms shall be operable with one hand and shall not require tight grasping, pinching or twisting of the wrist. The force required to activate controls shall be not greater than 5 lbf (22.2 N). Lever-operated, push-type and electronically controlled mechanisms are examples of acceptable designs. Self-closing valves are allowed if the faucet remains open for at least 10 seconds.

2. **Noncommercial kitchen and counter bar sinks.** A clear floor space at least 30 inches by 48 inches (762 mm by 1219 mm) complying with Section 1118B.4 shall be provided in front of a sink to allow forward approach. The clear floor space shall be on an accessible route and shall extend a maximum of 19 inches (485 mm) underneath the sink (see Figure 11B-1D).

Each accessible sink shall be a maximum of 6½ inches (165 mm) deep. Sinks shall be mounted with the counter or rim no higher than 34 inches (865 mm) above the finish floor. Knee clearance that is at least 27 inches (685 mm) high, 30 inches (762 mm) wide and 19 inches (485 mm) deep shall be provided underneath sinks. Hot water and drain pipes exposed under sinks shall be insulated or otherwise configured so as to protect against contact. There shall be no sharp or abrasive surfaces under sinks.

Kitchen and counter bar sinks located in common use areas shall have faucet controls and operating mechanisms operable with one hand in accordance with this chapter and shall not require tight grasping, pinching or twisting of the wrist. The force required to activate controls shall be not greater than 5 lbf (22.2 N). Lever-operated, push-type and electronically

controlled mechanisms are examples of acceptable designs.

1115B.5 Passageways. Passageways leading to sanitary facilities shall have a clear access. All doorways leading to such sanitary facilities shall comply with Section 1133B.2, Doors. Doors shall not swing into the clear floor space required for any fixture. Accessible fixtures and controls shall be on an accessible route.

1115B.6 Identification symbols. Doorways leading to sanitary facilities shall be identified by a geometric symbol in compliance with this section. Geometric symbols shall be centered horizontally on the door at a height of 60 inches (1524 mm) above the finish floor or ground surface measured to the center of the symbol. Edges of signs shall be rounded, chamfered or eased. Corners of signs shall have a minimum radius of 1/8 inch (3.2 mm). See Section 1117B.5.1, Item 1 for additional signage requirements applicable to sanitary facilities.

1115B.6.1 Men's sanitary facilities shall be identified by an equilateral triangle, 1/4 inch (6.4 mm) thick with edges 12 inches (305 mm) long and a vertex pointing upward. The triangle symbol shall contrast with the door, either light on a dark background or dark on a light background.

1115B.6.2 Women's sanitary facilities shall be identified by a circle, 1/4 inch (6.4 mm) thick and 12 inches (305 mm) in diameter. The circle symbol shall contrast with the door, either light on a dark background or dark on a light background.

1115B.6.3 Unisex sanitary facilities shall be identified by a circle, 1/4 inch (6.4 mm) thick and 12 inches (305 mm) in diameter with a 1/4 inch (6.4 mm) thick triangle superimposed on the circle and within the 12-inch (305 mm) diameter. The triangle symbol shall contrast with the circle symbol, either light on a dark background or dark on a light background. The circle symbol shall contrast with the door, either light on a dark background or dark on a light background.

1115B.7 Grab bars, tub and shower seats. All grab bars, tub and shower seats shall comply with this section.

1115B.7.1 Diameter or width. The diameter or width of the gripping surfaces of a grab bar shall be 1¼ inches to 1½ inches (32 mm to 38 mm) or the shape shall provide an equivalent gripping surface. If grab bars are mounted adjacent to a wall, the space between the wall and the grab bars shall be 1½ inches (38 mm). See Figure 11B-1C.

1115B.7.2 Structural strength. The structural strength of grab bars, tub and shower seats, fasteners and mounting devices shall meet the following specifications:

1. Bending stress in a grab bar or seat induced by the maximum bending moment from the application of a 250-pound (1112 N) point load shall be less than the allowable stress for the material of the grab bar or seat.
2. Shear stress induced in a grab bar or seat by the application of a 250-pound (1112 N) point load shall be less than the allowable shear stress for the material of the grab bar or seat, and its mounting bracket or other support is considered to be fully restrained, then di-

rect and torsional shear stresses shall not exceed the allowable shear stress.

3. Shear force induced in a fastener or mounting device from the application of a 250-pound (1112 N) point load shall be less than the allowable lateral load of either the fastener or mounting device or the supporting structure, whichever is the smaller allowable load.
4. Tensile force induced in a fastener by a direct tension force of a 250-pound (1112 N) point load, plus the maximum moment from the application of a 250-pound (1112 N) point load, shall be less than the allowable withdrawal load between the fastener and supporting structure.
5. Grab bars shall not rotate within their fittings.

1115B.7.3 Surface. A grab bar and any wall or other surface adjacent to it shall be free of any sharp or abrasive elements. Edges shall have a minimum radius of $1/8$ inch (3.2 mm).

1115B.8 Accessories.

1115B.8.1 Mirrors.

1115B.8.1.1 All mirrors located above accessible lavatories or countertops shall be installed with the bottom edge of the reflecting surface 40 inches (1016 mm) maximum above the finish floor or ground.

1115B.8.1.2 When mirrors are provided at locations other than above lavatories or countertops, at least one shall be installed with the bottom edge of the reflecting surface 35 inches (890 mm) maximum above the finish floor or ground.

1115B.8.1.3 Mirrors in fitting and dressing areas shall comply with Section 1117B.8.

1115B.8.2 Medicine cabinets. If medicine cabinets are provided, at least one shall be located with a usable shelf no higher than 44 inches (1118 mm) above the floor. A clear floor space 30 inches by 48 inches (762 mm by 1219 mm) complying with Section 1118B.4 shall be provided in front of a medicine cabinet to allow a forward or parallel approach.

1115B.8.3 Towel, sanitary napkins, waste receptacles, dispensers and controls. Where towel, sanitary napkins, waste receptacles, dispensers, other equipment and controls are provided, at least one of each type shall be located on an accessible route, with all operable parts, including coin slots, within 40 inches (1016 mm) from the finished floor and shall comply with Section 1117B.6, Controls and Operating Mechanisms.

1115B.8.4 Toilet tissue dispensers. Toilet tissue dispensers shall be located on the wall within 12 inches (305 mm) of the front edge of the toilet seat, mounted below the grab bar, at a minimum height of 19 inches (485 mm), and 36 inches (914 mm) maximum to the far edge from the rear wall. Dispensers that control delivery or that do not permit continuous paper flow shall not be used. See Figure 11B-1A.

1115B.8.5 Lockers. Where lockers are provided for the public, clients, employees, members or participants, at least one locker and not less than 1 percent of all lockers shall be

made accessible to persons with disabilities. A path of travel not less than 36 inches (914 mm) in clear width shall be provided to these lockers.

SECTION 1116B ELEVATORS AND PLATFORM (WHEELCHAIR) LIFTS

1116B.1 Elevators. Passenger elevators shall be accessible. Elevators required to be accessible shall be designed and constructed to comply with this section and with ASME A17.1, Safety Code for Elevators and Escalators.

1116B.1.1 General. Size of cab and control locations and requirements for accommodation of persons with disabilities.

In buildings two or more stories in height, served by an elevator, or a building served by an elevator required by Chapter 11B, or a building served by an elevator required for accessibility by Section 109.1, if more than one passenger elevator is provided, each full passenger elevator shall comply with this chapter.

Exceptions:

1. In existing buildings, when the enforcing agency determines that compliance with any regulation under this section would create an unreasonable hardship, an exception to such regulation shall be granted when equivalent facilitation is provided.
2. In existing buildings, where existing shaft configuration or technical infeasibility prohibits strict compliance with Section 1116B.1.8, the minimum car plan dimensions may be reduced by the minimum amount necessary, but in no case shall the inside car area be smaller than 48 inches (1219 mm) by 48 inches (1219 mm).
3. In existing buildings, equivalent facilitation may be provided with an elevator car of different dimensions where it can be demonstrated that a person using a wheelchair can enter and operate the elevator and when all other elements required to be accessible comply with the applicable provisions of Section 1116B.
4. These provisions shall not apply to existing buildings when legal or physical constraints will not allow compliance with these regulations or equivalent facilitation without creating an unreasonable hardship. See Section 109.1.

1116B.1.2 Operation and leveling. The elevator shall be automatic and provided with a self-leveling feature that will automatically bring the car to the floor landings within a tolerance of plus or minus $1/2$ inch (12.7 mm) under normal loading and unloading conditions. This self-leveling shall, within its zone, be entirely automatic and independent of the operating device and shall correct the overtravel or undertravel. The car shall also be maintained approximately level with the landing, irrespective of load.

The clearance between the car platform sill and the edge of the hoistway landing shall be no greater than 1¹/₄ inches (32 mm).

1116B.1.3 Door operation. Power-operated horizontally sliding car and hoistway doors opened and closed by automatic means shall be provided.

1116B.1.4 Door size. Minimum clear width for elevator doors shall be 36 inches (914 mm).

1116B.1.5 Door protective and reopening device. Doors closed by automatic means shall be provided with a door-reopening device that will function to stop and reopen a car door and adjacent hoistway door in case the car door is obstructed while closing.

This reopening device shall also be capable of sensing an object or person in the path of a closing door without requiring contact for activation at a nominal 5 inches and 29 inches (127 mm and 737 mm) above the floor.

Door-reopening devices shall remain effective for a period of not less than 20 seconds.

After such an interval, the doors may close in accordance with the requirements of ASME A17.1.

1116B.1.6 Hall call. The minimum acceptable time from notification that a car is answering a call (lantern and audible signal) until the doors of the car start to close shall be calculated by the following equation:

$$T = D / (1.5 \text{ ft/s}) \text{ or } T = D / (455 \text{ mm/s})$$

Where T is the total time in seconds and D is the distance from a point in the lobby or landing area 60 inches (1524 mm) directly in front of the farthest call button controlling that car to the centerline of its hoistway door (see Figure 11B-40D). For cars with in-car lanterns, T begins when the lantern is visible from the vicinity of hall call buttons and an audible signal is sounded. The minimum acceptable notification time shall be 5 seconds.

1116B.1.7 Car call. The minimum acceptable time for doors to remain fully open shall not be less than 5 seconds.

1116B.1.8 Car inside. The car inside shall allow for the turning of a wheelchair. The minimum clear distance between walls or between wall and door, excluding return panels, shall not be less than 80 inches by 54 inches (2032 mm by 1372 mm) for center opening doors, and 68 inches by 54 inches (1727 mm by 1372 mm) for side-slide opening doors. See Figure 11B-40A. Minimum distance from wall to return panel shall not be less than 51 inches (1295 mm). Elevator floor surfaces shall comply with Section 1124B — Ground and Floor Surfaces.

The centerline of elevator floor buttons shall be no higher than 54 inches (1372 mm) above the finish floor for side approach and 48 inches (1219 mm) for front approach. Emergency controls, including the emergency stop and alarm, shall be grouped in or adjacent to the bottom of the panel and shall be no lower than 2 feet 11 inches (889 mm) from the floor.

For multiple controls only, one set must comply with these height requirements. Floor buttons shall be provided with

visual indicators to show when each call is registered. The visual indicators shall be extinguished when each call is answered.

Emergency two-way communication systems between the elevator and a point outside the hoistway shall comply with ASME A17.1. The emergency telephone handset shall be positioned no higher than 4 feet (1219 mm) above the floor, and the handset cord shall be a minimum of 2 feet 5 inches (737 mm) in length. It shall be identified by a raised telephone symbol and corresponding Braille lettering complying with Section 1117B.5.1, Item 1, and located adjacent to the device. If the telephone system is located in a closed compartment, the compartment door hardware shall be lever type conforming to the provisions of Section 1008.1.8, Type of Lock or Latch. Emergency intercommunication shall not require voice communication.

Where possible, a 48-inch (1219 mm) maximum height for elevator floor buttons is preferred.

Controls shall be located on a front wall if cars have center opening doors, and at the side wall or at the front wall next to the door if cars have side opening doors. See Figure 11B-40A.

1116B.1.9 Car controls. Identification for the visually impaired shall be as follows:

Passenger elevator car controls shall have a minimum dimension of ³/₄ inch (19.1 mm) and shall be raised ¹/₈ inch (3.2 mm) plus or minus ¹/₃₂ inch (0.8 mm) above the surrounding surface.

Control buttons shall be illuminated, shall have square shoulders and shall be activated by a mechanical motion that is detectable.

All control buttons shall be designated by ⁵/₈ inch (15.9 mm) minimum raised characters and standard raised symbols that conform to Sections 1117B.5.2, 1117B.5.3, 1117B.5.5 and 1117B.5.7 immediately to the left of the control button. Contracted (Grade 2) Braille that conforms to Section 1117B.5.6 shall be located immediately below the character or symbol. A minimum clear space of ³/₈ inch (9.5 mm) or other suitable means of separation shall be provided between rows of control buttons. See Figure 11B-40B.

The raised characters and symbols shall be white on a black background.

Controls and emergency equipment identified by raised symbols shall include, but not be limited to, "door open," "door close," "alarm bell," "emergency stop" and "telephone." The call button for the main entry floor shall be designated by a raised star at the left of the floor designation.

In elevator cars, a visual car position indicator shall be provided above the car control panel or over the door to show the position of the elevator in the hoistway. As the car passes or stops at a floor served by the elevators, the corresponding numerals shall illuminate, and an audible signal shall sound. Numerals shall be a minimum of ¹/₂ inch (13 mm) high. The audible signal shall be no less than 20 decibels with a frequency no higher than 1,500 Hz. An auto-

matic verbal announcement of the floor number at which a car stops or which a car passes may be substituted for the audible signal.

1116B.1.10 Hall call buttons. The centerline of the hall call buttons shall be 42 inches (1067 mm) above the floor. Buttons shall be a minimum of $\frac{3}{4}$ inch (19.1 mm) in size and shall be raised $\frac{1}{8}$ inch (3.2 mm) [plus or minus $\frac{1}{32}$ inch (0.8 mm)] above the surrounding surface. The button designating the up direction shall be on top. Visual indication shall be provided to show each call registered and extinguished when answered. Objects adjacent to, and below, hall call buttons shall not project more than 4 inches (102 mm) from the wall. Hall call buttons shall be internally illuminated with a white light over the entire surface of the button.

1116B.1.11 Handrails. A handrail shall be provided on one wall of the car; preferably the rear. The rails shall be smooth, and the inside surface at least $1\frac{1}{2}$ inches (38 mm) clear of the walls at a nominal height of 32 inches (813 mm) from the floor. Nominal equals ± 1 inch (25 mm). Thirty-two inches (813 mm) is required to reduce interference with car controls where the lowest button is centered at 35 inches (889 mm) above floor.

1116B.1.12 Minimum illumination. The minimum illumination at the car controls threshold and the landing when the car and landing doors are open shall not be less than 5 foot-candles (54 lux).

1116B.1.13 Hall lantern. A visual and audible signal shall be provided at each hoistway entrance indicating to the prospective passenger the car answering the call and its direction of travel as follows:

The visual signal for each direction shall be a minimum of $2\frac{1}{2}$ inches (64 mm) high by $2\frac{1}{2}$ inches (64 mm) wide and visible from the proximity of the hall call button.

The audible signal shall sound once for the "up" direction and twice for the "down" direction or shall have verbal annunciators that say "up" or "down."

The centerline of the fixture shall be located a minimum of 6 feet (1829 mm) in height from the lobby floor.

The use of in-car lanterns, located in or on the car doorjamb, visible from the proximity of the hall call buttons and conforming to the above requirements, shall or will be acceptable.

The use of arrow shapes is preferred for visible signals.

1116B.1.14 Doorjamb marking. Passenger elevator landing jambs on all elevator floors shall have the number of the floor on which the jamb is located designated by raised characters that are a minimum of 2 inches (51 mm) in height and conform to Section 1117B.5.5 and contracted Grade 2 Braille that conforms to Section 1117B.5.6 located 60 inches (1524 mm) on center above the floor on the jamb panels on both sides of the door so that they are visible from within the elevator. On the grade level, a raised five-pointed star shall be placed to the left of the raised character. The outside diameter of the star shall be 2 inches (51 mm).

Braille shall be placed below the corresponding raised characters.

The raised characters shall otherwise comply with Sections 1117B.5.3, 1117B.5.4 and 1117B.5.2. See Figure 11B-40C. Permanently applied plates are acceptable if they are permanently fixed to the jambs.

1116B.1.15 Location. Passenger elevators shall be on an accessible route, located near a major path of travel, and provisions shall be made to ensure that they remain accessible and usable at all times the building is occupied.

1116B.2 Platform (wheelchair) lifts. Platform (wheelchair) lifts may be provided between levels in lieu of passenger elevators when the vertical distance between landings, as well as the structural design and safeguards, are as allowed by ASME A18.1, Safety Standard for Platform Lifts and Stairway Chair Lifts; the State of California, Division of the State Architect—Access Compliance; the Department of Industrial Relations, Division of Occupational Safety and Health and any applicable safety regulations of other administrative authorities having jurisdiction.

If lifts are provided, they shall be designed and constructed to facilitate unassisted entry, operation and exit from the lift and shall comply with the restrictions and enhancements of this section in conjunction with Title 8 of the California Code of Regulations.

Additionally, lifts may be provided as part of an accessible route only for the following conditions:

1116B.2.1 To provide an accessible route to a performing area in an assembly occupancy, or to a speaking area or similar place (such as a dais or "head table") in an assembly or Group B occupancy.

1116B.2.2 To comply with the wheelchair viewing position line-of-sight and dispersion requirements of Section 1104B.3.5.

1116B.2.3 To provide access to incidental occupiable spaces and rooms which are not open to the general public and which house no more than five persons, including, but not limited to, equipment control rooms and projection booths.

1116B.2.4 To provide access where existing site constraints or other constraints make use of a ramp or an elevator infeasible.

1116B.2.4.1 Landing size. In new construction, the minimum size of landings specified in this section shall be 60 inches by 60 inches (1524 mm by 1524 mm). Other dimensions may be substituted where it can be demonstrated that a person using a wheelchair measuring 30 inches by 48 inches (762 mm by 1219 mm) can enter and operate the lift safely.

1116B.2.4.2 Relationship to the path of travel. Level and clear floor areas or landings as specified in this section shall be part of "path of travel" requirements.

Exceptions:

1. The provisions of this section shall not apply to existing buildings when physical constraints will not allow

compliance with these regulations or equivalent facilitation without creating an unreasonable hardship. See Section 109.1.

2. When the enforcing agency determines that compliance with any regulation under this section would create an unreasonable hardship, an exception to such regulation shall be granted when equivalent facilitation is provided.
3. The installation of lifts as part of an accessible route for additions or alterations is not limited to the four conditions required by Section 1116B.2.

1116B.3 When provided as a means of egress. Platform (wheelchair) lifts, when provided as a component in an accessible means of egress, shall conform to the requirements of Section 1116B.3.

1116B.3.1 Standby power. To ensure continued operation in case of primary power loss, platform (wheelchair) lifts shall be provided with standby power or with self-rechargeable battery power that provides sufficient power to operate all platform lift functions for a minimum of five upward and downward trips.

1116B.3.2 Platform (wheelchair) lifts, when provided per Section 1116B.2.2, are permitted to be a component of an accessible means of egress when the area served by the platform (wheelchair) lift does not serve more than four wheelchair viewing positions and where any one of the following conditions exist:

1. The building has a supervised automatic sprinkler system.
2. The maximum distance from the point where the wheelchair occupant is seated to a point where the occupant has a choice of two directions of travel to an exit shall not exceed 30 feet (9144 mm). The length of the path of travel shall include the vertical travel distance of the lift.

1116B.4 Doors and gates. Lifts shall have low energy power-operated doors or gates. Doors and gates shall remain open for 20 seconds minimum. End doors shall be 32 inches (813 mm) minimum clear width. Side doors shall be 42 inches (1067 mm) minimum clear width.

Exception: Lifts having doors or gates on opposite sides shall be permitted to have manual doors or gates.

SECTION 1117B OTHER BUILDING COMPONENTS

1117B.1 Accessible drinking fountains. Where drinking fountains are provided, they shall comply with this section:

1. **General.** Where only one drinking fountain area is provided on a floor, there shall be a drinking fountain that is accessible to individuals who use wheelchairs in accordance with this section and one accessible to those who have difficulty bending or stooping. This can be accommodated by the use of "hi-low" fountains, or by such other means as would achieve the required accessibility for each group on each floor.

Where more than one drinking fountain is provided on a floor, 50 percent of those provided shall comply with Items 1, 2, 4 and 5 of this section and shall be on an accessible route complying with Section 1114B.1.2. All drinking fountains shall comply with Item 3 of this section.

2. **Clearances.** Wall- and post-mounted cantilevered drinking fountains shall be a minimum of 18 inches (457 mm) and a maximum of 19 inches (483 mm) in depth and shall have a clear knee space between the bottom of the apron and the floor or ground not less than 27 inches (686 mm) in height, 30 inches (762 mm) in width, and 8 inches (203 mm) in depth, the depth measurements being taken from the front edge of the fountain back toward the wall or mounting post. The knee clearance space must be free of equipment or obstructions. Additionally, there shall be toe clearance of 9 inches (229 mm) in height above the floor and 17 inches (432 mm) in depth from the front edge of the fountain. The toe clearance space must be free of equipment or obstructions. A clear floor space at least 30 inches (762 mm) by 48 inches (1219 mm) complying with Section 1118B.4 shall be provided in front of the drinking fountain to allow forward approach. A side approach drinking fountain is not acceptable.
3. **Alcoves.** All drinking fountains shall be located completely within alcoves or otherwise positioned so as not to encroach into pedestrian ways. The alcove in which the drinking fountain is located shall not be less than 32 inches (813 mm) in width and 18 inches (457 mm) in depth. See Figure 11B-3 of this code. Additionally, alcoves shall comply with Section 1118B.4, Item 2. Protruding objects located in alcoves or otherwise positioned so as to limit encroachment into pedestrian ways are permitted to project 4 inches (102 mm) into walks, halls, corridors, passageways or aisles.

Exception: When the enforcing agency determines that it would create an unreasonable hardship to locate the drinking fountain in an alcove, the drinking fountain may project into the path of travel, and the path of travel shall be identifiable to the blind as follows. Wing walls shall be provided on each side of the drinking fountain. The wing walls shall project out from the supporting wall at least as far as the drinking fountain to within 6 inches (152 mm) of the surface of the path of travel. There shall also be a minimum of 32 inches (813 mm) clear between the wing walls. Additionally, maneuvering clearances shall comply with Section 1118B.4, Item 2. The drinking fountain and wing walls shall comply with Section 1133B.8.6.

4. The bubbler shall be activated by a manually operated system complying with Section 1117B.6, Item 4 that is front mounted or side mounted and located within 6 inches (152 mm) of the front edge of the fountain or an electronically controlled device (preferably). The bubbler outlet orifice shall be located within

6 inches (152 mm) of the front edge of the drinking fountain and within 36 inches (914 mm) of the floor. The water stream from the bubbler shall be substantially parallel to the front edge of the drinking fountain.

- The spout shall provide a flow of water at least 4 inches (102 mm) high so as to allow the insertion of a cup or glass under the flow of water. On an accessible drinking fountain with a round or oval bowl, the spout must be positioned so the flow of water is within 3 inches (75 mm) of the front edge of the fountain.

1117B.2 Telephones.

1117B.2.1 General. If public pay telephones, public closed-circuit telephones or other public telephones are provided, they shall comply with this section to the extent required by the following table. See Figure 11B-4.

Number of each type of telephone provided on each floor	Minimum number of telephones required to comply with Section 1117B.2 ¹
1 or more single units	At least 50 percent of telephone units per floor but not less than one.
1 telephone bank	At least 50 percent of telephone units per bank but not less than one.
2 or more banks	At least 50 percent of telephone units per bank but not less than one. At least 1 telephone per floor shall meet the requirements for a forward reach telephone.

¹Additional public telephones may be installed at any height.

1117B.2.2 Clear floor or ground space. A clear floor or ground space at least 30 inches by 48 inches (762 mm by 1219 mm) that allows either a forward or parallel approach by a person using a wheelchair shall be provided at telephones.

1117B.2.3 Size and approach. The minimum clear floor or ground space required to accommodate a single, stationary wheelchair and occupant is 30 inches by 48 inches (762 mm by 1219 mm). The minimum clear floor or ground space for wheelchairs may be positioned for forward or parallel approach to an object. Clear floor or ground space for wheelchairs may be part of the knee space required under some objects. See Figure 11B-5A.

1117B.2.4 Relationship of maneuvering clearances to wheelchair spaces. One full unobstructed side of the clear floor or ground space for a wheelchair shall adjoin another wheelchair clear floor space. If a clear floor space is located in an alcove or otherwise confined on all or part of three sides, additional maneuvering clearances shall be provided. See Figure 11B-5A.

1117B.2.5 Floor surfaces of wheelchair spaces. Floor surfaces of wheelchair spaces shall conform to Section 1124B. Bases, enclosures and fixed seats shall not impede approaches to telephones by people who use wheelchairs.

1117B.2.6 Mounting height. The highest operable part of the telephone shall be within the reach ranges specified in Sections 1118B.5 and 1118B.6. Telephones mounted diagonally in a corner that require wheelchair users to reach diagonally shall have the highest operable part no higher than 54 inches (1372 mm) above the floor. See Figure 11B-4.

nally in a corner that require wheelchair users to reach diagonally shall have the highest operable part no higher than 54 inches (1372 mm) above the floor. See Figure 11B-4.

1117B.2.7 Enclosures. If telephone enclosures are provided, they may overhang the clear floor space required in Sections 1117B.2.2, 1117B.2.3 and 1117B.2.4 within the following limits:

- Side reach possible.** Where a parallel approach is provided at a telephone within an enclosure, the enclosure and counter may extend beyond the face of the telephone a maximum of 10 inches (254 mm). The enclosure and counter may not overlap the required clear floor or ground space. See Figure 11B-4.
- Full-height enclosures.** Entrances to full-height enclosures shall be 30 inches (762 mm) minimum. See Figure 11B-4.
- Forward reach required.** Where a front approach is provided at a telephone within an enclosure, the counter may extend beyond the face of the telephone a maximum of 20 inches (508 mm) into the required clear floor or ground space and the enclosure may extend beyond the face of the telephone a maximum of 24 inches (610 mm). If an additional 6 inches (152 mm) in width of clear floor space is provided, creating a clear floor space of 36 inches by 48 inches (914 mm by 1219 mm), the enclosure may extend more than 24 inches (610 mm) beyond the face of the telephone. See Figure 11B-4.
- Protruding telephone enclosures.** Where telephone enclosures protrude into walks, halls, corridors or aisles, they shall also comply with Section 1133B.8.6.

1117B.2.8 Telephone equipment for hearing impaired persons. Telephones shall be equipped with a receiver that generates a magnetic field in the area of the receiver cap. All telephones required to be accessible shall be equipped with a volume control. In addition, 25 percent, but never less than one, of all other public telephones provided shall be equipped with a volume control and shall be dispersed among all types of public telephones, including closed circuit telephones, throughout the building or facility. If banks of public telephones are provided, at least one in each bank shall be equipped with a volume control. Such telephones shall be capable of a minimum of 12 dBA and a maximum of 18 dBA above normal. If an automatic reset is provided, 18 dBA may be exceeded. Public telephones with volume control shall be hearing aid compatible and shall be identified by a sign containing a depiction of a telephone handset with radiating sound waves.

1117B.2.9 Text telephones.

1117B.2.9.1 Where required.

- If a total of four or more public pay telephones (including both interior and exterior phones) are provided at a site, and if at least one of the total is in an interior location, then at least one interior public text telephone shall be provided.
- If an interior public pay telephone is provided in a stadium or arena, in a convention center, in a hotel

with a convention center or in a covered mall, at least one interior public text telephone shall be provided in the facility.

3. If a public pay telephone is located in or adjacent to a hospital emergency room, hospital recovery room or hospital waiting room, one public text telephone shall be provided at each location.

1117B.2.9.2 General. Text telephones shall comply with the following requirements:

1. Text telephones used with a pay telephone shall be permanently affixed within or adjacent to the telephone enclosure. If an acoustic coupler is used, the telephone cord shall be sufficiently long to allow connection of the text telephone and the telephone receiver.
2. Where a bank of telephones in the interior of a building consists of three or more public pay telephones, at least one public pay telephone in each such bank shall be equipped with a shelf and an electrical outlet within or adjacent to the telephone enclosure. The telephone handset shall be capable of being placed flush on the surface of the shelf. The shelf shall be capable of accommodating a text telephone and shall have 6 inches (152 mm) minimum vertical clearance in the area where the text telephone is to be placed.
3. Equivalent facilitation may be substituted for the requirements of this section. For example, a portable text telephone may be made available in a hotel at a registration desk if it is available on a 24-hour basis for use with nearby public pay phones. In this instance, at least one pay phone shall comply with Item 2 above. In addition, if an acoustic coupler is used, the telephone handset cord shall be sufficiently long to allow connection of the text telephone and the telephone receiver. Directional signage shall comply with Section 1117B.5.1 Items 2 and 3.

1117B.2.9.3 Signage. Text telephones shall be identified by the international TTY symbol (see Figure 11B-14A). If a facility has a public text telephone, directional signage indicating the location of the nearest such telephone shall be placed adjacent to all banks of telephones that do not contain a text telephone. Such directional signage shall include the international TTY symbol. If a facility has no banks of telephones, the directional signage shall be provided at the entrance or in a building directory.

1117B.2.10 Controls. Telephones shall have push-button controls where service for such equipment is available.

1117B.2.11 Cord length. The cord from the telephone to the handset shall be at least 29 inches (737 mm) long.

1117B.2.12 Telephone books. If telephone books are provided, they shall be located in a position that complies with the reach ranges in Sections 1118B.5 and 1118B.6.

1117B.3 Kitchens. See Section 1133A.

1117B.4 Swimming pools. See Section 1104B.4.3.

1117B.5 Signs and identification. California's standards for signage are more stringent than Section 4.30 of the ADA Standards for Accessible Design.

1117B.5.1 General. When new or additional signs and/or identification devices are provided, or when existing signs and/or identification devices are replaced or altered, the new or altered signs and/or identification devices shall comply with Section 1117B.5. The addition of or replacement of signs and/or identification devices shall not trigger any additional path of travel requirements.

1. **Identification signs.** When signs identify permanent rooms and spaces of a building or site, they shall comply with Sections 1117B.5.2, 1117B.5.3, 1117B.5.5, 1117B.5.6 and 1117B.5.7. For other means of egress signs and identification provisions adopted by SFM and DSA-AC, see Chapter 10, Sections 1011.3 for tactile exit signs, 1020.1.6.2 for tactile floor designation signs in stairways, 1008.1.8.6, Item 5 for delayed egress locks, 1007.6.5 for areas of refuge and 1007.7 for exits and elevators. See also Section 1116B for additional signage requirements applicable to elevators and Section 1115B.6 for sanitary facilities.
2. **Directional and informational signs.** When signs direct to or give information about permanent rooms and functional spaces of a building or site, they shall comply with Sections 1117B.5.2, 1117B.5.3 and 1117B.5.4.
3. **Accessibility signs.** When signs identify, direct to or give information about accessible elements and features of a building or site, they shall include the appropriate symbol of accessibility and shall comply with Sections 1117B.5.2 and 1117B.5.8.
4. **Plan review and inspection.** Signs and identification as specified in Section 1117B.5.1, when included in the construction of new buildings or facilities, or when included, altered or replaced due to additions, alterations or renovations to existing buildings or facilities, and when a permit is required, shall comply with the following plan review and inspection requirements:
 - 4.1. **Plan review.** Plans, specifications or other information indicating compliance with these regulations shall be submitted to the enforcing agency for review and approval.
 - 4.2. **Inspection.** Signs and identification shall be field inspected after installation and approved by the enforcing agency prior to the issuance of a final certificate of occupancy per Appendix Chapter 1, Section 110.2, or final approval where no certificate of occupancy is issued. The inspection shall include, but not be limited to, verification that Braille dots and cells are properly spaced and the size, proportion and type of raised characters are in compliance with these regulations.
 - 4.3. **Other signs and identification.** Tactile exit signage in Sections 1011.3 and 1011.3.2, tactile floor designation signs in stairways in

Section 1020.1.6.2, tactile special egress control device signs in Section 1008.1.8.6, Item 5, elevator car control identification required in Section 1116B.1.9, elevator doorjamb marking required in Section 1116B.1.14 and sanitary facilities signage required in Section 1115B.6 shall also comply with this section.

1117B.5.2 Finish and contrast. Characters, symbols and their background shall have a nonglare finish. Characters and symbols shall contrast with their background, either light on a dark background or dark on a light background.

1117B.5.3 Proportions. Characters on signs shall have a width-to-height ratio of between 3:5 and 1:1 and a stroke width-to-height ratio of between 1:5 and 1:10.

1117B.5.4 Character height. Characters and numbers on signs shall be sized according to the viewing distance from which they are to be read. The minimum height is measured using an uppercase X. Lowercase characters are permitted. For signs suspended or projected above the finish floor in compliance with Section 1133B.8.6, the minimum character height shall be 3 inches (76 mm).

1117B.5.5 Raised characters and pictorial symbol signs. When raised characters are required or when pictorial symbols (pictograms) are used on such signs, they shall conform to the following requirements:

1. **Character type.** Characters on signs shall be raised $\frac{1}{32}$ inch (0.794 mm) minimum and shall be sans serif uppercase characters accompanied by contracted (Grade 2) Braille complying with Section 1117B.5.6.
2. **Character size.** Raised characters shall be a minimum of $\frac{5}{8}$ inch (15.9 mm) and a maximum of 2 inches (51 mm) high.
3. **Pictorial symbol signs (pictograms).** Pictorial symbol signs (pictograms) shall be accompanied by the verbal description placed directly below the pictogram. The outside dimension of the pictogram field shall be a minimum of 6 inches (152 mm) in height.
4. **Character placement.** Characters and Braille shall be in a horizontal format. Braille shall be placed a minimum of $\frac{3}{8}$ inch (9.5 mm) and a maximum of $\frac{1}{2}$ inch (12.7 mm) directly below the tactile characters; flush left or centered. When tactile text is multilined, all Braille shall be placed together below all lines of tactile text.

1117B.5.6 Braille. Contracted (Grade 2) Braille shall be used wherever Braille is required in other portions of these standards. Dots shall be $\frac{1}{10}$ inch (2.54 mm) on center in each cell with $\frac{2}{10}$ -inch (5.08 mm) space between cells, measured from the second column of dots in the first cell to the first column of dots in the second cell. Dots shall be raised a minimum of $\frac{1}{40}$ inch (0.635 mm) above the background. Braille dots shall be domed or rounded.

1117B.5.7 Mounting location and height. Where permanent identification signs are provided for rooms and spaces, signs shall be installed on the wall adjacent to the latch side of the door. Where there is no wall space on the latch side,

including at double leaf doors, signs shall be placed on the nearest adjacent wall, preferably on the right.

Where permanent identification signage is provided for rooms and spaces they shall be located on the approach side of the door as one enters the room or space. Signs that identify exits shall be located on the approach side of the door as one exits the room or space.

Mounting height shall be 60 inches (1524 mm) above the finish floor to the center line of the sign. Mounting location shall be determined so that a person may approach within 3 inches (76 mm) of signage without encountering protruding objects or standing within the swing of a door.

See also Section 1115B.6 for additional signage requirements applicable to sanitary facilities.

1117B.5.8 Symbols of accessibility.

1117B.5.8.1 International Symbol of Accessibility. The International Symbol of Accessibility shall be the standard used to identify facilities that are accessible to and usable by physically disabled persons as set forth in these building standards and as specifically required in this section. See Figure 11B-6.

Exception: Signs need not be provided for facilities within an adaptable dwelling unit, or within an accessible patient or guest room.

1117B.5.8.1.1 Color of symbol. The symbol specified above shall consist of a white figure on a blue background. The blue shall be equal to Color No. 15090 in Federal Standard 595B.

Exception: The appropriate enforcement agency may approve other colors to complement decor or unique design. The symbol contrast shall be light on dark or dark on light.

1117B.5.8.1.2 Entrance signs. All building and facility entrances that are accessible to and usable by persons with disabilities shall be identified with a minimum of one International Symbol of Accessibility and with additional directional signs, utilizing the symbol, at junctions where the accessible route of travel diverges from the regular circulation path, to be visible to persons along approaching circulation paths. In existing buildings and facilities, entrances which are not accessible shall have directional signage complying with Section 1117B.5.1, Items 2 and 3, which indicates the location of and route to the nearest accessible entrance.

1117B.5.8.1.3 Information posted. Buildings that provide specific sanitary facilities and/or elevators for public use that conform to these building standards shall have this information posted in the building lobby, preferably as part of the building directory. The information shall be accompanied by the International Symbol of Accessibility. Inaccessible sanitary facilities shall have directional signage complying with Section 1117B.5.1, Items 2 and 3, to indicate the location of the nearest accessible sanitary facility.

1117B.5.8.2 International TTY symbol. Where the international TTY symbol is required, it shall comply with Figure 11B-14A.

1117B.5.8.3 Volume control telephones. Where telephones with volume controls are required to be identified, the identification symbol shall be a telephone handset with radiating sound waves, such as shown in Figure 11B-14B.

1117B.5.8.4 Assistive listening systems. Where assistive listening systems are required to be identified by the International Symbol of Access for Hearing Loss, it shall comply with Figure 11B-14C.

1117B.5.9 Traffic-control devices. Pole-supported pedestrian traffic-control buttons shall be identified with color coding consisting of a textured horizontal yellow band 2 inches (51 mm) in width encircling the pole, and a 1-inch-wide (25 mm) dark border band above and below this yellow band. Color coding should be placed immediately above the control button. Control buttons shall be located no higher than 48 inches (1219 mm) above the surface adjacent to the pole.

1117B.5.10 Signs for text telephones. Whenever signs shall refer to text telephones for people who are deaf or hard of hearing, the term "TTY" shall be used; the term "TDD" shall not be used.

1117B.5.11 Cleaner air symbol. Strictly for publicly funded facilities or any facilities leased or rented by state of California, not concessionaires. This symbol shall be the standard used to identify a room, facility and paths of travel that are accessible to and usable by people who are adversely impacted by airborne chemicals or particulate(s) and/or the use of electrical fixtures and/or devices. When used, the symbol shall comply with Figure 11B-40.

1117B.5.11.1 Color and size of symbol. The symbol shall be used when the following minimum conditions are met. The symbol, which shall include the text "Cleaner Air" as shown, shall be displayed either as a negative or positive image within a square that is a minimum of 6 inches (152 mm) on each side. The symbol may be shown in black and white or in color. When color is used, it shall be Federal Blue (Color No. 15090 Federal Standard 595B) on white, or white on Federal Blue. There shall be at least a 70-percent color contrast between the background of the sign from the surface that it is mounted on.

Strictly for publicly funded public facilities or any facilities leased or rented by State of California; not concessionaires.

1117B.5.11.2 Conditions of use. Use of the cleaner air symbol is voluntary. The cleaner air symbol shall be permitted for use to identify a path of travel, and a room or a facility when the following is met.

1. Floor or wall coverings, floor or wall covering adhesives, carpets, formaldehyde-emitting particleboard cabinetry, cupboards or doors have not been installed or replaced in the previous 12 months.

2. Incandescent lighting provided in lieu of fluorescent or halogen lighting, and electrical systems and equipment shall be operable by or on behalf of the occupant or user of the room, facility or path of travel.
3. Heating, ventilation, air conditioning and their controls shall be operable by or on behalf of the occupant or user.
4. To maintain "cleaner air" designation only nonirritating, nontoxic products will be used in cleaning, maintenance, disinfection, pest management or for any minimal touch-ups that are essential for occupancy of the area. Deodorizers or Fragrance Emission Devices and Systems (FEDS) shall not be used in the designated area. Pest control practices for cleaner air areas shall include the use of bait stations using boric acid, sticky traps and silicon caulk for sealing cracks and crevices. Areas shall be routinely monitored for pest problems. Additional nontoxic treatment methods, such as temperature extremes for termites, may be employed in the event of more urgent problems. These pest control practices shall not be used 48 hours prior to placement of the sign, and the facility shall be ventilated with outside air for a minimum of 24 hours following use or application.
5. Signage shall be posted requesting occupants or users not to smoke or wear perfumes, colognes or scented personal care products. Fragranced products shall not be used in the designated cleaner-air room, facility or path of travel.
6. A log shall be maintained on site, accessible to the public either in person or by telephone, e-mail, fax or other accessible means as requested. One or more individuals shall be designated to maintain the log. The log shall record any product or practice used in the cleaner air designated room, facility or path of travel, as well as scheduled activities, that may impact the cleaner air designation. The log shall also include the product label as well as the Material Safety Data Sheets (MSDS).

1117B.5.11.3 Removal of symbol. If the path of travel, room and/or facility identified by the cleaner air symbol should temporarily or permanently cease to meet the minimum conditions as set forth above, the cleaner air symbol shall be removed and shall not be replaced until the minimum conditions are again met.

1117B.6 Controls and operating mechanisms.

1. **General.** Controls and operating mechanisms in accessible spaces, along accessible routes or as parts of accessible elements (for example, light switches and dispenser controls) and those required to be accessible by Section 109.1 shall comply with the requirements of this section.
2. **Clear floor space.** Clear floor space complying with Section 1118B.4 that allows a forward or parallel approach by a person using a wheelchair shall be provided at controls, dispensers, receptacles and other operable equipment.

3. **Height.** The highest operable part of all controls, dispensers, receptacles and other operable equipment shall be placed within at least one of the reach ranges specified in Sections 1118B.5 and 1118B.6.

Exception: These requirements do not apply where the use of special equipment dictates otherwise or where electrical and communication systems receptacles are not normally intended for use by building occupants.

4. **Operation.** Controls and operating mechanisms shall be operable with one hand and shall not require tight grasping, pinching or twisting of the wrist. The force required to activate controls shall be no greater than 5 pounds (22.2 N) of force.

5. **Installation heights of electrical switches and receptacle outlets.**

5.1. **Electrical switches.** Controls and switches intended to be used by the occupant of the room or area to control lighting and receptacle outlets, appliances or cooling, heating and ventilating equipment, shall be located no more than 48 inches (1219 mm) measured from the top of the outlet box nor less than 15 inches (381 mm) measured from the bottom of the outlet box to the level of the finish floor or working platform.

5.2. **Electrical receptacle outlets.** Electrical receptacle outlets on branch circuits of 30 amperes or less and communication system receptacles shall be located no more than 48 inches (1219 mm) measured from the top of the receptacle outlet box or receptacle housing nor less than 15 inches (381 mm) measured from the bottom of the receptacle outlet box or receptacle housing to the level of the finish floor or working platform.

Exceptions:

1. Receptacle outlets installed as part of permanently installed baseboard heaters are exempt.
2. Required receptacle outlets shall be permitted in floors when adjacent to sliding panels or walls.
3. Baseboard electrical outlets used in relocatable partitions, window walls or other electrical convenience floor outlets are not subject to the minimum height requirements.
4. This section shall not apply to existing buildings when the enforcing agency determines that compliance with these standards would create an unreasonable hardship.

1117B.7 Automated teller machines and point of sale machines.

1117B.7.1 Definitions.

AUTOMATED TELLER MACHINE (ATM) means any electronic information processing device, including a point-of-sale machine, used by a financial institution

or other business entity and its customers for the primary purpose of executing financial transactions between itself and its customers. For the purposes of this section, "automated teller machine" includes point-of-sale machines used in grocery stores, ticket sales facilities and other business entities, but does not include card reading devices located on fuel pump islands at gasoline service stations and motor vehicle fuel facilities.

ATM SITE means that immediate area which is within or made or to be made part of an existing building or a building to be constructed, and to which one or more ATMs is or shall be affixed.

ATM INSTALLATION means a single ATM structurally affixed to a building or other structure.

1117B.7.2 General. Where ATMs are provided for the public, they shall comply with this section.

Exceptions:

1. In grocery stores and other retail outlets with point-of-sale machines located at individual check stands, machines that are located at accessible check stands must be made accessible. Where machines are located away from individual check stands, they must all be made accessible.
2. Where the enforcing agency determines that compliance with this regulation would create an unreasonable hardship, an exception may be granted when equivalent facilitation is provided through the use of other methods or materials.
3. In existing buildings, these regulations shall not apply when legal or physical constraints would not allow compliance with these regulations or equivalent facilitation without creating an unreasonable hardship. See Section 109.1.5.
4. Drive-up only ATMs are not required to comply with this section.
5. Card-reading devices located on fuel pump islands at gasoline service stations and motor vehicle fuel facilities are not required to comply with Sections 1114B through 1126B and all subsections there under.

1117B.7.3 Controls. Controls for user activation shall comply with the requirements of Section 1117B.6, Item 4, which states that controls and operating mechanisms shall be operable with one hand and shall not require tight grasping, pinching or twisting of the wrist. The force required to activate controls shall be no greater than 5 lbf (22.2 N).

1117B.7.4 Clearances and reach range. Free-standing or built-in units not having a clear space under them shall comply with the following as to clearance and reach range.

1117B.7.4.1 Where one ATM is provided. Where one ATM is provided at a location, it shall meet the specifications of Section 4.34 of the Americans with Disabilities Act Standards for Accessible Design as follows:

1. The ATM shall be located so that clear floor space complying with Section 1118B.4 is provided to al-

low a person using a wheelchair to make a forward approach, a parallel approach, or both, to the machine.

2. **Forward approach only.** If only a forward approach is possible, operable parts of all controls shall be placed within the forward reach range specified in Section 1118B.5.
3. **Parallel approach only.** If only a parallel approach is possible, operable parts of controls shall be placed as follows:
 - 3.1. **Reach depth not more than 10 inches (254 mm).** Where the reach depth to the operable parts of all controls as measured from the vertical plane perpendicular to the edge of the unobstructed clear floor space at the farthest protrusion of the ATM or surround is not more than 10 inches (254 mm), the maximum height from the floor shall be 54 inches (1372 mm).
 - 3.2. **Reach depth more than 10 inches (254 mm).** Where the reach depth to the operable parts of any control as measured from the vertical plane perpendicular to the edge of the unobstructed clear floor space at the farthest protrusion of the ATM or surround is more than 10 inches (254 mm), the maximum height from the floor shall be as shown in Table 11B-5.
4. **Forward and parallel approach.** If both a forward and parallel approach are possible, operable parts

of controls shall be placed within at least one of the reach ranges in Item 2 or 3.

5. **Bins.** Where bins are provided for envelopes, waste paper, or other purposes, at least one of each type provided shall comply with the applicable reach ranges in Item 2, 3 or 4.

Exception: Where a function can be performed in a substantially equivalent manner by using an alternate control, only one of the controls needed to perform that function is required to comply with this section. If the controls are identified by tactile markings, such markings shall be provided on both controls.

1117B.7.4.2 Where two ATMs are provided. Where two ATMs are provided at a location, one shall comply with Section 1117B.7.4.1, except that the highest operable part shall be 48 inches (1219 mm) maximum. The second ATM is not regulated as to height, including height of display.

1117B.7.4.3 Where three or more ATMs are provided. Where three or more ATMs are provided, two shall be used to satisfy Section 1117B.7.4.2 above. For the additional ATMs beyond the first two, at least 50 percent shall comply with Section 1117B.7.4.1. The remainder are not regulated as to height, including height of display. If features provided differ from ATM to ATM, all features shall be equally represented among the accessible ATMs.

1117B.7.5 Display. LED, cathode ray or other screen devices intended to be viewed by the user shall be positioned so they are readily visible to and usable by a person sitting in

**TABLE 11B-5
MAXIMUM REACH DEPTH FOR AUTOMATED TELLER MACHINES**

REACH DEPTH (X)	MAXIMUM HEIGHT (Y)
(inches)	(inches)
× 25.4 for mm	
10	54
11	53.5
12	53
13	52.5
14	51.5
15	51
16	50.5
17	50
18	49.5
19	49
20	48.5
21	47.5
22	47
23	46.5
24	46

See Figure 11B-5F (d).

a wheelchair with approximate eye level of 45 inches (1143 mm), and shall comply with the following requirements:

1. **Vertically mounted screen devices.** *If mounted vertically or tipped no more than 30 degrees away from the viewer, the center line of screens and other screen devices shall be located a maximum of 52 inches (1321 mm) above grade.*
2. **Angle-mounted screen devices.** *If mounted at an angle between 30 degrees and 60 degrees tipped away from the viewer, the center line of screens and other screen devices shall be located a maximum of 44 inches (1118 mm) above grade.*
3. **Horizontally mounted screen devices.** *If mounted at an angle between 60 degrees and 90 degrees tipped away from the viewer, the center line of screens and other screen devices shall be located a maximum of 34 inches (864 mm) above grade.*

Exception: *ATMs unregulated as to height in Sections 1117B.7.4 through 1117B.7.4.3 above are also exempt from this section.*

1117B.7.6 ATM equipment for persons with vision impairments. *Instructions and all information for use shall be made accessible to and independently usable by persons with vision impairments.*

1117B.8 Fitting and dressing rooms. *Where fitting or dressing rooms are provided for male or female customers, patients, employees or the general public, 5 percent, but never less than one, of dressings rooms for each type of use in each cluster of dressing rooms shall be accessible and located on an accessible route complying with Section 1114B.1.2. Examples of types of dressing rooms are those serving different genders or distinct and different functions as in different treatment or examination facilities. Where only unisex dressing rooms are provided, accessible unisex dressing rooms may be used to fulfill this requirement.*

Entry doors shall conform to the requirements of Section 1133B.2 and aisles leading to such doors shall conform to Sections 1133B.6.1 and 1133B.6.2.

The bottom of mirrors provided for use by persons with disabilities shall not be greater than 20 inches (508 mm) from the floor. Mirrors to be used by persons with disabilities shall be full length, measuring at least 18 inches (457 mm) wide by 54 inches (1372 mm) high, and shall be mounted in a position affording a view to a person on the bench as well as to a person in a standing position.

Clothing hooks shall be located not greater than 48 inches (1219 mm) from the floor.

Every accessible dressing room shall have a 24-inch by 48-inch (610 mm by 1219 mm) bench fixed to the wall along the longer dimension. The bench shall be mounted 17 to 19 inches (432 to 483 mm) above the finish floor. Clear floor space shall be provided alongside the bench to allow a person using a wheelchair to make a parallel transfer onto the bench. The structural strength of the bench and attachments shall comply with Section 1115B.7.2. Where installed in conjunction with showers, swimming pools or other wet locations, water shall

not accumulate upon the surface of the bench and the bench shall have a slip-resistant surface.

The minimum clear space within the room shall be 60 inches (1524 mm) in width and length. No door shall encroach into the required space.

1117B.9 Accessible sinks. *Sinks required to be accessible shall comply with this subsection.*

1. *A clear floor space at least 30 inches by 48 inches (762 mm by 1219 mm) complying with Section 1118B.4 shall be provided in front of a sink to allow forward approach. The clear floor space shall be on an accessible route and shall extend a maximum of 19 inches (485 mm) underneath the sink (see Figure 11B-1D).*
2. *Each accessible sink shall be a maximum of 6½ inches (165 mm) deep. Sinks shall be mounted with the counter or rim no higher than 34 inches (865 mm) above the finish floor. Knee clearance that is at least 27 inches (685 mm) high, 30 inches (762 mm) wide and 19 inches (485 mm) deep shall be provided underneath sinks. Hot water and drain pipes exposed under sinks shall be insulated or otherwise configured so as to protect against contact. There shall be no sharp or abrasive surfaces under sinks.*
3. *Faucet controls and operating mechanisms shall be operable with one hand and shall not require tight grasping, pinching or twisting of the wrist. The force required to activate controls shall be not greater than 5 lbf (22.2 N). Lever-operated, push-type and electronically controlled mechanisms are examples of acceptable designs. Self-closing valves are allowed if the faucet remains open for at least 10 seconds.*

SECTION 1118B SPACE ALLOWANCE AND REACH RANGES

1118B.1 Wheelchair passage width. *The minimum clear width for single wheelchair passage shall be 32 inches (813 mm) at a point and 36 inches (914 mm) continuously. See Figure 11B-10. In addition, wheelchair passage widths shall comply with Figure 11B-5E(a) and (b) for circulation around obstructions.*

1118B.2 Width for wheelchair passing. *The minimum width for two wheelchairs to pass is 60 inches (1524 mm). See Figure 11B-11.*

1118B.3 Wheelchair turning space. *The space required for a wheelchair to make a 180-degree turn is a clear space of 60 inches (1524 mm) diameter [see Figure 11B-12 (a)] or a T-shaped space. See Figure 11B-12 (b).*

1118B.4 Clear floor or ground space for wheelchairs.

1. **Size and approach.** *The minimum clear floor or ground space required to accommodate a single, stationary wheelchair and occupant is 30 inches by 48 inches (762 mm by 1219 mm). The minimum clear floor or ground space for wheelchairs may be positioned for forward or parallel approach to an object. Clear floor or ground space for wheelchairs may be part of the knee space required under some objects. See Figure 11B-5A.*

2. **Relationship of maneuvering clearances to wheelchair spaces.** One full unobstructed side of the clear floor or ground space for a wheelchair shall adjoin or overlap an accessible route or adjoin another wheelchair clear floor space. If a clear floor space is located in an alcove or otherwise confined on all or a part of three sides, additional maneuvering clearances shall be provided as shown in Figure 11B-5A(b).
3. **Surfaces for wheelchair spaces.** Clear floor or ground spaces for wheelchairs shall comply with Section 1124B Ground and Floor Surfaces.

1118B.5 Forward reach. If the clear floor space allows only forward approach to an object, the maximum high forward reach allowed shall be 48 inches (1219 mm) [see Figure 11B-5C (a)]. The minimum low forward reach is 15 inches (381 mm). If the high forward reach is over an obstruction, reach and clearances shall be as shown in Figure 11B-5C(b).

1118B.6 Side reach. If the clear floor space allows parallel approach by a person in a wheelchair, the maximum high side reach allowed shall be 54 inches (1372 mm) and the low side reach shall be no less than 9 inches (229 mm) above the floor [see Figure 11B-5D(a) and (b)]. If the side reach is over an obstruction, the reach and clearances shall be as shown in Figure 11B-5D(c).

SECTION 1119B SPECIAL STANDARDS OF ACCESSIBILITY FOR BUILDINGS WITH HISTORICAL SIGNIFICANCE

See Section 1135B.

SECTION 1120B FLOOR AND LEVELS

1120B.1 Floors within each story. In buildings and facilities, floors of a given story shall be a common level throughout, or shall be connected by pedestrian ramps, passenger elevators or platform (wheelchair) lifts.

Exceptions:

1. In existing buildings, other than dining banquet and bar facilities, when the enforcing agency determines that compliance with this section would create an unreasonable hardship, an exception shall be granted when equivalent facilitation is provided.
2. In existing dining, banquet and bar facilities, when the enforcing agency determines that compliance with this section would create an unreasonable hardship, an exception shall be granted, provided that a minimum of 75 percent of the dining, banquet and bar area shall be a common level throughout or shall be connected by pedestrian ramps, passenger elevators or special lifts and provided that the same services and décor are provided in an accessible space usable by the general public and are not restricted to use by people with disabilities.
3. In existing buildings, this section shall not apply when legal or physical constraints would not allow compliance with this section or equivalent facilitation with-

out creating an unreasonable hardship. See Section 109.1.5.

4. Where specifically exempted in other portions of this code.

1120B.2 Floor surface. The surface of floors shall be slip resistant and shall comply with Section 1124B.

SECTION 1121B TRANSPORTATION FACILITIES

1121B.1 General. Every station, bus stop, bus stop pad, terminal, building or other transportation facility shall incorporate the accessibility requirements of this code as modified by this chapter. The exceptions for elevators in Section 1103B do not apply to a terminal, depot or other station used for specified public transportation, or an airport passenger terminal, or facilities subject to Title II of the Americans with Disabilities Act.

1121B.2 Bus stops and terminals.

1121B.2.1 New construction. Where provided, bus stop pads shall have a firm, stable surface with a minimum clear length of 96 inches (2438 mm) (measured from the curb or vehicle roadway edge) and a minimum clear width of 60 inches (1524 mm) (measured parallel to the vehicle roadway) to the maximum extent allowed by legal or site constraints. Bus stop pads shall connect to streets, sidewalks or pedestrian paths as part of an accessible route complying with Section 1114B.1.2. Newly constructed bus stop pads must provide a square curb surface between the pad and road or other detectable warning in accordance with Section 1133B.8.5.

Bus stop pads shall be at the same slope as the roadway in the direction parallel to roadway, and maximum one unit vertical in 50 units horizontal (2-percent slope) perpendicular to roadway.

Where provided, bus stop shelters shall be installed so as to permit a wheelchair user to enter the shelter from the public way and access a clear floor area of 30 inches by 48 inches (762 mm by 1219 mm) complying with Section 1118B.4, completely within the shelter. Such shelters shall be connected by an accessible route to the boarding area. Where provided, all bus route identification signs shall comply with Section 1117B.5.1, Item 2.

Only approved DSA-AC detectable warning products and directional surfaces shall be installed as provided in the California Code of Regulations (CCR), Title 24, Part 1, Articles 2, 3 and 4. Refer to CCR Title 24, Part 12, Chapters 12-11A and B, for building and facility access specifications for product approval for detectable warning products and directional surfaces.

Detectable warning products and directional surfaces installed after January 1, 2001, shall be evaluated by an independent entity, selected by the Department of General Services, Division of the State Architect—Access Compliance, for all occupancies, including transportation and other outdoor environments, except that when products and surfaces are for use in residential housing, evaluation shall

be in consultation with the Department of Housing and Community Development. See Government Code Section 4460.

1121B.2.2 Bus stop siting and alterations.

1. Bus stop sites shall be chosen such that the areas where lifts or ramps are to be deployed comply with Section 1121B.2.1.
2. When new bus route identification signs are installed or old signs are replaced, they shall comply with the requirements of Section 1121B.2.1.

1121B.3 Fixed facilities and stations.

1121B.3.1 New construction. New stations in rapid rail, light rail, commuter rail, intercity bus, intercity rail, high speed rail and other fixed guideway systems (for example, automated guideway transit, monorails, etc.) shall comply with the following provisions, as applicable:

1. Elements such as ramps, elevators or other circulation devices, fare vending or other ticketing areas, and fare collection areas shall be placed to minimize the distance which wheelchair users and other persons who cannot negotiate steps may have to travel compared to the general public. The circulation paths, each including an accessible entrance and an accessible route, for persons with disabilities shall, to the maximum extent practicable, coincide with the circulation path for the general public. Where a circulation path is different, signage complying with Section 1117B.5.1, Items 2 and 3, shall be provided to indicate direction to and identify the accessible entrance and accessible route.
2. If different entrances to a station serve different transportation fixed routes or groups of fixed routes, entrances serving each group or route shall comply with Section 1133B.1.
3. Direct connections to commercial, retail or residential facilities shall have an accessible route complying with Section 1114B.1.2 from the point of connection to boarding platforms and all transportation system elements used by the public. Any elements provided to facilitate future direct connections shall be on an accessible route connecting boarding platforms and all transportation system elements used by the public.
4. Where signs are provided at entrances to stations identifying the station or the entrance, or both, at least one sign at each entrance shall comply with Section 1117B.5.1, Item 1. Such signs shall be placed in uniform locations at entrances within the transit system.

Exception: Where the station has no defined entrance, but signage is provided, the accessible signage shall be placed in a central location.

5. Stations covered by this section shall have identification signs complying with Section 1117B.5.1, Item 2. Signs shall be placed at frequent intervals and shall be clearly visible from within the vehicle on both sides when not obstructed by another train.

When station identification signs are placed close to vehicle windows (that is, on the side opposite from boarding) each shall have the top of the highest letter or symbol below the top of the vehicle window and the bottom of the lowest letter or symbol above the horizontal mid-line of the vehicle window.

6. Lists of stations, routes or destinations served by the station and located on boarding areas, platforms or mezzanines shall comply with Section 1117B.5.1, Item 2. A minimum of one sign identifying the specific station and complying with Section 1117B.5.1, Item 1, shall be provided on each platform or boarding area. All signs referenced in this paragraph shall be placed in uniform locations within the transit system.

7. Automatic fare vending, collection and adjustment (for example, add-fare) systems shall comply with Section 1117B.7. Such devices shall be located on an accessible route complying with Section 1114B.1.2.

If self-service fare collection devices are provided for the use of the general public, a minimum of 5 percent but not less than one accessible device for entering, and at least one for exiting, unless one device serves both functions, shall be provided at each location where such devices are provided.

Accessible fare collection devices shall have a minimum clear opening width of 32 inches (813 mm) and shall comply with the applicable requirements of Section 1117B.6.

Gates which must be pushed open by wheelchair or mobility aid users shall have a smooth continuous surface extending from 2 inches (51 mm) above the floor to 27 inches (686 mm) above the floor and shall comply with Sections 1133B.1 and 1133B.2.

8. Platform edges bordering a drop-off and not protected by platform screens or guards shall have a detectable warning. Such detectable warnings shall comply with the following provisions as applicable, and shall run the full length of the platform drop-off.

- (a) **Detectable warnings at transit boarding platforms.** Transit boarding platforms shall have a detectable warning texture extending the full length of the loading area. This detectable warning texture shall have the following features:

Width 24 to 36 inches (610 mm to 914 mm) placed at the edge of the drop-off or safe area.

Durable, slip-resistant material having a surface texture composed of raised, truncated domes in a staggered pattern with a diameter of nominal 0.9 inch (22.9 mm) at the base tapering to 0.45 inch (11.4 mm) at the top, a height of nominal 0.2 inch (5.08 mm), and a center-to-center spacing of nominal 2.35 inches (59.7 mm) in compliance with Figure 11B-23A. "Nominal" as used here shall be in accordance with California State Referenced Standards Code Sections 12-11A and B-102. The detectable warning shall contrast visually with

adjoining surfaces, either light on dark or dark on light. The material used to provide contrast shall be an integral part of the walking surface. Warning surfaces shall differ from adjoining walking surfaces in resiliency or sound-on-cane contact. This surface shall be reserved for warning.

Color yellow conforming to Federal Color No. 33538, as shown in Table IV of Standard No. 595B. Where the color value contrast between the yellow warning and the main walking surface is less than 70 percent, a 1 inch-wide (25 mm) black strip shall separate the yellow warning from the main walking surface. Contrast shall be determined by:

Contrast = $[(B1-B2/B1)] \times 100$ percent
where B1 = light reflectance value (LRV) of the lighter area and B2 = light reflectance value (LRV) of the darker area.

Only approved DSA-AC detectable warning products and directional surfaces shall be installed as provided in the California Code of Regulations (CCR), Title 24, Part 1, Articles 2, 3 and 4. Refer to CCR Title 24, Part 12, Chapters 12-11A and B, for building and facility access specifications for product approval for detectable warning products and directional surfaces.

Detectable warning products and directional surfaces installed after January 1, 2001, shall be evaluated by an independent entity, selected by the Department of General Services, Division of the State Architect—Access Compliance, for all occupancies, including transportation and other outdoor environments, except that when products and surfaces are for use in residential housing, evaluation shall be in consultation with the Department of Housing and Community Development. See Government Code Section 4460.

(b) **Detectable directional texture at boarding platforms.** At transit boarding platforms, the pedestrian access shall be identified with a detectable directional texture. This detectable directional texture shall comply with Figure 11B-23B and shall be 0.1 inch (2.54 mm) in height that tapers off to 0.04 inch (1.02 mm), with bars raised 0.2 inch (5.08 mm) from the surface. The raised bars shall be 1.3 inches (33.02 mm) wide and 3 inches (76 mm) from center-to-center of each bar. This surface shall differ from adjoining walking surfaces in resiliency or sound-on-cane contact. The color of the directional texture shall comply with Section 1121B.3.1, Item 8(a). This surface will be placed directly behind the yellow detectable warning texture specified in Section 1121B.3.1, Item 8(a), aligning with all doors of the transit vehicles where passengers will embark. The width of the directional texture shall be equal to the width of the transit vehicle's door opening. The depth of the texture shall not be less than 36 inches (914 mm).

Only approved DSA-AC detectable warning products and directional surfaces shall be installed as provided in the California Code of Regulations (CCR), Title 24, Part 1, Articles 2, 3 and 4. Refer to CCR Title 24, Part 12, Chapters 12-11A and B, for building and facility access specifications for product approval for detectable warning products and directional surfaces.

Detectable warning products and directional surfaces installed after January 1, 2001, shall be evaluated by an independent entity, selected by the Department of General Services, Division of the State Architect—Access Compliance, for all occupancies, including transportation and other outdoor environments, except that when products and surfaces are for use in residential housing, evaluation shall be in consultation with the Department of Housing and Community Development. See Government Code Section 4460.

9. In stations covered by this section, rail-to-platform height in new stations shall be coordinated with the floor height of new vehicles so that the vertical difference, measured when the vehicle is at rest, is within plus or minus $\frac{5}{8}$ inch (15.9 mm) under normal passenger load conditions.

For slow moving automated guideway "people mover" transit systems, the horizontal gap in new stations shall be no greater than 1 inch (25 mm).

Exceptions:

1. Existing vehicles operating in new stations may have a vertical difference with respect to the new platform within plus or minus 1 $\frac{1}{2}$ inches (38 mm).
 2. In light rail, commuter rail and intercity rail systems where it is not operationally or structurally feasible to meet the horizontal gap or vertical difference requirements, minihigh platforms, car-borne or platform-mounted lifts, ramps or bridge plates, or similar manually deployed devices, meeting the applicable requirements of 36 CFR Part 1192, or 49 CFR Part 38 shall suffice.
10. Stations shall not be designed or constructed so as to require persons with disabilities to board or alight from a vehicle at a location other than one used by the general public.
11. Illumination levels in the areas where signage is located shall be uniform and shall minimize glare on signs. Lighting along circulation routes shall be of a type and configuration to provide uniform illumination.
12. Text telephones. The following shall be provided in accordance with Sections 1117B.2.9.2 and 1117B.2.9.3:

(a) If an interior public pay telephone is provided in a transit facility (as defined by the federal Department of Transportation) at least one inte-

rior public text telephone shall be provided in the station.

(b) Where four or more public pay telephones serve a particular entrance to a rail station and at least one is in an interior location, at least one interior public text telephone complying with Sections 1117B.2.9.2 and 1117B.2.9.3 shall be provided to serve that entrance.

13. Where it is necessary to cross tracks to reach boarding platforms, the route surface shall be level and flush with the rail top at the outer edge and between rails, except for a maximum 2¹/₂-inch (64 mm) gap on the inner edge of each rail to permit passage of wheel flanges. Such crossings shall comply with Section 1133B.8.5. Where gap reduction is not practicable, an above-grade or below-grade accessible route shall be provided.
14. Where public address systems are provided to convey information to the public in terminals, stations, or other fixed facilities, a means of conveying the same or equivalent information to persons with hearing loss or who are deaf shall be provided.
15. Where clocks are provided for use by the general public, the clock face shall be uncluttered so that its elements are clearly visible. Hands, numerals, and/or digits shall contrast with the background either light-on-dark or dark-on-light. Where clocks are mounted overhead, numerals and/or digits shall comply with Section 1117B.5.4. Clocks shall be placed in uniform locations throughout the facility and system.
16. Where provided in below-grade stations, escalators shall have a minimum clear width of 32 inches (813 mm). At the top and bottom of each escalator run, at least two contiguous treads shall be level beyond the comb plate before the risers begin to form. All escalator treads shall be marked by a strip of clearly contrasting color, 2 inches (51 mm) in width, placed parallel to and on the nose of each step. The strip shall be of a material that is at least as slip resistant as the remainder of the tread. The edge of the tread shall be apparent from both ascending and descending directions.
17. Where provided, elevators shall be glazed or have transparent panels to allow an unobstructed view both into and out of the car. Elevators shall comply with Section 1116B.

Exception: Elevator cars with a clear floor area in which a 60-inch-diameter (1524 mm) circle can be inscribed may be substituted for the minimum car dimensions of Section 1116B and Figure 11B-40A.

18. Where provided, ticketing areas shall comply with Section 1122B.5, and the customer side of the baggage check-in area shall be accessible.
19. Where provided, baggage check-in and retrieval systems shall be on an accessible route complying

with Section 1114B.1.2 and shall have space immediately adjacent complying with Section 1118B.

If unattended security barriers are provided, at least one gate shall comply with Sections 1133B.1 and 1133B.2. Passageways containing security barriers shall comply with Section 1133B.2.3.4.

Gates which must be pushed open by wheelchair or mobility aid users shall have a smooth continuous surface extending from 2 inches (51 mm) above the floor to 27 inches (686 mm) above the floor.

1121B.3.2 Existing facilities—alterations. Alterations of transportation facilities shall comply with Section 1134B.

1121B.4 Airports.

1121B.4.1 New construction.

1. Elements such as ramps, elevators or other vertical circulation devices, ticketing areas, security checkpoints or passenger waiting areas shall be placed to provide equitable travel distances for wheelchair users and other persons who cannot negotiate steps compared to the route for the general public.
2. The circulation paths, each including an accessible entrance and an accessible route, for persons with disabilities shall, to the maximum extent practicable, coincide with the circulation path for the general public. Where a circulation path is different, signage complying with Section 1117B.5.1, Items 2 and 3, shall be provided to indicate direction to and identify the accessible entrance and accessible route.
3. Where provided, ticketing areas shall comply with Section 1122B.5, and the customer side of the baggage check-in area shall be accessible.
4. Where public pay telephones are provided, and at least one is at an interior location, a public text telephone shall be provided in compliance with Sections 1117B.2.9.2 and 1117B.2.9.3. Additionally, if four or more public pay telephones are located in any of the following locations, at least one public text telephone shall also be provided in that location: (a) a main terminal outside the security areas; (b) a concourse within the security areas; or (c) a baggage claim area in a terminal.
5. Where provided, baggage check-in and retrieval systems shall be on an accessible route complying with Section 1114B.1.2 and shall have space immediately adjacent complying with Section 1118B.
If unattended security barriers are provided, at least one gate shall comply with Sections 1133B.1 and 1133B.2. Passageways containing security barriers shall comply with Section 1133B.2.3.4.
Gates which must be pushed open by wheelchair or mobility aid users shall have a smooth continuous surface extending from 2 inches (51 mm) above the floor to 27 inches (686 mm) above the floor.
6. Terminal information systems which broadcast information to the general public through a public address system shall provide a means to provide the same or equivalent information to persons with a hearing loss

or who are deaf. Such methods may include, but are not limited to, visual paging systems using video monitors and computer technology. For persons with certain types of hearing loss such methods may include, but are not limited to, an assistive listening system complying with Section 1104B.2.

7. Where clocks are provided for use by the general public the clock face shall be uncluttered so that its elements are clearly visible. Hands, numerals and/or digits shall contrast with their background either light-on-dark or dark-on-light. Where clocks are mounted overhead, numerals and/or digits shall comply with Section 1117B.5.4. Clocks shall be placed in uniform locations throughout the facility.

SECTION 1122B FIXED OR BUILT-IN SEATING, TABLES AND COUNTERS

1122B.1 Minimum number. Where fixed or built-in seating, tables or counters are provided in accessible public use or common use areas, 5 percent, but never less than one, must be accessible as provided in this section. An accessible route of travel complying with Section 1114B.1.2 shall lead to and through such fixed or built-in seating areas or tables.

1122B.2 Seating. If seating spaces for persons in wheelchairs are provided at fixed tables or counters, clear floor space complying with Section 1118B.4 shall be provided. Such clear floor space shall not overlap knee space by more than 19 inches (483 mm) (see Figure 11B-13).

1122B.3 Knee clearance. If seating for persons in wheelchairs is provided at fixed tables or counters, knee spaces at least 27 inches (686 mm) high, 30 inches (762 mm) wide and 19 inches (483 mm) deep shall be provided (see Figure 11B-13).

Exception: Knee clearance is not required at checkout counters or service counters.

1122B.4 Height of work surfaces. The tops of tables and counters shall be 28 inches to 34 inches (711 mm to 864 mm) from the floor or ground.

Where a single counter contains more than one transaction station, such as (but not limited to) a bank counter with multiple teller windows or a retail sales counter with multiple cash register stations, at least 5 percent, but never less than one, of each type of station shall be located at a section of counter that is at least 36 inches (914 mm) long and no more than 28 to 34 inches (711 to 864 mm) high.

1122B.5 Sales and service counters, teller windows, and information counters. In department stores and miscellaneous retail stores where counters have cash registers and are provided for sales or distribution of goods or services to the public, at least one of each type shall have a portion of the counter which is at least 36 inches (915 mm) in length with a maximum height of 34 inches (864 mm) above the finish floor and located on an accessible route complying with Section 1114B.1.2.

At ticketing counters, teller stations in a bank, registration counters in hotels and motels, box office ticket counters and other counters that may not have a cash register but at which goods or services are sold or distributed, a portion of the main counter which is a minimum of 36 inches (915 mm) in length shall be provided with a maximum height of 34 inches (864 mm).

Exception: In existing buildings where it is determined that providing an accessible counter would create an unreasonable hardship, equivalent facilitation may consist of one of the following:

1. An auxiliary counter, in close proximity to the main counter, meeting these requirements may be provided.
2. Provision of a folding shelf attached to the main counter on which an individual with disabilities can write.

SECTION 1123B ACCESS TO EMPLOYEE AREAS

1123B.1 General. Employee areas shall conform to all requirements of the Division of the State Architect—Access Compliance in the California Building Code, Plumbing Code and Electrical Code.

1123B.2 Work stations. Specific work stations need only comply with aisle width (Sections 1133B.6.1 and 1133B.6.2) and floors and levels (Section 1120B), and entryways shall be 32 inches (813 mm) in clear width.

Exception: Accessibility is not required to (1) observation galleries used primarily for security purposes; or (2) in nonoccupiable spaces accessed only by ladders, catwalks, crawl spaces, very narrow passageways or freight (nonpassenger) elevators, and frequented only by service personnel for repair purposes; such spaces include, but are not limited to, elevator pits, elevator penthouses, mechanical rooms, piping or equipment catwalks.

SECTION 1124B GROUND AND FLOOR SURFACES

1124B.1 General. Ground and floor surfaces along accessible routes and in accessible rooms and spaces, including floors, walks, ramps, stairs and curb ramps, shall be stable, firm, slip resistant and shall comply with this section.

1124B.2 Changes in level. Changes in level up to $\frac{1}{4}$ inch (6.4 mm) may be vertical and without edge treatment [see Figure 11B-5E(c)]. Changes in level between $\frac{1}{4}$ inch (6.4 mm) and $\frac{1}{2}$ inch (12.7 mm) shall be beveled with a slope no greater than one unit vertical in 2 units horizontal (50-percent slope) [see Figure 11B-5E(d)]. Changes in level greater than $\frac{1}{2}$ inch (12.7 mm) shall be accomplished by means of a curb ramp, ramp, elevator or platform lift that complies with Section 1127B.5, 1133B.5, 1116B.1 or 1116B.2, respectively.

1124B.3 Carpet. If carpet or carpet tile is used on a ground or floor surface, then it shall be securely attached; have a firm cushion, pad or backing or no cushion or pad; and have a level loop, textured loop, level-cut pile or level-cut/uncut pile tex-

ture. The maximum pile height shall be $\frac{1}{2}$ inch (12.7 mm). See Figure 11B-7E(b). Exposed edges of carpet shall be fastened to floor surfaces and have trim along the entire length of the exposed edge. Carpet edge trim shall comply with Section 1124B.2.

1124B.4 Gratings. If gratings are located in walking surfaces, then they shall have spaces no greater than $\frac{1}{2}$ inch (12.7 mm) wide in one direction (see Figure 11B-7E). If gratings have elongated openings, then they shall be placed so that the long dimension is perpendicular to the dominant direction of travel (see Figure 11B-7E).

SECTION 1125B STORAGE

1125B.1 General. If fixed storage facilities such as cabinets, shelves, closets or drawers are provided where access is required by Section 109.1, at least one of each type shall comply with this section. Additional storage may be provided outside of the reach ranges shown in Figure 11B-5D.

1125B.2 Clear floor space. A clear floor space at least 30 inches by 48 inches (762 mm by 1219 mm) complying with Section 1118B.4 that allows either a forward or parallel approach by a person using a wheelchair shall be provided at accessible storage facilities.

1125B.3 Height. Accessible storage spaces shall be within at least one of the reach ranges specified in Sections 1118B.5 and 1118B.6. Clothes rods shall be a maximum of 54 inches (1372 mm) from the floor for a side approach (See Figure 11B-5D). Where the distance from the wheelchair to the clothes rod or shelf exceeds 10 inches (254 mm), as in closets without accessible doors, the height and depth to the rod or shelf shall comply with Figure 11B-5D.

1125B.4 Hardware. Hardware for accessible storage facilities shall comply with Section 1117B.6. Touch latches and U-shaped pulls are acceptable.

SECTION 1126B VENDING MACHINES AND OTHER EQUIPMENT

Spaces for vending machines and other equipment shall comply with Section 1118B and shall be located on an accessible route complying with Section 1114B.1.2. Controls for vending machines and other equipment shall comply with Section 1117B.6, Controls and Operating Mechanisms.

Division II—SITE ACCESSIBILITY

SECTION 1127B EXTERIOR ROUTES OF TRAVEL

1127B.1 General. Site development and grading shall be designed to provide access to all entrances and exterior ground floor exits, and access to normal paths of travel, and where necessary to provide access, shall incorporate pedestrian ramps, curb ramps, etc. Access shall be provided within the boundary of the site from public transportation stops, accessible parking spaces, passenger loading zones if provided, and public streets or sidewalks. When more than one building or facility is located on a site, accessible routes of travel complying with Section 1114B.1.2 shall be provided between buildings and accessible site facilities, accessible elements, and accessible spaces that are on the same site. The accessible route of travel shall be the most practical direct route between accessible building entrances, accessible site facilities and the accessible entrance to the site. If access is provided for pedestrians from a pedestrian tunnel or elevated walkway, entrances to the building from each tunnel or walkway must be accessible.

Exceptions:

1. Where the enforcing agency determines that compliance with these regulations would create an unreasonable hardship because of topography, natural barriers, etc., an exception may be granted when equivalent facilitation is provided through the use of other methods and materials.
2. In existing buildings, this section shall not apply in those conditions where, due to legal or physical constraints, the site of the project would not allow compliance with these regulations or equivalent facilitation without creating an unreasonable hardship. See Section 109.1.5.

1127B.2 Design and construction. When accessibility is required by this section, it shall be designed and constructed in accordance with this code. See Section 1114B.1 for a list of applicable sections.

1127B.3 Signs. At every primary public entrance and at every major junction where the accessible route of travel diverges from the regular circulation path along or leading to an accessible route of travel, entrance or facility, there shall be a sign displaying the International Symbol of Accessibility. Signs shall indicate the direction to accessible building entrances and facilities and shall comply with the requirements found in Sections 1117B.5.1, Item 2, and 1117B.5.8.1.

1127B.4 Outside stairways. See Section 1133B.4.

1127B.5 Curb ramps.

1. **General.** Curb ramps shall be constructed at each corner of street intersections and where a pedestrian way crosses a curb. Built-up curb ramps shall be located so that they do not project into vehicular traffic lanes. The preferred and recommended location for curb ramps is in the center of the crosswalk of each street corner. Where it is necessary to locate a curb ramp in the center of the

curb return and the street surfaces are marked to identify pedestrian crosswalks, the lower end of the curb ramp shall terminate within such crosswalk areas. See Figure 11B-20C, Case E and Figure 11B-22.

2. **Width of curb ramps.** Curb ramps shall be a minimum of 4 feet (1219 mm) in width and shall lie, generally, in a single sloped plane, with a minimum of surface warping and cross slope.
3. **Slope of curb ramps.** The slope of curb ramps shall not exceed one unit vertical in 12 units horizontal (8.33-percent slope). The slope shall be measured as shown in Figure 11B-20E. Transitions from ramps to walks, gutters or streets shall be flush and free of abrupt change. Maximum slopes of adjoining gutters, road surface immediately adjacent to the curb ramp, or accessible route shall not exceed one unit vertical in 20 units horizontal (5-percent slope) within 4 feet (1219 mm) of the top and bottom of the curb ramp. The slope of the fanned or flared sides of curb ramps shall not exceed one unit vertical in 10 units horizontal (10-percent slope).
4. **Level landing.** A level landing 4 feet (1219 mm) deep shall be provided at the upper end of each curb ramp over its full width to permit safe egress from the ramp surface, or the slope of the fanned or flared sides of the curb ramp shall not exceed one unit vertical in 12 units horizontal (8.33-percent slope).
5. **Finish.** The surface of each curb ramp and its flared sides shall comply with Section 1124B, Ground and Floor Surfaces, and shall be of contrasting finish from that of the adjacent sidewalk.
6. **Border.** All curb ramps shall have a grooved border 12 inches (305 mm) wide at the level surface of the sidewalk along the top and each side approximately $\frac{3}{4}$ inch (19 mm) on center. All curb ramps constructed between the face of the curb and the street shall have a grooved border at the level surface of the sidewalk. See Figures 11B-19A and 11B-19B.
7. **Detectable warnings.** Curb ramps shall have a detectable warning that extends the full width and depth of the curb ramp, excluding the flared sides, inside the grooved border. Detectable warnings shall consist of raised truncated domes with a diameter of nominal 0.9 inch (22.9 mm) at the base tapering to 0.45 inch (11.4 mm) at the top, a height of nominal 0.2 inch (5.08 mm) and a center-to-center spacing of nominal 2.35 inches (59.7 mm) in compliance with Figure 11B-23A. "Nominal" here shall be in accordance with Sections 12-11A and B-102, State Referenced Standards Code. The detectable warning shall contrast visually with adjoining surfaces, either light-on-dark or dark-on-light. The material used to provide contrast shall be an integral part of the walking surface. The domes may be constructed in a variety of methods, including cast in place or stamped, or may be part of a prefabricated surface treatment.

Only approved DSA-AC detectable warning products and directional surfaces shall be installed as provided in the California Code of Regulations (CCR), Title 24, Part 1, Articles 2, 3 and 4. Refer to CCR Title 24, Part 12, Chapters 12-11A and B, for building and facility access

specifications for product approval for detectable warning products and directional surfaces.

Detectable warning products and directional surfaces installed after January 1, 2001, shall be evaluated by an independent entity, selected by the Department of General Services, Division of the State Architect—Access Compliance, for all occupancies, including transportation and other outdoor environments, except that when products and surfaces are for use in residential housing, evaluation shall be in consultation with the Department of Housing and Community Development. See Government Code Section 4460.

8. **Obstructions.** Curb ramps shall be located or protected to prevent their obstruction by parked vehicles.
9. **Diagonal curb ramps.** If diagonal (or corner-type) curb ramps have returned curbs or other well-defined edges, such edges shall be parallel to the direction of pedestrian flow. The bottom of diagonal curb ramps shall have 48 inches (1219 mm) minimum clear space as shown in Figures 11B-22(c) and (d). If diagonal curb ramps are provided at marked crossings, the 48-inch (1219 mm) clear space shall be within the markings [see Figures 11B-22(c) and (d)]. If diagonal curb ramps have flared sides, they shall also have at least a 24 inch (610 mm) long segment of straight curb located on each side of the curb ramp and within the marked crossing [see Figure 11B-22 (c)].

Notes:

1. For additional curb details, see Figures 11B-19A and 11B-19B.
2. If the distance from the curb to the back of sidewalk is too short to accommodate a ramp and a 4-foot (1219 mm) platform as in Figure 11B-20A, Case A, the sidewalk may be depressed longitudinally as in Figure 11B-20A, Case B, or Figure 11B-20B, Case C, or may be widened as in Figure 11B-20B, Case D.
3. If the sidewalk is less than 5 feet (1524 mm) wide, the full width of the sidewalk shall be depressed as shown in Figure 11B-20B, Case C.
4. As an alternate to Figure 11B-20A, Case A, one ramp may be placed in the center of the curb return as in Figure 11B-20C, Case E.
5. When a ramp is located in the center of a curb return, the crosswalk configuration must be similar to that shown on the plan to accommodate wheelchairs. See Figure 11B-22.
6. If the planting area width is equal to or greater than the ramp length, the ramp side slope distance equals 3 feet (914 mm). See Figure 11B-20D, Case G.
7. For Figure 11B-20C, Case F, and Figure 11B-20D, Case G, the longitudinal portion of the sidewalk may need to be depressed as shown in Figure 11B-20A, Case B.

8. If located on a curve, the sides of the ramp need not be parallel, but the minimum width of the ramp shall be 4 feet (1219 mm).
9. The ramp shall have a 12-inch-wide (305 mm) border with $\frac{1}{4}$ -inch (6 mm) grooves approximately $\frac{3}{4}$ inch (19 mm) on center. See grooving detail, Figure 11B-20D, Case H.

SECTION 1128B PEDESTRIAN GRADE SEPARATIONS (OVERPASSES AND UNDERPASSES)

Pedestrian ramps on pedestrian grade separations shall comply with the requirements of Section 1133B.5 for ramps.

Cross slopes of walking surfaces shall be the minimum possible and shall not exceed one unit vertical in 50 units horizontal (2-percent slope). The slope of any appreciably warped walking surface shall not exceed one unit vertical in 12 units horizontal (8.33-percent slope) in any direction. Where pedestrian grade separations cross streets or other vehicular traffic ways, and where a street level crossing can reasonably and safely be used by persons with physical disabilities, there shall be provided conforming curb ramps and a usable pathway.

Exceptions:

1. When the grade differential of the walking surface of a pedestrian grade separation exceeds 14 feet (4267 mm) due to required height clearance and grade conditions, and the enforcing agency finds that because of right-of-way restrictions, topography or natural barriers, wheelchair accessibility or equivalent facilitation would create an unreasonable hardship, such accessibility need not be provided. However, the requirements in these regulations relating to other types of mobility shall be complied with.
2. For existing facilities, this section shall not apply where, due to legal or physical constraints, the site of the project will not allow compliance with these regulations or equivalent facilitation without creating an unreasonable hardship. See Section 109.1.5.

SECTION 1129B ACCESSIBLE PARKING REQUIRED

1129B.1 General. Each lot or parking structure where parking is provided for the public as clients, guests or employees, shall provide accessible parking as required by this section. Accessible parking spaces serving a particular building shall be located on the shortest accessible route of travel (complying with Section 1114B.1.2) from adjacent parking to an accessible entrance. In parking facilities that do not serve a particular building, accessible parking shall be located on the shortest accessible route of travel to an accessible pedestrian entrance of the parking facility. In buildings with multiple accessible entrances with adjacent parking, accessible parking spaces shall be dispersed and located closest to the accessible entrances. Table 11B-6 establishes the number of accessible parking spaces required.

1129B.2 Medical care outpatient facilities. At facilities providing medical care and other services for persons with mobility impairments, parking spaces complying with this section shall be provided in accordance with Table 11B-6 except as follows:

1. **Outpatient units and facilities.** Ten percent of the total number of parking spaces provided shall serve each such outpatient unit or facility.
2. **Units and facilities that specialize in treatment or services for persons with mobility impairments.** Twenty percent of the total number of parking spaces provided shall serve each such unit or facility.

**TABLE 11B-6
SPACES REQUIRED**

Establishes the number of accessible parking spaces required.

TOTAL NUMBER OF PARKING SPACES IN LOT OR GARAGE	MINIMUM REQUIRED NUMBER OF SPACES
1-25	1
26-50	2
51-75	3
76-100	4
101-150	5
151-200	6
201-300	7
301-400	8
401-500	9
501-1,000	*
1,001 and over	**

* Two percent of total.

** Twenty plus one for each 100, or fraction over 1,001.

1129B.3 Parking space size. Accessible parking spaces shall be located as near as practical to a primary entrance and shall be sized as follows:

1. **Dimensions.** Where single spaces are provided, they shall be 14 feet (4267 mm) wide and lined to provide a 9-foot (2743 mm) parking area and a 5-foot (1524 mm) loading and unloading access aisle on the passenger side of the vehicle. When more than one space is provided in lieu of providing a 14-foot-wide (4267 mm) space for each parking space, two spaces can be provided within a 23-foot-wide (7010 mm) area lined to provide a 9-foot (2743 mm) parking area on each side of a 5-foot (1524 mm) loading and unloading access aisle in the center. The loading and unloading access aisle shall be marked by a border painted blue. Within the blue border, hatched lines a maximum of 36 inches (914 mm) on center shall be painted a color contrasting with the parking surface, preferably blue or white. See Figure 11B-18A. Parking access aisles shall be part of an accessible route of travel (complying with Section 1114B.1.2) to the building or facility entrance. Parked vehicle overhangs shall not reduce the clear width of an accessible route. The minimum length of each parking space, shall be 18 feet (5486 mm). The words "NO PARKING" shall be painted on the ground within each 5-foot (1524 mm) loading and unloading access aisle. This notice shall be painted in white

letters no less than 12 inches (305 mm) high and located so that it is visible to traffic enforcement officials. See Figures 11B-18A, 11B-18B and 11B-18C.

2. **Van space(s).** One in every eight accessible spaces, but not less than one, shall be served by a loading and unloading access aisle 96 inches (2438 mm) wide minimum placed on the side opposite the driver's side when the vehicle is going forward into the parking space and shall be designated van accessible as required by Section 1129B.4. All such spaces may be grouped on one level of a parking structure. The loading and unloading access aisle shall be marked by a border painted blue. Within the blue border, hatched lines a maximum of 36 inches (914 mm) on center shall be painted a color contrasting with the parking surface, preferably blue or white. The words "NO PARKING" shall be painted on the ground within each 8-foot (2438 mm) loading and unloading access aisle. This notice shall be painted in white letters no less than 12 inches (305 mm) high and located so that it is visible to traffic enforcement officials. See Figures 11B-18A, 11B-18B and 11B-18C.
3. **Arrangement of parking space.** In each parking area, a bumper or curb shall be provided and located to prevent encroachment of cars over the required width of walkways. Also, the space shall be so located that persons with disabilities are not compelled to wheel or walk behind parked cars other than their own. Pedestrian ways which are accessible to persons with disabilities shall be provided from each such parking space to related facilities, including curb cuts or ramps as needed. Ramps shall not encroach into any accessible parking space or the adjacent access aisle.

Exceptions: See Figures 11B-18A through 11B-18C.

1. Where the enforcing agency determines that compliance with any regulation of this section would create an unreasonable hardship, a variance or waiver may be granted when equivalent facilitation is provided.
2. Parking spaces may be provided which would require a person with a disability to wheel or walk behind other than accessible parking spaces when the enforcing agency determines that compliance with these regulations or providing equivalent facilitation would create an unreasonable hardship. See Section 109.1.5.
4. **Slope of parking space and access aisle.** Surface slopes of accessible parking spaces and access aisles shall be the minimum possible and shall not exceed one unit vertical in 50 units horizontal (2-percent slope) in any direction.

1129B.4 Identification of parking spaces for off-street parking facilities. Each parking space reserved for persons with disabilities shall be identified by a reflectorized sign permanently posted immediately adjacent to and visible from each stall or space, consisting of the International Symbol of Accessibility in white on a dark blue background. The sign shall not be smaller than 70 square inches (4516 mm²) in area and, when in a path of travel, shall be posted at a minimum height of 80

inches (2032 mm) from the bottom of the sign to the parking space finished grade. Signs may also be centered on the wall at the interior end of the parking space. An additional sign or additional language below the symbol of accessibility shall state "Minimum Fine \$250."

Van accessible spaces complying with Section 1129B.3, Item 2 shall have an additional sign or additional language stating "Van Accessible" below the symbol of accessibility. Signs identifying accessible parking spaces shall be located so they cannot be obscured by a vehicle parked in the space.

An additional sign shall also be posted in a conspicuous place at each entrance to off-street parking facilities, or immediately adjacent to and visible from each accessible stall or space. The sign shall not be less than 17 inches by 22 inches (432 mm by 559 mm) in size with 1 inch (25 mm) high minimum lettering which clearly and conspicuously states the following:

"Unauthorized vehicles parked in designated accessible spaces not displaying distinguishing placards or special license plates issued for persons with disabilities will be towed away at the owner's expense. Towed vehicles may be reclaimed at _____ or by telephoning _____."

Blank spaces are to be filled in with appropriate information as a permanent part of the sign.

In addition to the above requirements, the surface of each accessible parking space or stall shall have a surface identification duplicating either of the following schemes:

1. By outlining or painting the stall or space in blue and outlining on the ground in the stall or space in white or suitable contrasting color a profile view depicting a wheelchair with occupant; or
2. By outlining a profile view of a wheelchair with occupant in white on blue background. The profile view shall be located so that it is visible to a traffic enforcement officer when a vehicle is properly parked in the space and shall be 36 inches high by 36 inches wide (914 mm by 914 mm). See Figures 11B-18A through 11B-18C.

SECTION 1130B PARKING STRUCTURES

All entrances to and vertical clearances within parking structures shall have a minimum vertical clearance of 8 feet 2 inches (2489 mm) where required for accessibility to accessible parking spaces.

Exceptions:

1. Where the enforcing agency determines that compliance with Section 1130B would create an unreasonable hardship, an exception may be granted when equivalent facilitation is provided.
2. This section shall not apply to existing buildings where the enforcing agency determines that, due to legal or physical constraints, compliance with these regulations or equivalent facilitation would create an unreasonable hardship. See Section 109.1.5.

SECTION 1131B PASSENGER DROP-OFF AND LOADING ZONES

1131B.1 Location. When provided, passenger drop-off and loading zones shall be located on an accessible route of travel (complying with Section 1114B.1.2) and shall comply with 1131B.2.

1131B.2 Passenger loading zones.

1. **General.** Where provided, one passenger drop-off and loading zone shall provide an access aisle at least 60 inches (1524 mm) wide and 20 feet (6096 mm) long adjacent and parallel to the vehicle pull-up space. Vehicle standing spaces and access aisles shall be level with surface slopes not exceeding one unit vertical in 50 units horizontal (2-percent slope) in all directions. If there are curbs between the access aisle and the vehicle pull-up space, a curb ramp shall be provided. Each passenger drop-off and loading zone designed for persons with disabilities shall be identified by a reflectorized sign, complying with Section 1117B.5.1, Items 2 and 3, permanently posted immediately adjacent to and visible from the passenger drop-off or loading zone stating "Passenger Loading Zone Only" and including the International Symbol of Accessibility, in white on a dark blue background.
2. **Vertical clearance.** Provide minimum vertical clearance of 114 inches (2896 mm) at accessible passenger loading zones and along at least one vehicle access route to such areas from site entrances and exits.

1131B.3 Valet parking. Valet parking facilities shall provide a passenger loading zone complying with Section 1131B.2 above and shall be located on an accessible route of travel (complying with Section 1114B.1.2) to the entrance of the facility. The parking space requirements of Sections 1129B through 1130B apply to facilities with valet parking.

1131B.4 Bus stop pads and shelters. See Section 1121B.2.1.

SECTION 1132B OUTDOOR OCCUPANCIES

1132B.1 General. Outdoor occupancies shall be accessible as required in this chapter. See also the general requirements in Section 1114B.1.1.

1132B.2 Parks and recreational areas. The following parks and recreational areas shall comply with these regulations.

Exceptions:

1. In existing buildings, when the enforcing agency determines that compliance would create an unreasonable hardship, a variance shall be granted when equivalent facilitation is provided.
2. Where the enforcing agency finds that, in specific areas, the natural environment would be materially damaged by compliance with these regulations, such areas shall be subject to these regulations only to the extent that such material damage would not occur.
3. Automobile access shall not be provided or paths of travel shall not be made accessible when the enforc-

ing agency determines that compliance with these regulations would create an unreasonable hardship.

1. **Campsites.** Campsites, a minimum of two and no fewer than three for each 100 campsites provided, shall be accessible by a level path or ramp and shall have travel routes with slopes not exceeding one unit vertical in 12 units horizontal (8.33-percent slope) to sanitary facilities. Permanent sanitary facilities serving campgrounds shall be accessible to wheelchair occupants.
2. **Beaches, picnic areas.** Beaches, picnic areas, day-use areas, vista points and similar areas shall be accessible.
3. **Sanitary facilities.** Sanitary facilities, to the extent that such facilities are provided, each public use area that is accessible to wheelchair occupants by automobile, walks or other paths of travel.
4. **Boat docks.** Boat docks, fishing piers, etc., shall be accessible.
5. **Parking lots.** Parking lots shall be provided with accessible parking spaces and with curb cuts leading to all adjacent walks, paths or trails.
6. **Trails and paths.** Trails, paths and nature walk areas, or portions of these, shall be constructed with gradients which will permit at least partial use by wheelchair occupants. Hard surface paths or walks shall be provided to serve buildings and other functional areas.
7. **Nature trails.** Nature trails and similar educational and informational areas shall be accessible to the blind by the provision of rope guidelines, raised Arabic numerals and symbols for identification, information signs and related guide and assistance devices.

For museums, orientation buildings, visitor centers, office buildings, retail stores, restaurants, etc., and sanitary facilities serving these uses, see Sections 1104B through 1111B and sections listed in Section 1114B.1.1.

1132B.3 Highway rest areas. The specific standards of accessibility for highway rest areas and similar facilities shall be as follows in Section 1132B.3.1, subject to other provisions in these regulations.

1132B.3.1 Permanent facilities. At least one kind of permanent functional area or facility, as applicable, shall be accessible to persons with disabilities, including:

1. A sanitary facility for each sex.
2. At least one picnic table and one additional table for each 20 tables, or fraction thereof provided.
3. Information and display areas.
4. Drinking fountains.
5. At least one parking space.
6. Curb ramps conforming to Section 1127B.5 shall be provided at pedestrian ways where appropriate.

Division III—ACCESSIBILITY FOR ENTRANCES, EXITS AND PATHS OF TRAVEL

This division includes additional requirements which supersede less restrictive requirements in Chapter 10 where access is required.

SECTION 1133B GENERAL ACCESSIBILITY FOR ENTRANCES, EXITS AND PATHS OF TRAVEL

1133B.1 Building accessibility. See this chapter.

1133B.1.1 Entrances.

1133B.1.1.1 Entrances and exterior ground floor exit doors.

1133B.1.1.1.1 All entrances and exterior ground-floor exit doors to buildings and facilities shall be made accessible to persons with disabilities. Such entrances shall be connected by an accessible route (complying with Section 1114B.1.2) to public transportation stops, to accessible parking and passenger loading zones and to public streets or sidewalks, if available. Entrances shall be connected by an accessible route to all accessible spaces or elements within the building or facility. Doorways shall have a minimum clear opening of 32 inches (813 mm) with the door open 90 degrees, measured between the face of the door and the opposite stop (see Figure 11B-5B). Openings more than 24 inches (610 mm) in depth shall comply with Section 1118B.1.

Exceptions:

1. Exterior ground-floor exits serving smoke-proof enclosures, stairwells and exit doors servicing stairs only need not be made accessible.
2. Exits in excess of those required by Chapter 10, and which are more than 24 inches (610 mm) above grade are not required to be accessible. Such doors shall have signs warning that they are not accessible. Warning signs shall comply with Section 1117B.5.1, Item 2.
3. In existing buildings where the enforcing agency determines that compliance with the building standards of this section would create an unreasonable hardship, an exception shall be granted when equivalent facilitation is provided. Equivalent facilitation would require at least one entrance to be accessible to and usable by persons with disabilities.
4. These building standards shall not apply to existing buildings when legal or physical constraints will not allow compliance with these building standards or equivalent facilitation without creating an unreasonable

hardship. See Section 109.1.5, Special Conditions for Persons with Disabilities Requiring Appeals Action Ratification.

1133B.1.1.1.2 Temporary restrictions. During periods of partial or restricted use of a building or facility, the entrances used for primary access shall be accessible to and usable by persons with disabilities.

1133B.1.1.1.3 Recessed doormats. Recessed doormats shall be adequately anchored to prevent interference with wheelchair traffic.

1133B.1.1.1.4 Gates. All gates, including ticket gates, shall meet all applicable specifications for doors.

1133B.1.1.1.5 Service entrances. In existing buildings and facilities, a service entrance shall not be the sole accessible entrance unless it is the only entrance to a building or facility (for example, in a factory or garage).

1133B.2 Doors.

1133B.2.1 Type of lock or latch. See Chapter 10, Section 1008.1.8.

1133B.2.2 Width and height. Every required exit doorway shall be of a size as to permit the installation of a door not less than 3 feet (914 mm) in width and not less than 6 feet 8 inches (2032 mm) in height.

When installed in exit doorways, exit doors shall be capable of opening at least 90 degrees and shall be so mounted that the clear width of the exitway is not less than 32 inches (813 mm) measured between the face of the door and the opposite stop (see Figure 11B-5B). In computing the exit width the net dimension of the exitway shall be used.

Exception: Doors not requiring full user passage, such as shallow closets, may have the clear opening reduced to 20 inches (510 mm) minimum.

1133B.2.3 Hinged doors. For hinged doors, the opening width shall be measured with the door positioned at an angle of 90 degrees from its closed position.

1133B.2.3.1 Pairs of doors. Where a pair of doors is utilized, at least one of the doors shall provide a clear, unobstructed opening width of 32 inches (813 mm) with the leaf positioned at an angle of 90 degrees from its closed position.

1133B.2.3.2 Automatic and power-assisted doors. If an automatic door is used, then it shall comply with BHMA A156.10. Slowly opening, low-powered, automatic doors shall comply with BHMA A156.19. Such doors shall not open to back check faster than 3 seconds and shall require no more than 15 lbf (66.72 N) to stop door movement. If a power-assisted door is used, its door-opening force shall comply with Section 1133B.2.5 and its closing shall conform to the requirements in BHMA A156.19. When an automatic door operator is utilized to operate a pair of doors, at least one of the doors shall provide a clear, unobstructed opening width of 32 inches (813 mm) with the door positioned at an angle of 90 degrees from its closed position.

Exceptions:

1. The provisions of Section 1133B.2.3 shall not apply to existing buildings, except when otherwise required under conditions applicable to access for persons with disabilities. In existing buildings, the following shall apply:

Where the occupant load is less than 10, except Group I, Division 1 occupancies, or where the occupant load is greater than 10 and it is determined that compliance with Section 1133B.2.3 would create an unreasonable hardship, a projection of $5/8$ inch (16 mm) maximum will be permitted for the latch side stop.

2. In existing buildings, the provisions of this section shall not apply when legal or physical constraints will not allow compliance with these building standards or equivalent facilitation without creating an unreasonable hardship. See Section 109.1.5.

1133B.2.3.3 Revolving doors. Revolving doors shall not be used as a required entrance for persons with disabilities.

1133B.2.3.4 Turnstiles, rails and pedestrian controls. Where turnstiles and crowd control barriers are utilized in a facility for the purpose of providing fully controlled access, such as where an admission price is charged, a door or gate that is accessible to persons with disabilities shall be provided adjacent to each turnstile exit or entrance. This alternate passageway shall be maintained in an unlocked condition during business hours and the door or gate shall not activate a publicly audible alarm system. The door or gate may be latched where all gates are restricted and controlled by an attendant and a sign is posted stating, "All gates are restricted and controlled by an attendant." The accessible door or gate shall provide the same use pattern. Where posts, rails or other pedestrian controls are utilized to create crowd control aisles or lanes, a minimum of one lane shall be accessible and shall provide a minimum aisle width no less than indicated in Figures 11B-5E(a) and (b) with 32 inches (813 mm) of clear opening.

Exception: In existing buildings, Section 1133B.2.3 shall not apply when physical constraints or equivalent facilitation will not allow compliance with these building standards without creating an unreasonable hardship. See Section 109.1.5.

1133B.2.4 Floor level at doors. Regardless of the occupant load, there shall be a floor or landing on each side of a door.

1133B.2.4.1 Thresholds. The floor or landing shall not be more than $1/2$ inch (12.7 mm) lower than the threshold of the doorway. Change in level between $1/4$ inch (6 mm) and $1/2$ inch (12.7 mm) shall be beveled with a slope no greater than one unit vertical in 2 units horizontal (50-percent slope). Change in level greater than $1/2$ inch (12.7 mm) shall be accomplished by means of a ramp. See Section 1133B.5.1.

1133B.2.4.2 Maneuvering clearances at doors. Minimum maneuvering clearances at doors shall be as shown in Figures 11B-26A and 11B-26B. The floor or ground area within the required clearances shall be level and clear.

The level area shall have a length in the direction of door swing of at least 60 inches (1524 mm) and the length opposite the direction of door swing of 48 inches (1219 mm) as measured at right angles to the plane of the door in its closed position.

Exception: The length opposite the direction of door swing shall be a minimum of 44 inches (1118 mm) where the door has no closer and approach to the door by a person in a wheelchair can be made from the latch side, or if the door has neither latch nor closer and approach can be made from the hinge side. See Figures 11B-26A and 11B-26B.

1133B.2.4.3 The width of the level area on the side to which the door swings shall extend 24 inches (610 mm) past the strike edge of the door for exterior doors and 18 inches (457 mm) past the strike edge for interior doors.

Twenty-four inches (610 mm) is preferred for strike-side clearance.

1133B.2.4.4 The space between two consecutive door openings in a vestibule, serving other than a required exit stairway shall provide a minimum of 48 inches (1219 mm) of clear space from any door opening into such vestibule when the door is positioned at an angle of 90 degrees from its closed position. Doors in a series shall swing either in the same direction or away from the space between the doors. See Figures 11B-30 and 11B-31.

1133B.2.4.5 Where a door required to be accessible by Section 1133B.1.1.1 is located in a recess or alcove where the distance from the face of the wall to the face of the door is greater than 8 inches (203 mm), strike side clearances as prescribed in Section 1133B.2.4.3 shall be provided. See Figure 11B-33(a).

1133B.2.5 Door Opening Force. The maximum force required to push or pull open a door shall comply with this section. Push or pull force for a hinged door shall be measured perpendicular to the door face at the door opening hardware or 30 inches (762 mm) from the hinged side, whichever is farther from the hinge. Push or pull force for a sliding or folding door shall be measured parallel to the door at the door pull or latch. Compensating devices or automatic door operators complying with Section 1133B.2.3.2 may be used to meet the maximum force limits.

1. Required fire doors shall have the minimum opening force allowable by the appropriate administrative authority, not to exceed 15 lbf (66.7 N).
2. Other than required fire doors, interior doors shall have a maximum opening force of 5 lbf (22.2 N).
3. Other than required fire doors, exterior doors shall have a maximum opening force of 5 lb (22.2 N).

Exceptions:

1. Exterior doors to machinery spaces including, but not limited to, elevator pits or elevator pent-houses; mechanical, electrical or communications equipment rooms; piping or equipment catwalks; electric substations and transformer vaults; and highway and tunnel utility facilities.
2. When, at a single location, one of every 8 exterior door leafs, or fraction of 8, is a powered door, other exterior doors at the same location, serving the same interior space, may have a maximum opening force of 8.5 lbf (37.8 N). The powered leaf(s) shall be located closest to the accessible route.
 - a. Powered doors shall comply with Section 1133B.2.3.2. Powered doors shall be fully automatic doors complying with Builders Hardware Manufacturers' Association (BHMA) A156.10 or low energy operated doors complying with BHMA A156.19.
 - b. Powered doors serving a building or facility with an occupancy of 150 or more shall be provided with a back-up battery or back-up generator. The back-up power source shall be able to cycle the door a minimum of 100 cycles.
 - c. Powered doors shall be controlled on both the interior and exterior sides of the doors by sensing devices, push plates, vertical actuation bars or other similar operating devices complying with Section 1117B.6.

At each location where push plates are provided there shall be two push plates; the centerline of one push plate shall be 7 inches (178 mm) minimum and 8 inches (203 mm) maximum above the floor or ground surface and the centerline of the second push plate shall be 30 inches (762 mm) minimum and 44 inches (1219 mm) maximum above the floor or ground surface. Each push plate shall be a minimum of 4 inches (102 mm) diameter or a minimum of 4 inches by 4 inches (102 mm by 102 mm) square and shall display the International Symbol of Accessibility complying with Section 1117B.5.8.1.

At each location where vertical actuation bars are provided the operable portion shall be located so the bottom is 5 inches (127 mm) maximum above the floor or ground surface and the top is 35 inches (889 mm) minimum above the floor or ground surface. The operable portion of each vertical actuation bar shall be a minimum of 2 inches (51 mm) wide and shall display the International Symbol of Accessibility complying with Section 1117B.5.8.1.

Where push plates, vertical actuation bars or other similar operating devices are provided, they shall be placed in a conspicu-

ous location. A level and clear floor or ground space for forward or parallel approach complying with Sections 1118B.4 and 1124B.1 shall be provided, centered on the operating device. Doors shall not swing into the required clear floor or ground space.

- d. Signage identifying the accessible entrance required by Section 1127B.3 shall be placed on, or immediately adjacent to, each powered door. Signage shall be provided in compliance with BHMA A156.10 or BHMA 156.19, as applicable.
- e. In addition to the requirements of Item d, where a powered door is provided in buildings or facilities containing assembly occupancies of 300 or more, a sign displaying the International Symbol of Accessibility measuring 6 inches by 6 inches (152 mm by 152 mm), complying with Section 1117B.5.8.1, shall be provided above the door on both the interior and exterior sides of each powered door.

1133B.2.5.1 Door closer. If the door has a closer, then the sweep period of the closer shall be adjusted so that from an open position of 70 degrees, the door will take at least 3 seconds to move to a point 3 inches (75 mm) from the latch, measured to the leading edge of the door.

1133B.2.5.2 Hand-activated door opening hardware, handles, pulls, latches, locks, and other operating devices on accessible doors shall have a shape that is easy to grasp with one hand and does not require tight grasping, tight pinching or twisting of the wrist to operate. Hardware shall be centered between 30 inches (762 mm) and 44 inches (1118 mm) above the floor. Latching and locking doors that are hand-activated and which are in a path of travel shall be operable with a single effort by lever-type hardware, panic bars, push-pull activating bars or other hardware designed to provide passage. Locked exit doors shall operate as above in egress direction.

1133B.2.5.3 Recessed doors. Where the plane of the doorway is offset 8 or more inches (205 mm) from any obstruction within 18 inches (455 mm) measured laterally on the latch side, the door shall be provided with maneuvering clearance for front approach. See Figure 11B-33(a).

1133B.2.6 Smooth surface. The bottom 10 inches (254 mm) of all doors except automatic and sliding shall have a smooth, uninterrupted surface to allow the door to be opened by a wheelchair footrest without creating a trap or hazardous condition. Where narrow frame doors are used, a 10-inch (254 mm) high smooth panel shall be installed on the push side of the door, which will allow the door to be opened by a wheelchair footrest without creating a trap or hazardous condition.

1133B.3 Corridors, hallways and exterior exit balconies.

1133B.3.1 Corridor and hallway widths. Every corridor and hallway serving an occupant load of 10 or more shall not be less than 44 inches (1118 mm) in width. Corridors and hallways serving an occupant load of less than 10 shall not be less than 36 inches (914 mm) in width.

1133B.3.2 Corridors and hallways over 200 feet (60 960 mm). Corridors and hallways that are located on an accessible route and exceed 200 feet (60 960 mm) in length shall have a minimum clear width of 60 inches (1524 mm). If an accessible route has less than 60 inches (1524 mm) clear width, then passing spaces at least 60 inches by 60 inches (1524 mm by 1524 mm) shall be located at intervals of 200 feet (60 960 mm) maximum. A "T" intersection of two corridors or walks is an acceptable passing place.

Exceptions:

1. In existing buildings, when the enforcing agency determines that compliance with any building standard under this section would create an unreasonable hardship, an exception to such building standard shall be granted when equivalent facilitation is provided.
2. In existing buildings, the provisions of this section shall not apply when legal or physical constraints will not allow compliance with these building standards or equivalent facilitation without creating an unreasonable hardship. See Section 109.1.5.

1133B.4 Stairways.

1133B.4.1 Handrails.

1133B.4.1.1 Required handrails. Stairways shall have handrails on each side. Handrails shall be continuous along both sides of a stairway. Intermediate handrails shall be provided as required in Section 1012.8.

1133B.4.2 Handrail configuration.

1133B.4.2.1 The top of handrail gripping surface shall be mounted between 34 to 38 inches (864 to 965 mm) above the nosing of the treads.

1133B.4.2.2 Handrails shall extend a minimum of 12 inches (305 mm) beyond the top nosing and 12 inches (305 mm), plus the tread width, beyond the bottom nosing. At the top, the extension shall be parallel with the floor or ground surface. At the bottom, the handrail shall continue to slope for a distance of the width of one tread from the bottom riser; the remainder of the extension shall be horizontal. See Figures 11B-35 and 11B-37.

Exceptions:

1. In new construction, the inside handrail on switchback or dogleg stairs shall always be continuous.
2. In existing buildings and facilities, full extension of handrails at stairs shall not be required in alterations where such extensions would be hazardous or impossible due to plan configuration.

1133B.4.2.3 Ends shall be returned smoothly to floor, wall or post.

1133B.4.2.4 The orientation of at least one handrail shall be in the direction of the run of the stair and perpendicular to the direction of the stair nosing, and shall not reduce the minimum required width of the stairs.

1133B.4.2.5 Handrails projecting from a wall shall have a space of 1½ inches (38 mm) between the wall and the handrail.

Handrails may be located in a recess if the recess is a maximum of 3 inches (76 mm) deep and extends at least 18 inches (457 mm) above the top of the rail. Handrails shall not rotate in their fittings.

1133B.4.2.6 Handgrips. The handgrip portion of handrails shall be not less than 1¼ inches (32 mm) or more than 1½ inches (38 mm) in cross-sectional nominal dimension or the shape shall provide an equivalent gripping surface. The handgrip portion of handrails shall have a smooth surface with no sharp corners. Gripping surfaces (top or sides) shall be uninterrupted by newel posts, other construction elements or obstructions. Any wall or other surface adjacent to the handrail shall be free of sharp or abrasive elements. Edges shall have a minimum radius of 1/8 inch (3.2 mm).

Exceptions:

1. In existing buildings when the enforcing agency determines that compliance with any requirement under Section 1133B.4.2 would create an unreasonable hardship, an exception to the requirement for persons with disabilities may be granted when equivalent facilitation is provided.
2. These regulations shall not apply in existing buildings where legal or physical constraints will not allow compliance with these regulations or equivalent facilitation without creating an unreasonable hardship. See Section 109.1.5.

1133B.4.3 Tactile floor designation signs in stairways. Tactile floor designation signs that comply with Section 1117B.5, Item 1, shall be located at each floor level landing in all enclosed stairways in buildings two or more stories in height to identify the floor level. At exit discharge level, the sign shall include a raised five-pointed star located to the left of the identifying floor level. The outside diameter of the star shall be the same as the height of the raised characters.

1133B.4.4 Striping for the visually impaired. Interior stairs shall have the upper approach and lower tread marked by a stripe providing clear visual contrast. Exterior stairs shall have the upper approach and all treads marked by a stripe providing clear visual contrast.

The stripe shall be a minimum of 2 inches (50.8 mm) wide to a maximum of 4 inches (101.6 mm) wide placed parallel to, and not more than 1 inch (25.4 mm) from, the nose of the step or upper approach. The stripe shall extend the full width of the step or upper approach and shall be of material that is at least as slip resistant as the other treads of the stair. A painted stripe shall be acceptable.

1133B.4.5 Stair treads, risers and nosing. Stair treads shall be no less than 11 inches (279 mm) deep, measured from

riser to riser. Stair riser heights shall be 7 inches (178 mm) maximum and 4 inches (102 mm) minimum. On any given flight of stairs, all steps shall have uniform riser height and uniform tread widths.

1133B.4.5.1 Treads. All tread surfaces shall be slip resistant. Weather-exposed stairs and their approaches shall be designed so that water will not accumulate on the walking surfaces. Treads shall have smooth, rounded or beveled exposed edges.

1133B.4.5.2 Risers. Risers shall be solid and shall be vertical [see Figure 11B-35(a)] or sloped from the underside of the leading edge of the tread above at an angle not more than 30 degrees (0.52 rad) from the vertical [see Figure 11B-35(b)]. Open risers are not permitted.

1133B.4.5.3 Nosing. The radius of curvature at the leading edge (nosing) of the tread shall be no greater than 1/2 inch (12.7 mm). Beveling of nosings shall not exceed 1/2 inch (12.7 mm). Nosings shall not project more than 1 1/4 inches (31.8 mm) past the face of the riser below. Nosings that project beyond risers shall have the underside of the leading edge beveled at an angle not more than 30 degrees (0.52 rad) from the vertical (see Figure 11B-35(c)). The transition from the nosing to the riser shall be free of abrupt edges. All projections shall be of uniform size, including nosings at landings.

Exceptions:

1. In existing buildings there is no requirement to retroactively alter existing nosing projections of 1 1/2 inches (38.1 mm) which were constructed in compliance with the building code in effect at the time of original construction.
2. In existing buildings, when the enforcing agency determines that compliance with any requirement under this section would create an unreasonable hardship, an exception to persons with disabilities requirements may be granted when equivalent facilitation is provided.
3. These regulations shall not apply to existing buildings when legal or physical constraints will not allow compliance with these regulations or equivalent facilitation without creating an unreasonable hardship. See Section 109.1.5.

1133B.5 Ramps.

1133B.5.1 General. Ramps shall conform to the provisions of this section. Any accessible route of travel shall be considered a ramp if its slope is greater than one unit vertical in 20 units horizontal (5-percent slope).

1133B.5.2 Width. Ramps shall have a minimum clear width of 48 inches (1219 mm), unless required to be wider by some other provision of this code. Ramps serving entrances to buildings where the ramp is the only exit discharge path and serves an occupant load of 300 or more shall have a minimum clear width of 60 inches (1524 mm). Ramps serving Group R occupancies may be 36 inches (914 mm) clear width when the occupant load is 50 or less.

1133B.5.3 Slope. The least possible slope shall be used for any ramp. The maximum slope of a ramp shall be one unit vertical in 12 units horizontal (8.33-percent slope). The maximum rise for any run shall be 30 inches (762 mm). Examples of ramp dimensions are as follows:

SLOPE	MAXIMUM RISE	MAXIMUM LENGTH
1:12	30 inches (762 mm)	30 feet (9144 mm)
1:13	30 inches (762 mm)	32.5 feet (9906 mm)
1:14	30 inches (762 mm)	35 feet (10668 mm)
1:15	30 inches (762 mm)	37.5 feet (11430 mm)
1:16	30 inches (762 mm)	40 feet (12192 mm)
1:17	30 inches (762 mm)	42.5 feet (12954 mm)
1:18	30 inches (762 mm)	45 feet (13716 mm)
1:19	30 inches (762 mm)	47.5 feet (14478 mm)

1133B.5.3.1 The cross slope of ramp surfaces shall be no greater than one unit vertical in 50 units horizontal (2-percent slope).

1133B.5.4 Landings. Level ramp landings shall be installed as follows:

1133B.5.4.1 Location of landings. Level ramp landings shall be provided at the top and bottom of each ramp. Intermediate landings shall be provided at intervals not exceeding 30 inches (762 mm) of vertical rise and at each change of direction. Landings are not considered in determining the maximum horizontal distance of each ramp. Landings shall be level as specified in the definition of "Level area" in Section 1102B.

1133B.5.4.2 Size of top and bottom landings. Top landings shall be not less than 60 inches (1524 mm) wide and shall have a length of not less than 60 inches (1524 mm) in the direction of ramp run. Landings at the bottom of ramps shall have a dimension in the direction of ramp run of not less than 72 inches (1829 mm).

1133B.5.4.3 Encroachment of doors. Doors in any position shall not reduce the minimum dimension of the landing to less than 42 inches (1067 mm) and shall not reduce the required width by more than 3 inches (76 mm) when fully open. See Figure 11B-39(b).

1133B.5.4.4 Strike edge extension. The width of the landing shall extend 24 inches (610 mm) past the strike edge of any door or gate for exterior ramps and 18 inches (457 mm) past the strike edge for interior ramps.

1133B.5.4.5 Landing width. At bottom and intermediate landings, the width shall be at least the same as required for the ramps.

1133B.5.4.6 Change of direction. Intermediate and bottom landings at a change of direction in excess of 30 degrees shall have a dimension in the direction of ramp run of not less than 72 inches (1829 mm) to accommodate the handrail extension.

1133B.5.4.7 Other intermediate landings. Other intermediate landings shall have a dimension in the direction of ramp run of not less than 60 inches (1524 mm).

1133B.5.4.8 For existing ramps or ramps not covered by Section 1133B.5.4.1, landings shall be provided as set forth in Section 1133B.5.4.1.

1133B.5.4.9 Hazards. Required ramps shall have a curb at least 2 inches (51 mm) high, or a wheel guide rail 2 to 4 inches (51 to 102 mm) high on each side of the ramp landing that has a vertical drop exceeding 4 inches (102 mm) and that is not bounded by a wall or fence.

1133B.5.5 Handrails for ramps.

1133B.5.5.1 Handrails are required on ramps that provide access if the slope exceeds one unit vertical in 20 units horizontal (5-percent slope), except that at exterior door landings, handrails are not required on ramps less than 6 inches (152 mm) rise or 72 inches (1829 mm) in length. Handrails shall be placed on each side of each ramp, shall be continuous the full length of the ramp, shall be 34 to 38 inches (864 to 965 mm) above the ramp surface to the top of the handrails, shall extend a minimum of 1 foot (305 mm) beyond the top and bottom of the ramp and shall be parallel with the floor or ground surface. The inside handrail on switchback or dogleg ramps shall always be continuous. The ends of handrails shall be either rounded or returned smoothly to floor, wall or post. Handrails projecting from a wall shall have a space of 1½ inches (38 mm) between the wall and the handrail. Handrails may be located in a recess if the recess is a maximum of 3 inches (76 mm) deep and extends at least 18 inches (457 mm) above the top of the rail. The grip portion shall not be less than 1¼ inches (32 mm) nor more than 1½ inches (38 mm) in cross-sectional nominal dimension or the shape shall provide an equivalent gripping surface, and all surfaces shall be smooth with no sharp corners. Handrails shall not rotate within their fittings. Any wall or other surface adjacent to the handrail shall be free of sharp or abrasive elements. Edges shall have a minimum radius of 1/8 inch (3 mm).

Exceptions:

1. Handrails at ramps immediately adjacent to fixed seating in assembly areas are not required.
2. Curb ramps do not require handrails.

1133B.5.5.1.1 Ramp handrails. In existing buildings or facilities, where the extension of the handrail in the direction of the ramp run would create a hazard, the extension on the handrail may be turned 90 degrees to the run of the ramp.

1133B.5.6 Wheel guides. Where the ramp surface is not bounded by a wall, the ramp shall comply with Section 1133B.5.6.1 or 1133B.5.6.2.

1133B.5.6.1 A guide curb a minimum of 2 inches (51 mm) in height shall be provided at each side of the ramp; or

1133B.5.6.2 A wheel guide rail shall be provided, centered 3 inches (76 mm) plus or minus 1 inch (25 mm) above the surface of the ramp.

1133B.5.7 Guards. Ramps more than 30 inches (762 mm) above the adjacent ground shall be provided with guards that comply with Section 1013. Such guards shall be continuous from the top of the ramp to the bottom of the ramp.

1133B.5.8 Outdoor ramps. Outdoor ramps and their approaches shall be designed so that water will not accumulate on walking surfaces.

1133B.6 Aisles.

1133B.6.1 General. Every portion of every building in which are installed seats, tables, merchandise, equipment or similar materials shall be provided with aisles leading to an exit.

1133B.6.2 Width. Every aisle shall not be less than 36 inches (914 mm) wide if serving only one side, and not less than 44 inches (1118 mm) wide if serving both sides. In addition, aisles shall comply with Figure 11B-5E(a) and (b) for circulation around obstructions.

1133B.7 Walks and sidewalks.

1133B.7.1 Continuous surface. Walks and sidewalks subject to these regulations shall have a continuous common surface, not interrupted by steps or by abrupt changes in level exceeding ½ inch (12.7 mm) (see Section 1133B.7.4), and shall be a minimum of 48 inches (1219 mm) in width. If a walk or sidewalk has less than 60 inch (1525 mm) clear width, then passing spaces at least 60 inches by 60 inches (1525 mm by 1525 mm) shall be located at reasonable intervals not to exceed 200 feet (61 m). A T-intersection is an acceptable passing place. Surfaces shall be slip resistant as follows:

Exception: When, because of right-of-way restrictions, natural barriers or other existing conditions, the enforcing agency determines that compliance with the 48-inch (1219 mm) clear sidewalk width would create an unreasonable hardship, the clear width may be reduced to 36 inches (914 mm).

1133B.7.1.1 Slopes less than 6 percent. Surfaces with a slope of less than 6-percent slope shall be at least as slip resistant as that described as a medium salted finish.

1133B.7.1.2 Slopes 6 percent or greater. Surfaces with a slope of 6-percent slope shall be slip-resistant.

1133B.7.1.3 Surface cross slopes. Surface cross slopes shall not exceed one unit vertical in 50 units horizontal (2-percent slope).

1133B.7.2 Gratings. Walks, sidewalks and pedestrian ways shall be free of gratings whenever possible. For gratings located in the surface of any of these areas, grid openings in gratings shall be limited to ½ inch (12.7 mm) in the direction of traffic flow.

Exceptions:

1. Where the enforcing agency determines that compliance with this section would create an unreasonable hardship, an exception may be granted when equivalent facilitation is provided.
2. This section shall not apply in those conditions where, due to legal or physical constraints, the site of the project will not allow compliance with these building standards or equivalent facilitation without creating an unreasonable hardship. See Section 109.1.5.

1133B.7.3 Five-percent gradient. When the slope in the direction of travel of any walk exceeds one unit vertical in 20 units horizontal (5-percent slope), it shall comply with the provisions of Section 1133B.5.

1133B.7.4 Changes in level. Changes in level shall comply with Section 1124B.2.

1133B.7.5 Level areas. Walks shall be provided with a level area not less than 60 inches by 60 inches (1524 mm by 1524 mm) at a door or gate that swings toward the walk, and not less than 48 inches wide by 44 inches (1219 mm by 1118 mm) deep at a door or gate that swings away from the walk. Such walks shall extend 24 inches (610 mm) to the side of the strike edge of a door or gate that swings toward the walk. (For example, see Figure 11B-26B.)

1133B.7.6 Walks with continuous gradients. All walks with continuous gradients shall have level areas at least 5 feet (1524 mm) in length at intervals of 400 feet (121 920 mm) maximum.

1133B.8 Hazards.

1133B.8.1 Warning curbs. Abrupt changes in level, except between a walk or sidewalk and an adjacent street or driveway, exceeding 4 inches (102 mm) in a vertical dimension, such as at planters or fountains located in or adjacent to walks, sidewalks or other pedestrian ways, shall be identified by curbs projecting at least 6 inches (152 mm) in height above the walk or sidewalk surface to warn the blind of a potential drop off.

When a guard or handrail is provided, no curb is required when a guide rail is provided centered 3 inches (76 mm) plus or minus 1 inch (25 mm) above the surface of the walk or sidewalk, the walk is 5 percent or less gradient or no adjacent hazard exists.

1133B.8.2 Overhanging obstructions. Any obstruction that overhangs a pedestrian way shall be a minimum of 80 inches (2032 mm) above the walking surface as measured from the bottom of the obstruction. Where a guy support is used parallel to a path of travel, including, but not limited to sidewalks, a guy brace, sidewalk guy or similar device shall be used to prevent an overhanging obstruction as defined (see Figure 11B-28).

Hazards such as drop-offs adjacent to walkways or overhanging obstructions can be dangerous to persons with sight problems. This section addresses these situations.

1133B.8.3 Detectable warnings at transit boarding platforms. See Section 1121B.3.1, Item 8(a).

1133B.8.4 Detectable directional texture at boarding platforms. See Section 1121B.3.1, Item 8(b).

1133B.8.5 Detectable warnings at hazardous vehicular areas. If a walk crosses or adjoins a vehicular way, and the walking surfaces are not separated by curbs, railings or other elements between the pedestrian areas and vehicular areas, the boundary between the areas shall be defined by a continuous detectable warning which is 36 inches (914 mm) wide, complying with Section 1121B.3.1, Item 8(a).

Only approved DSA-AC detectable warning products and directional surfaces shall be installed as provided in the California Code of Regulations (CCR), Title 24, Part 1, Articles 2, 3 and 4. Refer to CCR Title 24, Part 12, Chapters 12-11A and B, for building and facility access specifications for product approval for detectable warning products and directional surfaces.

Detectable warning products and directional surfaces installed after January 1, 2001, shall be evaluated by an independent entity, selected by the Department of General Services, Division of the State Architect—Access Compliance, for all occupancies, including transportation and other outdoor environments, except that when products and surfaces are for use in residential housing, evaluation shall be in consultation with the Department of Housing and Community Development. See Government Code Section 4460.

1133B.8.6 Protruding objects.

1133B.8.6.1 General. Objects projecting from walls (for example, telephones), with their leading edges between 27 inches (686 mm) and 80 inches (2032 mm) above the finished floor, shall protrude no more than 4 inches (102 mm) into walks, halls, corridors, passageways or aisles. Objects mounted with their leading edges at or below 27 inches (686 mm) above the finished floor may protrude any amount. Free-standing objects mounted on posts or pylons may overhang 12 inches (305 mm) maximum from 27 inches (686 mm) to 80 inches (2032 mm) above the ground or finished floor. Protruding objects shall not reduce the clear width of an accessible route or maneuvering space. See Figure 11B-7A.

1133B.8.6.2 Head room. Walks, halls, corridors, passageways, aisles or other circulation spaces shall have 80 inches (2032 mm) minimum clear head room. If vertical clearance of an area adjoining an accessible route is reduced to less than 80 inches (nominal dimension), a barrier to warn blind or visually impaired persons shall be provided. See Figures 11B-7A and 11B-7C.

1133B.8.6.3 Free-standing signs. Wherever signs mounted on posts or pylons protrude from the posts or pylons and the bottom edge of the sign is at less than 80 inches (2032 mm) above the finished floor or ground level, the edges of such signs shall be rounded or eased and the corners shall have a minimum radius of 0.125 inches (3.2 mm).

1133B.8.7 Detectable warnings at reflecting pools. The edges of reflecting pools shall be protected by railings, walls, warning curbs or detectable warnings complying with Section 1121B.3.1, Item 8(a).

Division IV—ACCESSIBILITY FOR EXISTING BUILDINGS

SECTION 1134B

ACCESSIBILITY FOR EXISTING BUILDINGS

1134B.1 Scope. The provisions of this division apply to renovation, structural repair, alteration and additions to existing buildings, including those identified as historic buildings. This division identifies minimum standards for removing architectural barriers, and providing and maintaining accessibility to existing buildings and their related facilities.

No renovation, structural repair, alteration or addition shall be undertaken which decreases or has the effect of decreasing accessibility or usability of a building or facility below the requirements for new construction at the time of renovation, structural repair, alteration or addition.

1134B.2 General. All existing buildings and facilities, when alterations, structural repairs or additions are made to such buildings or facilities, shall comply with all provisions of Division I—New Buildings, except as modified by this division. These requirements shall apply only to the area of specific alteration, structural repair or addition and shall include those areas listed below:

1134B.2.1 A primary entrance to the building or facility and the primary path of travel to the specific area of alteration, structural repair or addition, and sanitary facilities, drinking fountains, signs and public telephones serving the area.

Exceptions:

1. When the total construction cost of alterations, structural repairs or additions does not exceed a valuation threshold of \$50,000, based on January 1981, "ENR US20 Cities" Average Construction Cost Index of 3372.02 (Engineering News Record, McGraw Hill Publishing Company), and the enforcing agency finds that compliance with this code creates an unreasonable hardship, compliance shall be limited to the actual work of the project. The enforcing agency shall annually update the valuation threshold to a current amount based on the increase in the index since the last figure used. (For example, the January 2008 amount is \$119,958.65.) For purposes of this exception, an unreasonable hardship exists where the cost of providing an accessible entrance, path of travel, sanitary facilities, public phones and drinking fountains is disproportionate to the cost of the project; that is, where it exceeds 20 percent of the cost of the project without these features. Where the cost of alterations necessary to make these features fully accessible is disproportionate, access shall be provided to the extent that it can be without incurring disproportionate cost. In choosing which accessible elements to provide, priority should be given to those elements that will provide the greatest access in the following order:

- 1.1. An accessible entrance;
- 1.2. An accessible route to the altered area;
- 1.3. At least one accessible restroom for each sex;

- 1.4. Accessible telephones;
- 1.5. Accessible drinking fountains; and
- 1.6. When possible, additional accessible elements such as parking, storage and alarms.

The obligation to provide access may not be evaded by performing a series of small alterations to the area served by a single path of travel if those alterations could have been performed as a single undertaking. If an area has been altered without providing an accessible path of travel to that area, and subsequent alterations of that area or a different area on the same path of travel are undertaken within three years of the original alteration, the total cost of alterations to the areas on that path of travel during the preceding three-year period shall be considered in determining whether the cost of making that path of travel accessible is disproportionate. Only alterations undertaken after January 26, 1992, shall be considered in determining if the cost of providing an accessible path of travel is disproportionate to the overall cost of the alterations.

2. Certain types of privately funded, multistory buildings and facilities were formerly exempt from accessibility requirements above and below the first floor under this code, but as of the effective date of this regulation are no longer exempt due to more restrictive provisions in the federal Americans with Disabilities Act. In alteration projects involving buildings and facilities previously approved and built without elevators, areas above and below the ground floor are subject to the 20-percent disproportionality provisions described in Exception 1, above, even if the value of the project exceeds the valuation threshold in Exception 1. The types of buildings and facilities are:

- 2.1. Office buildings and passenger vehicle service stations of three stories or more and 3,000 or more square feet (279 m²) per floor.
- 2.2. Offices of physicians and surgeons.
- 2.3. Shopping centers.
- 2.4. Other buildings and facilities three stories or more and 3,000 or more square feet (279 m²) per floor if a reasonable portion of services sought and used by the public is available on the accessible level.

For the general privately funded multistory building exception applicable to new construction and alterations, see Section 1103B.1, Exception 2.

The elevator exception set forth in this section does not obviate or limit in any way the obligation to comply with the other accessibility requirements in this code. For example, floors above or below the accessible ground floor must meet the requirements of this section except for elevator service. If toilet or bathing facilities are provided on a level not served by an elevator, then toilet or bathing facilities must be provided on the accessible ground floor.

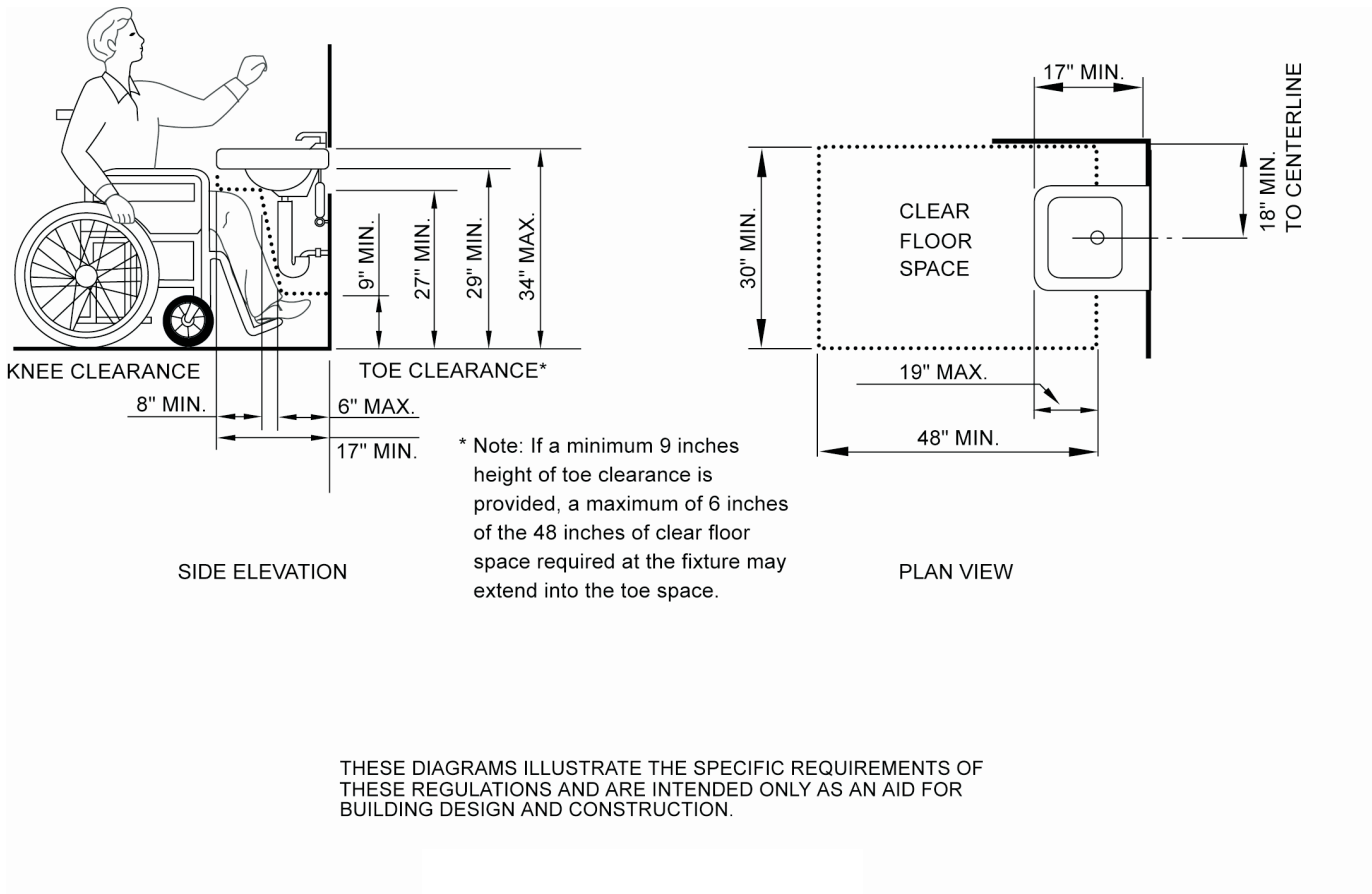
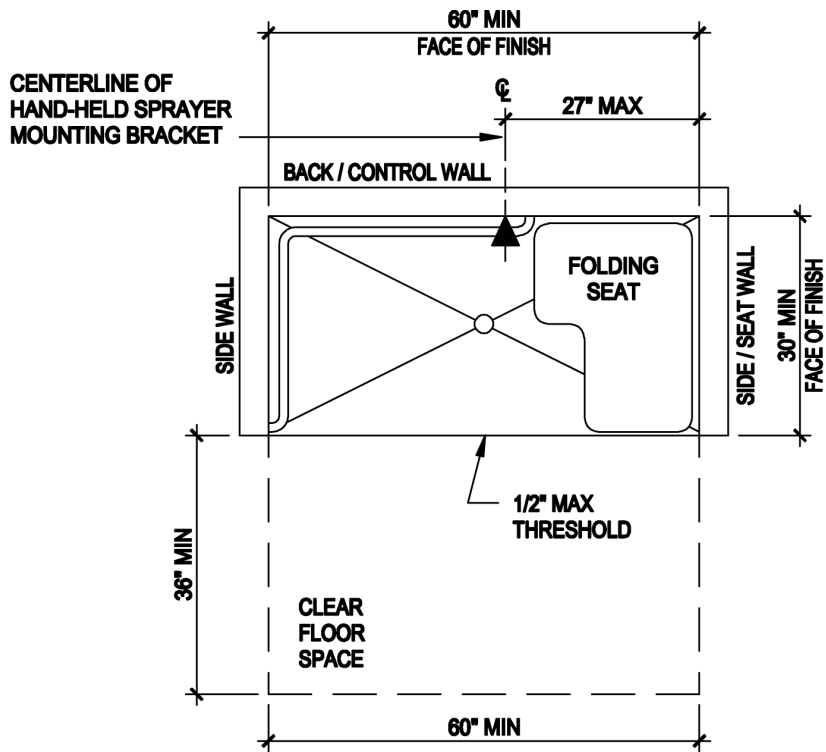
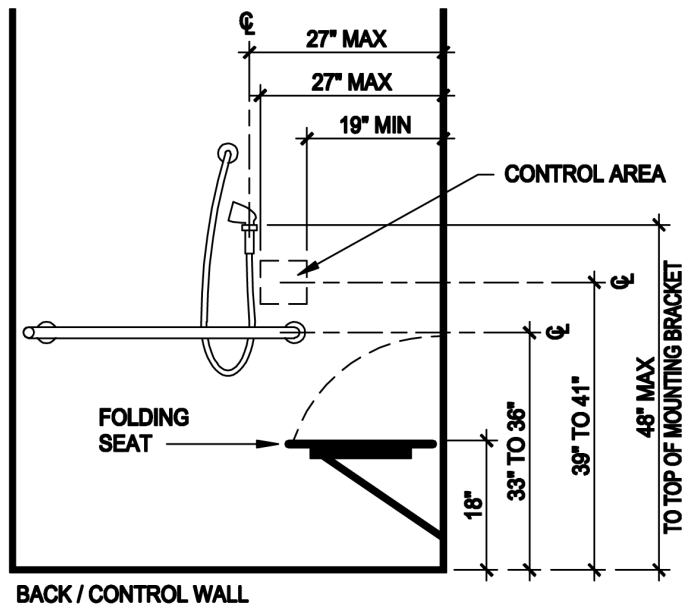

FIGURE 11B-1D—KNEE CLEARANCE



(a) 60" MINIMUM X 30" MINIMUM ROLL-IN SHOWER



(b) ELEVATION - 60" MINIMUM X 30" MINIMUM ROLL-IN SHOWER

FIGURE 11B-2A—SHOWER STALLS

(continued)

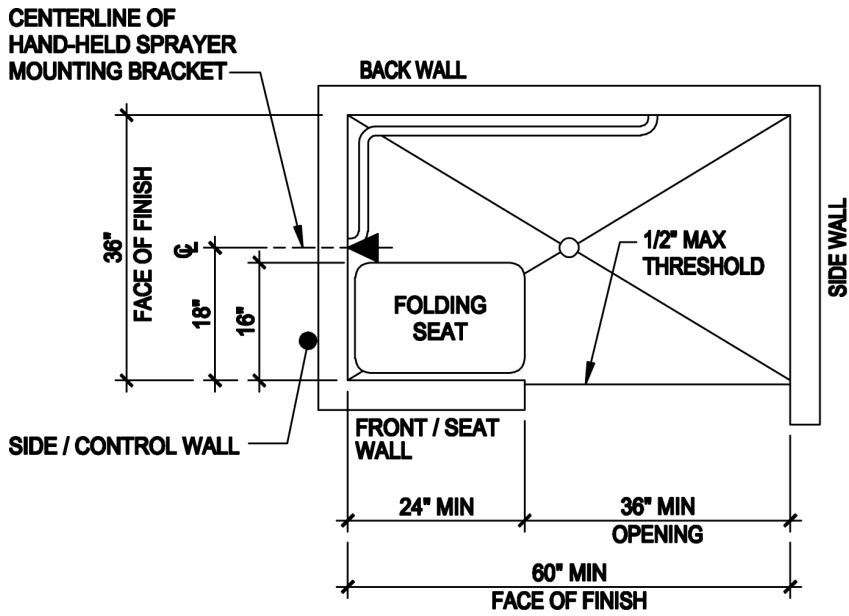

(a) 60" MINIMUM X 36" ALTERNATE ROLL-IN SHOWER

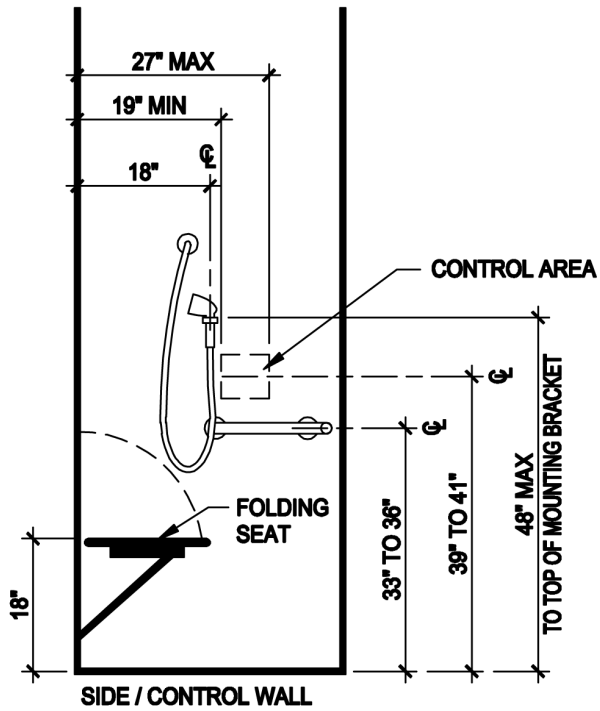

(b) ELEVATION - 60" MINIMUM X 36" ALTERNATE ROLL-IN SHOWER

FIGURE 11B-2B—SHOWER STALLS—continued

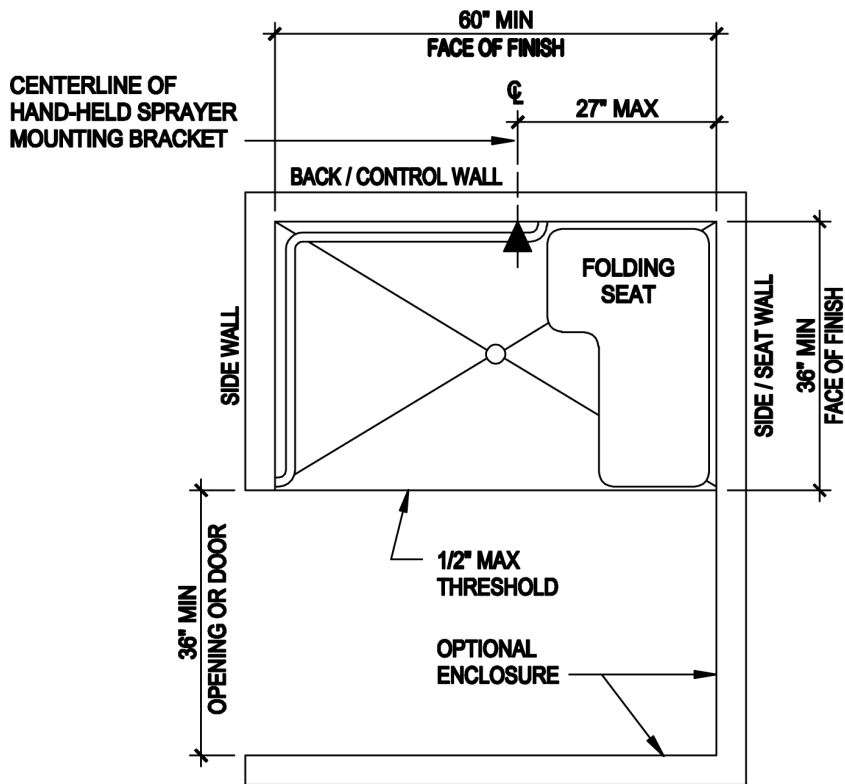

(a) 60" MINIMUM X 36" MINIMUM ALTERNATE ROLL-IN SHOWER WITH OPTIONAL ENCLOSURE

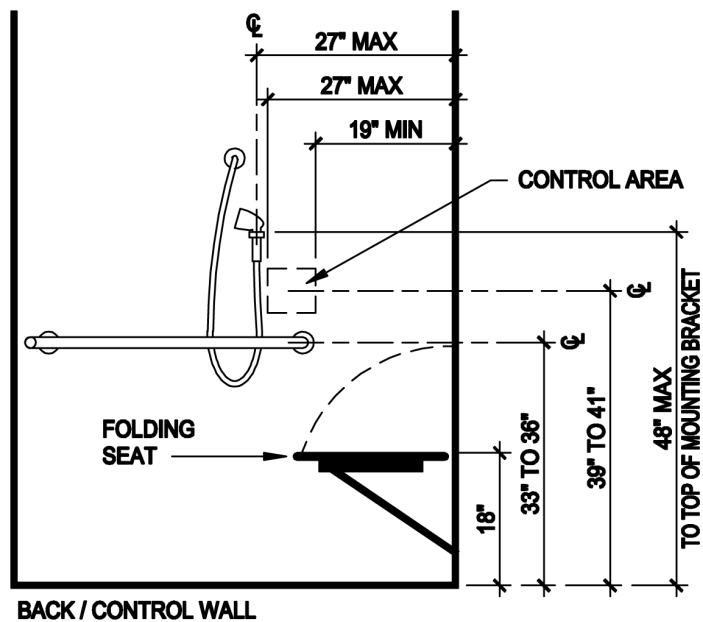

(b) ELEVATION - 60" MINIMUM X 36" MINIMUM ALTERNATE ROLL-IN SHOWER WITH OPTIONAL ENCLOSURE

FIGURE 11B-2C—SHOWER STALLS—continued

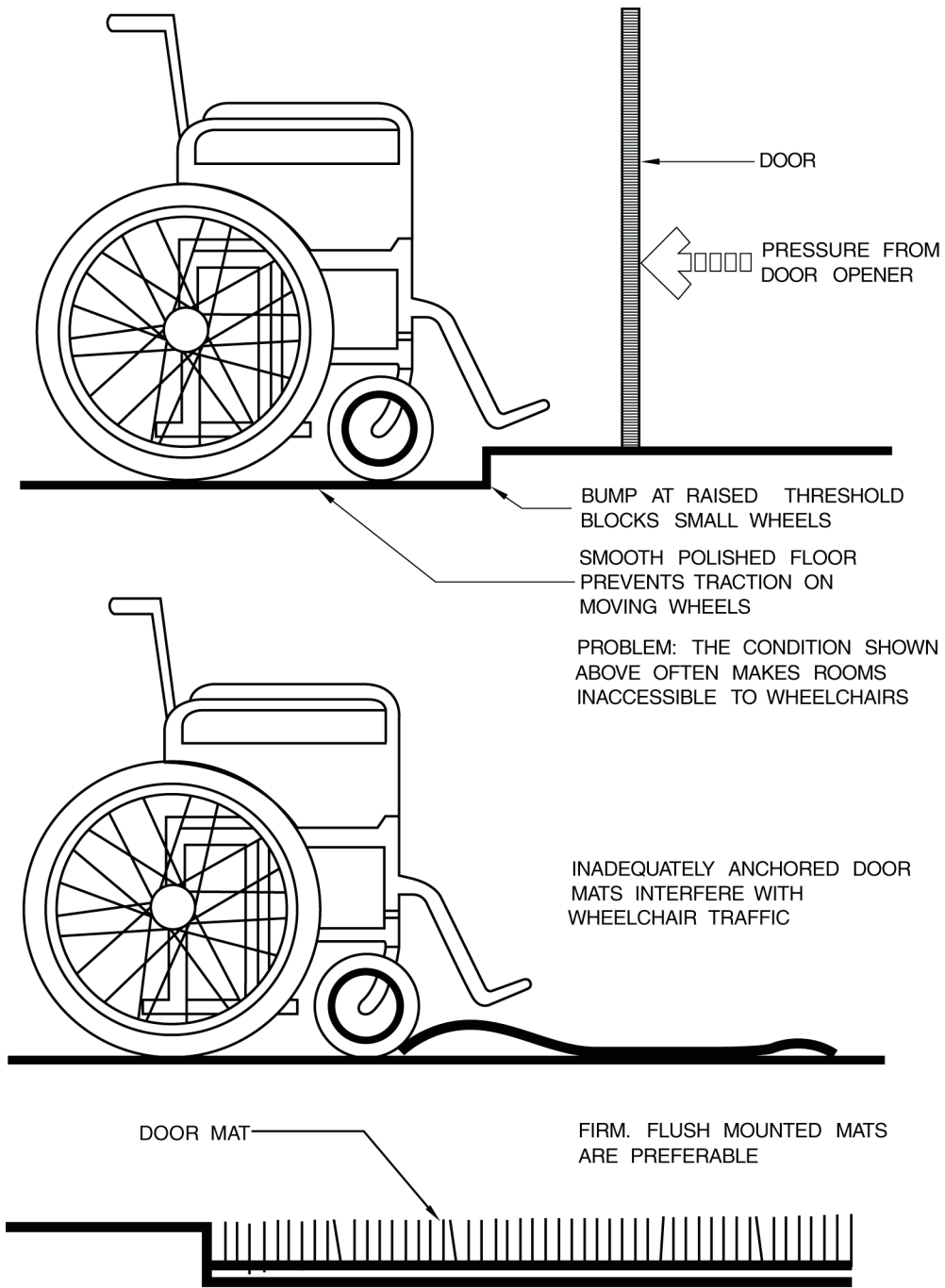

THESE DIAGRAMS ILLUSTRATE THE SPECIFIC REQUIREMENTS OF THESE REGULATIONS AND ARE INTENDED ONLY AS AN AID FOR BUILDING DESIGN AND CONSTRUCTION.

FIGURE 11B-25—OBSTRUCTIONS

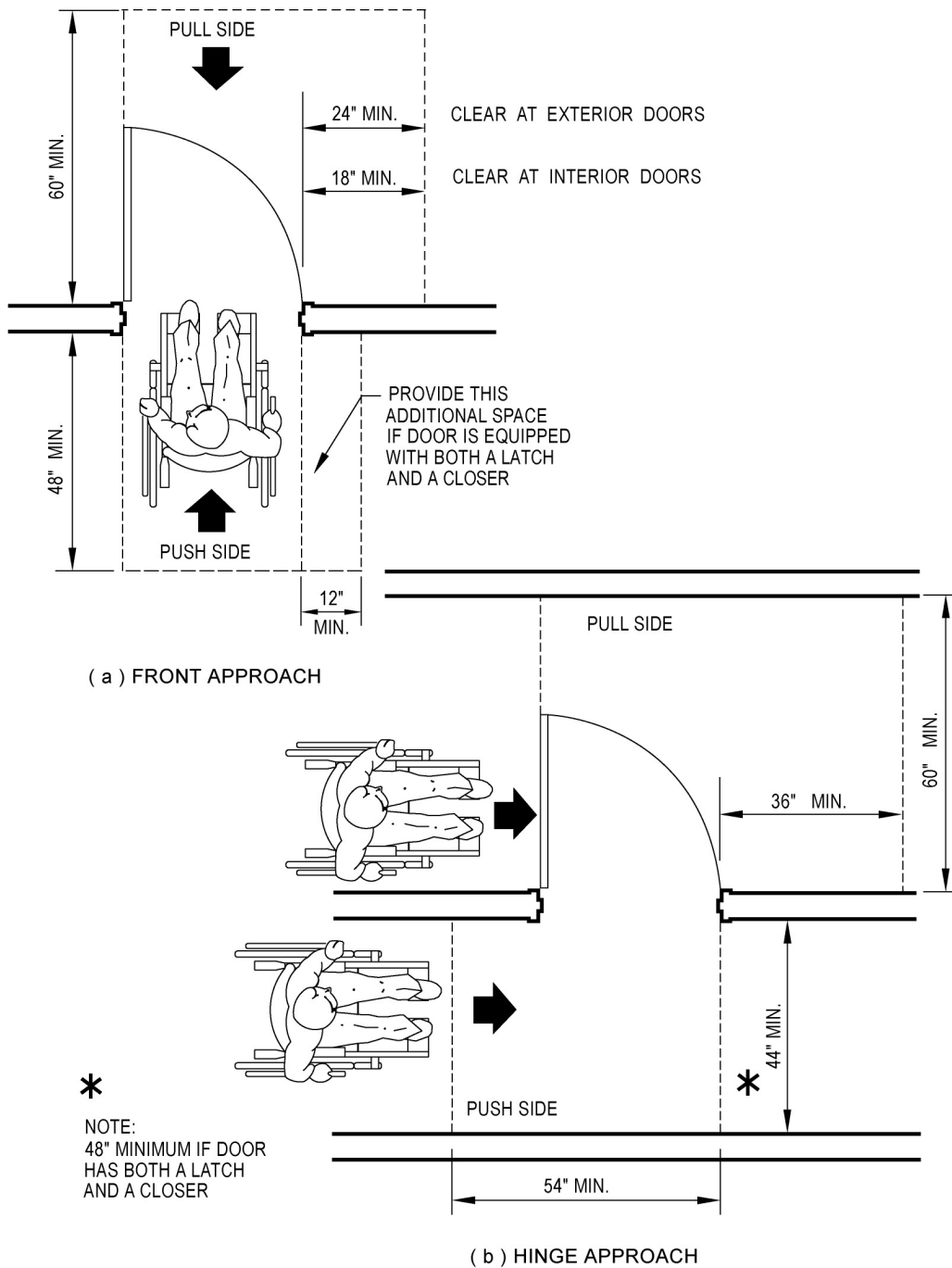

* NOTE: ALL DOORS IN ALCOVES SHALL COMPLY WITH THE CLEARANCES FOR FRONT APPROACHES.

THESE DIAGRAMS ILLUSTRATE THE SPECIFIC REQUIREMENTS OF THESE REGULATIONS AND ARE INTENDED ONLY AS AN AID FOR BUILDING DESIGN AND CONSTRUCTION.

FIGURE 11B-26A—LEVEL MANEUVERING CLEARANCE AT DOORS

(continued)

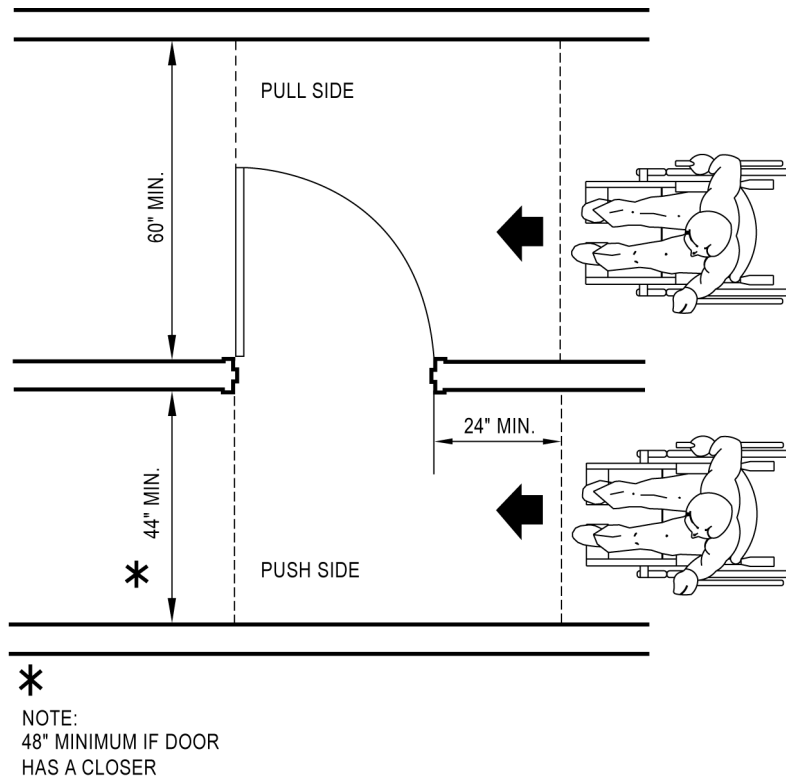

(c) LATCH APPROACH

* NOTE: ALL DOORS IN ALCOVES SHALL COMPLY WITH THE CLEARANCES FOR FRONT APPROACHES.

THIS DIAGRAM ILLUSTRATES THE SPECIFIC REQUIREMENTS OF THESE REGULATIONS AND IS INTENDED ONLY AS AN AID FOR BUILDING DESIGN AND CONSTRUCTION.

FIGURE 11B-26B—LEVEL MANEUVERING CLEARANCE AT DOORS—continued

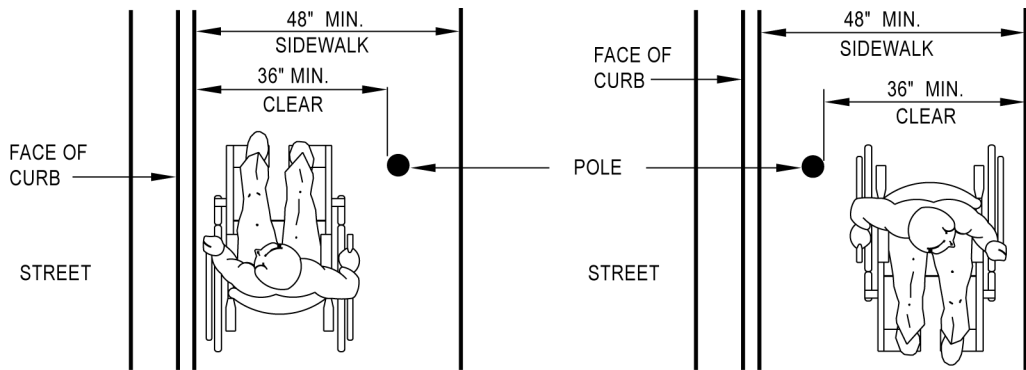

(a) SIDEWALK OBSTRUCTIONS

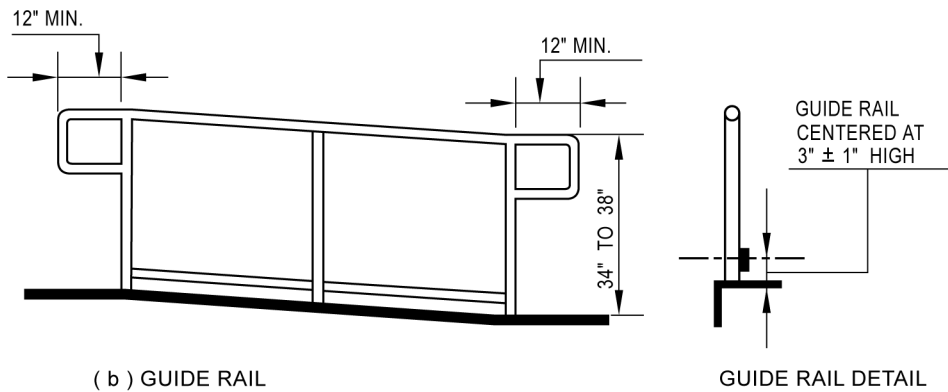

(b) GUIDE RAIL

GUIDE RAIL DETAIL

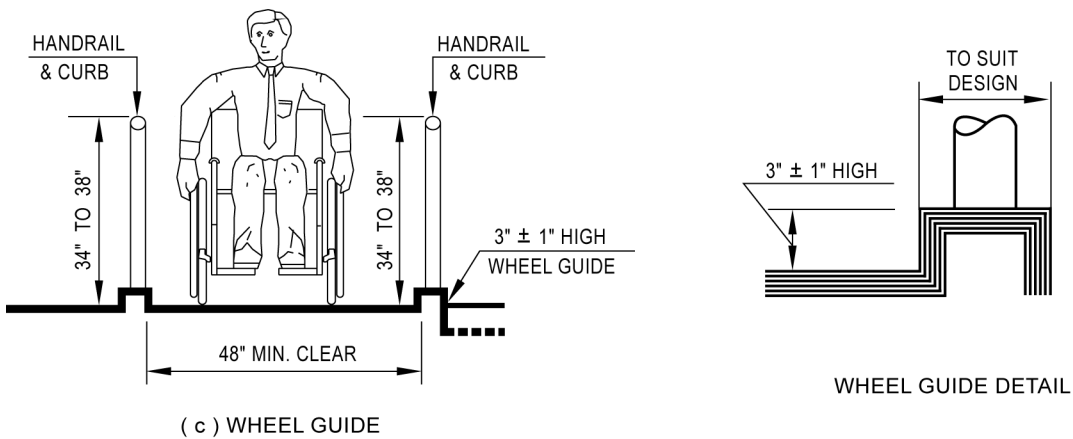

(c) WHEEL GUIDE

WHEEL GUIDE DETAIL

THESE DIAGRAMS ILLUSTRATE THE SPECIFIC REQUIREMENTS OF THESE REGULATIONS AND ARE INTENDED ONLY AS AN AID FOR BUILDING DESIGN AND CONSTRUCTION.

FIGURE 11B-27—RAMPS AND SIDEWALKS

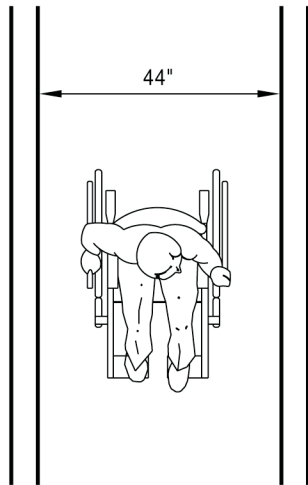

MINIMUM CORRIDOR WIDTH

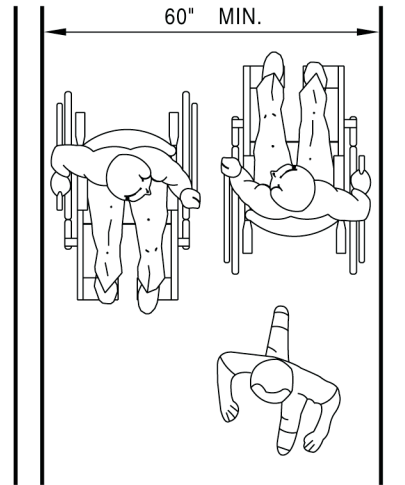

MINIMUM WIDTH FOR
CORRIDORS OVER 200

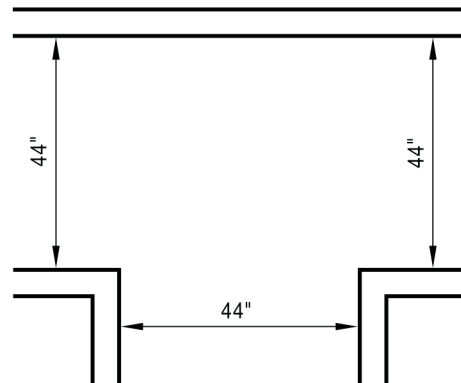
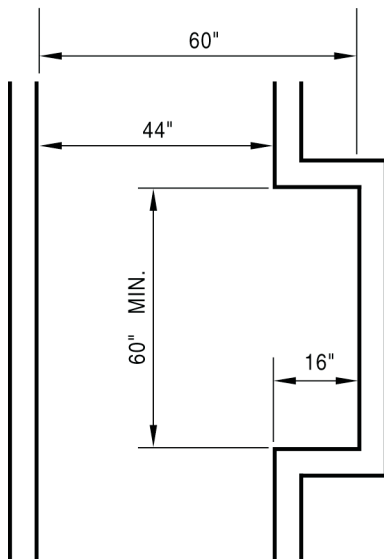

PASSING ALCOVES FOR CORRIDORS OVER
200' IN LIEU OF 60" MIN. WIDTH

THESE DIAGRAMS ILLUSTRATE THE SPECIFIC REQUIREMENTS OF THESE REGULATIONS AND ARE INTENDED ONLY AS AN AID FOR BUILDING DESIGN AND CONSTRUCTION.

FIGURE 11B-34—CORRIDOR OVER 200 FEET (60 960 mm)

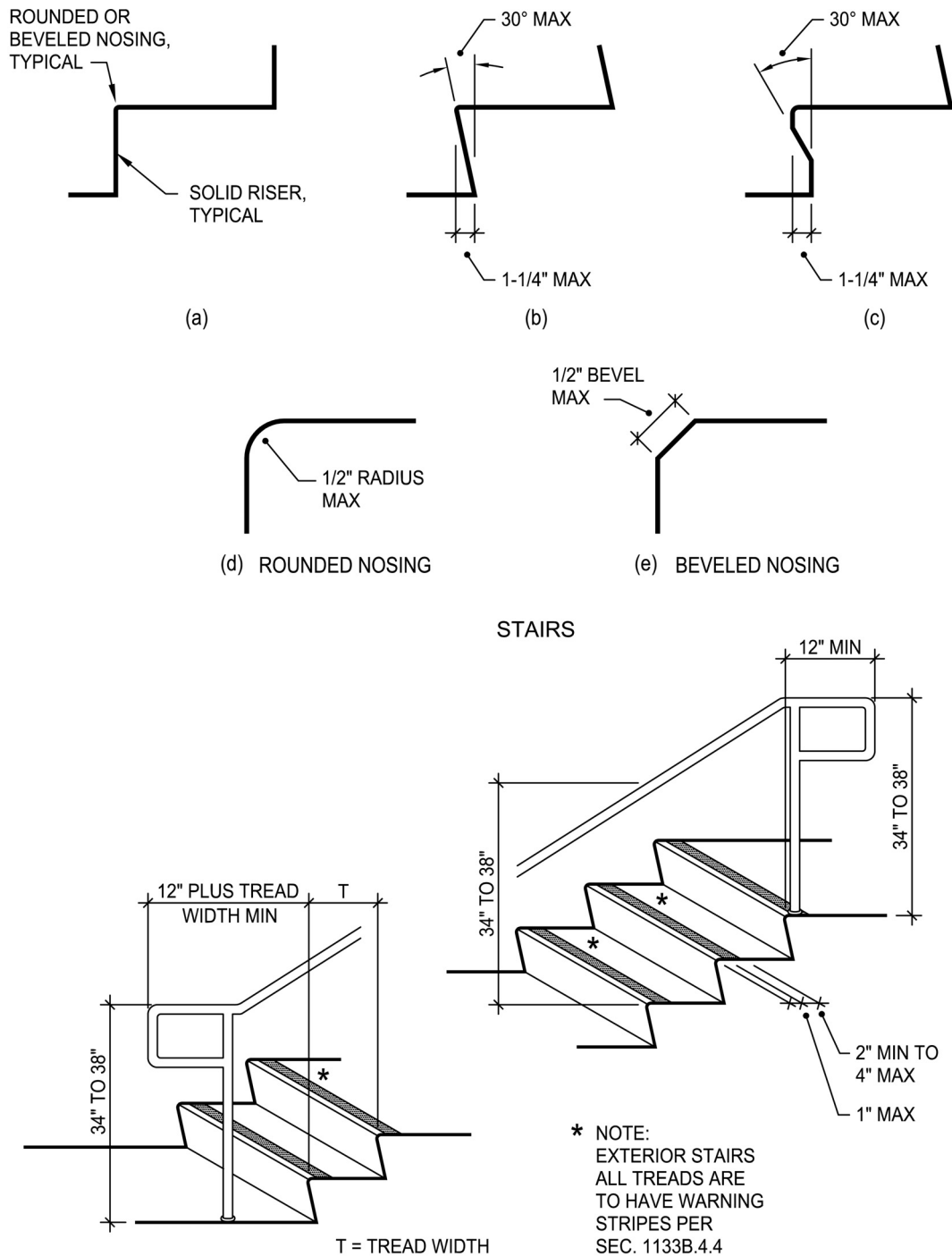

THESE DIAGRAMS ILLUSTRATE THE SPECIFIC REQUIREMENTS OF THESE REGULATIONS AND ARE INTENDED ONLY AS AN AID FOR BUILDING DESIGN AND CONSTRUCTION

FIGURE 11B-35—WARNING STRIPING AND HANDRAIL EXTENSIONS

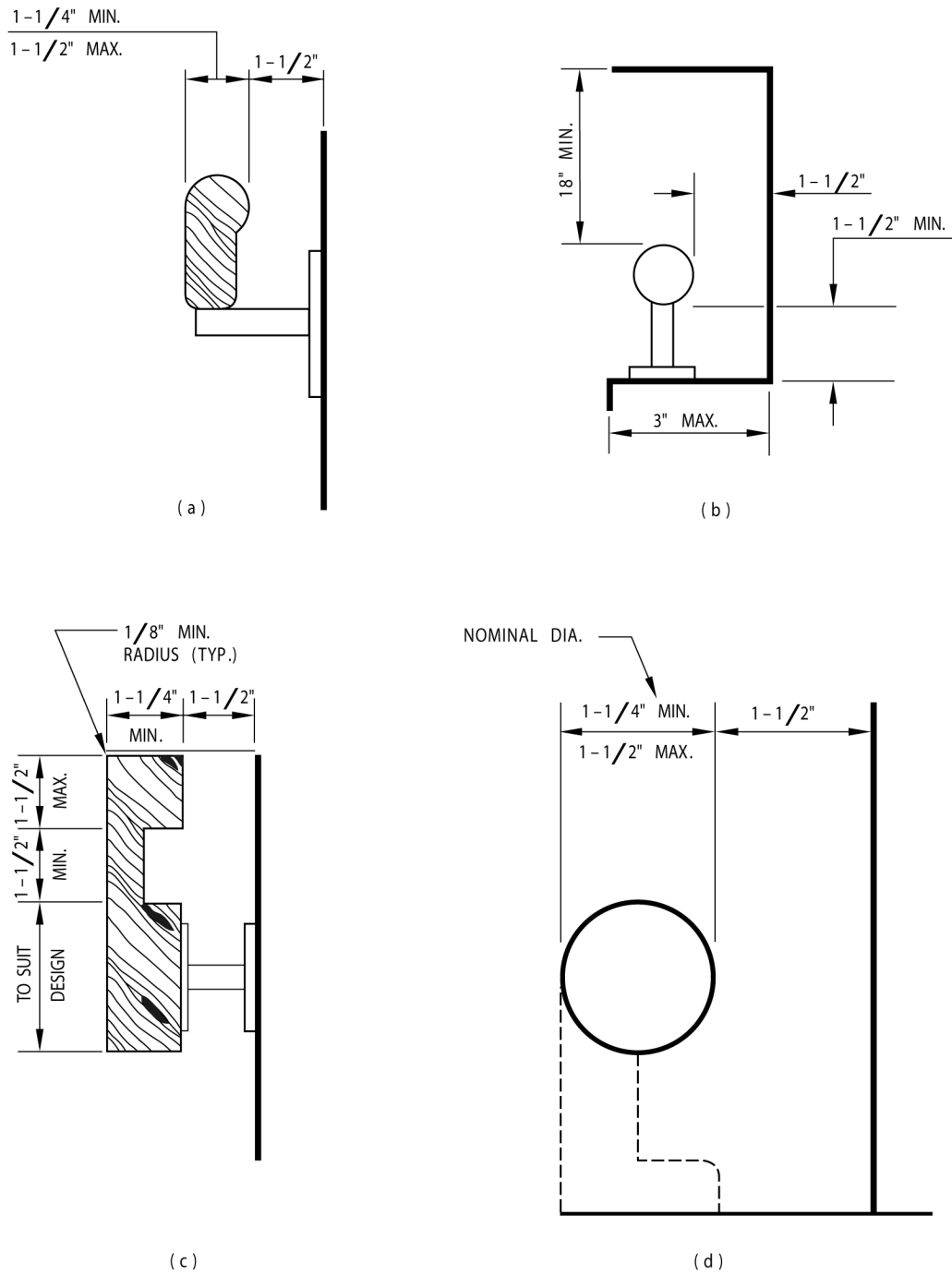

THESE DIAGRAMS ILLUSTRATE THE SPECIFIC REQUIREMENTS OF THESE REGULATIONS AND ARE INTENDED ONLY AS AN AID FOR BUILDING DESIGN AND CONSTRUCTION.

FIGURE 11B-36—STAIR HANDRAILS

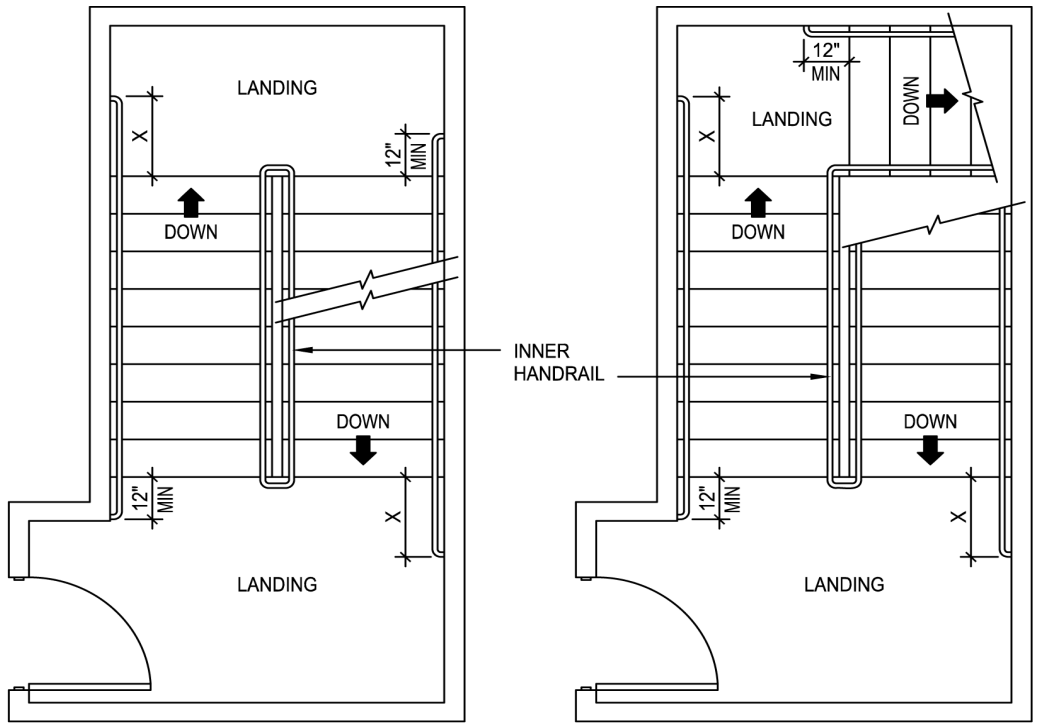

NOTE: INNER HANDRAIL AT LANDINGS OF STAIRS THAT DOUBLE BACK OR IMMEDIATELY TURN SHALL BE CONTINUOUS AND SHALL NOT EXTEND INTO LANDING OR ACCESSIBLE ROUTE OF TRAVEL

X = EXTENSION OF HANDRAIL SHALL BE EQUAL TO THE TREAD WIDTH PLUS 12 INCHES MINIMUM

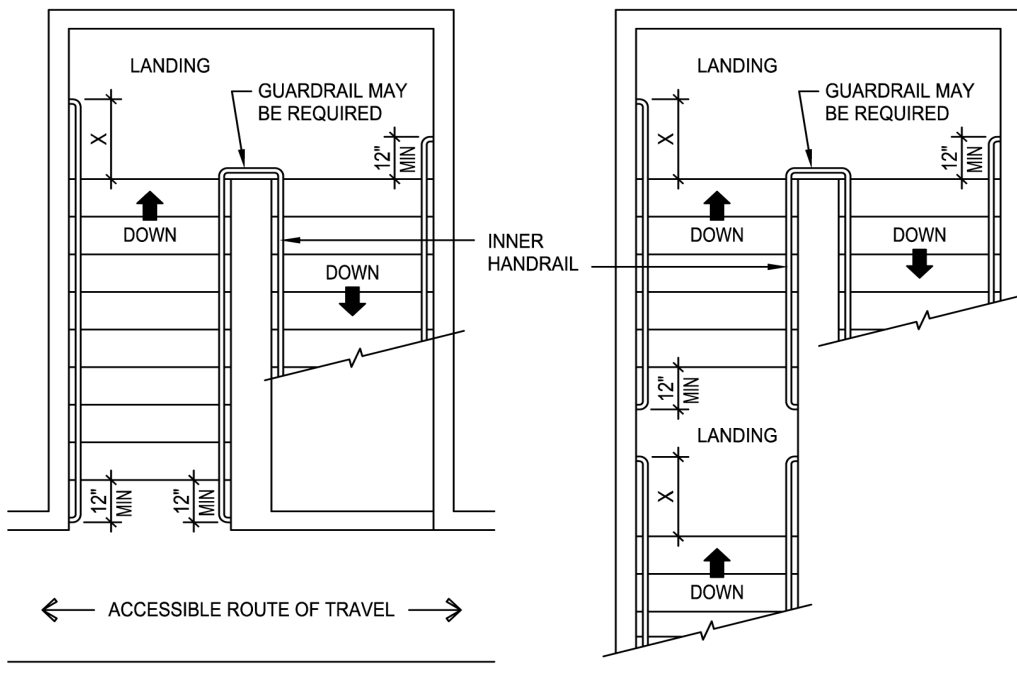

← ACCESSIBLE ROUTE OF TRAVEL →

THESE DIAGRAMS ILLUSTRATE THE SPECIFIC REQUIREMENTS OF THESE REGULATIONS AND ARE INTENDED ONLY AS AN AID FOR BUILDING DESIGN AND CONSTRUCTION

FIGURE 11B-37—STAIR HANDRAILS

CHAPTER 11C

STANDARDS FOR CARD READERS AT GASOLINE FUEL-DISPENSING FACILITIES

SECTION 1101C CARD-READER DEVICES AT FUEL-DISPENSING EQUIPMENT

1101C.1 General. Notwithstanding other requirements in the California Building Code, only the requirements and additional definitions in this section shall apply to card-reading devices in motor vehicle fuel facilities, except that administrative requirements which are found in Chapter 1 still apply.

For purposes of this section, the following additional definitions shall apply:

ACCESSIBLE. See Chapter 11A, Section 1107A.1-A and Chapter 11B, Section 1102B.

ACCESSIBLE ELEMENT. See Chapter 11B, Section 1102B.

ALTERNATE CARD READER shall be defined in this section as functionally equal card reader and control directly attached to or an integral part of the fuel dispenser in addition to the primary card reader, which is an integral part of the dispenser.

FREE-STANDING PEDESTAL is a card-reading device which controls one or more remote fuel dispensers that have no card readers as an integral part of the fuel dispenser.

GRADE (Adjacent Ground Elevation). See Chapter 2, Section 202.

INTERNATIONAL SYMBOL OF ACCESSIBILITY. See Chapter 11A, Section 1107A.9-I and Chapter 11B, Section 1102B.

LEVEL ACCESSIBLE AREA, for the purpose of this section, shall mean a slope of not more than one unit vertical in 50 units horizontal (2-percent slope) in front of the dispensing device; however, the slope may extend to one unit vertical in 20 units horizontal (5-percent slope) where the enforcing authority determines that, due to unusual site conditions, the 2-percent slope is not obtainable.

LEVEL AREA. See Chapter 11A, Section 1107A.12-L and Chapter 11B, Section 1102B.

PATH OF TRAVEL shall include the clearance requirements stated in Chapter 11B for wheelchair passage widths, and relationships of maneuvering clearances to wheelchair spaces, except that pump nozzles and hoses may overlap required clearances.

RECOMMEND. See Chapter 2, Section 202.

TYPE OF MOTOR FUEL shall mean gasoline, diesel, compressed natural gas, methanol, electricity or ethanol.

SECTION 1102C APPLICATION

This section shall apply to equipment located at the following facilities:

1. New motor vehicle fuel facilities.
2. Existing motor vehicle fuel facilities built before the effective date of this section where:
 - 2.1. Remodeling or reconstruction includes removal and replacement of one or more islands and associated piping and tank(s); or
 - 2.2. Remodeling includes reconstruction or removal and replacement of fuel islands at facilities that provide free-standing pedestal card readers.

SECTION 1103C NUMBER OF ACCESSIBLE CARD-READING DEVICES REQUIRED

Where only one card-reading device is installed for use with any type of motor fuel, it shall meet the required features of this section. When more than one card-reading location is available for a specific type of motor fuel, a minimum of two for that type shall have the accessible features of this section.

SECTION 1104C REQUIRED FEATURES

Card-reading devices at motor vehicle fuel facilities shall be accessible by complying with only the following:

1. The highest operable part of each primary or alternate card reader shall be no more than 54 inches (1372 mm) measured from the base of the fuel dispenser. Where card readers are located on free-standing pedestals, the card-reading control function shall be no more than 54 inches (1372 mm) above an accessible level area which is served by an accessible path of travel.

Exception: If an enforcing agency requires that fuel dispensers or card-reading devices be placed in a manner where the card-reading device exceeds the requirements described herein, the provisions of Section 1104C do not apply. Any enforcing agency having jurisdiction over retail fueling facilities may not require islands or impose other regulations which conflict with this section, unless the agency documents and justifies the specific necessity for such a rule or ordinance and complies with the requirements of Health and Safety Code Section 18941.

2. An accessible path of travel shall be provided to the base of all fuel dispensers required to meet the provisions of

this section. Such fuel dispensers shall be mounted on the accessible level area.

3. *An accessible level area shall be provided, which is minimally 30 inches by 48 inches (762 mm by 1219 mm) level and clear. This area shall be provided within 10 inches (254 mm) in plan view of the face of the controls and shall be unobstructed by any features, except pump nozzles and hoses, with the long side of this space parallel to and centered [plus or minus 9 inches (229 mm)] with the face of the card-reader controls. See Figures 11C-1 and 11C-2.*

**SECTION 1105C
PROTECTION OF DISPENSERS
MOUNTED AT GRADE**

Dispensers mounted at grade shall be protected from vehicular damage as required by Part 9, Title 24 (California Fire Code).

CALIFORNIA BUILDING CODE – MATRIX ADOPTION TABLE CHAPTER 12 – INTERIOR ENVIRONMENT

Adopting Agency	BSC	SFM	HCD			DSA		OSHPD				CSA	DHS	AGR	DWR	CEC	CA	SL	SLC
			1	2	1/AC	AC	SS	1	2	3	4								
Adopt Entire Chapter							X ◆												
Adopt Entire Chapter as amended (amended sections listed below)	X	X						X	X	X	X								
Adopt only those sections that are listed below			X ◆	X ◆								X	X	X		X	X		
Chapter / Section	Codes																		
1203.1	CA							X	X	X	X								
1203.3.1.1	CA																	X	
1203.3.2	IBC		X	X															
1203.3.2 Item 4	CA															X			
1203.3.2 Exc. 6	CA																X		
1203.4	IBC		X	X															
1203.5	IBC		X	X															
1203.5	CA	X																	
1204.1w/Excs.	CA		X	X				X	X	X	X								
1205.1	IBC		X	X															
1205.6	CA	X																	
1207	CA		X																
1208.1	IBC		X																
1208.2	CA							X	X	X	X								
1208.2.1	CA							X	X	X	X								
1208.4	IBC		X																
1209.1.1	CA																	X	
1211	CA		X	X															
1224	CA							X											
1225	CA								X										
1226	CA									X									
1227	CA										X								
1230	CA											X							
1231	CA											X							
1235	CA												X						
1236	CA												X						
1237	CA												X						
1240	CA													X					
1241	CA													X					
1242	CA													X					
1243	CA													X					
1250	CA																	X	
1251	CA																	X	
1252	CA																	X	
1253	CA																	X	
1254	CA																	X	

The ◆ designation indicates that the Office of the State Fire Marshal's adoption of this chapter or individual sections is applicable to structures subject to HCD 1 and/or HCD 2 or DSA-SS.

CHAPTER 12

INTERIOR ENVIRONMENT

SECTION 1201 GENERAL

1201.1 Scope. The provisions of this chapter shall govern ventilation, temperature control, lighting, yards and courts, sound transmission, room dimensions, surrounding materials and rodent proofing associated with the interior spaces of buildings.

SECTION 1202 DEFINITIONS

1202.1 General. The following words and terms shall, for the purposes of this chapter and as used elsewhere in this code, have the meanings shown herein.

SUNROOM ADDITION. A one-story addition added to an existing building with a glazing area in excess of 40 percent of the gross area of the structure's exterior walls and roof.

THERMAL ISOLATION. A separation of conditioned spaces, between a sunroom addition and a dwelling unit, consisting of existing or new wall(s), doors and/or windows.

SECTION 1203 VENTILATION

1203.1 General. Buildings shall be provided with natural ventilation in accordance with Section 1203.4, or mechanical ventilation in accordance with the *California Mechanical Code*.

Exception: [OSHPD 1, 2, 3 & 4] For restrictions on natural ventilation, see California Mechanical Code.

1203.2 Attic spaces. Enclosed attics and enclosed rafter spaces formed where ceilings are applied directly to the underside of roof framing members shall have cross ventilation for each separate space by ventilating openings protected against the entrance of rain and snow. Blocking and bridging shall be arranged so as not to interfere with the movement of air. A minimum of 1 inch (25 mm) of airspace shall be provided between the insulation and the roof sheathing. The net free ventilating area shall not be less than $1/150$ of the area of the space ventilated, with 50 percent of the required ventilating area provided by ventilators located in the upper portion of the space to be ventilated at least 3 feet (914 mm) above eave or cornice vents with the balance of the required ventilation provided by eave or cornice vents.

Exception: The minimum required net free ventilating area shall be $1/300$ of the area of the space ventilated, provided a vapor retarder having a transmission rate not exceeding 1 perm in accordance with ASTM E 96 is installed on the warm side of the attic insulation and provided 50 percent of the required ventilating area provided by ventilators located in the upper portion of the space to be ventilated at least 3 feet (914 mm) above eave or cornice vents, with the balance

of the required ventilation provided by eave or cornice vents.

1203.2.1 Openings into attic. Exterior openings into the attic space of any building intended for human occupancy shall be covered with corrosion-resistant wire cloth screening, hardware cloth, perforated vinyl or similar material that will prevent the entry of birds, squirrels, rodents, snakes and other similar creatures. The openings therein shall be a minimum of $1/8$ inch (3.2 mm) and shall not exceed $1/4$ inch (6.4 mm). Where combustion air is obtained from an attic area, it shall be in accordance with Chapter 7 of the *California Mechanical Code*.

1203.3 Under-floor ventilation. The space between the bottom of the floor joists and the earth under any building except spaces occupied by a basement or cellar shall be provided with ventilation openings through foundation walls or exterior walls. Such openings shall be placed so as to provide cross ventilation of the under-floor space.

1203.3.1 Openings for under-floor ventilation. The minimum net area of ventilation openings shall not be less than 1 square foot for each 150 square feet (0.67 m² for each 100 m²) of crawl-space area. Ventilation openings shall be covered for their height and width with any of the following materials, provided that the least dimension of the covering shall not exceed $1/4$ inch (6 mm):

1. Perforated sheet metal plates not less than 0.070 inch (1.8 mm) thick.
2. Expanded sheet metal plates not less than 0.047 inch (1.2 mm) thick.
3. Cast-iron grilles or gratings.
4. Extruded load-bearing vents.
5. Hardware cloth of 0.035 inch (0.89 mm) wire or heavier.
6. Corrosion-resistant wire mesh, with the least dimension not exceeding $1/8$ inch (3.2 mm).

1203.3.1.1 [SPCB] Openings for under-floor ventilation shall be not less than $1\ 1/2$ square feet (0.135 m²) for each 25 linear feet (7620 linear mm) of exterior wall. They shall be covered with corrosion-resistant wire mesh with mesh openings not less than $1/4$ inch (6.4 mm) nor more than $1/2$ inch (13 mm) in any dimension.

1203.3.2 Exceptions. The following are exceptions to Sections 1203.3 and 1203.3.1:

1. Where warranted by climatic conditions, ventilation openings to the outdoors are not required if ventilation openings to the interior are provided.
2. The total area of ventilation openings is permitted to be reduced to $1/1,500$ of the under-floor area where the ground surface is treated with an approved vapor retarder material and the required openings are placed

so as to provide cross ventilation of the space. The installation of operable louvers shall not be prohibited.

3. Ventilation openings are not required where continuously operated mechanical ventilation is provided at a rate of 1.0 cubic foot per minute (cfm) for each 50 square feet (1.02 L/s for each 10 m²) of crawl-space floor area and the ground surface is covered with an approved vapor retarder.
4. Ventilation openings are not required when the ground surface is covered with an approved vapor retarder, the perimeter walls are insulated and the space is conditioned in accordance with the *California Energy Code, Title 24, Part 6*.
5. For buildings in flood hazard areas as established in Section 1612.3, the openings for under-floor ventilation shall be deemed as meeting the flood opening requirements of ASCE 24 provided that the ventilation openings are designed and installed in accordance with ASCE 24.
6. [SPCB] For purposes of structural pest control inspections, ventilation shall be considered inadequate when the lack thereof has contributed to the growth of wood-destroying pests or organisms.

1203.4 Natural ventilation. Natural ventilation of an occupied space shall be through windows, doors, louvers or other openings to the outdoors. The operating mechanism for such openings shall be provided with ready access so that the openings are readily controllable by the building occupants.

[HCD 1] In employee housing, all openable windows in rooms used for living, dining, cooking or sleeping purposes, and toilet and bath buildings, shall be provided and maintained with insect screening.

[HCD 1] Door openings of rooms used for dining, cooking, toilet and bathing facilities in employee housing shall be provided and maintained with insect screening or with solid doors equipped with self-closing devices in lieu thereof, when approved by the enforcement agency.

[HCD 1] The windows, doors, louvers or other approved closeable openings not required by Section 1026 may open into a passive solar energy collector for ventilation required by this section. The area of ventilation openings to the outside of the passive solar energy collector shall be increased to compensate for the openings required by the interior space.

1203.4.1 Ventilation area required. The minimum openable area to the outdoors shall be 4 percent of the floor area being ventilated.

1203.4.1.1 Adjoining spaces. Where rooms and spaces without openings to the outdoors are ventilated through an adjoining room, the opening to the adjoining room shall be unobstructed and shall have an area of not less than 8 percent of the floor area of the interior room or space, but not less than 25 square feet (2.3 m²). The minimum openable area to the outdoors shall be based on the total floor area being ventilated.

Exception: Exterior openings required for ventilation shall be permitted to open into a thermally iso-

lated sunroom addition or patio cover provided that the openable area between the sunroom addition or patio cover and the interior room shall have an area of not less than 8 percent of the floor area of the interior room or space, but not less than 20 square feet (1.86 m²). The minimum openable area to the outdoors shall be based on the total floor area being ventilated.

1203.4.1.2 Openings below grade. Where openings below grade provide required natural ventilation, the outside horizontal clear space measured perpendicular to the opening shall be one and one-half times the depth of the opening. The depth of the opening shall be measured from the average adjoining ground level to the bottom of the opening.

1203.4.2 Contaminants exhausted. Contaminant sources in naturally ventilated spaces shall be removed in accordance with the *California Mechanical Code* and the *California Fire Code*.

1203.4.2.1 Bathrooms. Rooms containing bathtubs, showers, spas and similar bathing fixtures shall be mechanically ventilated in accordance with the *California Mechanical Code*.

1203.4.3 Openings on yards or courts. Where natural ventilation is to be provided by openings onto yards or courts, such yards or courts shall comply with Section 1206.

1203.5 Other ventilation and exhaust systems. Ventilation and exhaust systems for occupancies and operations involving flammable or combustible hazards or other contaminant sources as covered in the *California Mechanical Code* or the *California Fire Code* shall be provided as required by both codes. For Group L occupancies see Section 443.4.7.

SECTION 1204 TEMPERATURE CONTROL

1204.1 Equipment and systems. Interior spaces intended for human occupancy shall be provided with active or passive space-heating systems capable of maintaining a minimum indoor temperature of 68°F (20°C) at a point 3 feet (914 mm) above the floor on the design heating day.

Exceptions:

1. Interior spaces where the primary purpose is not associated with human comfort.
2. [HCD 1] For limited-density owner-built rural dwellings, a heating facility or appliance shall be installed in each dwelling subject to the provisions of Subchapter 1, Chapter 1, Title 25, California Code of Regulations, commencing with Section 74; however, there shall be no specified requirement for heating capacity or temperature maintenance. The use of solid-fuel or solar-heating devices shall be deemed as complying with the requirements of this section. If nonrenewable fuel is used in these dwellings, rooms so heated shall meet current installation standards.
3. [OSHPD 1, 2, 3 & 4] Space heating systems shall comply with the requirements of the *California Mechanical Code*.

**SECTION 1224 [OSHPD 1]
HOSPITALS**

1224.1 Scope. *The provisions of this section shall apply to general acute-care hospitals, acute psychiatric hospitals, and general acute-care hospitals providing only acute medical rehabilitation center services. The provisions of Section 1225 shall apply to distinct part skilled nursing and intermediate-care services on a general acute-care or acute psychiatric hospital license, provided either in a separate unit or a free-standing building.*

1224.2 Application. *New buildings and additions, alterations or repairs to existing buildings subject to licensure shall comply with applicable provisions of the California Electrical Code, California Mechanical Code, California Plumbing Code, California Fire Code (Parts 3, 4, 5 and 9 of Title 24) and this section.*

Exceptions:

1. *Facilities licensed and in operation prior to the effective date of this section shall not be required to institute corrective alterations or construction to comply with any new requirements imposed thereby or subsequently, except where specifically required or where the enforcing agency determines that a definite hazard to health and safety exists. Facilities for which preliminary drawings have been submitted to the enforcing agency prior to the effective date of this change shall not be required to comply with such new requirements, provided working drawings are submitted within one year of the effective date of such new requirements.*
2. *The provisions of this section do not prohibit the use of alternate space utilization, new concepts of design, treatment techniques, equipment and alternate finish materials provided the intent of this section is accommodated and written approval for such alternative is granted by the enforcing agency. Written substantiating evidence in support of the alternate and a written request for consideration shall be submitted to the enforcing agency.*
3. *Nothing in this section shall prohibit the provisions of required services from a centralized service facility serving two or more licensed facilities when approved in writing by the licensing agency. Buildings and required spaces for services provided in a separate centralized services facility shall comply with all applicable provisions of these regulations and applicable local codes and ordinances for the services so provided.*
4. *Acute psychiatric hospitals and general acute-care hospitals providing only acute medical rehabilitation center services may provide for surgical and anesthesia services to be provided by an outside licensed facility when approved by the licensing agency.*
5. *When the Corrections Standards Authority, the Department of Corrections or the Department of Youth Authority determines that a particular requirement for hospitals located in a correctional facility may compromise the safety, security or protection of staff,*

inmates or property, the enforcement agency shall consider an alternate design.

1224.3 Definitions. *For the purpose of this section, the following terms shall have the meaning indicated:*

AIR CONDITIONING. *The process or system by which simultaneously the temperature, humidity, air motion and quality are maintained within required limits.*

AIRBORNE INFECTION ISOLATION ROOM. *A single-occupancy patient room where environmental factors are controlled in an effort to minimize the transmission of those infectious agents usually spread from person to person by droplet nuclei associated with coughing and inhalation.*

AMBULATORY CARE. *A defined health care encounter(s) of less than 24 hours in duration that requires direct professional health care support within a specific facility.*

AMBULATORY SURGICAL FACILITY. *Any surgical facility organized for the purpose of providing procedural, invasive surgical care to patients with the expectation that they will be recovered sufficiently to be discharged in less than a 24-hour period.*

BASIC SERVICES. *Those essential services required for licensure as a hospital, including medical, nursing, surgical, anesthesia, laboratory, radiology, pharmacy, dietary services and support services. See "SUPPLEMENTAL SERVICES."*

BIOTERRORISM. *The use, or threat of use, of biological agents to intimidate a political entity or population group.*

CENTRAL AIR-HANDLING SYSTEMS. *Any units requiring ductwork on the supply or inlet side and serving more than one room.*

COURT. *An open exterior space bounded on three or more sides by the walls of a structure.*

ENVIRONMENT OF CARE. *Those features in a built health care entity that are created, structured, and maintained to support quality health care.*

FLOOR AREA, CLEAR. *The actual occupied area exclusive of fixed or wall-mounted cabinets, built-in shelves, toilet rooms, closets, lockers, wardrobes, alcoves, anterooms or vestibules.*

GENERAL ACUTE-CARE HOSPITAL. *A hospital, licensed by the Department of Health Services, having a duly constituted governing body with overall administrative and professional responsibility and an organized medical staff which provides 24-hour inpatient care, including the basic services.*

GOOSENECK SPOUT. *A deck or fixture-mounted spout shaped so the discharge point is at least 5 inches (127 mm) above the fixture rim.*

HANDWASHING FIXTURE. *A special application sink having a water supply spout mounted so the discharge point is at least 5 inches (127 mm) above the fixture rim and equipped with hot and cold supply controls not requiring direct contact of the hands for operation. The fixture cannot be equipped with an aerator and wrist or elbow blade handles, but may be equipped with a nonaerating laminar flow device. Sensor operated fixtures may be used, provided they are either battery operated or connected to the essential electrical system.*

HOSPITAL. A general acute-care hospital, including those providing only acute medical rehabilitation center services and acute psychiatric hospitals.

HOUSEKEEPING. Services anywhere within a health care facility that include general cleaning and tidying and the provision and positioning of identified materials, e.g., soaps, towels, etc. (While routine disinfection protocols can be included in such a definition, the definition is not intended to include complex, nonroutine disinfection procedures nor the nonroutine disposition of hazardous materials such as potentially toxic drugs or other chemicals and radioactive wastes.)

LDR. Labor, Delivery, Recovery (an unlicensed patient bed)

LDRP. Labor, Delivery, Recovery, Postpartum (a licensed patient bed)

LICENSING AGENCY. The Department of Public Health, Licensing and Certification.

NURSING UNIT. A designated patient care area of the hospital which is planned, organized, operated and maintained to function as a unit. It includes patient rooms with adequate support facilities, services and personnel providing nursing care and necessary management of patients.

OPERATING ROOM. A room specifically designed for the performance of surgical procedures. (In common understanding, this means most types of surgical procedures, especially those involving the administration of anesthesia, multiple personnel, recovery room access, and a fully controlled environment.)

OUTPATIENT SERVICE. An organizational unit of the hospital, which provides nonemergency healthcare services to patients.

PATIENT ROOM. Licensed patient bed rooms.

PERIOPERATIVE. Patient care and other related supportive activities before, during or after the operative event.

PROTECTIVE ENVIRONMENT. A bedded unit or patient room where severely immunosuppressed patients are cared for.

SCRUB SINK. A sink used to wash and scrub the hands and arms during the aseptic preparation for surgery, and equipped with a supply spout and controls as required for a handwashing fixture.

SERVICE SINK. A sink located in a housekeeping room and designed for the purpose of cleaning mops and the disposal of waste water.

SUB-ACUTE CARE. A segment within a continuum of levels of care determined by patient acuity, clinical stability, and resource needs.

SUPPLEMENTAL SERVICE. An inpatient or outpatient service which is not required to be provided by law or regulation for licensure. A supplemental service, when provided, must accommodate the provisions of this section.

Note: See "BASIC SERVICES."

SURGICAL SERVICE SPACE. A space that includes the operating room(s) and service areas.

1224.4 GENERAL CONSTRUCTION.

1224.4.1 Services/systems and utilities. Services/systems and utilities that are necessary to the operation of an acute care hospital, skilled nursing facility, intermediate care facility, or correctional treatment center shall meet the structural requirements of this section. Examples of services/systems and utilities include normal power; emergency power; nurse call; fire alarm; communication and data systems; space-heating systems; process load systems; cooling systems; domestic hot and cold water systems; fire-suppression systems; building drain and sewer systems; and medical gas systems that support basic and supplemental services.

Services from an acute care hospital, skilled nursing facility or a correctional treatment center may serve a building that does not comply with the structural requirements of the 1973 edition or later edition of the California Building Standards Code with prior approval of the Office.

Exception: Remodel projects that use available existing services/systems and utilities are exempted from the requirements of this section. The authority having jurisdiction may exempt minor addition, minor alteration, and minor remodel projects and projects to upgrade existing services/systems and utilities from the requirements of this section.

1224.4.1.1 Services/systems and utilities for hospital buildings.

1224.4.1.1.1 Additions, alterations, and remodels of conforming (SPC-3, -4, or -5) hospital buildings. Services/systems and utilities for new buildings and additions, and alterations or remodels to existing conforming buildings shall originate in hospital buildings that have OSHPD-approved performance categories of SPC-3 or higher and NPC-4 or higher. The services/systems and utilities shall not pass through or under buildings that do not have OSHPD-approved performance categories of SPC-2 or higher and NPC-4 or higher.

Exceptions:

1. Remodel and alteration projects that use available existing services/systems and utilities are exempted from these requirements.
2. Services/systems and utilities may pass through or under buildings that have OSHPD-approved nonstructural performance categories of NPC-2 or NPC-3, provided that the services/systems and utilities feeding the new building addition, alteration, or remodel conform with ASCE 7 Chapter 13 as modified in Section 1614A and are deemed by OSHPD to be free of adverse seismic interactions caused by potential failure of overhead or adjacent components.

1224.4.1.1.2 Additions, alterations, and remodels of SPC-2 hospital buildings. Services/systems and utilities for additions, alterations, or remodels of SPC-2 hospital buildings may originate in and pass through or under SPC-2 or better buildings that have an OSHPD-approved nonstructural performance category of NPC-3 or higher.

Exception: Services/systems and utilities may pass through or under buildings that have OSHPD-approved nonstructural performance categories of NPC-2, provided that the services/systems and utilities feeding the addition, alteration, or remodel conform with Chapter 34A and are deemed by OSHPD to be free of adverse seismic interactions caused by potential failure of overhead or adjacent components.

1224.4.1.1.3 Alterations and remodels of SPC-1 hospital buildings. Services/systems and utilities for alterations or remodels of SPC-1 hospital buildings may originate in and pass through or under SPC-1 or better buildings that have an OSHPD-approved nonstructural performance category of NPC-2 or higher.

1224.4.1.1.4 Buildings without SPC/NPC ratings. When services/systems and utilities for new buildings, additions, alterations, or remodels pass through or under hospital buildings which would not otherwise require evaluation for an SPC rating, such buildings shall be evaluated in accordance with the requirements of Section 1.3, Chapter 6, Part 1, California Building Standards Administrative Code, to determine the appropriate ratings, or shall be shown to meet the structural requirements of these regulations for new hospital buildings. The services/systems and utilities feeding the new building addition, alteration, or remodel shall conform with ASCE 7 Chapter 13 as modified in Section 1614A and shall be deemed by OSHPD to be free of adverse seismic interactions caused by potential failure of overhead or adjacent components.

1224.4.1.1.5 Buildings removed from acute-care hospital service. Services/systems and utilities for conforming acute care hospital buildings may pass through or under a building that has been removed from acute care hospital service until January 1, 2030 if the building removed from service remains under the jurisdiction of OSHPD and meets the performance requirements of Section 1224.4.1.1.1. Services/systems and utilities for nonconforming acute care hospital buildings may pass through or under a building that has been removed from acute care hospital service only if the building removed from service remains under the jurisdiction of OSHPD and meets the performance requirements of Section 1224.4.1.1.2.

Exception: Service/system and utilities for acute care hospital buildings may pass through or under

the buildings that have been removed from acute care service and which do not meet the performance requirements of Section 1224.4.1.1.1 or Section 1224.4.1.1.2, provided all of the following are met:

1. The hospital has obtained an approved extension to the 2008 deadlines in accordance with Section 1.5.2, Article 1, Chapter 6 California Building Standards Administrative Code.
2. The extensions request specifically includes a request to allow services/systems and utilities to pass through or under the building removed from acute care service. The services/systems and utilities may pass through or under the building for the duration of the extension.
3. The building removed from acute care service remains under the jurisdiction of OSHPD.

After January 1, 2030, services/systems and utilities for acute care hospital buildings shall not originate in or pass through or under a nonhospital building unless it has OSHPD-approved performance categories of SPC-3 or better and NPC-4 or better; and the nonhospital building remains under the jurisdiction of OSHPD.

1224.4.1.2 Services/systems and utilities for skilled nursing facilities, intermediate care facilities, and correctional treatment centers.

1224.4.1.2.1 New buildings and additions. Services/systems and utilities for new buildings and additions shall not originate in or pass through or under structures that do not comply with the structural requirements of the 1973 edition or later edition of the California Building Standards Code. The structures must be under the jurisdiction of OSHPD.

Exception: As an alternate to this section, skilled nursing and intermediate care facilities, and correctional treatment centers may meet the requirements in Section 1224.4.1.1 for hospital buildings.

1224.4.1.2.2 Alterations and remodels. Services/systems and utilities for alterations or remodels of existing buildings may pass through structures that do not comply with the structural requirements of the 1973 edition or later edition of the California Building Standards Code, provided that the structure is under the jurisdiction of OSHPD, and the new services/systems and utilities passing through the buildings are anchored and braced for seismic forces in accordance with these regulations for new buildings and are free of adverse seismic interactions caused by potential failure of overhead or adjacent components.

1224.4.2 Service spaces. Spaces for dietary, laundry, morgue, ambulance entrance, receiving areas, power plants, mechanical equipment, incinerator, garbage can

cleaning, automobile parking and storage areas for garbage, trash and medical gases shall be located and constructed to minimize noise, steam, odors, hazards and unsightliness in patient-care areas and bedrooms.

1224.4.3 Treatment spaces. Radiology, laboratory, pharmacy, physical therapy and service spaces serving only outpatients and similar outpatient service departments shall not be located in nursing units, surgical units, perinatal units, nursery areas, central sterilization rooms, food-service areas, power plants, mechanical equipment rooms, maintenance shops, general storage, laundry, employees' dressing or housekeeping facilities.

Exception: Physical and occupational therapy spaces of a rehabilitation service may serve both outpatients and inpatients.

1224.4.4 Examination or treatment room. Unless specified elsewhere, if a treatment room or an exam room is provided, it shall have a minimum clear floor area of 80 square feet (7.4 m²), the least dimension of which shall be 8 feet (2438 mm). The room shall contain a handwashing fixture.

1224.4.5 Outpatient access. If x-ray examinations are to be performed on outpatients, outpatient access to the radiological spaces shall not traverse a nursing unit.

Exception: Satellite radiology, laboratory, pharmacy, physical and occupational therapy space serving inpatients may be located in nursing units and inpatient treatment areas.

1224.4.6 Oxygen, vacuum and medical air.

1224.4.6.1 Outlets/inlets. Shall comply with Table 1224.2.

1224.4.6.2 Gas and vacuum systems. The design, installation and testing of medical gas and vacuum systems shall conform to NFPA 99.

1224.4.6.3 Hyperbaric facilities. The design and construction of hyperbaric facilities shall conform to NFPA 99.

1224.4.6.4 Laboratories. The design and construction of hospital laboratories shall conform to NFPA 99.

1224.4.6.5 Bulk oxygen systems. Bulk oxygen systems shall conform to NFPA 50.

1224.4.7 Corridors.

1224.4.7.1 Width. The minimum width of corridors and hallways shall be 8 feet (2438 mm).

Exception: Patient-care corridors and hallways in hospitals for psychiatric care of patients who are not bedridden shall have a minimum clear and unobstructed width of 6 feet (1829 mm). For the purposes of this section, bedridden patients shall be defined as patients confined to beds who would be transported or evacuated in beds or litters.

1224.4.7.2 Light traffic. Service corridors and hallways with anticipated light traffic volume for nonpatient use

may be reduced to a width of 5 feet (1524 mm) if approved by the enforcing agency.

Exception: Corridors and hallways in administrative and business areas may be reduced to a width of 44 inches (1118 mm).

1224.4.7.3 Outpatient services. Outpatient clinics or outpatient departments which contain facilities for outpatient use only, such as laboratory, x-ray, physical therapy or occupational therapy, shall have a minimum corridor or hallway width of 5 feet (1524 mm). Outpatient clinics and outpatient departments consisting only of waiting rooms, business offices, doctor's offices, and examining rooms, where there is no traffic through such area to other services or to exits from the building, shall have a minimum corridor or hallway width of 44 inches (1118 mm).

1224.4.7.4 Handrails. Corridors for patient traffic in areas providing skilled nursing, intermediate care or rehabilitation services shall be furnished with a handrail on both sides at a height not less than 30 inches (762 mm) or greater than 36 inches (914 mm).

1224.4.7.5 Connections. Corridor systems shall connect all patient rooms and basic services.

Exception: Covered pedestrian walkways connecting separate buildings are permitted for ambulatory, psychiatric or chemical dependency patients.

1224.4.8 Doors and door openings.

1224.4.8.1 Toilet room doors. Doors to toilet rooms shall have an opening of not less than 32 inches (813 mm) clear in width and shall be equipped with hardware which will permit the door to swing outward or in a manner to negate the need to push against a patient who may have collapsed within the toilet room.

1224.4.8.2 Pocket doors. Pocket sliding doors are not permitted.

Exception: Administration and business areas.

1224.4.9 Windows and screens.

1224.4.9.1 Windows. Rooms approved for the housing of patients shall be provided with natural light by means of exterior glazed openings excluding clerestory window, obscure glass and skylights, with an area not less than one tenth of the total floor area.

Exception: Newborn intensive-care units shall comply with Section 1224.29.2.12 Daylight.

1224.4.9.2 Operation and sills. Patient room windows shall have sills not more than 36 inches (914 mm) above the floor. If operable windows are provided that require the use of tools or keys for operation, the tools or keys shall be located at the nurses' station.

Exception: Window sills in intensive-care units may be 60 inches (1524 mm) above the floor.

1224.4.9.2.1 Airborne infection isolation or protective environment rooms. If operable windows are

1224.4.15 Housekeeping room. This room shall be a minimum floor area of 15 square feet (1.4 m²). It shall contain a service sink or floor receptor and provisions for storage of supplies and housekeeping equipment.

1224.4.16 Laundry and trash chutes. Gravity-type laundry and trash chutes shall have a minimum diameter of 2 feet (610 mm) and shall be designed to prevent distribution of airborne contaminating elements to all floors served.

1224.4.17 Telephone. Each floor accommodating patients shall have a telephone installed for patient use. Such telephones shall be readily accessible to patients who are limited to wheel chairs and stretchers. This may not be required in separate buildings having six or fewer beds which are restricted to occupancy by ambulatory patients.

1224.5 Reserved

1224.6 Reserved

1224.7 Reserved

1224.8 Reserved

1224.9 Reserved

1224.10 Reserved

1224.11 Reserved

1224.12 Reserved

1224.13 Reserved

BASIC SERVICES

1224.14 NURSING SERVICE SPACE.

1224.14.1 Patient rooms.

1224.14.1.1 Capacity. No patient room shall be designed to accommodate more than eight beds.

1224.14.1.2 Space requirements. In new construction, patient rooms shall have a minimum of 100 square feet (9.29 m²) of clear floor area per bed in multiple-bed rooms and 120 square feet (11.15 m²) of clear floor area for single-bed rooms. The dimensions and arrangement of rooms shall be such that there is a minimum of 3 feet (914 mm) between the sides and foot of the bed and any wall or any other fixed obstruction. In multiple-bed rooms, a clearance of 4 feet (1219 mm) shall be available at the foot of each bed to permit the passage of equipment and beds.

Exceptions:

1. Where renovation of existing patient rooms is undertaken in facilities built under the 2001 or prior California Building Code, patient rooms shall have no less than 80 square feet (7.43 m²) of clear floor area per bed in multiple-bed rooms and 110 square feet (10.22 m²) of clear floor area in single-bed rooms.
2. For shelled spaces built under the 2001 or prior California Building Code, patient rooms shall have no less than 80 square feet (7.43 m²) of clear floor area per bed in multiple-bed rooms

and 110 square feet (10.22 m²) of clear floor area in single-bed rooms.

1224.14.1.3 Windows. Each patient room shall have a window in accordance with Section 1224.4.9.

1224.14.1.4 Arrangement. Patient rooms shall not be designed to permit the placement of beds more than three deep from the exterior window, but shall be of such shape and dimensions to allow for the performance of routine functions, including the easy transfer of patients to and from bed to wheelchair or wheeled gurney.

1224.14.1.5 Outside exposure. All patient bedrooms shall have an outside exposure and shall not be below ground level.

1224.14.1.6 Handwashing fixtures. A handwashing fixture shall be provided in the patient room. In multiple-bed rooms the handwashing fixture shall be located outside of the patient's cubicle curtain so that it is accessible to staff. Where renovation of patient rooms is undertaken a handwashing fixture shall be located in the toilet room or patient room.

1224.14.1.7 Toilet room. Each patient shall have access to a toilet room without having to enter the general corridor area. One toilet room shall serve no more than four beds and no more than two patient rooms. The toilet room shall contain a water closet and a lavatory and the door shall swing outward or be double acting.

1224.14.1.8 Patient storage. Each patient shall have within his or her room a separate wardrobe, locker, or closet suitable for hanging full-length garments and for storing personal effects.

1224.14.1.9 Privacy. In multiple-bed rooms, visual privacy from casual observation by other patients and visitors shall be provided for each patient. The design for privacy shall not restrict patient access to the entrance, lavatory, or toilet room.

1224.14.2 Service areas. Unless otherwise indicated, provision for the services listed below shall be in or readily available to each nursing unit. The size and location of each service area will depend upon the numbers and types of beds served. Identifiable spaces are required for each of the indicated functions. Each service area may be arranged and located to serve more than one nursing unit but, unless noted otherwise, at least one such service area shall be provided on each nursing floor. Where the words "room" or "offices" are used, a separate, enclosed space for the one named function is intended; otherwise, the described area may be specific space in another room or common area.

1224.14.2.1 Administrative center(s) or nurse station(s). This area shall have space for counters and storage and shall have convenient access to handwashing fixtures. It may be combined with or include centers for reception, charting and communication.

1224.14.2.2 Nurse or supervisor office.

1224.14.2.3 Toilet room(s) conveniently located for staff use.

1224.14.2.4 Multipurpose room(s) for staff, patients, patients' families for patient conferences, reports, education, training sessions, and consultation. These rooms must be accessible to each nursing unit. They may be on other floors if convenient for regular use. One such room may serve several nursing units and/or departments.

1224.14.2.5 Examination or treatment room(s). Examination or treatment rooms are optional. If provided, provision shall be made to preserve patient privacy from observation from outside the exam room through an open door.

1224.14.2.6 Clean utility room. If the room is used for preparing patient care items, it shall contain a work counter, a handwashing fixture, and storage facilities for clean and sterile supplies. If the room is used only for storage and holding as part of a system for distribution of clean and sterile materials, the work counter and handwashing fixture may be omitted. Soiled and clean utility or holding rooms shall be separated and have no direct connection.

1224.14.2.7 Soiled workroom or soiled holding room. This room shall be separate from the clean utility room. The soiled workroom utilities room shall contain a clinical sink (or equivalent flushing-rim fixture). The room shall contain a handwashing fixture. The above fixtures shall both have a hot and cold mixing faucet. The room shall have a work counter and space for separate covered containers for soiled linen and waste. Rooms used only for temporary holding of soiled material may omit the clinical sink and work counter. If the flushing-rim clinical sink is eliminated, facilities for cleaning bedpans shall be provided elsewhere.

1224.14.2.8 Medication station. Provision shall be made for distribution of medications. This shall be done from a medicine preparation room or from a self-contained medicine dispensing unit.

1224.14.2.8.1 Medicine preparation room. If provided, this room shall be directly accessible from the nursing station. It shall contain a work counter, handwashing fixture, refrigerator, and locked storage for controlled drugs. When a medicine preparation room is to be used to store one or more self-contained medicine dispensing units, the room shall be designed with adequate space to prepare medicines with the self-contained medicine dispensing unit(s) present.

1224.14.2.8.2 Self-contained medicine dispensing unit. If provided, a self-contained medicine dispensing unit shall be located at the nurses' station, in the clean utility room, or in an alcove.

1224.14.2.9 Clean linen storage. Each nursing unit shall contain a designated area for clean linen storage. This may be within the clean utility room or a separate closet.

1224.14.2.10 Nourishment area. There shall be a nourishment area with sink, work counter, refrigerator, storage cabinets, and equipment for hot and cold nourishment between scheduled meals. The nourishment

area shall include space for trays and dishes used for nonscheduled meal service. Provisions and space shall be included for separate temporary storage of unused and soiled dietary trays not picked up at mealtime. Handwashing fixtures shall be in or adjacent to the nourishment area.

1224.14.2.11 Ice machine. Each nursing unit shall have equipment to provide ice for treatments and nourishment. Ice making equipment may be in the clean utility room/holding room or at the nourishment station. Ice intended for human consumption shall be from self-dispensing icemakers.

1224.14.2.12 Equipment storage room. Appropriate room(s) shall be provided for storage of equipment necessary for patient care. Each unit shall provide not less than 10 square feet (0.93 m²) per patient bed.

1224.14.2.13 Gurneys and wheelchairs. Provide a storage room or alcove for gurneys and wheelchairs which shall be a minimum of 15 square feet (1.39 m²).

1224.14.2.14 Showers and bathtubs. When individual bathing facilities are not provided in patient rooms, there shall be at least one shower and/or bathtub for each 12 beds without such facilities. Each bathtub or shower shall be in an individual room or enclosure that provides privacy for bathing, drying, and dressing. Special bathing facilities, including space for attendant, shall be provided for patients on gurneys, carts, and wheelchairs at the ratio of one per 100 beds or a fraction thereof. This may be on a separate floor if convenient for use.

1224.14.2.15 Patient toilet room(s), in addition to those serving bed areas, shall be conveniently located to multipurpose room(s) and within or directly accessible to each central bathing facility.

1224.14.2.16 Emergency equipment storage. Space shall be provided for emergency equipment that is under direct control of the nursing staff, such as a cardiopulmonary resuscitation (CPR) cart. This space shall be directly accessible from the nursing station, but out of normal traffic.

1224.14.2.17 Housekeeping room.

1224.14.3 Airborne infection isolation rooms.

1224.14.3.1 General. Single rooms shall be provided for the isolation of patients with airborne communicable disease at a ratio of one room for each 35 licensed beds, or major fraction thereof. At least one airborne infection isolation room shall be provided. Airborne infection isolation rooms shall be labeled with the words "Airborne Infection Room" on or adjacent to the anteroom side of the door between the isolation room and the anteroom.

Exceptions:

1. Acute psychiatric hospitals shall provide airborne infection isolation rooms at the ratio of one room for each 50 beds, or major fraction thereof.

2. Airborne infection isolation rooms are not required for chemical dependency recovery services.

1224.14.3.2 Anteroom doors. Airborne infection isolation room(s) shall have self-closing and latching devices on all anteroom doors.

1224.14.3.3 Anteroom. A separate anteroom shall be provided between the airborne infection isolation room and the corridor, which shall constitute the primary entrance to the airborne infection isolation room. This anteroom shall have a handwashing fixture, work counter at least 3 feet (914 mm) long, cabinets and space to gown and to store clean and soiled materials. There shall be a view window from the anteroom to the isolation room and means to allow for airflow from the anteroom into the airborne infection isolation room. Doors shall be aligned to allow large equipment to be wheeled into the airborne infection isolation room unless a secondary door complying with Section 1224.14.3.2 is provided. One anteroom may serve no more than two airborne infection isolation rooms.

1224.14.3.4 Secondary entry. When a secondary entry is provided, the secondary doors shall be provided with locking devices which are readily operable from the room side and which are readily operable by the facility staff on the other side. When key locks are used on isolation rooms, keys shall be located at the nurses' station in a prominent readily accessible location.

1224.14.3.5 Sealed-tight room. Airborne infection isolation room perimeter walls, ceilings, floors, doors, and penetrations shall be sealed tightly to minimize air infiltration from the outside or from other spaces.

1224.14.3.6 Adjoining toilet room. Each isolation room shall have its own adjoining toilet room with an emergency nurse call system, a lavatory, a shower providing a seat or a space for a shower chair and a toilet equipped with a bedpan flushing attachment with a vacuum breaker.

1224.14.4 Protective environment room(s).

1224.14.4.1 General. Protective environment rooms for the protection of certain immunosuppressed patients may be provided by the facility. Protective environment rooms shall be labeled. "Protective Environment Room" on or adjacent to the anteroom side of the door between the isolation room and the anteroom. Protective environment rooms shall contain only one bed.

1224.14.4.2 Anteroom doors. Protective environment room (s) shall have self-closing and latching devices on all anteroom doors.

1224.14.4.3 Anteroom. A separate anteroom shall be provided between the protective environment room and the corridor, hallway or adjoining space which shall constitute the only entrance to the protective environment room. This anteroom shall have a handwashing fixture, work counter at least 3 feet (914 mm) long, cabinets

and space to gown and to store clean and soiled materials. There shall be a view window from the anteroom to the protective environment room. There shall be means to allow for airflow from the protective environment room into the anteroom. Anteroom doors shall be aligned so that large equipment can be wheeled into the protective environment room. One anteroom may serve no more than one protective environment room.

Exception: Alternate designs for protective environment rooms, without individual anterooms, may be approved by the enforcement agency when it can be demonstrated that the alternate design meets the requirements of the California Mechanical Code and does not compromise or alter any health or fire protection component, assembly or system.

1224.14.4.4 Adjoining toilet room. Room shall meet the requirements of Section 1224.14.4.5.

1224.14.4.5 Sealed-tight room. Protective environment room perimeter walls, ceiling, floors, doors, and penetrations shall be sealed tightly to minimize air infiltration from the outside or from other spaces.

1224.14.5 Seclusion room(s). If provided, the hospital shall provide one or more single bedrooms for patients needing close supervision for medical and/or psychiatric care. This may be part of the psychiatric unit described in Section 1224.31. If the single bedroom(s) is part of the acute-care nursing unit, the provisions of Section 1224.14.1 shall apply, with the following exceptions: each room shall be for single occupancy; each shall be located to permit staff observation of the entrance, preferably adjacent to the nurses' station; and each shall be designed to minimize the potential for escape, hiding, injury, or suicide. If vision panels are used for observation of patients, the arrangement shall insure patient privacy and prevent casual observation by visitors and other patients.

1224.15 SURGICAL SERVICE SPACE. A minimum of one operating room and one recovery bed is required. The surgical service space shall be located and arranged to prevent nonrelated traffic through the service space.

Exception: Surgical service space is not required in a rural general acute care hospital.

1224.15.1 Surgery.

1224.15.1.1 General operating room(s). In new construction, each room shall have a minimum clear floor area of 400 square feet (37.16 m²) with a minimum of 20 feet (6096 mm) clear dimension between fixed cabinets and built-in shelves; and a system for emergency communication with the surgical service space control station. X-ray or imaging viewing capabilities shall be provided.

Exception:

1. Where renovation of existing operating rooms is undertaken in facilities built under the 2001 or prior California Building Code, each operating room shall have a minimum clear floor

area of 324 square feet (30.10 m²) with a minimum of 18 feet (5486 mm) clear dimension between fixed cabinets and built-in shelves.

2. For shelled floor spaces built under the 2001 or prior California Building Code, each existing operating room shall have a minimum clear floor area of 324 square feet (30.10 m²) with a minimum of 18 feet (5486 mm) clear dimension between fixed cabinets and built-in shelves.

1224.15.1.2 Surgical cystoscopic and other endo-urologic procedures. In new construction each room shall have a minimum clear floor area of 250 square feet (23.23 m²) with a minimum of 15 feet (4572 mm) clear dimension between fixed cabinets and built-in shelves. X-ray viewing capability shall be provided.

Exception:

1. Where renovation of operating rooms is undertaken in facilities built under the 2001 or prior California Building Code rooms for surgical cystoscopy shall have a minimum clear floor area of 180 square feet (16.72 m²). Cast rooms for open reductions, if provided, shall have a minimum clear floor area of 180 square feet (16.72 m²), no dimension of which shall be less than 11 feet (3353 mm).
2. For shelled spaces built under the 2001 or prior California Building Code, each surgical cystoscopy shall have a minimum clear floor area of 180 square feet (16.72 m²). Cast rooms for open reductions, if provided, shall have a minimum floor area of 180 square feet (16.72 m²), no dimension of which shall be less than 11 feet (3353 mm).

1224.15.2 Preoperative patient holding area(s). In facilities with two or more operating rooms, area(s) shall be provided to accommodate gurney patients or sitting space for ambulatory patients not requiring gurneys. These area(s) shall be under the direct visual control of the nursing staff and may be part of the recovery service space. Each gurney station shall be a minimum clear floor area of 80 square feet (7.43 m²) and shall have a minimum clearance of 3 feet (914 mm) on the sides of the gurneys and the foot of the gurney. Provisions for patient privacy such as cubicle curtains shall be made.

1224.15.3 Service areas. Services, except for the enclosed soiled workroom referenced in Section 1224.15.3.7 and the housekeeping room referenced in Section 1224.15.3.12. Housekeeping room may be shared with the obstetrical facilities. Service areas, when shared with delivery rooms, shall be designed to avoid the passing of patients or staff between the operating room and the delivery room areas.

1224.15.3.1 Control station. Control stations shall be located to permit visual observation of all traffic into the surgical service space.

1224.15.3.2 Supervisor's office or station.

1224.15.3.3 Sub sterile areas. If provided, a sub sterile area(s) shall be equipped with a flash sterilizer, warming

cabinet, and handwashing fixture. If a sterilizing facility(ies) with high-speed sterilizer(s) or other sterilizing equipment for immediate or emergency use are provided, they shall be grouped to service several operating rooms for convenient, efficient use; and a work space and handwashing fixture shall be included. Other facilities for processing and sterilizing reusable instruments, etc., may be located in another hospital department such as central services.

1224.15.3.4 Medication station. Shall be provided in accordance with Section 1224.14.2.8.

1224.15.3.5 Scrub facilities. Scrub sinks shall be located outside of sterile areas. A minimum of two scrub sinks shall be provided in a surgical unit containing one operating room. Four scrub sinks shall be provided in surgical units containing two operating rooms. One additional scrub sink shall be provided for each additional operating room. Scrub sinks shall have water supply controls not requiring direct contact of the hands for operation.

1224.15.3.6 Clock. A direct-wired or battery-operated clock or other equivalent timing device shall be visible from the scrub-up sinks.

1224.15.3.7 Soiled workroom. An enclosed soiled workroom (or soiled holding room that is part of a system for the collection and disposal of soiled material) for the exclusive use of the surgical service space shall be provided. The soiled workroom shall contain a flushing-rim clinical sink or equivalent flushing-rim fixture, a handwashing fixture, a work counter, and space for waste receptacles and soiled linen receptacles. Rooms used only for temporary holding of soiled material may omit the flushing-rim clinical sink and work counters. However, if the flushing-rim clinical sink is omitted, other provisions for disposal of liquid waste shall be provided. The room shall not have direct connection with operating rooms. Soiled and clean utility room or holding rooms shall be separated. The soiled workroom shall provide 24 square feet (2.23 m²) per operating room up to eight operating rooms and shall have a minimum area of 48 square feet (4.46 m²), with no dimension less than 6 feet (1829 mm).

1224.15.3.8 Clean utility room. This room shall not be used for food preparation.

1. A clean utility room is required when clean materials are assembled within the surgical service space prior to use or following the decontamination cycle. It shall contain a work counter, a handwashing fixture, storage facilities for clean supplies, and a space to package reusable items. The storage for sterile supplies must be separated from this space. If the room is used only for storage and holding as part of a system for distribution of clean supply materials, the work counter and handwashing fixture may be omitted. Soiled and clean utility rooms or holding rooms shall be separated.

2. An operating room service space design with a sterile core must provide for no cross traffic of staff and supplies from the decontaminated/soiled areas to the sterile/clean areas. The use of facilities outside the operating room for soiled/decontaminated processing and clean assembly and sterile processing will be designed to move the flow of goods and personnel from dirty to clean/sterile without compromising universal precautions or aseptic techniques in both departments.

1224.15.3.9 Anesthesia workroom. Provide an anesthesia workroom for cleaning, testing, and storing anesthesia equipment. This room shall contain work counter(s) and sink(s) and racks for cylinders.

1224.15.3.10 Equipment storage room(s) for equipment and supplies used in surgical service space. Each surgical service space shall provide sufficient storage area to keep its required corridor width free of equipment and supplies, but not less than 150 square feet (13.94 m²) or 50 square feet (4.65 m²) per operating room, whichever is greater.

1224.15.3.11 Staff clothing change areas. Appropriate areas shall be provided for male and female personnel (orderlies, technicians, nurses, and doctors) working within the surgical service space. The areas shall contain lockers, showers, toilets, lavatories equipped for handwashing, and space for donning surgical attire. These areas shall be arranged to encourage a one-way traffic pattern so that personnel entering from outside the surgical service space can change and move directly into the surgical service space.

1224.15.3.12 Housekeeping room. Shall be provided for the exclusive use of the surgical service space. It shall be directly accessible from the service space.

1224.16 ANESTHESIA SERVICE SPACE.

1224.16.1 Post-anesthetic care units (PACUs). Each PACU shall contain a medication station in accordance with Section 1224.14.2.8; handwashing fixtures; nurse control with charting facilities; clinical sink, refrigerator; provisions for bedpan cleaning; and storage space for gurneys, supplies, and equipment. Additionally, the design shall provide a minimum of 80 square feet (7.43 m²) for each patient station with clearance of at least 5 feet (1524 mm) between patient gurneys and 4 feet (1218 mm) between patient gurneys and adjacent walls. Provisions for patient privacy such as cubicle curtains shall be made. In new construction, at least one door to the recovery room shall access directly from the surgical service space without crossing public corridors. Handwashing fixtures shall be provided with at least one for every four gurneys uniformly distributed to provide equal access from each patient gurney.

Exception: In a rural general acute care hospital, when the surgical service space is not provided, the anesthesia service space is not required.

1224.17 CLINICAL LABORATORY SERVICE SPACE.

1224.17.1 General requirements. All hospitals shall provide space and equipment to perform urinalysis, complete

blood counts, hemoglobin blood typing and cross matching. If laboratory facilities for bacteriological, serological, pathological and additional hematological procedures are not available in the community, then space, equipment and supplies for such procedures shall be provided. The following physical facilities shall be provided:

1. Laboratory work space.
2. Refrigerated blood storage facilities for transfusions shall be provided. Blood storage refrigerator shall be equipped with temperature-monitoring and alarm signals that are monitored continuously.
3. Handwashing fixture.

1224.18 RADIOLOGICAL/IMAGING SERVICE SPACE.

1224.18.1 Minimum requirements. Hospital shall provide a minimum of:

1. One fluoroscopy room, which can also provide x-ray examination services.
2. Space for processing images.
3. A toilet room adjoining each fluoroscopy room, in addition to other toilet room facilities located adjacent to or in the immediate vicinity.
4. An office or other suitable area for viewing and reporting radiographic examination.
5. Storage spaces for all image equipment, supplies and copies of reports.
6. Handwashing fixtures located within the unit.
7. Dressing room facilities.

1224.18.1.1 Radiation protection. A certified physicist or other qualified expert shall specify the type, location, and amount of radiation protection to be installed in accordance with the final approved department layout and equipment selections. Where protected alcoves with view windows are required, a minimum of 1'-6" (0.45 meter) between the view window and the outside partition edge shall be provided. Radiation protection requirements shall be incorporated into the construction documents and comply with Chapter 31C and the requirements of California Radiation Control Regulations, California Code of Regulations, Title 17, Division 1, Chapter 5, and Subchapter 4.

1224.18.2 Angiography. If provided, angiography space shall accommodate the following:

1. A control room with a view window to permit full view of the patient.
2. A scrub sink located outside the staff entry to the procedure room.
3. Patient holding area shall accommodate at least one patient gurney with a minimum of 3-foot (1524 mm) clearance on the long side.
4. Storage for portable equipment and catheters shall be provided.

1224.18.3 Computerized tomography (CT) scanning. If provided, CT space shall accommodate the following:

1224.18.3.1 Spaces required. If provided, CT scan spaces shall accommodate the equipment with a minimum of 3 feet (1524 mm) on all sides of the equipment, together with the following:

1. A control room shall be provided that is designed to accommodate the computer and other controls for the equipment. A view window shall be provided to permit view of the patient.
2. A patient toilet room convenient to the procedure room.

1224.18.4 Magnetic resonance imaging (MRI). If provided, the MRI room shall accommodate the equipment with a minimum of 3 feet (1524 mm) on all sides of the equipment, together with the following:

1. A control room shall be provided with full view of the MRI.
2. A computer room shall be provided.

1224.18.5 Ultrasound. If ultrasound is provided, a patient toilet room, accessible from the procedure room, shall be provided.

1224.18.6 Support spaces. The following spaces are common to the imaging service area and are minimum requirements unless stated otherwise:

1224.18.6.1 Patient's toilet room(s). In service spaces with procedure rooms that do not have dedicated patient toilets, provide a minimum of one patient toilet room within the service space.

1224.18.6.2 Patient dressing rooms. Dressing rooms shall be provided convenient to the imaging rooms.

1224.18.6.3 Staff facilities. In service space of three or more procedure rooms, staff toilet room(s) internal to the service space shall be provided.

1224.18.6.4 Film storage (active). If film systems are used provide the following:

1. A room with cabinet or shelves for filing patient film for immediate retrieval shall be provided.
2. Storage facilities for unexposed film which shall include protection of film against exposure or damage.

1224.18.6.5 Locked storage. Provision shall be made for locked storage of medications and drugs.

1224.19 PHARMACEUTICAL SERVICE SPACE.

1224.19.1 Licensed pharmacy. All hospitals having a licensed capacity of 100 or more beds shall have a pharmacy on the premises licensed by the California Board of Pharmacy.

Note: See General Acute Care Hospitals §70263(a), Article 3, Chapter 1, Division 5, Title 22, California Code of Regulations, for requirements concerning hospitals with fewer than 100 beds. The pharmacy room or service space shall conform to the requirements of § 1751, Article 7, Division 17, Title 16, California Code of Regulations as enforced by the California Board of Pharmacy.

1224.19.1.1 Handwashing fixture. Handwashing fixture(s) shall be provided within each separate room where open medication is handled.

1224.19.1.2 Location. Provide for convenient access to toilet room and locker.

1224.20 DIETETIC SERVICE SPACE.

1224.20.1 General. Food service facilities and equipment shall conform to these standards, the standards of the National Sanitation Foundation and the requirements of the local public health agency.

1224.20.2 Functional elements. On-site conventional food service preparation shall be provided as follows:

1224.20.2.1 Location. Patient food preparation areas shall have access to delivery, interior transportation, storage, etc., without traversing patient or public circulation. Food preparation, service and storage shall be inaccessible to nondietetic service staff.

1224.20.2.2 Receiving/control stations. Provide an area for the receiving and control of incoming dietary supplies.

1224.20.2.3 Storage spaces. They shall be convenient to the receiving area and shall be located to exclude traffic through the food preparation area to reach them. Storage spaces for bulk, refrigerated, and frozen foods shall be provided. At least one weeks' (7 days) supply of staple foods and at least two (2) days' supply of perishable foods shall be maintained on the premises. Food storage components shall be grouped for convenient access from receiving and to the food preparation areas. All food shall be stored clear of the floor. Lowest shelf shall be not less than 12 inches (305 mm) above the floor or shall be closed in and sealed tight for ease of cleaning.

1224.20.2.4 Cleaning supplies storage. Provide a separate storage room for the storage of nonfood items such as cleaning supplies that might contaminate edibles.

1224.20.2.5 Food preparation workspaces. Provide workspaces for food preparation, cooking, and baking. These areas shall be as close as possible to the user (i.e., tray assembly and dining). Provide additional spaces for thawing and portioning.

1224.20.2.6 Assembly and distribution. Provide a patient tray assembly area and locate within close proximity to the food preparation and distribution areas.

1224.20.2.7 Food service carts. A cart distribution system shall be provided with spaces for storage, loading, distribution, receiving, and sanitizing of the food service carts. Cart circulation shall not be through food preparation areas.

1224.20.2.8 Dining area. Provide dining space(s) for ambulatory patients, staff, and visitors. These spaces shall be separate from the food preparation and distribution areas.

1224.20.2.9 Vending services. If vending devices are used for unscheduled meals, provide a separate room that can be accessed without having to enter the main dining area.

1224.20.2.10 Ware washing facilities. They shall be designed to prevent contamination of clean wares with soiled wares through cross-traffic. The clean wares shall

soiled materials, the clinical sink and handwashing fixture shall be permitted to be omitted. The soiled utility may be shared with an adjacent surgical unit.

1224.28.2.9 Housekeeping room. Shall be a minimum floor area of 15 square feet (1.4 m²). It shall contain a service sink or floor receptor and provisions for storage of supplies and housekeeping equipment. This may be shared with an adjacent surgical unit.

1224.29 INTENSIVE CARE UNITS.

1224.29.1 General. The following shall apply to all types of intensive care service spaces, acute respiratory-care service spaces, burn center spaces, coronary-care service spaces, pediatric intensive-care service spaces unless otherwise noted. Each unit shall comply with the following provisions:

1224.29.1.1 Service space. Each intensive-care unit shall contain not less than four or more than 12 beds.

Exception: When approved by the licensing agency small or rural hospitals intensive care unit may consist of less than four but shall not consist of less than two patient beds.

1224.29.1.2 Patient space. In new construction, each patient space (whether separate rooms, cubicles, or multiple bed space) shall have a minimum of 200 square feet (18.58 m²) of clear floor area with a minimum headwall width of 13 feet (3962 mm) per bed.

Exceptions:

1. Where renovation of existing intensive care units is undertaken, in facilities built under the 2001 or prior California Building Code, patient space (whether separate rooms, cubicles, or multiple bed space) shall have no less than 132 square feet (12.26 m²) with no dimension less than 11 feet (3353 mm), and with 4 feet (1219 mm) of clearance at each side and the foot of the bed, and with a minimum of 8 feet (2438 mm) between beds. The space shall be designed so that all beds shall be placed in relation to the nurses' station or work area to permit, enable or allow maximum observation of patients.
2. For shelled spaces built under the 2001 or prior California Building Code, intensive care units (whether separate rooms, cubicles, or multiple bed space) shall have separate rooms or cubicles for single patient use no less than 132 square feet (12.26 m²) with no dimension less than 11 feet (3353 mm), and with 4 feet (1219 mm) of clearance at each side and the foot of the bed, and with a minimum of 8 feet (2438 mm) between beds. The space shall be designed so that all beds shall be placed in relation to the nurses' station or work area to permit, enable or allow maximum observation of patients.

1224.29.1.3 Private rooms. When private rooms or cubicles are provided, view panels to the corridor shall be required with a means to provide visual privacy. Where

only one door is provided to a bed space, it shall be at least 4 feet (1219 mm) wide and arranged to minimize interference with movement of beds and large equipment. Sliding doors shall not have floor tracks. Where sliding doors are used for access to cubicles within a service space, a 3-foot-wide (914 mm) swinging door may also be provided for personnel communication.

1224.29.1.4 Modular toilet. Modular toilet/sink combination units located within a privacy curtain may be used within each patient space or private room. The toilet fixture shall be completely contained within cabinetry when not in use. Exhaust ventilation requirements shall comply with the California Mechanical Code.

1224.29.1.5 Visitors and visual privacy. Each patient bed area shall have space at each bedside for visitors, and provisions for visual privacy from casual observation by other patients and visitors. For both adult and pediatric units, there shall be a minimum of 8 feet (2438 mm) between beds.

1224.29.1.6 Outside environment. Each patient bed shall have visual access, other than clerestory windows and skylights, to the outside environment with not less than one outside window in each patient bed area.

1224.29.1.6.1 Distance. The distance from the patient bed to the outside window shall not exceed 50 feet (15 240 mm). When partitioned cubicles are used, patients' view to outside windows may be through no more than two separate clear vision panels.

1224.29.1.7 Handwashing fixtures. Handwashing fixtures shall be convenient to nurse stations and patient bed areas. There shall be at least one handwashing fixture for every three beds in open plan areas, and one in each patient room. The handwashing fixture shall be located near the entrance to the patient cubicle or room.

1224.29.1.8 Administrative center or nurse station. This area shall have space for counters and storage. It may be combined with or include centers for reception and communication.

1224.29.1.9 Nurses' work area. There shall be direct visual observation between either a centralized or distributed nurse station or work station and the heads of all patient beds in the intensive care unit.

1224.29.1.10 Monitoring. Each unit shall contain equipment for continuous monitoring. Monitors shall be located to permit easy viewing but not interfere with access to the patient.

1224.29.1.11 Emergency equipment storage. Space that is easily accessible to the staff shall be provided for emergency equipment such as a CPR cart.

1224.29.1.12 Medication station. Shall be provided in accordance with Section 1224.14.2.8.

1224.29.1.13 Airborne infection isolation room. At least one airborne infection isolation room shall be provided per unit. The room shall comply with the requirements of Section 1224.14.3; however, the adjoining toilet room is not required. Modular toilet/sink combination

units located within a privacy curtain may be used. The toilet fixture shall be completely contained within cabinetry when not in use. Exhaust ventilation requirements shall comply with the California Mechanical Code.

Exception: When approved by the licensing agency an airborne infection isolation room is not required for small or rural hospitals.

1224.29.1.14 Additional service spaces. The following additional service spaces shall be immediately available within each intensive care service space. These may be shared by more than one intensive care unit provided that direct access is available from each.

1224.29.1.14.1 Clean utility room. If the room is used for preparing patient care items, it shall contain a work counter, a handwashing fixture, and storage facilities for clean and sterile supplies. If the room is used only for storage and holding as part of a system for distribution of clean and sterile supply materials, the work counter and handwashing fixture may be omitted. Soiled and clean utility rooms or holding rooms shall be separated and have no direct connection.

1224.29.1.14.2 Clean linen storage. There shall be a designated area for clean linen storage. This may be within the clean utility room or a separate closet.

1224.29.1.14.3 Soiled utility room. Size shall be a minimum 50 square feet (4.65 m²); if shared between units, it shall be a minimum of 75 square feet (6.97 m²). The soiled workroom shall contain a clinical sink (or equivalent flushing-rim fixture). The room shall contain a handwashing fixture. The above fixtures shall both have a hot and cold mixing faucet. The room shall have a work counter and space for separate covered containers for soiled linen and a variety of waste types. Rooms used only for temporary holding of soiled material may omit the clinical sink and work counter. If the flushing-rim clinical sink is eliminated, facilities for cleaning bedpans shall be provided elsewhere.

1224.29.1.14.4 Nourishment station. There shall be a nourishment station with sink, work counter, refrigerator, storage cabinets, and equipment for hot and cold nourishments between scheduled meals. The nourishment station shall include space for trays and dishes used for nonscheduled meal service. Provisions and space shall be included for separate temporary storage of unused and soiled dietary trays not picked up at mealtime. Handwashing fixtures shall be in or immediately accessible from the nourishment area.

1224.29.1.14.5 Ice machine. There shall be available equipment to provide ice for treatments and nourishment. Ice-making equipment may be in the clean utility room or at the nourishment station. Ice intended for human consumption shall be from self-dispensing icemakers.

1224.29.1.14.6 Equipment storage room. Appropriate room(s) shall be provided for storage of large items of equipment necessary for patient care. Each intensive care unit shall provide not less than 20 square feet (1.86 m²) per patient bed.

1224.29.1.15 Support. The following shall be provided and shall be located immediately adjacent to the unit:

1. **Visitors' waiting room.**
2. **Office space.**
3. **Staff lounge(s) and toilet room(s).**
4. **Multipurpose room(s).** Provide for staff, patients, and patients' families for patient conferences, reports, education, training sessions, and consultation.
5. **Housekeeping room.** Provide within or immediately adjacent to the intensive care unit. It shall not be shared with other nursing units or departments.
6. **Gurney and wheelchair storage.** Provide a minimum 15 square feet (1.39 m²) per each nursing unit.

1224.29.2 Newborn intensive care units (NICU). The NICU shall comply with all the requirements of Section 1224.29.1. Additionally each NICU shall include or comply with the following:

1224.29.2.1 Entrance. The NICU shall have a clearly identified entrance and reception area for families. The area shall permit visual observation and contact with all traffic entering the unit.

1224.29.2.2 Handwashing fixture(s). Provide one handwashing fixture for each four infants or major fraction thereof. In a multiple-bed room, every bed position shall be within 20 feet (6096 mm) of a handwashing fixture. Where an individual room concept is used, a handwashing fixture shall be provided within each infant care room.

1224.29.2.3 Doors. At least one door to each patient room shall be a minimum of 44 inches (1118 mm) wide.

1224.29.2.4 View windows. When viewing windows are provided, provision shall be made to control casual viewing of infants. Controls shall be provided to enable lighting to be adjusted over individual patient care spaces. Darkening sufficient for transillumination shall be available when necessary.

1224.29.2.5 Control station. A central area shall serve as a control station, shall have space for counters and storage, and shall have convenient access to handwashing fixture. It may be combined with or include centers for reception and communication and patient monitoring.

1224.29.2.6 Area. Each patient care space shall contain a minimum of 120 square feet (11.15 m²) per bassinets excluding handwashing fixtures and aisles. There shall be an aisle for circulation adjacent to each patient care space with a minimum width of 4 feet (1219 mm).

Exceptions:

1. Where renovation of existing NICUs is undertaken in facilities built under the 2001 or prior California Building Code, patient care areas shall have no less than 80 square feet (7.43 m²) of clear floor area per bassinet exclusive of space for nurse control, scrubbing and gowning, and reception area.
2. For shelled spaces built under the 2001 or prior California Building Code, NICUs shall have no less than 80 square feet (7.43 m²) of clear floor area per bassinet, exclusive of space for nurse control, scrubbing and gowning, and reception area.

1224.29.2.7 Ceilings. Ceilings shall have a noise reduction coefficient (NRC) of at least 0.90.

1224.29.2.8 Airborne infection isolation room. Shall comply with the requirements of Section 1224.29.1.13 except for separate toilet, bathtubs, or shower. The room shall be enclosed and separated from the nursery unit with provisions for observation of the infant from adjacent nurseries or control area(s).

1224.29.2.9 Lactation. Space shall be provided for lactation support and consultation in or immediately adjacent to the NICU.

1224.29.2.10 Emergency equipment storage. Space shall be provided for emergency equipment that is under direct control of the nursing staff, such as a CPR cart.

1224.29.2.11 Housekeeping room. Shall be directly accessible from the unit and be dedicated for the exclusive use of the neonatal intensive care unit.

1224.29.2.12 Daylight. At least one source of daylight shall be visible from newborn care areas.

1. External windows in infant care rooms shall be glazed with insulating glass to minimize heat gain or loss.
2. External windows in infant care rooms shall be situated at least 2 feet (60.96 centimeters) away from any part of a baby's bed to minimize radiant heat loss from the baby.
3. All external windows shall be equipped with easily cleaned shading devices that are neutral color or opaque to minimize color distortion from transmitted light.

1224.30 PEDIATRIC AND ADOLESCENT UNIT. A pediatric nursing unit shall be provided if the hospital has eight or more licensed pediatric beds. The unit shall meet the following standards:

1224.30.1 Patient rooms. Each patient room shall meet the following standards:

1224.30.1.1 Beds. The space requirements for pediatric patient beds shall be the same as required by Section 1224.14.1.2.

1224.30.1.2 Windows. Each patient room shall have a window in accordance with Section 1224.4.9.

1224.30.2 Examination or treatment rooms. This room shall be provided for pediatric and adolescent patients. A separate area for infant examination and treatment may be provided within the pediatric nursery workroom.

1224.30.3 Service areas. The service areas in the pediatric and adolescent nursing units shall conform to Section 1224.14.2 and shall also provide the following:

1224.30.3.1 Play area. A play area shall be provided.

1224.30.3.2 Infant formula. Space for preparation and storage of infant formula shall be provided within the unit or other convenient location.

1224.30.3.3 Toilet rooms. Patient toilet room(s) with a lavatory in each room, in addition to those serving bed areas, shall be conveniently located to play area(s) and to each central bathing facility.

1224.30.3.4 Storage. Closets or cabinets for toys, educational, and recreational equipment shall be provided.

1224.30.3.5 Airborne infection isolation room. At least one airborne infection isolation room shall be provided within each pediatric unit; minimum of one per 15 beds. Airborne infection isolation room(s) shall comply with the requirements of Section 1224.14.3.

1224.30.3.6 Clean and soiled workrooms. Separate clean and soiled workrooms or holding rooms shall be provided as described in Sections 1224.14.2.6 and 1224.14.2.7.

1224.31 PSYCHIATRIC NURSING UNIT.

1224.31.1 Psychiatric unit space. A psychiatric unit shall be housed in a separate and distinct nursing unit and shall provide the following:

1224.31.1.1 General. A psychiatric nursing unit shall meet the requirements of Section 1224.14.

1224.31.1.2 Windows. Windows modified to prevent patients from leaving the unit.

1224.31.1.3 Access control. Entrances and exits which may be locked if necessary.

1224.31.1.4 Observation room(s). Used for the observation of acutely disturbed patients. This room shall be designed to allow visual observation and be located near the nursing station and a bathroom.

1224.31.1.5 Consultation room(s). Used for interview-ing patients.

1224.31.1.6 Dining and recreation. Provide spaces for dining and recreation. The total area for these purposes shall be not less than 30 square feet (2.8 m²) per patient.

1224.31.1.7 Storage. Storage closets or cabinets for recreational and occupation therapy equipment.

1224.31.1.8 Exam or treatment room. A room for physical examinations and medical treatment.

1224.31.1.9 Activity spaces. Indoor and outdoor space for therapeutic activities.

1224.31.1.10 Occupational therapy. Facilities for occupational therapy shall comply with Section 1224.35.3.

1224.31.1.11 Recreation. A recreation room with a minimum of 100 square feet (9.3 m²) in each building, and on each floor of a building accommodating six or more psychiatric patients.

1224.31.1.12 Nurse call. A nurses' call system is not required, but if it is included, provisions shall be made for easy removal, or for covering call button outlets.

1224.31.1.13 Privacy. Visual privacy in multibed rooms (e.g., cubicle curtains) is not required.

1224.31.1.14 Tamper resistant. The ceiling and the air distribution devices, lighting fixtures, sprinkler heads, and other appurtenances shall be of a tamper-resistant type.

1224.31.1.15 Toilet rooms. Each patient room shall be provided with a private toilet room that meets the following requirements:

1. The door shall not be lockable from within.
2. The door shall be capable of swinging outward.
3. The ceiling shall be of tamper-resistant construction and the air distribution devices, lighting fixtures, sprinkler heads, and other appurtenances shall be of the tamper-resistant type.

1224.31.2 Education. If a unit treats children of school age over a period of one month or more, it shall provide physical facilities for an educational program, such as classrooms and an office for the teacher.

1224.31.3 Service areas The standards noted in Section 1224.14.2 shall apply to service areas for psychiatric nursing units.

1224.32 OBSTETRICAL FACILITIES (PERINATAL UNIT SPACE)

1224.32.1 General. The obstetrical facility, including cesarean operating room(s) and delivery room(s), shall be located and designed to prohibit nonrelated traffic through the unit.

1224.32.2 Antepartum and postpartum unit

1224.32.2.1 Patient bedrooms. Antepartum and postpartum bedrooms shall comply with Section 1224.14.1.

1224.32.2.2 Service areas. Shall be provided in accordance with Section 1224.14.2 with the following additions:

1. Staff lounge.
2. Staff storage. Lockable closets or cabinets for personal articles of staff.
3. Consultation/conference room(s).

1224.32.3 Cesarean/delivery service space

1224.32.3.1 Cesarean operating room(s). Provide a minimum clear floor area of 360 square feet (33.45 m²) with a minimum dimension of 16 feet (4877 mm). There shall be a minimum of one such room.

1224.32.3.2 Delivery room(s). Provide a minimum clear floor area of 300 square feet (27.87 m²). An emergency communication system shall be connected with the

obstetrical facilities control station. There shall be a minimum of one such room.

1224.32.3.2.1 Postpartum bed ratio. Delivery rooms, which are used for no other purpose, shall be provided at the ratio of one per 12 postpartum beds or major fraction thereof.

Exceptions:

1. If LDR or LDRP beds are provided, each LDR or LDRP may be counted as a delivery room in the postpartum bed ratio.
2. When approved by the licensing agency, the operating room of small or rural hospitals with a licensed bed capacity of 50 or less may serve as the delivery room.

1224.32.3.3 Clocks. Shall be provided as follows:

1. A direct-wired or battery-operated clock with sweep second hand and lapsed time indicators in each cesarean operating and delivery room.
2. A direct-wired or battery-operated clock or other equivalent timing device, visible from the scrub-up sinks.

1224.32.3.4 Surgical lights. Provide a surgical light in each cesarean operating or delivery room.

1224.32.3.5 Infant resuscitation. Provide within the cesarean operating rooms and delivery rooms a minimum clear floor area of 40 square feet (3.72 m²) in addition to the required area of each room or may be provided in a separate but immediately accessible room with a clear floor area of 150 square feet (13.94 m²). Six single or three duplex electrical outlets shall be provided for the infant in addition to the facilities required for the mother.

1224.32.3.6 Labor room(s) (LDR or LDRP rooms may be substituted). Where LDRs or LDRPs are not provided, a minimum of two labor beds shall be provided for each cesarean operating room. Each room shall be designed for either one or two beds with a minimum clear floor area of 120 square feet (11.15 m²) per bed. Each labor room shall contain a handwashing fixture and have access to a toilet room. One toilet room may serve two labor rooms. Labor rooms shall have controlled access with doors that are arranged for observation from a nursing station. At least one shower (which may be separate from the labor room if under staff control) for use of patients in labor shall be provided. Windows in labor rooms, if provided, shall be located, draped, or otherwise arranged, to preserve patient privacy from casual observation from outside the labor room.

Exceptions:

1. Where renovation of labor rooms is undertaken in facilities built under the 2001 or prior California Building Code, existing labor rooms shall have a minimum clear floor area of 100 square feet (9.29 m²) per bed.
2. For shelled spaces built under the 2001 or prior California Building Code, labor rooms shall have a minimum clear floor area of 100 square feet (9.29 m²) per bed.

control of access to treatment area, pedestrian and ambulance entrances, and public waiting area.

1224.33.3.4 Wheelchair and gurney storage. Shall be located with convenient access from emergency entrances.

1224.33.3.5 Public waiting area with toilet room facilities, drinking fountains, and telephone.

1224.33.3.6 Examination or treatment room(s). Shall have a minimum floor area of 120 square feet (11.15 m²). The room shall contain work counter(s); cabinets; handwashing fixtures; and a vision panel adjacent to and/or in the door. When treatment cubicles are in open multi-bed areas, each cubicle shall have a minimum of 80 square feet (7.43 m²) of clear floor space with a minimum 8 foot (2438 mm) width and 3 feet (914 mm) at foot of bed and shall be separated from adjoining cubicles by curtains. Handwashing fixtures shall be provided for each four treatment cubicles or major fraction thereof in multiple-bed areas.

Exceptions:

1. Where renovation of existing examination or treatment room(s) is undertaken in facilities built under the 2001 or prior California Building Code, patient rooms shall have no less than 80 square feet (7.43 m²) of clear floor area per examination or treatment room(s).
2. For shelled spaces built under the 2001 or prior California Building Code, examination or treatment room(s) shall have no less than 80 square feet (7.43 m²) of clear floor area.

1224.33.3.7 Trauma/cardiac rooms. These rooms are for emergency procedures, including emergency surgery, and shall have at least 250 square feet (23.23 m²) of clear floor space. Each room shall have cabinets and emergency supply shelves, image viewing capability, examination lights, and counter space for writing. Additional space with cubicle curtains for privacy may be provided to accommodate more than one patient at a time in the trauma room. There shall be storage provided for immediate access to attire used for universal precautions. Doors leading from the ambulance entrance to the cardiac trauma room shall have an opening with a minimum width of 5 feet (1524 mm).

1224.33.3.8 Orthopedic and cast work. Provisions may be made in separate room(s) or in the trauma room. They shall include storage for splints and other orthopedic supplies, traction hooks, image viewing capability, and examination lights. If a sink is used for the disposal of plaster of paris, a plaster trap shall be provided. The clear floor space for this area shall be a minimum of 180 square feet (16.7 m²)

1224.33.3.9 Poison Control Center and EMS communications center. May be a part of the staff work and charting area.

1224.33.3.10 Emergency equipment storage space.

1224.33.3.11 Patients' toilet room. Where there are more than eight treatment areas, a minimum of two toilet

rooms, with a lavatory in each toilet room, shall be required.

1224.33.3.12 Storage. Provide rooms for clean, soiled, or used supplies.

1224.33.3.12.1 Soiled workroom or soiled holding room. See Section 1224.14.2.7. This room is for the exclusive use of the emergency service.

1224.33.3.12.2 Clean utility room. See Section 1224.14.2.6.

1224.33.3.13 Administrative center or nurses' station for staff work and charting. These areas shall have space for counters, cabinets, and medication storage, and shall have convenient access to handwashing fixtures. They may be combined with or include centers for reception and communication.

1224.33.3.14 Staff lounge.

1224.33.3.15 Housekeeping room. A housekeeping room shall be directly accessible from the unit.

1224.33.3.16 Airborne infection isolation room. If provided shall comply with the requirements of Section 1224.29.1.13 except for separate toilet room, bathtubs, or shower.

1224.33.3.17 Secured holding room. If provided, shall have at least one holding/seclusion room of 120 square feet (11.15 m²). This room shall allow for security, patient and staff safety, patient observation, and sound-proofing.

1224.33.4 Other space considerations

1224.33.4.1 Observation units. If provided shall have the following:

1. Handwashing fixtures shall be provided for each four treatment cubicles or major fraction thereof. Handwashing fixtures shall be convenient to nurse stations and patient bed areas.
2. Each patient bed area shall have space at each bedside for visitors and provision for visual privacy from casual observation by other patients and visitors.
3. One toilet room shall be provided for each eight treatment cubicles or major fraction thereof.
4. A sink, work counter, refrigerator, storage cabinets.

1224.34 NUCLEAR MEDICINE

1224.34.1 General. If nuclear medicine is provided, the following shall be provided:

1224.34.1.1 Radiation protection. A certified physicist shall specify the type, location, and amount of radiation protection to be installed in accordance with final approved department layout and equipment selection. Radiation protection requirements shall be incorporated into the construction documents and comply with Chapter 31C and the requirements of California Radiation Control Regulations, California Code of Regulations, Title 17, Division 1, Chapter 5, and Subchapter 4.

1224.34.1.2 Nuclear medicine room. Sized to accommodate the equipment and a gurney. Provide a handwashing fixture.

1224.34.1.3 Radiopharmacy. If radiopharmaceutical preparation is performed, an area adequate to house a radiopharmacy shall be provided with appropriate shielding. This area shall include adequate space for storage of radionuclides, chemicals for preparation, dose calibrators, and record keeping. If preprepared materials are used, storage and calculation area may be considerably smaller than that for on-site preparation. Space shall provide adequately for dose calibration, quality assurance, and record keeping. The area may still require shielding from other portions of the facilities.

1224.34.2 Services. Nuclear medicine area when operated separately from the imaging department shall provide the following:

1224.34.2.1 Entrance. Space shall be adequate to permit entry of gurneys, beds, and able to accommodate imaging equipment, electronic consoles, and if present, computer terminals.

1224.34.2.2 Cleanup. Provisions for cleanup shall be located within the service space for convenient access and use. It shall include service sink or floor receptacle as well as storage space for equipment and supplies.

1224.34.2.3 Consultation. A consultation area may be provided.

1224.34.2.4 Waiting. Waiting areas shall be provided out of traffic, under staff control. If the department is routinely used for outpatients and inpatients at the same time, separate waiting areas shall be provided with screening or visual privacy between the waiting areas.

1224.34.2.5 Dose administration area. Provide and locate near the preparation area. Since as much as several hours may elapse for the dose to take effect, the area shall provide for visual privacy from other areas.

1224.34.2.6 Holding. A holding area for patients on gurneys or beds shall be provided out of traffic and under control of staff and may be combined with the dose administration area with visual privacy between the areas.

1224.34.2.7 Patient dressing rooms. Located convenient to the waiting area and procedure rooms. Each dressing room shall include a seat or bench, a mirror, and provisions for hanging patients' clothing and for securing valuables.

1224.34.2.8 Patient toilet room(s). Reserved for nuclear medicine patients and shall be located convenient to waiting and procedure rooms.

1224.34.2.9 Staff toilet rooms(s). Shall be located convenient to the nuclear medicine laboratory.

1224.34.2.10 Handwashing fixtures. Shall be located within each procedure room.

1224.34.2.11 Control desk and reception.

1224.34.2.12 Storage area for clean linen.

1224.34.2.13 Soiled and contaminated material. Provisions with handwashing fixtures shall be made for holding soiled material. Separate provisions shall be made for holding contaminated material.

1224.34.3 Radiotherapy service space.

1224.34.3.1 Radiation therapy space. If radiation therapy is provided, the following shall be accommodated:

1. Patient reception and waiting areas.
2. Space for medical and physics staff functions.
3. Space for equipment and supplies.
4. Housekeeping room.
5. Direct access to or space provided for radiation measurement and calibration equipment, including a calibration constancy instrument, and access to a secondary standard dose meter.

5.1. A megavoltage treatment unit capable of delivering x-rays or gamma rays of effective energy 500 KeV or more and conforming to the requirements of Chapter 31C and the California Radiation Control Regulations, California Code of Regulations, Title 17, Division 1, Chapter 5, Subchapter 4.

5.2. Access to a medium voltage or superficial treatment unit delivering 500 KeV or less, but otherwise having the same functional characteristics as the above mega-voltage units and conforming to the requirements of Chapter 31C and the California Radiation Control Regulations, California Code of Regulations, Title 17, Division 1, Chapter 5, Subchapter 4.

5.3. Direct access to or space provided for brachytherapy equipment which shall meet the requirements of Chapter 31C and the California Radiation Control Regulations, California Code of Regulations, Title 17, Division 1, Chapter 5, Subchapter 4.

5.4. Shielding of the rooms shall meet the requirements of Chapter 31C and the California Radiation Control Regulations, California Code of Regulations, Title 17, Division 1, Chapter 5, Subchapter 4.

1224.34.3.2 Radiation protection. Cobalt, linear accelerators, hot lab and high dose rate brachytherapy rooms and simulation rooms require radiation protection. All rooms that provide radiation treatment shall be appropriately shielded. A certified physicist shall specify the type, location, and amount of protection to be installed in accordance with final approved department layout and equipment selection. Radiation protection requirements shall be incorporated into the construction documents and comply with Chapter 31C and the requirements of California Radiation Control Regulations, California Code of Regulations, Title 17, Division 1, Chapter 5, and Subchapter 4.

1224.34.3.3 Room sizes. Rooms shall be sized as follows:

1. Cobalt rooms and linear accelerators shall be sized in accordance with equipment requirements and shall accommodate a gurney for litter borne patients. Layouts shall provide for preventing the escape of radioactive particles. Openings into the room, including doors, ductwork, vents and electrical raceways and conduits, shall be baffled to prevent direct exposure to other areas of the facility.
2. Simulator, accelerator, and cobalt rooms shall be sized to accommodate the equipment with patient access on a gurney, medical staff access to the equipment and patient, and service access.

1224.34.3.4 General support area. The following areas shall be provided:

1. A gurney hold area adjacent to the treatment rooms, screened for privacy, and combined with a seating area for outpatients.
2. Exam or treatment room shall be provided with a minimum of 100 square feet (9.29 m²) with a minimum dimension of 8 feet (2438 mm). Each exam room shall be equipped with a handwashing fixture.

Exceptions:

1. Where renovation of existing treatment rooms is undertaken in facilities built under the 2001 or prior California Building Code, treatment rooms shall have no less than 80 square feet (7.43 m²) of clear floor area.
2. For shelled spaces built under the 2001 or prior California Building Code, treatment rooms shall have no less than 80 square feet (7.43 m²) of clear floor area per bed.
3. Darkroom is optional. If provided, shall be convenient to the treatment room(s)
4. Patient gowning area with provision for safe storage of valuables and clothing and with direct access to toilet room(s). At least one space shall be large enough for staff-assisted dressing.
5. Film files area is optional. If provided shall have storage for unprocessed film.

1224.34.4 Additional support areas for linear accelerator.

1224.34.4.1 Mold room with exhaust hood and handwashing fixture.

1224.34.4.2 Block room with storage. The block room may be combined with the mold room.

1224.34.5 Additional support areas for cobalt room.

1224.34.5.1 Hot lab.

1224.34.6 High dose rate brachytherapy room.

1224.35 REHABILITATION THERAPY DEPARTMENT

1224.35.1 Rehabilitation center space. If provided, a rehabilitation center space shall be designed to meet the requirements of Section 1224.14, except as follows:

1. Patient bedrooms shall contain a minimum of 110 square feet (10.22 m²) of clear floor area per bed,

exclusive of toilet room(s), closets, lockers, wardrobes, alcoves or vestibules, with greater space provided for special needs such as circ-o-electric beds.

2. Space for group dining shall be provided at the minimum rate of 20 square feet (1.86 m²) per bed.
3. Space for group recreation or patient's lounge shall be provided at the minimum rate of 20 square feet (1.86 m²) per bed.
4. Space for staff conferences, patient evaluation, and progress reports.
5. A classroom space.
6. An examination and treatment room, adjacent or directly accessible to an office for the physician in charge of the outpatient service.
7. A patient waiting area with access to telephone, drinking fountain, and men's and women's toilet room facilities in or adjacent to the rehabilitation outpatient service area.
8. Access to an outside area to be used for therapeutic procedures for patients.
9. At least one training toilet room in each patient unit with minimum dimensions of 5 feet by 6 feet (1524 mm by 1829 mm).
10. Patient bathtubs, where provided, of standard height and located to provide access to both sides and one end of the tub.
11. Patient showers, where provided, shall have a minimum floor area of 16 square feet (1.49 m²), no dimension of which shall be less than 4 feet (1219 mm), be equipped with handrails, privacy curtains, and designed for ease of accessibility. The floor shall be sloped to provide drainage.

1224.35.2 Physical therapy service space. If physical therapy is part of the service, the following shall be included:

1. Individual treatment area(s) with privacy screens or curtains. Each such space shall have not less than 70 square feet (6.51 m²) of clear floor area.
2. Handwashing fixtures for staff either within or at each treatment space. (One handwashing fixture may serve several treatment stations.)
3. Exercise area and facilities.
4. Clean linen and towel storage.
5. Storage for equipment and supplies.
6. Separate storage for soiled linen, towels, and supplies.

Exception: When approved by the licensing agency small or rural hospitals are exempt from Sections 1224.35.2.1 through 1224.35.2.6.

1224.35.3 Occupational therapy service space. If this service is provided, the following shall be included:

1. Work areas and counters suitable for wheelchair access.
2. Handwashing fixture(s).
3. Storage for supplies and equipment.
4. An area for teaching daily living activities shall be provided. It shall contain an area for a bed, kitchen

counter with appliances and sink, bathroom, and a table/chair.

1224.35.4 Speech pathology and/or audiology service space. If a speech pathology service is provided, space shall be provided for:

1. Tables and chairs to conduct interviews, consultations and treatment, and to accommodate patients in wheelchairs and stretchers.
2. A waiting area with access to public toilet room(s) if outpatients are being served.
3. Handwashing fixture.
4. Testing unit. If an audiology service is provided, there shall be, in addition to Items 1, 2 and 3 above, a minimum of one two-room testing unit that meets Standards S-3.1, 1960 (R-1971), *Criteria for Background Noise in Audiometer Rooms*, of the American National Standards Institute, Inc., 1430 Broadway, New York, NY 10018.

1224.36 RENAL DIALYSIS SERVICE SPACE (ACUTE AND CHRONIC)

1224.36.1 General. If provided, renal dialysis service shall comply with the following:

1224.36.2 Treatment area.

1224.36.2.1 Location. The treatment area may be an open area and shall be separate from administrative and waiting areas.

1224.36.2.2 Nurses' station(s). Shall be located within the dialysis treatment area and designed to provide visual observation of all patient stations.

1224.36.2.3 Individual patient treatment areas. Shall contain at least 80 square feet (7.44 m²). There shall be at least a 4-foot (1219 mm) space around and between beds and/or lounge chairs.

1224.36.2.4 Handwashing fixtures. Shall be located convenient to the nurses' station and patient treatment areas. There shall be at least one handwashing fixture serving no more than four stations. These shall be uniformly distributed to provide equal access from each patient station.

1224.36.2.5 Privacy. The open unit shall be designed to provide privacy for each patient.

1224.36.2.6 Bloodborne infection isolation room. A minimum of one bloodborne infection isolation room of at least 120 square feet (11.15 m²) of clear floor space shall be provided for patients. This room shall contain a counter and handwashing fixture.

1224.36.2.7 Medication dispensing. If provided, there shall be a medication dispensing station for the dialysis center. A work counter and handwashing fixtures shall be included in this area. Provisions shall be made for the controlled storage, preparation, distribution and refrigeration of medications.

1224.36.2.8 Home training. If provided in the unit, a private treatment area of at least 120 square feet (11.15 m²) shall be provided for patients who are being trained to use dialysis equipment at home. This room shall contain

counter, handwashing fixtures, and a separate drain for fluid disposal.

1224.36.2.9 Examination room. An examination room with a handwashing fixture shall be provided with at least 100 square feet (9.29 m²).

1224.36.2.10 Clean utility room. A clean utility room shall be provided. If the room is used for preparing patient care items, it shall contain a work counter, a handwashing fixture, and storage facilities for clean and sterile supplies. If the room is used only for storage and holding as part of a system for distribution of clean and sterile materials, the work counter and handwashing fixture may be omitted. Soiled and clean utility rooms or holding rooms shall be separated and have no direct connection.

1224.36.2.11 Soiled utility room. A soiled workroom shall be provided and contain a sink, handwashing fixture, work counter, storage cabinets, waste receptacles, and a soiled linen receptacle.

1224.36.2.12 Reprocessing room. If dialyzers are reused, a reprocessing room is required and sized to perform the functions required and include one-way flow of materials from soiled to clean with provisions for a refrigerator (temporary storage or dialyzer), decontamination/cleaning areas, sinks, processors, computer processors and label printers, packaging area and dialyzer storage and disinfectants cabinets.

1224.36.2.13 Nourishment station. If a nourishment station for the dialysis service is provided, the nourishment station shall contain a sink, a work counter, a refrigerator, storage cabinets and equipment for serving nourishments as required.

1224.36.2.14 Housekeeping room. Provide adjacent to and for the exclusive use of the unit.

1224.36.2.15 Repair room. If required, an equipment repair and breakdown room shall be equipped with a handwashing fixture, deep service sink, work counter and storage cabinet. Needs water supply and drain connection for testing machines.

1224.36.2.16 Supplies. Supply areas or supply carts shall be provided.

1224.36.2.17 Storage. Storage space shall be available for wheelchairs and gurneys, if gurneys are provided, out of direct line of traffic.

1224.36.2.18 Clean linen storage A clean linen storage area shall be provided. This may be within the clean utility room, a separate closet, or an approved distribution system. If a closed cart system is used, storage may be in an alcove. It must be out of the path of normal traffic and under staff control.

1224.36.2.19 Mixing room. Each facility using a central batch delivery system shall provide, either on the premises or through written arrangements, individual delivery systems for the treatment of any patient requiring special dialysis solutions. The mixing room shall also include a sink, storage space and holding tanks.

1224.36.2.20 Water treatment room. The water treatment equipment shall be located in an enclosed room.

1224.36.2.21 Patient toilet. A patient toilet room with a lavatory shall be provided.

1224.36.3 Ancillary facilities.

1224.36.3.1 Staff lounge, lockers and toilet(s). Space shall be available for male and female personnel for staff clothing change area and lounge. The areas shall contain lockers, shower, toilet(s), and handwashing fixtures.

1224.36.3.2 Patient storage. Storage for patients' belongings shall be provided.

1224.36.3.3 Waiting room. A waiting room, toilet room(s) with handwashing fixtures, drinking fountain, public telephone, and seating accommodations for waiting periods shall be available or accessible to the dialysis unit.

1224.36.3.4 Administrative services. Provide office and clinical work space.

1224.37 RESPIRATORY THERAPY SERVICE SPACE. If respiratory service is provided, the following elements shall be included:

1. **Storage for equipment and supplies.**
2. **Space and utilities for cleaning and disinfecting equipment.** Provide physical separation of the space for receiving and cleaning soiled materials from the space for storage of clean equipment and supplies. Appropriate local exhaust ventilation shall be provided if gluteraldehyde or other noxious disinfectants are used in the cleaning process. This space may be co-located with other reprocessing functions within the hospital.
3. **Additional facilities.** If respiratory services such as testing and demonstration for outpatients are part of the program, additional facilities and equipment shall be provided including but not limited to:
 - 3.1. Patient waiting.
 - 3.2. A reception and control station.

1224.38 INTERMEDIATE-CARE SERVICE SPACE. An intermediate-care service unit shall be housed in a separate and distinct nursing unit and shall comply with the applicable requirements of Section 1225.

1224.39 OUTPATIENT SERVICE SPACE.

1224.39.1 Waiting area(s). Provide with access to public toilet room facilities, a public telephone and a drinking fountain. These facilities may be shared with other services.

1224.39.2 Outpatient surgery. If outpatient surgery is performed in the out patient service area, the following shall be provided:

1. An operating room(s) with a minimum clear floor area of 270 square feet (25.08 m²), no dimension of which shall be less than 15 feet (4572 mm).
2. Preoperative patient holding shall be provided in accordance with Section 1224.15.2.
3. A postanesthesia recovery area which meets the requirements of Section 1224.16.

4. Each surgical unit shall provide a separate cleanup room separated from any surgical sterilizing facilities. The cleanup room shall provide 24 square feet (2.2 m²) per operating room up to eight operating rooms and shall have the minimum area of 48 square feet (4.5 m²), with no dimension less than 6 feet (1829 mm).
5. Scrub sinks which meet the requirements of Section 1224.15.3.5.
6. Service areas which meet the requirements of Section 1224.15.3.
7. A housekeeping room shall be provided for the exclusive use of outpatient surgery. It shall be directly accessible from the service area.

1224.39.3 Endoscopy rooms. If endoscopy examination rooms are provided, each room shall be a minimum of 200 square feet (18.6 m²) and have a handwashing fixture.

1224.40 SKILLED NURSING SERVICE SPACE. If provided a skilled nursing service unit shall be housed in a separate and distinct nursing unit and shall comply with the applicable requirements of Section 1225.

1224.41 SOCIAL SERVICE SPACE. If provided, the social service space shall include office or other space for privacy in interviewing, telephoning and conducting conferences.

**SECTION 1225 [OSHPD 2]
SKILLED NURSING AND INTERMEDIATE-CARE
FACILITIES**

1225.1 Scope. The provisions of this section shall apply to skilled nursing and intermediate-care facilities, including distinct part skilled nursing and intermediate care services on a general acute-care or acute psychiatric hospital license, provided either in a separate unit or a freestanding building.

1225.2 Application. New buildings and additions, alterations or repairs to existing buildings subject to licensure shall comply with applicable provisions of the California Electrical Code, California Mechanical Code and California Plumbing Code, Parts 3, 4 and 5 of Title 24 and this section.

Exception: See Section 1224.2.

1225.3 General construction. Skilled nursing and intermediate-care facilities shall comply with Sections 1224.4 through 1224.13 whenever applicable.

1225.4 NURSING SERVICE SPACE.

1225.4.1 Patient bedrooms. Patients shall be accommodated only in rooms with the following minimum floor area, exclusive of toilet rooms, wardrobes, entrance vestibules, and fixed furnishings or equipment.

1. Single-patient rooms: 110 square feet (10.21 m²).
2. Multipatient rooms: 80 square feet (7.43 m²) per bed.

1225.4.2 Bed clearance. A minimum distance of 3 feet (914 mm) shall be provided between beds and 4 feet (1219 mm) between the foot of beds and walls or fixed objects in multipatient rooms, and 3 feet (914 mm) in single-patient rooms.

1225.4.3 Patient room beds. Patient rooms shall not be designed to permit the placement of beds more than three

deep from the exterior window, but shall be of such shape and dimensions to allow for the performance of routine functions, including the easy transfer of patients to and from bed to wheelchair or wheeled stretcher. No patient room shall be designed to accommodate more than four beds.

1225.4.4 Outside exposure. All patient bedrooms shall have an outside exposure and shall not be below ground level.

1225.4.5 Patient storage. Each patient room shall be provided with wardrobe or locker spaces for clothing, toilet articles or other personal belongings for each patient.

Exception: Pediatric and psychiatric patient rooms.

1225.4.6 Airborne infection isolation rooms. If provided, single rooms shall be provided for the isolation of patients with airborne communicable disease. Airborne infection isolation rooms shall be labeled with the words "Airborne Infection Isolation Room" on or adjacent to the anteroom side of the door between the isolation room and the anteroom.

Exception: Alternate designs for modifications to isolation rooms in operation prior to the effective date of this section may be utilized when it can be demonstrated that the alternate design meets performance requirements, without compromising any health or life safety requirement.

1225.4.6.1 Anteroom. A separate anteroom shall be provided between the airborne infection isolation room and the corridor, which shall constitute the primary entrance to the airborne infection isolation room. This anteroom shall have a handwashing fixture, work counter at least 3 feet (914 mm) long, cabinets and space to gown and to store clean and soiled materials. There shall be a view window from the anteroom to the isolation room and means to allow for airflow from the anteroom into the airborne infection isolation room. Doors shall be aligned to allow large equipment to be wheeled into the airborne infection isolation room unless a secondary door complying with Section 1225.4.6.2 is provided. One anteroom may serve no more than two airborne infection isolation rooms.

1225.4.6.2 Secondary entry. When a secondary entry is provided directly from the hallway to the airborne infection isolation room, it shall be a tight-fitting smoke-and draft-control assembly. In addition, an approved gasket shall be installed to provide a seal at the bottom of the door. Secondary doors shall be provided with locking devices which are readily operable from the room side and which are readily operable by the facility staff on the other side. When key locks are used on isolation rooms, keys shall be located at the nurses' station in a prominent readily accessible location.

1225.4.6.3 Sealed-tight room. Airborne infection isolation room perimeter walls, ceiling, floors, doors, and penetrations shall be sealed tightly to minimize air infiltration from the outside or from other spaces.

1225.4.6.4 Adjoining toilet room. Each isolation room shall have its own adjoining toilet room with an emer-

gency nurse call system, a lavatory, a shower providing a seat or a space for a shower chair and a toilet equipped with a bedpan flushing attachment with a vacuum breaker.

1225.4.7 Protective environment room(s). Protective environment rooms for the protection of certain immunosuppressed patients may be provided by the facility. Protective environment rooms shall be labeled "Protective Environment Room" on or adjacent to the anteroom side of the door between the protective environment room and the anteroom.

1225.4.7.1 Anteroom. A separate anteroom shall be provided between the protective environment room and the corridor, hallway or adjoining space which shall constitute the only entrance to the protective environment room. This anteroom shall have a handwashing fixture, work counter at least 3 feet (914 mm) long, cabinets and space to gown and to store clean and soiled materials. There shall be a view window from the anteroom to the protective environment room. There shall be means to allow for airflow from the protective environment room into the anteroom. Anteroom doors shall be aligned so that large equipment can be wheeled into the protective environment room. One anteroom may serve no more than one protective environment room.

Exception: Alternate designs for positive protective environment rooms, without individual anterooms, may be approved by the enforcement agency when it can be demonstrated that the alternate design meets the requirements of the California Mechanical Code and does not compromise or alter any health or fire protection component, assembly or system.

1225.4.7.2 Adjoining toilet room. Room shall meet the requirements of Section 1225.4.6.4.

1225.4.7.3 Sealed-tight room. Airborne infection isolation room perimeter walls, ceiling, floors, doors, and penetrations shall be sealed tightly to minimize air infiltration from the outside or from other spaces.

1225.4.8 Room identification. Each patient room shall be labeled with an identification number, letter, or combination of the two.

1225.4.9 Nurses' station. A nurses' station in free-standing skilled nursing and intermediate-care facilities shall be provided within each nursing unit. Nurses' stations shall be designed to serve no more than 60 beds.

Exception: The 60-bed limit does not apply to distinct part skilled nursing and intermediate-care services provided as a separate unit in a general acute-care hospital or acute psychiatric hospital.

1225.4.9.1 Components. Nurses' stations shall be provided with a cabinet, a desk, space for records, a bulletin board, a telephone, and a specifically designated, lockable and illuminated medicine storage compartment, and a handwashing fixture. If a separate medicine room is provided, it shall have a lockable door and a sink. This sink cannot replace the required nurses' station handwashing fixture.

shall accommodate the following services and equipment:

1. Soiled work area. A receiving and gross cleaning area which shall contain work space and equipment for cleaning medical and surgical equipment and for disposal of or processing of soiled material.
2. Clean work area. A clean work area which shall contain work space and equipment for sterilizing medical and surgical equipment and supplies.
3. Sterilizing space.
4. Storage. Space for sterile supplies and unsterile supplies.

1225.9.2.2 Sterilizers. All sterilizers and autoclaves which emit steam exhaust shall be vented to the outside of the building. Such vents shall be independent from the plumbing vent system.

Exception: Small instrument sterilizers.

1225.10 STORAGE.

1225.10.1 Required areas. Facilities shall provide combined general and specialized storage in accordance with the following schedule:

Licensed Bed Capacity	Storage Area
1 to 10 beds	120 square feet (11.15 m ²) minimum
11 to 100 beds	12 square feet (1.11 m ²) per bed
Over 100 beds	1,200 square feet (111.48 m ²) plus 5 square feet (0.46 m ²) per bed for each bed over 100

1225.10.2 Specialized storage. Shall include those spaces identified in the dietetic food storage of Section 1225.5 and as follows:

1225.10.2.1 Linen. Separate and enclosed facilities for clean and soiled linen in each nursing unit. The clean linen storage space shall have a minimum area of 10 square feet (0.93 m²) and may be within the clean utility room. The soiled linen collection space shall have an area of no less than 10 square feet (0.93 m²), except where linen chutes are provided, and may be within the soiled utility room.

1225.10.2.2 Supply. One supply storage space having a minimum area of 15 square feet (1.39 m²) shall be provided in each nursing unit. Supply storage may be within the clean utility room used only as part of a system for distributing clean and sterile supplies.

1225.10.2.3 Wheelchairs. A room or space shall be provided in each nursing unit for wheelchairs and stretchers. The wheelchair and stretcher space shall have a minimum area of 15 square feet (1.39 m²).

1225.10.2.4 Sterile and unsterile supplies shall be stored separately.

1225.10.2.5 Location. All storage spaces shall be directly accessible on the site of the licensed facility.

1225.11 EMPLOYEE DRESSING ROOMS AND LOCKERS. Separate dressing rooms with toilet(s), lavatories and lockers for male and female personnel shall be provided.

1225.12 HOUSEKEEPING ROOMS. Housekeeping rooms shall be provided to serve each department and nursing unit, and may be shared by compatible departments, except when specifically required by other sections.

1225.13 LAUNDRY. If a laundry is to be provided, the following is required in addition to the laundry room:

1. A separate soiled linen receiving, holding and sorting room with handwashing fixture.
2. A separate clean linen storage, issuing and holding room.
3. Storage for laundry supplies.

1225.13.1 Outside service. If linen is processed off site, the following shall be provided within the hospital:

1. A soiled linen holding room.
2. A separate clean linen receiving and storage room.

OPTIONAL SERVICES

1225.14 GENERAL. Waiting areas and access to optional services for outpatients shall accommodate the following:

1225.14.1 Outpatient waiting rooms. Waiting rooms for outpatients shall provide a seating area and space for wheelchairs and have public corridor access to, or provisions for, public toilet room(s), drinking fountain and telephone.

Note: One waiting area may serve more than one department or service.

1225.14.2 Circulation. If x-ray examinations are to be performed on outpatients, outpatient access to the radiological spaces shall not traverse a nursing unit.

Exception: Satellite radiology, laboratory, pharmacy, physical and occupational therapy space serving inpatients may be located in nursing units and inpatient treatment areas.

1225.15 PHYSICAL THERAPY SERVICE.

1225.15.1 Area. The minimum floor area for a physical therapy service shall be 300 square feet (27.87 m²), with no dimensions less than 12 feet (3658 mm).

1225.15.2 Toilet room(s). Toilet room facilities shall be directly accessible and allow for patient transfer activities.

1225.15.3 Equipment space. See Title 22 for required equipment.

1225.15.4 Handwashing fixture. A minimum of one handwashing fixture shall be provided.

1225.16 OCCUPATIONAL THERAPY SERVICE. An occupational therapy service shall accommodate the requirements of Sections 1225.15.1, 1225.15.2 and 1225.15.4.

Storage space shall be provided.

Note: See Title 22 for required equipment, supplies and adaptive devices.

1225.17 SPEECH PATHOLOGY AND/OR AUDIOLOGY SERVICE. At least one space free of ambient noise shall be provided. A handwashing fixture shall be provided.

1225.18 SOCIAL WORK SERVICE. Office space for privacy in interviewing, telephoning and conferences shall be provided.

1225.19 SPECIAL TREATMENT PROGRAM SERVICE.

1225.19.1 Location. A special treatment program service providing therapeutic services to an identified mentally disordered population group shall be located in a distinct separate unit of the facility.

1225.19.2 Nursing service. The nursing service space shall comply with Section 1225.4.

1225.19.3 Activity program. The activity program space shall provide a minimum of 25 square feet (2.3 m²) of dining and recreation space per bed.

1225.19.4 Indoor and outdoor space. Shall be designated for the special treatment program.

**SECTION 1226 [OSHPD 3]
CLINICS**

1226.1 Scope. The provisions of this section shall apply to primary-care clinics, specialty clinics and psychology clinics. Primary-care clinics include free clinics, community clinics, employee clinics and optometric clinics. Specialty clinics include alternative birth centers (ABCs), surgical clinics, chronic end-stage renal dialysis clinics and rehabilitation clinics.

1226.2 Application. All new buildings and additions, alterations or repairs to existing buildings subject to licensure shall comply with applicable provisions of the California Electrical Code, California Mechanical Code, California Plumbing Code, California Fire Code, (Parts 3, 4, 5, and 9 of Title 24) and this section.

Exception: See Section 1224.2.

1226.2.1 Outpatient clinical services. Hospitals providing outpatient clinical services and clinics licensed under Health and Safety Code Section 1200 that are not covered by this section shall meet the applicable requirements in Section 1224.

1226.3 Definitions. See Section 1224.3.

1226.4 GENERAL CONSTRUCTION. Clinics shall comply with Sections 1224.4.2 through 1224.4.5 wherever applicable.

1226.5 CORRIDORS AND HALLWAYS.

1226.5.1 Connections. Corridor systems shall connect all essential services.

1226.5.2 Corridors. Rehabilitation clinics shall have corridors of at least 5 feet (1524 mm) in width, with handrails on both sides.

1226.6 DOORS AND DOOR OPENINGS.

1226.6.1 Doors. Doors for patient use shall not be less than 3 feet (914 mm) in width. Where patients are transported by wheeled stretchers, doors shall provide a minimum opening of 44 inches (1118 mm).

1226.6.2 Pocket doors. Except for administrative areas, pocket sliding doors are not permitted.

1226.7 WINDOWS AND SCREENS. Where necessary to protect against entrance of insects, screens of 16 meshes per inch shall be installed on windows which may be left in an open position.

1226.8 CEILING HEIGHTS.

1226.8.1 Minimum height. The minimum height of ceilings shall be 8 feet (2438 mm), except in closets, toilet rooms and bathrooms where the minimum ceiling height shall not be less than 7 feet (2134 mm).

1226.8.2 Minimum height with fixed ceiling equipment. Operating rooms, radiographic rooms and other rooms containing ceiling-mounted major fixed equipment or ceiling-mounted surgical light fixtures shall have ceiling heights to accommodate the equipment or fixtures and their normal movement.

1226.9 INTERIOR FINISHES—FLOORS AND BASES.

1226.9.1 Floor finishes. Shall be smooth, water resistant and durable. Upon written, appropriately documented request, the enforcing agency may grant approval of the installation of carpet.

1226.9.2 Bases. The materials and textures of bases and the installation thereof shall be so as to minimize moisture infiltration. Wood bases are prohibited except in waiting areas and administration departments.

1226.9.3 Bases/wet cleaning. Wall bases in operating rooms, cast rooms and other areas which are frequently subject to wet-cleaning methods shall be made integral and coved with the floor. Construction shall be without voids at the intersection of floor and wall surfaces.

1226.10 WALL AND CEILINGS. For wall and ceiling finish requirements, refer to Section 1224.4.11 and Table 1224.1.

1226.11 ELEVATORS.

1226.11.1 Cab requirements. Buildings over one story in height with accommodations or services for patients on floors without grade-level entrance shall provide at least one elevator in compliance with Section 3002.4.

1226.11.2 Dimensions. Elevators used for the routine transport of wheeled stretchers shall have minimum inside platform dimensions of 5 feet by 8 feet (1524 mm by 2438 mm) and a minimum clear door opening of 3 feet 8 inches (1118 mm).

1226.12 GARBAGE-SOLID WASTES AND TRASH STORAGE.

1226.12.1 Enclosure. A lockable room or screened enclosure of at least 25 square feet (2.32 m²) shall be provided for the washing and cleaning of garbage containers and for the storage of garbage, trash and other solid wastes. Such room or screened enclosure shall include the following:

1226.12.1.1 Floor and curb. A concrete floor with a curb and with a drain connected to the sewer.

1226.12.1.2 Water. Steam or hot water and cold water supplies in accordance with the California Plumbing Code.

1226.12.1.3 Size. A minimum floor area of not less than 25 square feet (2.32 m²), the least dimension of which shall be 4 feet (1219 mm). This amount of space may not be required by the enforcing agency if there is proposed a method of handling, storage, or cleaning of containers which requires a lesser amount of space. Additional space may be required by the enforcing agency when special operations or collection and disposal methods result in greater than usual accumulation of solid wastes.

1226.12.2 Compactors. Trash compactor systems shall meet the drainage and wash-down requirements under Section 1226.12.1, Items 1 and 2.

Exception: If a dumpster system is proposed, operational procedures for handling and storage must be specifically approved by the local health officials.

1226.13 LAUNDRY AND TRASH CHUTES. Gravity-type laundry and trash chutes shall conform with Section 1224.4.16.

PRIMARY CARE CLINICS

1226.14 ABORTION SERVICES. Clinics with abortion services shall provide, in addition to the basic clinic facilities:

1226.14.1 Postabortion recovery area. Shall have a minimum area of 60 square feet (5.57 m²) per recovery bed, with cubicle curtains for patient privacy.

1226.14.2 Storage. Space for the storage of patient clothing and personal items.

1226.14.3 Counseling. A room or private area of at least 60 square feet (5.57 m²) for preabortion and postabortion counseling.

1226.15 CLINICAL FACILITIES. Clinical facilities shall include the following:

1226.15.1 Examination room. Shall have a minimum area of 70 square feet (6.50 m²), the least dimension of which shall be 7 feet (2134 mm), excluding such spaces as vestibule, toilet room and work counter.

1226.15.2 Treatment room. If provided, shall have a minimum area of 120 square feet (11.15 m²), the least dimension of which shall be 10 feet (3048 mm), excluding such spaces as vestibules and work counters.

Exception: Treatment rooms used for aspiration abortion may be, as a minimum, sized as examination rooms.

1226.15.3 Handwashing fixtures. Examination and treatment rooms, including those used for abortion, shall be equipped with handwashing fixtures.

Exception: Examination and treatment rooms used for routine examinations or where surgical procedures are not performed may be equipped with fixtures having wrist or elbow controls.

1226.15.4 Records. Space shall be designed for charting and storage of clinical records.

1226.15.5 Drug distribution. A lockable drug distribution station with space for a refrigerator.

1226.15.6 Utility room. A utility room which contains storage, sinks, work counter, and separate clean and soiled

linen hampers. The room shall be designed for the separation of clean and dirty work areas. Separate clean and soiled utility rooms may be designated.

BIRTHING CLINICS

1226.16 BIRTHING CLINICS. Birthing clinics shall accommodate the provisions of Sections 1226.17.4, 1226.17.5 and 1226.17.6, as well as the following:

1. A birthing room shall provide not less than 156 square feet (14.49 m²), with a minimum dimension of 12 feet (3658 mm) of usable floor space.
2. An adjoining toilet room with a nurses' call system and a lavatory.
3. Direct access to a patient shower.
4. A handwashing fixture located within or directly outside the room. If the fixture is located within the room, the fixture may be screened or within openable casework.
5. A nurses' call system which will alert the nearest continually staffed nurses' station.
6. Lighting capable of 1076 lux (100 footcandles) at working surfaces. Dimmer switches may be used.
7. Oxygen and suction capabilities, portable or piped.
8. Space for a crash cart.
9. Space for supplies and equipment, as well as separate spaces for clean and soiled linen.

SPECIALTY CLINICS

1226.17 SURGICAL CLINICS.

1226.17.1 Operating rooms. Shall have a minimum floor dimension of 15 feet (4572 mm) and shall contain not less than 270 square feet (25.08 m²) of floor area and have provisions for the following:

1. Clock and elapsed timer.
2. X-ray film illuminator.

1226.17.2 Cast rooms, fracture rooms and cystoscopic rooms. If provided, shall have minimum floor area of 180 square feet (16.72 m²), no dimension of which shall be less than 11 feet (3353 mm).

1226.17.3 Scrub sinks. A minimum of two scrub sinks shall be provided in a surgical unit containing one operating room. Four scrub sinks shall be provided in surgical units containing two operating rooms. One additional scrub sink shall be provided for each additional operating room.

1226.17.3.1 Clock. A direct-wired or battery-operated clock or other equivalent timing device shall be visible from the scrub-up sinks.

1226.17.4 Clean-up room. Each surgical unit shall provide a clean-up room with a handwashing fixture and work space which is separate from any surgical sterilizing facilities. The clean-up room shall provide 24 square feet (2.23 m²) per operating room up to eight operating rooms, with no dimensions less than 6 feet (1829 mm). The clean-up room may be the soiled work area of the central sterile supply.

1226.17.5 Cart storage. Space for clean and soiled cart storage shall be provided if a case cart supply system is proposed.

1226.17.6 Housekeeping room. See Section 1224.4.15. The housekeeping room shall serve no other areas.

1226.17.7 Lockers. Separate dressing rooms with lockers, showers, lavatories and toilet(s) shall be provided for male and female staff.

1226.17.8 Support spaces. A surgical supervisor's station, a sterile supply storage facility stretcher space and instrument storage facilities shall be provided.

1226.17.9 Outpatient change area. A separate space shall be provided where outpatients change from street clothing and are prepared for surgery. This would include provisions for clothing storage, toilet room(s), sink space for clothing change and gowning area.

1226.17.10 Postanesthesia recovery. The postanesthesia recovery unit shall be provided and contain the following spaces:

1226.17.10.1 Size. Floor area of at least 70 square feet (6.50 m²) per bed, exclusive of the spaces listed below in Items 1226.17.10.2 and 1226.17.10.3.

1226.17.10.2 Nurses' control area. Space for a nurses' control desk, signal system annunciator, charting space, lockable medicine cabinet, refrigerator and handwashing fixture.

1226.17.10.3 Storage. Separate storage spaces of at least 10 square feet (0.93 m²) for clean and soiled linen, supplies and equipment.

1226.17.10.4 Medical air. Provisions for piped or portable oxygen and suction systems at each bed location.

1226.17.11 Central sterile supply. A central supply and sterilizing area shall be provided. Rooms and spaces to provide for the following services and equipment:

1226.17.11.1 Soiled work area. A receiving and gross cleaning area of at least 50 square feet (4.65 m²) which shall contain work space and equipment for cleaning medical and surgical equipment and for disposal of or processing unclean material.

1226.17.11.2 Clean work area. A clean work area of at least 50 square feet (4.65 m²) which shall contain space and equipment for sterilizing medical and surgical equipment and supplies.

1226.17.11.3 Separation. There shall be separation of soiled or contaminated supplies and equipment and clean work areas.

1226.17.11.4 Space for sterilizing equipment

1226.17.11.5 Supplies. Separate storage space for sterile supplies and unsterile supplies.

1226.17.11.6 Sterilizers and autoclaves. All sterilizers and autoclaves, except small instrument sterilizers which emit steam exhaust, shall be vented to the outside of the building. Such vents shall be independent from the plumbing vent system.

1226.18 CHRONIC DIALYSIS CLINICS.

1226.18.1 Size. Provide a minimum of 100 square feet (9.29 m²) of floor space, inclusive of aisles, per bed or station.

1226.18.2 Nurses' station. Shall be equipped with a cabinet, a desk, space for records, a telephone, and a specifically designated and well-illuminated medicine storage compartment with a lockable door.

1226.18.3 Utility room. Shall provide for the separation of clean and dirty work areas and shall include work counters and cabinets.

1226.18.4 Waiting area.

1226.18.5 Conference room. Provide a private room or office near or contiguous with the unit for conference space for patients and staff.

1226.18.6 Storage. Provide space for supplies and equipment.

1226.18.7 Contaminated material storage. Provide separate secure storage for all contaminated materials.

1226.18.8 Equipment room. Provide an equipment room sized to accommodate the pumps, central distribution equipment and any other necessary equipment.

1226.18.9 Toilet room(s). Provide patient toilet room(s) which are directly accessible and equipped with bedpan flushing attachment(s).

1226.18.10 Staff facilities. Provide staff lockers and change areas with toilet(s).

1226.18.11 Housekeeping room. Provide 15 square feet (1.39 m²) with service sink and storage space.

1226.18.12 Clean and soiled linen. Provide separate clean and soiled linen storage.

1226.18.13 Administration. Provide space for admitting, business and administration areas.

1226.18.14 Home training. If provided within the unit, shall contain 11.0 square feet (10.22 m²) of usable enclosed floor space.

1226.18.15 Bloodborne infection isolation room. If provided, the room shall have a minimum of 100 square feet (9.3 m²) of clear floor space.

1226.18.16 Handwashing fixtures. At least one handwashing fixture shall be provided for each of the following areas:

1. Nurses' station which may also serve up to eight patient beds or stations.
2. Bloodborne infection isolation room.
3. Home training room.
4. Utility room.
5. One additional handwashing fixture for every eight patients, or fraction thereof, not served by the nurses' station fixture.

1226.19 REHABILITATION CLINICS. Rehabilitation clinics shall meet the general requirements of Sections 1226.4 through 1226.13, as well as the following sections:

1227.13 PHARMACEUTICAL SERVICE SPACE.

1227.13.1 Licensed pharmacy. A licensed pharmacy shall be provided and shall comply with the provisions of Section 1250.

1227.13.1.1 Entrance and waiting. If the pharmacy dispenses directly to inmates from the correctional institution, an entrance and a waiting area separate from the inpatient areas shall be provided.

1227.14 DIETETIC SERVICE SPACE.

1227.14.1 Dietetic service space. The dietetic service space shall accommodate the provisions of Section 1225.5.

Exceptions:

1. The dietetic service in the correctional institution is found acceptable to the licensing agency.
2. Contractual arrangement for dietetic services with another health facility acceptable to the licensing agency.

1227.15 OFFICES. Office spaces shall be provided for the provisions of nursing, physician, psychiatric and psychological services.

1227.15.1 Consultation/interviews. Consultation/interview rooms shall be provided.

1227.15.2 Conference/group activities. Separate rooms or spaces shall be provided for conferences and group activities.

Exception: If conference room or space is available to the correctional treatment facility staff in the correctional institution, this room or space need not be duplicated.

1227.16 ADMINISTRATION SPACE.

1227.16.1 Administration. An administration area shall be provided which shall provide for the following functions:

1. Waiting area.
2. Offices for the administrator and clerical personnel.

1227.16.2 Records. Spaces shall be provided which accommodate the following functions:

1. Work area for sorting and recording records, for either paper or electronic media.
2. Secure storage area for medical records, for either paper or electronic media.

1227.17 CENTRAL STERILE SUPPLY.

1227.17.1 Minimum requirements. A central supply and sterilizing area shall be provided. Rooms and spaces shall accommodate the following services and equipment:

1. Soiled work area. A receiving and gross cleaning area which shall contain workspace and equipment for cleaning medical and surgical equipment and for disposal of or processing of soiled material.
2. Clean work area. A clean work area which shall contain work space, and equipment for sterilizing medical and surgical equipment and supplies.

3. Sterilizing space.

Exception: Items 1-3 do not apply to facilities with contractual arrangements for outside autoclaving and sterilizing services.

4. Storage. Space for sterile supplies and unsterile supplies.

1227.17.2 Sterilizers and autoclaves. All sterilizers and autoclaves which emit steam exhaust shall be vented to the outside of the building. Such vents shall be independent from the plumbing vent system.

Exception: Small instrument sterilizers.

1227.18 STORAGE.

1227.18.1 General storage. Hospitals shall provide combined general and specialized storage space in accordance with the following:

1-10 beds	120 square feet (11.15 m ²) minimum
11-100 beds	12 square feet (1.11 m ²) per bed
over 100 beds	1,200 square feet (111.48 m ²) plus 5 square feet (0.46 m ²) per bed for each bed over 100

1227.18.2 Specialized storage. Specialized storage spaces shall include the following:

1. Linen. Separate and enclosed facilities for clean and soiled linen in each nursing unit. The clean linen storage space shall have a minimum area of 10 square feet (0.93 m²) and may be within the clean utility room. The soiled linen collection space shall have an area of no less than 10 square feet (0.93 m²), and may be within the soiled utility room.
2. Supply. One supply storage space having a minimum area of 15 square feet (1.39 m²) shall be provided in each nursing unit. Supply storage may be within the clean utility room used only as part of a system for distributing clean and sterile supplies.
3. Wheelchairs. A room or space shall be provided in each nursing unit for wheelchairs and stretchers. The wheelchair and stretcher space shall have a minimum area of 15 square feet (1.39 m²).
4. Storage. Sterile and unsterile supplies shall be stored separately.

1227.19 EMPLOYEE DRESSING ROOMS AND LOCKERS.

1227.19.1 Minimum facilities. Correctional Treatment Centers shall provide the following:

1. Dressing rooms. Separate dressing rooms for male and female personnel with lockers, lavatory and toilet(s).

Exception: If provided for the Correctional Treatment Center staff in adjacent correctional institu-

tions, dressing rooms and lockers need not be duplicated.

1227.20 HOUSEKEEPING ROOM.

1227.20.1 A securely lockable housekeeping room with service sink and supply storage spaces shall be provided in each nursing unit.

OPTIONAL SERVICES

1227.21 SERVICE SPACES. Service spaces, such as laboratory, radiology and any other services approved by the licensing agency, shall comply with the applicable space requirements of Sections 1224 and 1225. Service spaces shall also comply with applicable provisions of the California Building Standards Administrative Code (Part 1).

1227.22 OUTPATIENT SERVICES. The following shall be provided or made available to a outpatient service space.

1227.22.1 Waiting. Waiting area(s) shall be provided with access to toilet room facilities and a drinking fountain both meeting the requirements of Sections 1231.3.1, 1231.3.2 and 1231.3.3.

1227.22.1.1 Holding cell. If a temporary holding cell or room is used for this purpose, it shall comply with Section 1231.2.2.

Exception: The minimum floor area shall be 80 square feet (7.43 m²).

1227.23 24-HOUR MENTAL HEALTH CARE SERVICES.

1227.23.1 Program/dining space. Provide within the Correctional Treatment Center for use by mental health treatment program patients, as is consistent with security requirements. Program/dining space shall be provided with a minimum floor area of 30 square feet (2.79 m²) per patient served at a given time.

1227.23.2 Mental health treatment. Correctional Treatment Centers providing a mental health treatment program shall include one safety room for every 30 mental health treatment program beds or fraction thereof, and one observation room providing direct observation of every portion of the room for every 15 mental health beds or fraction thereof. At least one safety room and one observation room shall be provided.

1227.23.3 Safety rooms. Safety rooms shall be constructed so as to provide video camera observation capability. Safety rooms shall comply with the design criteria requirements of Section 1231.2.5 for a safety cell.

**SECTION 1228
Reserved**

**SECTION 1229
Reserved**

**SECTION 1230 [CSA]
MINIMUM STANDARDS FOR JUVENILE FACILITIES**

1230.1 Design criteria for required spaces.

1230.1.1 Reception/intake admission. In each juvenile hall, space used for the reception of minors pending admission to juvenile hall shall have the following space and equipment:

1. Weapons lockers as specified in Section 1230.2.9;
2. A secure room for the confinement of minors pending admission to juvenile hall as specified in Section 1230.1.2;
In each juvenile hall, camp and ranch, space used for the reception of minors pending admission to these facilities shall have the following space and equipment:
3. Access to a shower;
4. A secure vault or storage space for minors, valuables;
5. Telephones accessible to minors; and
6. Access to hot and cold running water for staff use.

1230.1.2 Locked holding room. A locked holding room shall:

1. Contain a minimum of 15 square feet (1.4 m²) of floor area per minor;
2. Provide no less than 45 square feet (4.2 m²) of floor space and have a clear ceiling height of 8 feet (2438 mm) or more;
3. Contain seating to accommodate all minors as specified in Section 1230.2.8;
4. Have access to a toilet, wash basin and drinking fountain as specified in Section 1230.2; and
5. Maximize visual supervision of minors by staff.

1230.1.3 Natural light. Visual access to natural light shall be provided in locked sleeping rooms, single occupancy sleeping rooms, double occupancy sleeping rooms, dormitories and day rooms. Natural light may be provided by, but is not limited to, skylights or windows in dayrooms, windows in adjacent exterior exercise areas, and in sleeping rooms and/or dormitories.

1230.1.4 Corridors. Corridors in living units shall be at least 8 feet (2438 mm) wide.

Exception: Where room doors are staggered, or if rooms are located on only one side, hallways shall be at least 6 feet (1829 mm) wide.

1230.1.5 Living unit. A living unit shall be a self-contained unit containing locked sleeping rooms, single and double occupancy sleeping rooms, or dormitories, dayroom space, toilet, wash basins, drinking fountains and showers commensurate to the number of minors housed. A living unit shall not be divided by any permanent or temporary barrier that hinders direct access, supervision or immediate intervention or other action if needed. In juvenile halls, the number of minors housed in a living unit shall not exceed 30.

1230.1.6 Locked sleeping rooms. Locked sleeping rooms shall be equipped with an individual or combination toilet, wash basin and drinking fountain unless a procedure is in effect to give the minor access to a toilet, wash basin and drinking fountain.

1230.1.7 Single occupancy sleeping rooms. Single occupancy sleeping rooms shall provide the following:

1. A minimum of 63 square feet (5.9 m²) of floor area;
2. A minimum clear ceiling height of 8 feet (2438 mm); and,
3. The door into this room shall be provided with a view panel, a maximum of 144 square inches (92,903 mm²), constructed of security glazing.

1230.1.8 Double occupancy sleeping rooms. Double occupancy sleeping rooms shall provide the following:

1. A minimum of 100 square feet (9.3 m²) of floor area;
2. A minimum clear ceiling height of 8 feet (2438 mm) and a minimum width of 7 feet (2134 mm); and,
3. The door into this room shall be provided with a panel, a maximum of 144 square inches (92,903 mm²), constructed of security glazing.

1230.1.9 Dormitories. Dormitories shall provide the following:

1. A minimum of 50 square feet (4.6 m²) of floor area per minor with the minimum size of a dormitory being 200 square feet (18.6 m²) of floor area and a minimum 8-foot (2438 mm) clear ceiling height;
2. Designed for no fewer than four minors;
3. Dormitories for detained minors in juvenile halls shall be designed for no more than 30 minors;
4. Camps shall conform to Items 1 and 2.

>> **1230.1.10 Dayrooms.** Dayrooms shall contain 35 square feet (3.3 m²) of floor area per minor. Access must be provided to toilets, wash basins, drinking fountains and showers as specified in Section 1230.2.

1230.1.11 Physical activity and recreation areas. Indoor / outdoor physical activity and recreation areas shall be designed as follows:

1.

Facility Capacity	Minimum Indoor/Outdoor Recreation Space
40 or less	9,000 square feet (836 m ²)
41 to 274	225 square feet (21 m ²) per minor up to 61,650 square feet (5727 m ²)
	61,650 square feet (5727 m ²), plus 145 square feet (13.47 m ²) for each minor beyond 274 [up to a maximum of 87,120 square feet (8093 m ²)]
275 or more	

 - 1.1. At least one quarter of the dedicated indoor/outdoor space shall be a paved or like surface.
 - 1.2. The required recreation area shall contain no single dimension less than 40 feet (12.2 m).
2. A portion of the dedicated space for physical activity and recreation shall be out-of-doors and be of sufficient size and equipped in such a manner to allow compliance with Title 15, Section 1371, which requires at least one hour per day of outdoor activity for each detained minor.
3. Lighting of outdoor recreation areas shall be provided for evening activities and to provide security.

4. Access must be provided to a toilet, wash basin and drinking fountain as specified in Section 1230.2.

1230.1.12 Academic classrooms. There shall be dedicated classroom space for every juvenile in every facility. The primary purpose for the academic classroom shall be for education. Each academic classroom shall contain a minimum of 160 square feet (14.9 m²) of floor space for the teachers' desk and work area and a minimum of 28 square feet (2.6 m²) of floor space per minor. A communication system shall be provided in each classroom to allow for immediate response to emergencies. The classroom shall be designed for a maximum of 20 minors.

1230.1.13 Safety room. A safety room shall:

1. Contain a minimum of 63 square feet (5.9 m²) of floor area and a minimum clear ceiling height of 8 feet (2438 mm);
2. Be limited to one minor;
3. Be padded as specified in Section 1230.2.7;
4. Provide one or more vertical view panels constructed of security glazing. These view panels shall be no more than 4 inches (102 mm) wide nor less than 24 inches (610 mm) long, which shall provide a view of the entire room;
5. Provide an audio monitoring system as specified in Section 1230.1.22;
6. Provide access to a toilet, wash basin and drinking fountain outside the room as specified in Section 1230.2; and
7. Be equipped with a variable intensity, security-type lighting fixture with controls located outside the room.
8. Any wall or ceiling-mounted devices must be designed to prohibit access to the minor occupant.

1230.1.14 Medical examination room. There must be a minimum of one suitably equipped medical examination room in every juvenile facility. Medical examination rooms shall provide the following:

1. Space for carrying out routine medical examinations and emergency care and used for no other purpose;
2. Privacy for minors;
3. Lockable storage space for medical supplies;
4. Not less than 144 square feet (13.4m²) of floor space with no single dimension less than 7 feet (2134 mm);
5. Hot and cold running water; and
6. Smooth, nonporous, washable surfaces.

1230.1.15 Pharmaceutical storage. Provide lockable storage space for medical supplies and pharmaceutical preparations as specified by Title 15, Section 1438.

1230.1.16 Dining areas. Dining areas in juvenile facilities shall contain a minimum of 15 square feet (1.4 m²) of floor space and sufficient tables and seating for each person being fed. Persons being fed include minors, staff and visitors. Dining areas shall not contain toilets or showers in the same room without appropriate visual barrier.

INTERIOR ENVIRONMENT

**TABLE 1230A
REQUIRED SPACES AND EQUIPMENT IN JUVENILE FACILITIES**

SECTION NUMBER	REGULATION	HALLS	CAMPS	SPJH
1230.1.1	Reception/intake admission	X		
1230.1.2	Locked holding rooms	X	X ¹	
1230.1.3	Natural light	X	X	X
1230.1.4	Corridors	X ¹	X ¹	X ¹
1230.1.5	Living units	X		
1230.1.6	Locked sleeping rooms	X ¹	X ¹	X ¹
1230.1.7	Single occupancy sleeping rooms	X ¹	X ¹	X ¹
1230.1.8	Double occupancy sleeping rooms	X ¹	X ¹	X ¹
1230.1.9	Dormitories	X ¹	X ¹	X ¹
1230.1.10	Day rooms	X	X	X
1230.1.11	Physical activity and recreation areas	X	X	
1230.1.12	Academic classrooms	X	X	
1230.1.13	Safety rooms	X ¹		
1230.1.14	Medical examination rooms	X	X	
1230.1.15	Pharmaceutical storage	X	X	X
1230.1.16	Dining areas	X	X	
1230.1.17	Visiting space	X	X	X
1230.1.18	Institutional storage	X	X	X
1230.1.19	Personal storage	X	X	X
1230.1.20	Safety equipment storage	X	X	X
1230.1.21	Janitorial closet	X	X	X
1230.1.22	Audio monitoring system	X	X ¹	X
1230.1.23	Emergency power	X	X	X
1230.1.24	Confidential interview rooms	X	X	X
1230.1.25	Special-purpose juvenile halls	X		
1230.1.26	Court holding rooms for minors*	X ¹		
1230.2.1	Toilets/urinals	X	X	X
1230.2.2	Wash basins	X	X	X
1230.2.3	Drinking fountains	X	X	X
1230.2.4	Showers	X	X	X
1230.2.5	Beds	X	X	X
1230.2.6	Lighting	X	X	X
1230.2.7	Padding	X ¹		
1230.2.8	Seating	X	X	X
1230.2.9	Weapons lockers	X	X ¹	X

Key: Halls = Juvenile halls.

Camps = Camps, ranches, forestry camps or boot camps.

SPJH = Special-purpose juvenile halls.

* = For minors in jail, minors in temporary custody in a law enforcement facility and minors in court holding facilities, see Sections 1520, 1540 and 1560 of Title 15, respectively.

X = Regulation is applicable for all juvenile facilities.

X¹ = Regulation is applicable for halls, camps and special-purpose juvenile halls dependent on operational characteristics of the facility.

1230.1.17 Visiting space. Space shall be provided in all juvenile facilities for visiting.

1230.1.18 Institutional storage. One or more storage rooms shall be provided to accommodate a minimum of 80 cubic feet (2.3 m³) of storage space per minor. Items to be stored shall be institutional clothing, bedding, supplies and activity equipment.

1230.1.19 Personal storage. Each minor in a juvenile facility shall be provided with a minimum of 9 cubic feet (0.25 m³) of secure storage space for personal clothing and belongings.

1230.1.20 Safety equipment storage. In all juvenile facilities, a secure area shall be provided for the storage of safety equipment, such as fire extinguishers, self-contained breathing apparatus, wire and bar cutters, emergency lights, etc.

1230.1.21 Janitorial closet. In all juvenile facilities, at least one securely lockable janitorial closet, containing a mop sink and sufficient area for the storage of cleaning implements, must be provided within the security area of the facility.

1230.1.22 Audio monitoring system. In safety rooms, locked holding rooms, locked sleeping rooms, single and double occupancy rooms and dormitories, there must be an audio monitoring system capable of actuation by the minor that alerts personnel.

1230.1.23 Emergency power. There shall be a source of emergency power in all juvenile facilities capable of providing minimal lighting in all living units, activities areas, corridors, stairs, and central control points, and to maintain fire and life safety, security, communications and alarm systems. Such an emergency power source shall conform to the requirements specified in Title, 24, Part 3, Article 700, California Electrical Code, California Code of Regulations.

1230.1.24 Confidential interview room. Confidential interview rooms shall contain a minimum of 60 square feet (5.6 m²) of floor area. In juvenile halls there shall be a minimum of one suitably furnished interview room for each 30 minors. In camps there shall be a minimum of one suitably furnished interview room for each facility. This interview room shall provide for confidential consultations with minors.

1230.1.25 Special-purpose juvenile halls. Special-purpose juvenile halls and intensive supervision units located in camps and ranches shall conform to all minimum standards for juvenile facilities contained in this section with the following exceptions:

1. Physical activity and recreation areas as specified in Section 1230.1.11;
2. Academic classrooms as specified in Section 1230.1.12;
3. Medical examination room as specified in Section 1230.1.14; and,
4. Dining areas as specified in Section 1230.1.16.

If intensive supervision units are used for disciplinary purposes, the requirements of Title 15, Section 1391, Disciplinary Process shall apply.

1230.1.26 Court holding room for minors. A court holding room shall:

1. Contain a minimum of 10 square feet (0.93 m²) of floor area per minor;
2. Be limited to no more than 16 minors;
3. Provide no less than 40 square feet (3.7 m²) of floor area and have clear ceiling height of 8 feet (2438 mm) or more;
4. Contain seating to accommodate all minors as specified in Section 1230.2.8;
5. Contain a toilet, wash basin and drinking fountain as specified in Section 1230.2; and,
6. Maximize visual supervision of minors by staff.

1230.1.27 Program and activity areas. Camp and ranch facilities shall include adequate space for specific programs in addition to recreation and exercise areas.

1230.2 Design criteria for furnishings and equipment.

1230.2.1 Toilet/urinals. In living units, toilets must be available in a ratio to minors as follows:

1. Juvenile halls 1:6;
2. Camps 1:10; and
3. Locked holding rooms 1:8;

One toilet and one urinal may be substituted for every 15 males.

Note: Toilet areas shall provide privacy for the minor without mitigating staff's ability to supervise.

1230.2.2 Wash basins. In living units, wash basins must be available in a ratio to minors as follows:

1. Juvenile halls 1:6;
2. Camps 1:10; and
3. Locked holding rooms 1:8;

Wash basins must be provided with hot and cold or tempered water.

1230.2.3 Drinking fountains. In living areas and indoor and outdoor recreation areas, drinking fountains must be accessible to minors and to staff.

1. The drinking fountain bubbler shall be on an angle which prevents waste water from flowing over the drinking bubbler; and,
2. The water flow shall be actuated by a mechanical means.

1230.2.4 Showers. In living units, showers shall be available to all minors on a ratio of at least one shower or bathtub to every six minors. Showers shall be provided with tempered water.

Note: Shower areas shall provide privacy for the minor without mitigating staff's ability to supervise.

1230.2.5 Beds. Beds shall be at least 30 inches (762 mm) wide and 76 inches (1930 mm) long and be of the pan bottom type or constructed of concrete. Beds shall be at least 12 inches (305 mm) off the floor and spaced no less than 36 inches (914 mm) apart.

1230.2.6 Lighting. Lighting in locked sleeping rooms, single occupancy rooms, double occupancy rooms, dormitories, day rooms and activity areas shall provide not less than

20 footcandles (216 lux) of illumination at desk level. Night lighting is required in these areas to provide good visibility for supervision and be conducive to sleep.

1230.2.7 Padding. In safety rooms, padding shall cover the entire floor, door, walls and everything on the walls to a clear height of 8 feet (2438 mm). Benches or platforms are not to be placed on the floor of this room.

All padded rooms must be equipped with a tamper-resistant fire sprinkler as approved by the State Fire Marshal. All padding must be:

1. Approved for use by the State Fire Marshal;
2. Nonporous to facilitate cleaning;
3. At least 1/2 inch (12.7 mm) thick;
4. Of a unitary or laminated construction to prevent its destruction by teeth, hand tearing or small metal objects;
5. Firmly bonded to all padded surfaces to prevent tearing or ripping; and,
6. Without any exposed seams susceptible to tearing or ripping.

1230.2.8 Seating. Seating shall be designed to the level of security. When bench seating is used, 18 inches (457 mm) of bench is seating for one person.

1230.2.9 Weapons lockers. Weapons lockers are required in all secure juvenile facilities and shall be located outside the security perimeter of the facility. Personnel shall not bring any weapon into the security area. Weapons lockers shall be equipped with individual compartments, each with an individual locking device.

1230.2.10 Security glazing. Security glazing shall comply with the minimum requirements of one of the following test standards: American Society for Testing and Materials, ASTM F 1233-98, Class III glass, or ; California Department of Corrections, CDC 860-94d, Class C glass or; H.P. White Laboratory, Inc., HPW-TP-0500.02, Forced Entry Level III.

SECTION 1231 [CSA] LOCAL DETENTION

1231.1 Definitions.

CORRECTIONS STANDARDS AUTHORITY means the State Corrections Standards Authority, which acts by and through its executive officer, deputy directors and field representatives.

LIVING AREAS means those areas of a facility utilized for the day-to-day housing and activities of inmates. These areas do not include special-use cells such as sobering, safety and holding or staging cells normally located in receiving areas.

LOCAL DETENTION FACILITY is any city, county, city and county, or regional jail, camp, court holding facility or other correctional facility, whether publicly or privately operated, and court holding facility used for the confinement of adults or of both adults and minors, but does not include that portion of a facility for the confinement of both adults and minors which is

devoted only to the confinement of minors. The types of local detention facilities are as follows:

Court holding facility means a local detention facility constructed within a court building after January 1, 1978, used for the confinement of persons solely for the purpose of a court appearance for a period not to exceed 12 hours.

Temporary holding facility means a local detention facility constructed after January 1, 1978, used for the confinement of persons for 24 hours or less pending release, transfer to another facility or appearance in court.

Type I facility means a local detention facility used for the detention of persons usually pending arraignment for not more than 96 hours, excluding holidays, after booking. Such a Type I facility may also detain persons on court order either for their own safe-keeping or sentenced to a city jail as an inmate worker, and may house inmate workers sentenced to the county jail provided such placement in the facility is made on a voluntary basis on the part of the inmate. As used in this section, an inmate worker is defined as a person assigned to perform designated tasks outside of his or her cell or dormitory, pursuant to the written policy of the facility, for a minimum of four hours each day on a five-day scheduled work week.

TYPE II FACILITY means a local detention facility used for the detention of persons pending arraignment, after arraignment, during trial and upon a sentence of commitment.

TYPE III FACILITY means a local detention facility used only for the detention of convicted and sentenced persons.

TYPE IV FACILITY means a local detention facility or portion thereof designated for the housing of inmates eligible, under Penal Code Section 1208, for work/education furlough and/or other programs involving inmate access into the community.

RATED CAPACITY means the number of inmate occupants for which a facility's single-and double-occupancy cells or dormitories, except those dedicated for medical or disciplinary isolation housing, were planned and designed in conformity to the standards and requirements contained herein and in Title 15, C.C.R.

1231.2 Design criteria for required spaces.

1231.2.1 Reception and booking. Facilities where booking and housing occur shall have the following space and equipment:

1. Weapons locker as specified in Section 1231.3.12.
2. A cell or room for the confinement of inmates pending their booking, complying with Section 1231.2.2.
3. A sobering cell as described in Section 1231.2.4 if intoxicated, inmates who may pose a danger to themselves or others are held. For those facilities that accept male and female intoxicated inmates two sobering cells shall be provided.
4. Access to a shower within the secure portion of the facility.
5. Provide access to a secure vault or storage space for inmate valuables.

FIREPLACES, FACTORY-BUILT	2111.13.1	FLOOR LOADS	
FIREPLACES, MASONRY	2102.1	Construction documents	1603.1.1
Combustibles	2111.11	Live	1607.3, 1607.4
General provisions	2111	Posting	1603.3
Hearth extension	2111.9, 2111.10	FLOORS AND LEVELS	1120B
Steel units	2111.5.1	FLOOR OPENING PROTECTION	
FIREWORKS	307.3	(see VERTICAL OPENING PROTECTION)	
FIXED GUIDEWAY TRANSIST		FOAM PLASTICS	402.15.5
SYSTEMS	303.2, 433	Attics	719.3.1, 2603.4.1.6
<i>Fire alarm and communication systems</i>	907.2.26	Cold storage	2603.4.1.2
FIXED OR BUILT-IN SEATING, TABLES,		Concealed	603
AND COUNTERS	1122B	Crawl space	2603.4.1.6
FLAMESPREAD	802, Table 803.5	Density mall signs	402.15.5.1
FLAMMABLE AND		Doors	2603.4.1.7
COMBUSTIBLE LIQUIDS	415.6.2	Exterior walls of multistory buildings	2603.5
FLAMMABLE FINISHES	416	Interior finish	801.2.2, 2603.9, 2604
Fire protection	416.4	Label/identification	2603.2
FLAMMABLE SOLIDS	307.5, 415.1	Roofing	2603.4.1.5
FLASHING	1503.2, 1507.3.9, 1507.5.6,	Siding backer board	2603.4.1.10
1507.7.6, 1507.8.7, 1507.9.8, 1510.6		Stages and platform scenery	410.3.6
Roof	1503.2	Surface burning characteristics	2603.3
Wall, veneer	1405.3, 1405.11.7	Thermal barrier requirements	2303.4, 2603.5.2
FLOOD-RESISTANT CONSTRUCTION		Thickness	402.15.5.2
Elevation certificate	109.3.3	Trim	806.3, 2604
Existing	3403.1, 3407.2, 3410.2.4.1	Walk-in coolers	2603.4.1.3
Flood loads	1602.1, 1603.1, 1612, 3001.2, 3102.7	FOLDING AND TELESCOPIC SEATING	1025.1.1
Flood resistance	1403.5, 1403.6	<i>Accessibility</i>	1104B.3, 1104B.4
Flood resistant construction	Appendix G	<i>Egress</i>	1025.1.1
Grading and fill	1803.4, 1807.1.2.1	<i>Footboards</i>	1025.1.1
Interior finishes	801.1.3	<i>Occupant load</i>	1004.7
Site plan	106.2	FOOD COURT	402.2
Ventilation, under floor	1203.3.2	Occupant load	402.4.1.4
FLOOR/CEILING (see FLOOR CONSTRUCTION)		FOOTBOARDS	402.4.1.4, 1025.1.1
FLOOR CONSTRUCTION (see FLOOR		FOOTINGS AND FOUNDATIONS	1805
CONSTRUCTION, WOOD)		FORMWORK, CONCRETE	1906
Draft stopping	717.3	FOUNDATION	
Fire resistance	711	Basement wall loads	1610
Live loads	1607.3, 1607.4	Footing design	1801.2, 1805.4.1
Materials	Chapter 6	Pier	1808, 1812
Penetration of fire-resistant assemblies	711.5, 712	Pile (see PILE FOUNDATIONS)	1808, 1809,
FLOOR CONSTRUCTION, WOOD		1810, 1811	
Beams and girders	2304.11.2.4, 2308.7	Required for wood buildings	2308.6
Bridging/blocking	2308.8.5, 2308.10.6	Rodentproofing	Appendix F
Diaphragms	2305.2	Soils investigation (see SOILS AND	
Fastening schedule	2304.9.1	FOUNDATIONS)	1802.2, 1802.4
Framing	602.4.2, 2304.4	Special inspections	1704.4, 1704.8, 1704.9
Joists	2308.8	Waterproofing and dampproofing	1807
Sheathing	2304.7	FOYERS	
FLOOR COVERING	804.1, 804.2	Assembly occupancy	1025.4
FLOOR FINISH, INTERIOR	804	Covered mall	402.1
FLOOR LEVEL AT DOORS	1008.1.4		

FRATERNITIES 310
FREE-STANDING PEDESTAL 202, 1101C.1
FROST PROTECTION 1805.2.1
FULL-TIME CARE (definition) 310.2
FURNACE ROOMS 1015.3

G

GALLERIES

Means of egress 410.3.2, 1015.6.1, 1025.5
 Sprinklers 410.6

GARAGE, AUTOMOBILE PARKING 406.2

Accessible provisions . . . *Chapter 11A, 1129B, 1130B*
 Barriers, vehicle 406.2.4, 1607.7.3
 Beneath other occupancies 406.2.7, 509
 Construction type 406.3.3, Table 503, Table 601
 Enclosed 406.4
 Guards 406.2.3
 Live load Table 1607.1
 Occupancy separation 508.3.3, 509
 Occupant load Table 1004.1.2
 Open 406.3
 Sprinklers 903.2.9
 Underground 405

GARAGE, REPAIR 406.6

Floor surface 406.6.4
 Gas-detection system 406.6.6, 908.5
 Sprinklers 903.2.8.1
 Ventilation 406.6.3

GARAGES, TRUCK AND BUS

Live load 1607.6
 Sprinklers 903.2.9.1

GARAGES AND CARPORTS, PRIVATE . 406.1, 508.2

Area limitations 406.1.2

GATES 1008.2

GENERAL CODE PROVISIONS *CA Chapter 1*

GIFT SHOPS 407.2.4

GIRDERS

Fire resistance Table 601
 Materials Chapter 6
 Wood construction 2304.11.2.4, 2308.7

GLASS (see GLAZING)

GLASS BLOCK (see GLASS UNIT MASONRY)

GLAZING

Athletic facilities 2408
 Doors . . 704.12.1, 709.5, 715.4.3.2, 1405.12, 1714.5
 Fire doors 715.4.4.1, 715.4.6
 Fire resistant walls 715.4.3.2
 Fire windows 714.5, 715.5
 Handrails and guards 1013.1, 2406.3, 2407
 Identification 2403.1, 2406.2

Impact loads 2406.1, 2408.2.1
 Impact resistance 1609.1.2
 Jalousies 2403.5
 Label/identification 715.4.5.1, 715.4.6.3, 715.5.8
 Loads 2404
 Louvered windows 2403.5
 Nonwired 715.4.4
 Opening protectives 715.2
 Railings 2407
 Replacement 2401.2, 3405
 Safety 715.4.6.4, 2406
 Skylights 2405
 Sloped 2404.2, 2405
 Swimming pools 2406.3
 Supports 2403.2
 Testing 1714.5, 2406.1.1, 2408.2.1
 Veneer 1405.11
 Vertical 2404.1
 Wired 715.5.3

GLASS UNIT MASONRY 2102.1, 2110

Atrium enclosure 404.5
 Design method 2101.2.5
 Fire resistance 2110.1.1
 Hazardous locations 2406.1.3, 2406.3.1
 Material requirements 2103.6
 Placing 2104.1.2.4

GRAB BAR 1127A.2, 1115B.7

Definition 202, 1107A.7-G

GRADE (adjacent ground elevation) (definition) . 202

GRADE (PLANE) 502

GRADE, LUMBER (see LUMBER) 2302.1

GRAIN ELEVATORS 415.6.1.5

GRANDSTANDS 303.1, 1025.1.1

Accessibility 1104B.4

Exit signs 1011

Live load Table 1607.1

Occupant load 1004.7

GREENHOUSES

Area Table 503

Classification of 312.1

Deflections Table 1604.3

Membranes 3102.1

Plastic 2606.11

Roof live load 1607.11.2.1

Sloped glazing 2405

GRIDIRON

Means of egress 410.3.2, 1015.6.1

Sprinklers 410.6

GRINDING ROOMS 415.6.1.2

HISTORY NOTE APPENDIX

CALIFORNIA BUILDING CODE

Title 24, Part 2, California Code of Regulations (CCR)

For prior history, see the History Note Appendix to the California Building Code, 2001 Triennial Edition effective November 1, 2002.

1. (BSC 01/06, BSC 06/06, DSA-AC 01/06, DSA-AC 02/06, DSA-SS 01/06, DSA-SS 02/06, HCD 04/06, OSHPD 02/06, OSHPD 03/06, OSHPD 04/06, SFM 05/06) Adoption by reference of the 2006 *International Building Code* with necessary state amendments and repeal of the 1997 edition of the *Uniform Building Code*. Filed with the Secretary of State on February 15, 2007 and effective on January 1, 2008.
2. (SFM EF 02/07) Amend Chapter 7A, Section 701A.3.2 to clarify the dates established for State Responsibility Areas as January 1, 2008 and Local Agency Very-High Fire Hazard Severity Zones as July 1, 2008 filed with Secretary of State on September 27, 2007, effective January 1, 2008.
3. Erratum to correct editorial errors in Chapter 1, Section 108.2.1.3. Chapter 1, Section 109.1.2.1. Chapter 2, Definitions - Matrix Adoption Table correction. Chapter 4, Section 430 - Article reference change. Chapter 5, Table 503. Chapter 5, Section 507.3. Chapter 11A, Section 1110A.2. Chapter 11A, Figure 11A-9D and 11A-9E out of order. Chapter 11A, Section 1121B.3.1 (8) (a), Chapter 11A, Section 1124A.3.2.1. Chapter 11A, Section 1143A.4. Chapter 11B, Section 1111B, 1115B.3, 1129B.4, 1133B.4.5.3, 1133B.7.1.3 and Figure 11B-11. Chapter 12, Matrix Adoption Table. Chapter 12, Section 1250.1 and 1250.4. Chapter 15, Section 1511.1. Chapter 16A, Section 1614A.1.13. Chapter 17A, Section 1714A.5.2. Chapter 18, Matrix Adoption Tables. Chapter 29, Fixture Table 2902.1. Chapter 31, Section 3109.4.4.2 through 3109.4.4.8. Chapter 31A - Clarify reference to Title 8 for provisions. Chapter 35, NFPA 13-02. Appendix Chapter 1, Section 101.4.2, 101.4.5, 102.6 and 103.3.
4. (OSHPD EF 01/07) Amend Chapters 16A, 17A, 18A, 22A, 34 and 34 A to incorporate the ASCE 41-06, Seismic Rehabilitation of Existing Buildings as a referenced standard. Repeal FEMA 356, relocate necessary amendments of FEMA 356 into the ASCE 41-06. Amend by adopting the PTI-2004-4th edition. Incorporation of an advisory issued by AISG to require Steel Concentric Braced Frame (SCBF) based on Hollow Structural Steel Sections (HSS).
5. (SFM EF 01-08) Amend Title 24, Part 2, Chapters 2, 4, 7, 9 and 27. Approved as an emergency by the California Building Standards Commission on May 21, 2008. Filed with the Secretary of State on May 23, 2008.
6. (DSA-AC EF 01-08) Amend Title 24, Part 2, Chapter 11B, Figure 11B-18A, 11B-18-B and 11B-18C, Accessible Parking Stalls. Approved as an emergency by the California Building Standards Commission on May 21, 2008. Filed with the Secretary of State on June 4, 2008, effective July 1, 2008.
7. (SFM 01-08, 02-08, 03-08, 04-08) Changes without regulatory effect to Sections 310, 445, 704, 903 and 1011. Filed with the Secretary of State on July 14, 2008.
8. (BSC P 01/08, HCD 02/07, OSHPD 02/07, OSHPD 03/07, SFM 01/07, DSA/AC 01/07, DSA/AC EF 01/08) Amended California Building Code Vol. 1 & 2, California Chapter 1, Chapters 2, 3, 4, 5, 6, 7, 7A, 8, 9, 10, 11A, 11B, 11C, 12, 16, 16A, 17, 19A, 21A, 23, 27, 30, 31A, 34, 35, and Appendix Ch. 1, filed with the Secretary of State on September 12, 2008 and effective August 1, 2009. Errata changes to Index for CBC, California Chapter 1, Chapters 3, 4, 7, 9, 10, 16A, 17, 31A, and 34.
9. (CSA 01/06) Amend Chapter 12 (formerly known as Chapter 4A, Section 460A) to add new language to Sections 1230.1.1, 1230.1.5 and 1230.1.10. Approved by the California Building Standards Commission on July 17, 2008. Filed with the Secretary of State on October 21, 2008 and effective 180 days after publication.
10. (SFM EF 01-08) Amend Title 24, Part 2, Chapters 2, 4, 7, 9 and 27. Re-approved as an emergency by the California Building Standards Commission on September 11, 2008. Approved as permanent by the California Building Standards Commission on October 27, 2008. Filed with the Secretary of State on November 3, 2008.

