

127-96

Factory-Built Fireplaces
— with Revisions through November 2006

Underwriters Laboratories Inc. (UL)
333 Pfingsten Road
Northbrook, IL 60062-2096

UL Standard for Safety for Factory-Built Fireplaces, UL 127

Seventh Edition, Dated May 16, 1996

Revisions: This Standard contains revisions through and including November 10, 2006.

Summary of Topics

This revision to ANSI/UL 127 includes reaffirmation as an American National Standard.

Text that has been changed in any manner is marked with a vertical line in the margin. Changes in requirements are marked with a vertical line in the margin and are followed by an effective date note indicating the date of publication or the date on which the changed requirement becomes effective.

The requirements are substantially in accordance with UL's Proposal(s) on this subject dated August 11, 2006.

The revisions dated November 10, 2006 include a reprinted title page (page1) for this Standard.

The revisions dated January 26, 1998 were issued to correct typographical errors and to change references to UL 547, Standard for Thermal Protectors for Motors, to UL 2111, Standard for Overheating Protection for Motors . UL 547 has been withdrawn and replaced by UL 2111.

As indicated on the title page (page 1), this UL Standard for Safety is an American National Standard. Attention is directed to the note on the title page of this Standard outlining the procedures to be followed to retain the approved text of this ANSI/UL Standard.

The UL Foreword is no longer located within the UL Standard. For information concerning the use and application of the requirements contained in this Standard, the current version of the UL Foreword is located on ULStandardsInfoNet at: <http://ulstandardsinfonet.ul.com/ulforeword.html>

The master for this Standard at UL's Northbrook Office is the official document insofar as it relates to a UL service and the compliance of a product with respect to the requirements for that product and service, or if there are questions regarding the accuracy of this Standard.

UL's Standards for Safety are copyrighted by UL. Neither a printed copy of a Standard, nor the distribution diskette for a Standard-on-Diskette and the file for the Standard on the distribution diskette should be altered in any way. All of UL's Standards and all copyrights, ownerships, and rights regarding those Standards shall remain the sole and exclusive property of UL.

All rights reserved. No part of this publication may be reproduced, stored in a retrieval system, or transmitted in any form by any means, electronic, mechanical photocopying, recording, or otherwise without prior permission of UL.

Revisions of UL Standards for Safety are issued from time to time. A UL Standard for Safety is current only if it incorporates the most recently adopted revisions.

UL provides this Standard "as is" without warranty of any kind, either expressed or implied, including but not limited to, the implied warranties of merchantability or fitness for any purpose.

UL Copyright Material

Not Authorized for Further Reproduction or Distribution without Permission from UL

In no event will UL be liable for any special, incidental, consequential, indirect or similar damages, including loss of profits, lost savings, loss of data, or any other damages arising out of the use of or the inability to use this Standard, even if UL or an authorized UL representative has been advised of the possibility of such damage. In no event shall UL's liability for any damage ever exceed the price paid for this Standard, regardless of the form of the claim.

UL will attempt to answer support requests concerning electronic versions of its Standards. However, this support service is offered on a reasonable efforts basis only, and UL may not be able to resolve every support request. UL supports the electronic versions of its Standards only if they are used under the conditions and operating systems for which it is intended. UL's support policies may change from time-to-time without notification.

UL reserves the right to change the format, presentation, file types and formats, delivery methods and formats, and the like of both its printed and electronic Standards without prior notice.

Purchasers of the electronic versions of UL's Standards for Safety agree to defend, indemnify, and hold UL harmless from and against any loss, expense, liability, damage, claim, or judgement (including reasonable attorney's fees) resulting from any error or deviation introduced while purchaser is storing an electronic Standard on the purchaser's computer system.

If a single-user version electronic Standard was purchased, one copy of this Standard may be stored on the hard disk of a single personal computer, or on a single LAN file-server or the permanent storage device of a multiple-user computer in such a manner that this Standard may only be accessed by one user at a time and for which there is no possibility of multiple concurrent access.

If a multiple-user version electronic Standard was purchased, one copy of the Standard may be stored on a single LAN file-server, or on the permanent storage device of a multiple-user computer, or on an Intranet server. The number of concurrent users shall not exceed the number of users authorized.

Electronic Standards are intended for on-line use, such as for viewing the requirements of a Standard, conducting a word search, and the like. Only one copy of the Standard may be printed from each single-user version of an electronic Standard. Only one copy of the Standard may be printed for each authorized user of a multiple-user version of an electronic Standard. Because of differences in the computer/software/printer setup used by UL and those of electronic Standards purchasers, the printed copy obtained by a purchaser may not look exactly like the on-line screen view or the printed Standard.

An employee of an organization purchasing a UL Standard can make a copy of the page or pages being viewed for their own fair and/or practical internal use.

The requirements in this Standard are now in effect, except for those paragraphs, sections, tables, figures, and/or other elements of the Standard having future effective dates as indicated in the note following the affected item. The prior text for requirements that have been revised and that have a future effective date are located after the Standard, and are preceded by a "SUPERSEDED REQUIREMENTS" notice.

New product submittals made prior to a specified future effective date will be judged under all of the requirements in this Standard including those requirements with a specified future effective date, unless the applicant specifically requests that the product be judged under the current requirements. However, if the applicant elects this option, it should be noted that compliance with all the requirements in this Standard will be required as a condition of continued Listing, Classification and Follow-Up Services after the effective date, and understanding of this should be signified in writing.

Copyright © 2006 Underwriters Laboratories Inc.

This Standard consists of pages dated as shown in the following checklist:

Page	Date
1-2A	November 10, 2006
2B-3	November 9, 1999
4	November 10, 2006
5-6B	November 9, 1999
7	May 16, 1996
8	January 13, 1999
8A-8B	January 26, 1998
9-10	May 16, 1996
11-14	January 13, 1999
14A-14B	January 26, 1998
15	May 16, 1996
16-18B	January 13, 1999
19-20	May 16, 1996
21	August 25, 1997
22-22B	January 26, 1998
23	August 25, 1997
24-26	May 16, 1996
27	January 26, 1998
28	August 25, 1997
28A-28B	January 26, 1998
29	May 16, 1996
30-32	January 13, 1999
33-35	May 16, 1996
36-38	January 26, 1998
39-48	May 16, 1996
49-52	January 26, 1998
53-54	January 13, 1999
55-56B	January 26, 1998
57	May 16, 1996
58-59	January 26, 1998
60-65	May 16, 1996
66-67	January 26, 1998
68-69	May 16, 1996
70-70B	January 26, 1998
71-74D	November 9, 1999
75-84	May 16, 1996
85-86B	January 13, 1999
87-88A	January 26, 1998
88B	February 24, 1997
89-90B	January 13, 1999
91-93	May 16, 1996
94-97	January 26, 1998
98	May 16, 1996
99	November 9, 1999
100	May 16, 1996
101-102	January 13, 1999
102A	November 9, 1999
102B-103	January 13, 1999
104-104B	January 26, 1998

105-106 May 16, 1996
107-109 January 13, 1999
110 May 16, 1996
111 August 25, 1997
112 May 16, 1996
A1-A2 January 13, 1999
SR1 November 9, 1999
SR2-SR2B January 13, 1999
SR3-SR4 June 15, 1998

MAY 16, 1996
(Title Page Reprinted: November 10, 2006)



ANSI/UL 127-2006

1

UL 127

Standard for Factory-Built Fireplaces

First Edition – October, 1958
Second Edition – January, 1960
Third Edition – July, 1970
Fourth Edition – September, 1971
Fifth Edition – November, 1981
Sixth Edition – September, 1988

Seventh Edition

May 16, 1996

The most recent designation of ANSI/UL 127 as a Reaffirmed American National Standard (ANS) occurred on November 1, 2006.

This ANSI/UL Standard for Safety, which consists of the Seventh edition with revisions through November 10, 2006, is under continuous maintenance, whereby each revision is ANSI approved upon publication.

An effective date included as a note immediately following certain requirements is one established by Underwriters Laboratories Inc.

Revisions of this Standard will be made by issuing revised or additional pages bearing their date of issue. A UL Standard is current only if it incorporates the most recently adopted revisions, all of which are itemized on the transmittal notice that accompanies the latest set of revised requirements. Comments or proposals for revisions on any part of the Standard may be submitted to UL at any time. Proposals should be submitted via a Proposal Request in UL's On-Line Collaborative Standards Development System (CSDS) at <http://csds.ul.com>.

ISBN 1-55989-980-8

COPYRIGHT © 2006 UNDERWRITERS LABORATORIES INC.

No Text on This Page

CONTENTS

INTRODUCTION

1 Scope	5
2 Glossary	5
3 Components	6
4 Units of Measurement	6
5 Terms	6

CONSTRUCTION

6 Materials	6A
6.1 General	6A
6.2 Air duct system	9
7 Assembly	10
7.1 General	10
7.2 Joints	10
7.3 Firestop spacers	11
7.4 Support assembly	11
7.5 Radiation shield	11
7.6 Flue damper	12
7.7 Chimney caps	12
7.8 Roof assemblies	13
7.9 Firescreens	13
7.10 Chimney elbows	13
7.11 Gas pipe provision	14
7.12 Air duct system	14
7.13 Handles	14A
7.14 Integral grates	14A
7.15 Openings in chimney walls	14A

PERFORMANCE

8 General	15
9 Test Installations	16
10 Temperature Measurement	28A
11 Preconditioning Tests	43
11.1 General	43
11.2 Thermal shock test	43
11.3 Temperature test – 1700°F flue gases	46
11.4 Temperature test – 2100°F flue gases	47
12 Radiant Fire Test	49
13 Brand Fire Test	51
14 Flash Fire Test	55
14A Optional Unvented Decorative Log Temperature Test	55
15 Support Test	56
16 Fire Chamber Strength Test	56
17 Chimney Strength Test	60
17.1 General	60

17.2	Impact test	60
17.3	Longitudinal force test	62
17.4	Load test for chimney elbows	62
17.5	Chimney joint load test	62
17.6	Chimney joint torsion test	64
18	Wind Load Test	64
19	Rain Test	65
20	Crushing Test of Nonmetallic Flue-Gas Conduit or Insulation	68
21	Resistance to Action of Acids Test of Nonmetallic Flue-Gas Conduit	69
22	Freezing and Thawing Test of Water-Absorptive Nonmetallic Materials	69
23	Cemented Joint Test of Flue-Gas Conduit	69
24	Sulfuric Acid Extraction Test for Porcelain-Coated Steel Used for Flue-Gas Conduit	70A
25	Glazing Test	71
25.1	General	71
25.2	Impact test	71
25.3	Water shock test	71

OUTDOOR FIREPLACES

25A	General	72
25B	Construction	72
25C	Performance	72
25C.1	General	72
25C.2	Hot and cold conditioning test	73
25C.3	Freezing and thawing tests for refractory materials	73
25C.4	Wind test	74
25D	Marking	74A
25E	Operating instructions	74A

FIREPLACES FOR USE IN MANUFACTURED HOMES

26	General	74A
26.1	Installation	74A
26.2	Chimney	74B
26.3	Spark arrester	74B
26.4	Combustion air inlet	74B
26.5	Test structure	74B
26.6	Test method	74B
26.7	Drop test	75

BLOWER ASSEMBLY

GENERAL

27	General	75
----	---------	----

CONSTRUCTION

28	Enclosure	76
28.1	General	76
28.2	Mechanical protection	79
28.3	Electrical protection	80
28.4	Doors and covers	82

29	Mounting of Electrical Components	83
30	Field-Installed Blower Assemblies	84
31	Field Supply Connections	85
32	Grounding	87
33	Internal Wiring	88
	33.1 General	88
	33.2 Methods	88A
34	Separation of Circuits	90
35	Bonding for Grounding	90A
36	Capacitors	92
37	Insulating Material	93
38	Motors and Motor Overcurrent (Overload) Protection	93
39	Switches and Controllers	96
40	Transformers	96
41	Spacings	96

PERFORMANCE

42	Test Voltages	99
43	Temperature Measurements	99
	43.1 Thermocouple method	99
	43.2 Change-in-resistance method	100
44	Input Test	100
45	Temperature Test – Electrical Components	100
46	Dielectric Voltage Withstand Test	101
47	Stalled Motor Test	101
48	Strain Relief Test	101
48A	Push-Back Relief Test	101
49	Short-Circuit Test	102
50	Knockout Test	102

MANUFACTURING AND PRODUCTION TESTS

51	Production Line Dielectric Voltage-Withstand Test	102A
----	---	------

MARKING

52	General	102A
----	---------------	------

MARKING PERMANENCY

53	Marking Permanency Tests	106
	53.1 General	106
	53.2 Air oven-aging test	106
	53.3 Humidity test	106
	53.4 Unusual-condition exposure test	106

INSTALLATION INSTRUCTIONS

54	Installation and Operating Instructions	106
	54.1 General	106
	54.2 Installation instructions	107
	54.3 Operating instructions	108B

Standards for Components..... A1

No Text on This Page

This page intentionally left blank.

INTRODUCTION

1 Scope

1.1 These requirements cover factory-built fireplaces, including the fire chamber, chimney, roof assembly, and other related parts that are entirely factory-made and that are intended for unit assembly in the field.

1.2 These requirements cover factory-built fireplaces having a fire chamber intended to be operated either open to a room or, when equipped with doors, operated with the doors either open or closed.

1.3 These requirements cover factory-built fireplaces intended for use with either solid wood or coal fuels.

1.4 The factory-built fireplaces covered by these requirements are intended for installation in accordance with the National Fire Protection Association Standard for Chimneys, Fireplaces, Vents and Solid-Fuel Burning Appliances, NFPA 211, and in accordance with codes such as the BOCA Basic/National Code, the Standard Mechanical Code, and the Uniform Building Code.

1.5 As covered by these requirements, an air duct system portion of a circulating warm air type fireplace is intended for installation in accordance with the National Fire Protection Association Standard for Warm Air Heating and Air Conditioning Systems, NFPA 90B.

1.6 These requirements also cover fixed blowers, and other electrical accessories for factory-built fireplaces, rated at 600 volts or less, and intended to be employed in specified locations in accordance with the National Electrical Code, NFPA 70.

1.7 The chimneys for factory-built fireplaces covered by these requirements comply with either a 1700°F (927°C) flue-gas temperature test or a 2100°F (1149°C) flue-gas temperature test, at the manufacturer's option.

1.8 A product that contains features, characteristics, components, materials, or systems new or different from those covered by the requirements in this Standard, and that involves a risk of fire, electric shock, or injury to persons shall be evaluated using the appropriate additional component and end-product requirements to determine that the level of safety as originally anticipated by the intent of this Standard is maintained. A product whose features, characteristics, components, materials, or systems conflict with specific requirements or provisions of this Standard shall not be judged to comply with this Standard. Where appropriate, revision of requirements shall be proposed and adopted in conformance with the methods employed for development, revision, and implementation of this Standard.

1.8 revised November 9, 1999

2 Glossary

2.1 For the purpose of this standard, the following definitions apply.

2.2 CIRCULATING WARM AIR-DUCTED TYPE FIREPLACE – A fireplace having a convection type air duct system attached to the fire chamber so that heated air is directed to areas or locations other than directly in front of or above the fire chamber opening.

2.3 COMBUSTIBLE MATERIAL, NONCOMBUSTIBLE MATERIAL – As used in these requirements, these terms are defined in the Standard Glossary of Terms Relating to Chimneys, Vents, and Heat-Producing Appliances, NFPA No. 97M-1992.

2.4 CONVECTION SYSTEM – An air heating system through which air is circulated by convection. It relies upon an integral fan or blower.

2.5 HEARTH – The floor area within the fire chamber of a fireplace upon which the fire is built.

2.6 HEARTH EXTENSION – The noncombustible surfacing applied to the exposed combustible floor area external to the hearth, as specified in the installation instructions.

3 Components

3.1 Except as indicated in 3.2, a component of a product covered by this standard shall comply with the requirements for that component. See Appendix A for a list of standards covering components generally used in the products covered by this standard.

3.2 A component need not comply with a specific requirement that:

- a) Involves a feature or characteristic not needed in the application of the component in the product covered by this standard, or
- b) Is superseded by a requirement in this standard.

3.3 A component shall be used in accordance with its recognized rating established for the intended conditions of use.

3.4 Specific components are recognized as being incomplete in construction features or restricted in performance capabilities. Such components are intended for use only under limited conditions, such as certain temperatures not exceeding specified limits, and shall be used only under those specific conditions for which they have been recognized.

4 Units of Measurement

4.1 If a value for measurement is followed by a value in other units in parentheses, the first stated value is the requirement.

5 Terms

5.1 As used in these requirements, the term "fireplace" refers to all factory-built fireplaces or any part thereof covered by these requirements, unless specifically noted otherwise.

CONSTRUCTION

6 Materials

6.1 General

6.1.1 A fire chamber or chimney part shall be made of noncombustible corrosion-resistant materials. Metals shall not be used in combinations that may cause galvanic action at any location within the assembly.

6.1.2 The minimum thickness of sheet metal, including any coatings, shall comply with Table 6.1 unless otherwise specified in these requirements.

Exception: Decorative metal parts are not required to comply with Table 6.1.

No Text on This Page

Table 6.1
Minimum metal thickness

	Inch	mm
Aluminum alloys	0.016	0.41
Steel (uncoated or painted)	0.042	1.07
Galvanized steel (G-90 coating class)	0.018	0.46
Galvanized steel (G-60 coating class)	0.025	0.64
Aluminum-coated steel Type T1-40 (regular)[0.40 ounce per square foot (0.12 kg/m ²)]	0.018	0.46
Stainless steel	0.012	0.30

6.1.3 Aluminum alloys containing more than 1.0 percent magnesium shall not be used when the reflectivity of the material is employed to reduce the risk of fire.

6.1.4 A flue-gas-conveying conduit of a chimney shall be of a material equivalent to that of a material specified in Table 6.2. Cast refractory, clay tile, and porcelain-coated steel shall comply with the requirements of the applicable tests described in Sections 20 – 24.

Table 6.2
Minimum thickness of flue-gas conduit material

Equivalent nominal inside diameter of chimney		Cast refractory or clay tile		Porcelain-coated steel-base metal		Series 300 and types 430 and 446 stainless steel	
Inches	mm	Inch	mm	Inch	mm	Inch	mm
12 or less	305 or less	0.40	10.2	0.026	0.66	0.012 ^a	0.30
Over 12 – 24	Over 305 – 610	0.65	16.5	0.032	0.81	0.016	0.41

^a 0.015 inch (0.33 mm) for chimneys evaluated to 2100°F

6.1.5 The combustion zone of the fireplace, and other parts in contact with flue gases, shall be of a material equivalent to that of a material specified in Table 6.3.

Table 6.3
Minimum thickness of combustion zone material

Cast refractory or clay tile		Porcelain-coated steel-base metal		Series 300 and types 430 and 446 stainless steel		Type I aluminum coated steel		Cast iron ^a		Low carbon steel ^a	
Inch	mm	Inch	mm	Inch	mm	Inch	mm	Inch	mm	Inch	mm
0.400	10.16	0.026	0.66	0.012	0.30	0.018	0.46	1/8	3.2	0.093	2.36

^a See notes k and 1 of Table 10.1.

6.1.6 A firestop assembly, spacers or standoffs, a nonstructural part, such as the decorative front surround of a fire chamber, or other nonstructural parts not subjected to the effects of external atmospheric conditions, shall be of zinc coated (galvanized) steel not less than 0.018 inch (0.46 mm) thick. The zinc coating shall comply with the coating designation G60 in Table 1 of the Specification for Steel Sheet, Zinc Coated (Galvanized) or Zinc-Iron Alloy-Coated (Galvannealed) by the Hot-Dip Process, ASTM A653/A653M-94, with not less than 40 percent of the zinc on any side as determined by the minimum single spot test requirements of ASTM A653/A653-96.

6.1.6 revised January 13, 1999

6.1.7 Other parts of a chimney subject to contact by flue gases or flue-gas air mixtures or subject to condensation, at locations beyond the terminus of the flue-gas-conveying conduit, shall be of aluminum-coated steel. The aluminum coating shall be designation Type T1-40 (regular) in Table 1 of Aluminum Coated Type 1 Cold Rolled Steel Sheet, ASTM A463-95, with not less than 0.40 ounce of aluminum coating per square foot (0.12 kg/m²) of steel or equivalent.

Exception: Galvanized steel with a zinc coating complying with the coating designation G90 is not prohibited from being used for parts of a chimney subjected to contact by flue gas or condensation, when evaluated during the Performance Testing of Section 8 and when the temperature limitations of this material shown in Table 10.1 are not exceeded.

6.1.7 revised January 26, 1998

6.1.8 An outer casing or other structural part (exclusive of the flue-gas-conveying conduit):

- a) Whose malfunction or deterioration results in the fire chamber or chimney to collapse or otherwise increase the risk of injury to users; or
- b) That adjoins firestopping material;

shall be of galvanized steel. The galvanized steel shall have a zinc coating complying with the coating designation G90 (former coating Class 1.25 Commercial) in Table 1 of the Specifications for Steel Sheet, Zinc Coated (Galvanized) or Zinc-Iron Alloy-Coated (Galvannealed) by the Hot-Dip Process, ASTM A653/A653M-94, with not less than 40 percent of the zinc on any side, based on the minimum single spot test requirement in this ASTM designation. The weight of zinc coating shall be established in accordance with the Tests for Weight of Coating on Zinc-Coated (Galvanized) Iron or Steel Articles, ASTM A90-95.

6.1.8 revised January 26, 1998

6.1.9 An unreinforced outer casing of a fire chamber or chimney shall be of material equivalent to one of those specified in Table 6.4. An outer casing reinforced by a solid refractory not less than 2 inches (50.8 mm) thick shall be:

- a) Galvanized steel or aluminum-coated steel not less than 0.018 inch (0.46 mm) thick; or
- b) Type 430 stainless steel not less than 0.012 inch (0.30 mm) thick.

**Table 6.4
Minimum thickness of outer casing material**

Nominal inside diameter of flue gas conduit		Galvanized steel				Type T1 – 40 (regular) aluminum coated steel		Series 300 and type 430 436 and 446 stainless steel	
		G-60 coating		G-90 coating					
Inches	mm	Inch	mm	Inch	mm	Inch	mm	Inch	mm
12 or less	305 or less	0.025	0.64	0.018	0.46	0.018	0.46	0.012	0.30
Over 12 – 24	Over 305 – 610	0.030	0.76	0.023	0.58	0.023	0.58	0.016	0.41

6.1.10 Steel with a proprietary coating shall not be used unless it is determined to be equivalent to the coated steel as specified in 6.1.4 – 6.1.9.

No Text on This Page

6.1.11 A painted part made of steel not less than 0.053 inch (1.35 mm) thick, or of cast iron not less than 0.125 inch (3.18 mm) thick, and for use only in the interior of buildings is identified as having corrosion resistance equivalent to that required in 6.1.8.

6.1.12 Thermal insulation material shall be of metal or of a mineral base.

6.1.13 Thermal insulation shall not come into contact with the products of combustion.

6.1.14 Thermal insulation that is not self-supporting shall be applied to solid surfaces so that the insulation does not sag. An adhesive or cement used to attach such material shall retain its adhesive qualities at any temperature the adhesive attains when tested in accordance with these requirements and at 0°F (minus 17.8°C).

6.1.15 A water-absorbing insulating material shall not be subject to wetting by condensation or rain when installed as intended.

6.2 Air duct system

6.2.1 The air duct system portion of:

- a) Circulating warm air ducts; and
- b) Combustion air inlet ducts

shall be constructed entirely of corrosion-resistant sheet metal having a minimum thickness as shown in Table 6.5. See 7.12.1 and 7.12.2.

Exception: Lesser thickness materials classified as Class 0 or Class 1 air ducts, as defined in the Standard for Installation of Warm Air Heating and Air Conditioning Systems, NFPA 90B-1993, and in the requirements in the Standard for Factory-Made Air Ducts and Connectors, UL 181, is used when:

- a) *They comply with the requirements of NFPA 90B and UL 181; and*
- b) *They have been investigated for the intended application.*

Table 6.5
Minimum thickness of sheet metal ducts

Diameter or width, inches	Galvanized steel			Aluminum		Tin plate
	Nominal thickness, inches	Minimum thickness, inches	Minimum thickness, (mm)	Minimum thickness, inches	Minimum thickness, (mm)	Minimum weight per base box, pounds
14 or less	0.016	0.013	(0.330)	0.016	(0.406)	135
Over 14	0.019	0.016	(0.406)	0.020	(0.508)	–
	(b) Exposed Rectangular Ducts:					
14 or less	0.019	0.016	(0.406)	0.020	(0.508)	–
Over 14	0.022	0.019	(0.483)	0.023	(0.584)	–

6.2.2 Asbestos material shall not be used.

6.2.3 Fibrous insulation materials used in an air handling compartment shall comply with the Erosion Test specified in the requirements in the Standard for Factory-Made Air Ducts and Connectors, UL 181.

7 Assembly

7.1 General

7.1.1 A fireplace shall consist of all the essential parts required for the intended installation of a complete fireplace and its chimney. Each part of the assembly shall be constructed for ready attachment of one to the other without requiring alteration by the installer, such as by cutting, threading, drilling, welding, or similar tasks.

Exception: An assembly or component part intended to be cut to length or to be fitted by the installer shall be provided when means are furnished for joining any altered part to a companion part or assembly. All fasteners required to complete the assembly shall be provided with the product by the manufacturer. Drilling shall not occur unless:

- a) The drilling operation does not weaken the assembly or penetrate into the fire chamber; and*
- b) The size of the required drill bit is specified and the instructions clearly describe the locations to be drilled, such as by the use of drawings, descriptions, or templates.*

7.1.2 Two or more parts or subassemblies that bear a definite relationship to each other in the intended application shall:

- a) Be arranged and constructed to meet the intent of the requirement to be incorporated into the complete assembly, without requirement of alteration or alignment, and only in the correct relationship with each other; or
- b) Be assembled and shipped from the factory as one unit.

7.1.3 To comply with the requirements of 7.1.1 and 7.1.2, a chimney-pipe section comprised of a flue-gas-conveying conduit, formed insulation or other intermediate assembly, and an outer jacket, which are separable, shall be preassembled and packaged as one unit. A firestop-spacer assembly shall be constructed in two halves, and shall be packaged as one unit. In such cases, each separable part is to be completely formed, including the jointing of all seams.

7.1.4 The construction of a fireplace shall not void the firestopping required between spaces of a building when the fireplace and its chimney are installed in accordance with the manufacturer's instructions.

7.1.5 The fireplace shall not incorporate provisions for placing combustible materials, or for supporting a combustible mantel, at distances from the fireplace opening less than those dimensions specified in the installation instructions.

7.2 Joints

7.2.1 Parts shall be joined and secured so that they do not disengage when tested in accordance with these requirements.

7.2.2 When screws are employed to join assemblies during installation, the assemblies to be joined shall provide for use of screws without having to be punched or drilled, except for parts as referenced in 7.1.1. When cement is employed for this purpose, the cement shall be a quick-setting type. Cement, screws, and instructions shall be furnished. A screw shall not extend into a flue-gas passage.

7.2.3 A joint, fabricated in accordance with the manufacturer's instructions, shall limit the leakage of combustion by-products through the joint. With reference to 6.1.13, there shall be no leakage in areas where thermal insulation is installed. There shall also be no leakage from the exterior of the assembly.

7.2.3 revised January 13, 1999

7.2.4 A joint shall not significantly reduce the capacity of the chimney.

7.2.5 A joint shall not retain condensation. Condensation also shall not flow from the interior to the exterior of the fuel-gas-conveying conduit.

7.2.5 revised January 13, 1999

7.3 Firestop spacers

7.3.1 A chimney intended to pass through a floor or ceiling of a building shall be provided with an assembly constructed to provide firestopping at the framed joist opening and to establish and maintain required minimum clearances between chimney sections and combustible construction in this area. Spacers shall have strength and bearing surface to maintain the required clearance from chimney sections to joists and ceiling and floor material.

7.3.2 A firestop shall provide complete firestopping when the assembly is installed in a framed joist opening that is 1/2 inch (12.7 mm) greater on each side than the opening for which the assembly is intended. A spacer shall provide for continuous interference around the perimeter of the construction for a height of not less than 1 inch (25 mm). The inside diameter of the firestop opening shall not be more than 1/8 inch (3.2 mm) greater than the outside diameter of the chimney pipe, including chimney joints and raised projections.

7.4 Support assembly

7.4.1 A support assembly, such as a ceiling or floor jack, when furnished, shall establish and maintain the minimum required clearance between a chimney section and combustible construction. A chimney support assembly shall be provided at changes in chimney direction from diagonal to vertical and at intermediate points on diagonal runs, as specified in the installation instructions.

7.4.2 A support assembly intended to be secured by nails or screws shall be arranged so that such loads on the holding means are shear loads.

7.5 Radiation shield

7.5.1 A radiation shield provided to comply with the maximum temperature limits of these requirements for floor or ceiling structures shall:

- a) Be an integral part of a firestop-spacer or support assembly; and

- b) Provide a continuous barrier for a vertical distance, referenced to the ceiling or floor level, of not less than 10 inches (254 mm).

The assembly shall fit into a framed joist area not larger than the sum of 1/2 inch (12.7 mm) greater on each side than the outside diameter of the chimney and twice the dimension to be specified in the installation instructions for clearance between chimney sections and combustible enclosures.

7.5.2 Parts of a firestop-spacer or support assembly that are not intended to provide shielding from radiation to combustible construction are not identified to be radiation shields.

7.5.3 A radiation shield provided to obtain compliance with the maximum temperature limits of these requirements for roof structures shall not be employed in a roof or other terminating assembly intended to be altered in the field when such alteration requires the shifting or relocation of the shield.

7.6 Flue damper

7.6.1 A fireplace flue-gas outlet damper operated by a linkage or other mechanism shall be constructed so that breakage of a part, after fire testing (see Sections 12 – 14), results in the damper to move to its designed open position. When the fireplace is provided with a flue-gas outlet damper that is placed in, and remains in, any position from open to closed, the following considerations apply:

- a) During the fire tests, see Sections 12 – 14, spillage of products of combustion (flame or smoke) or temperatures in excess of established requirements shall not occur while the damper is in the fully open position and the doors are open.
- b) During the fire tests, spillage of products of combustion or temperatures in excess of established requirements shall not occur while the damper is in the fully open position or at any intermediate position (other than fully closed) and the doors are closed.
- c) The unit shall be marked with a permanent marking located at or near the fuel feeding door advising users to open the damper before opening the doors. See 52.10.
- d) The damper control knob shall be located external to the fire chamber. The maximum temperature on the damper control knob(s) shall not exceed the value specified in Table 10.1.
- e) Doors shall be provided for use with the unit.

Exception No. 1: (c) and (d) do not apply when other means are utilized to open the damper before the doors are opened.

Exception No. 2: (c) and (d) do not apply when the unit does not spill products of combustion when the damper is in any position other than fully closed.

7.7 Chimney caps

7.7.1 A cap shall be provided to resist the entrance of debris and excess rain into the flue-gas-conveying conduit and into any cooling-air passage terminating exterior to the building. See Rain Test, Section 19.

7.7.2 A cap shall be constructed so that leaves and debris falling or blown onto it are not retained so as to obstruct flue-gas or cooling-air passages. A cap shall be constructed to resist accumulation of soot that obstructs flue-gas or cooling-air passages. An opening, other than one for flue gas passage, shall not have an entrance of a 1/2 inch (12.7 mm) diameter rod.

7.7.3 A cap shall be removable and replaceable, without bending or deforming the chimney or parts thereof, by the use of common hand tools, such as flat blade or Phillips head screwdrivers, hand pliers, wrenches, and other tools, to meet the intent of the requirement for chimney cleaning in accordance with the operating instructions.

7.8 Roof assemblies

7.8.1 The height of a roof assembly shall be such that the flue-gas exit is not less than 3 feet (0.9 m) above the highest point where the chimney passes through the roof.

7.8.2 A roof assembly installed in accordance with the installation instructions shall resist the entrance of excess water and debris into the building. See Rain Test, Section 19.

7.8.3 A roof assembly shall resist the accumulation of soot and debris therein when such accumulation obstructs flue-gas or cooling-air passages. An opening, other than one for flue gas passage, shall not have an entrance of a 1/2 inch (12.7 mm) diameter rod.

7.8.4 *Deleted January 13, 1999*

7.8.5 A roof flashing assembly that provides for ventilation shall be constructed so that soot or debris shall not accumulate on the assembly to the extent that ventilation openings intended to remain open are obstructed. (See also the requirements of 7.3.2 and 9.30, which apply to openings between the chimney and the flashing, and between the flashing and the test enclosure.) See Figure 7.1, which illustrates a typical roof flashing housing assembly. The ventilation shall be provided by one or more fixed openings surrounding the chimney and the assembly shall comply with all of the following:

- a) The openings shall not permit entrance of a 1/4 inch (6.4 mm) diameter rod.
- b) The lowest portion of the opening in the flashing shall not be less than 6 inches (152 mm) above the roof, measured perpendicular to the roof.
- c) The assembly shall incorporate a storm collar.
- d) The intended openings shall be maintained by means of spacers factory-attached to the flashing, or designed openings in the assembly.

7.9 Firescreens

7.9.1 A firescreen shall not permit entrance of a 1/4 inch (6.4 mm) diameter rod through any opening. The firescreen shall be capable of covering all fire chamber openings within 1/4 inch (6.4 mm) of each edge and shall be furnished by the manufacturer as part of the fireplace, even if doors are provided.

Revised 7.9.1 effective February 25, 1999

7.10 Chimney elbows

7.10.1 When a chimney assembly incorporates elbows, no part of the chimney shall be at an angle of more than 30 degrees from the vertical at any point in the assembly.

Figure 7.1
Typical roof flashing housing assembly

Figure 7.1 revised January 26, 1998

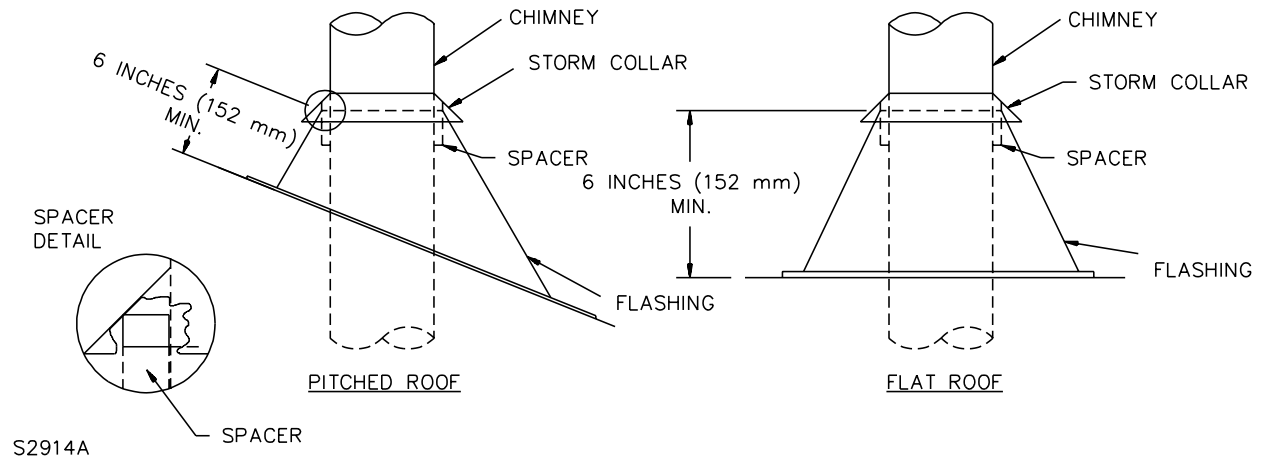

7.11 Gas pipe provision

7.11.1 A fireplace intended for connection to a decorative gas appliance shall incorporate a metal conduit sized to contain a 1/2 inch nominal diameter pipe. The conduit shall be arranged so that no field modification is required to the fireplace or related parts other than removal of a knockout and insulating material in the conduit.

7.12 Air duct system

7.12.1 The combustion air inlet system shall have zero clearance to combustible construction.

7.12.2 The combustion air inlet shall prevent material from dropping into the inlet and also prevent rodents from entering from the outside by use of a minimum 20 gauge wire mesh having openings not larger than 1/4 by 1/4 inch (6.4 by 6.4 mm).

7.12.2 revised January 13, 1999

7.13 Handles

7.13.1 Those portions of a handle or knob that are subject to contact shall not have sharp edges.

7.14 Integral grates

7.14.1 An integral grate that effectively reduces the hearth area as defined by 13.6 shall be constructed of 1/2 inch (12.7 mm) minimum steel bar stock or the equivalent, and the grate bottom shall be readily replaceable.

Exception: The grate bottom is not required to be readily replaceable when:

- a) The grate is unitary and attached in a manner requiring a tool for removal; and*
- b) The fireplace is marked with the word "WARNING" and the following or equivalent statement, "Risk of Fire Damage. Replace grate with (manufacturer's name) Model (manufacturer's model number) grate."*

7.15 Openings in chimney walls

7.15.1 Openings for air flow between air in a chimney chase and air located between chimney walls are not prohibited in the chimney walls; they shall not be provided in the flue-gas conduit wall. Such openings shall not impair the structural integrity of the chimney.

7.15.2 The openings specified in 7.15.1 shall be an integral part of the fireplace chimney transition. The fireplace chimney transition is the part of the fireplace where the first piece of the chimney is attached.

No Text on This Page

PERFORMANCE

8 General

8.1 When a fireplace is tested in accordance with these requirements, specified temperatures to combustible construction adjoining the fire chamber and its chimney, and in the hearth extension floor area, shall be maintained; no part shall attain a temperature that damages required corrosion protection or results in creeping, distortion, sagging, or similar damage; resistance to damage by wind, rain, and handling shall be demonstrated and the creation of draft by natural thermal effects shall prevent gas and flame from being drawn out of the fireplace.

8.2 After being tested in accordance with the Thermal Shock Test (see 11.2.1 – 11.2.5); Temperature Test – 1700°F Flue Gases (see 11.3.1 – 11.3.4) or Temperature Test – 2100°F Flue Gases (see 11.4.1 – 11.4.5), as appropriate; Radiant Fire Test, Section 12; Brand Fire Test, Section 13; and Flash Fire Test, Section 14; a fireplace and chimney shall be capable of being further used. After completion of these tests, the fireplace is to be permitted to cool to room temperature and then be subjected to the Support Test, Section 15; Fire Chamber Strength Test, Section 16; and Chimney Strength Test, Section 17.

8.3 Compliance with the requirements in 8.2 include the following:

- a) No part of the chimney shall become damaged or permanently distorted to an extent that the part or the chimney assembly does not continue to function as intended.
- b) The effectiveness of any required protective coating or finish on metal parts shall not be reduced.
- c) A ceramic material shall show no evidence of cracking, disintegration, or spalling to the extent that the serviceability of any part of an assembly is impaired.
- d) Cracks shall not be observable in porcelain enamel used as a required protective coating when the surface is examined under a microscope of 60 magnification.
- e) The reflectivity of a surface shall not be impaired when the reflectivity is utilized to reduce the risk of fire.
- f) Burning or scaling of metal parts shall not be evident upon visual observation.
- g) The effectiveness of insulating material shall not be reduced.

8.4 Thermal insulation, as employed, shall comply with the following requirements during and following tests on the fireplace and its chimney in accordance with the requirements in this standard.

- a) The products resulting from the combustion or volatilization of any combustible binder shall not be discharged to the living area.
- b) The insulating material shall remain in its intended position.
- c) The thermal conductivity of the insulating materials shall not be increased.
- d) The thermal insulation shall not show evidence of softening, melting, or other evidence of malfunction or deterioration.

8.5 During these tests, temperatures are to be determined with fireplace screens withdrawn (open).

9 Test Installations

9.1 Tests are to be conducted as described herein on each type of fireplace. When a fireplace is manufactured in more than one size, tests are to be conducted on as many representative sizes as required to determine compliance of all sizes with these requirements.

9.2 Fireplaces having doors shall be tested with the doors fully open and fully closed. During the tests, the fireplace shall be operated with any draft control (inlet air) dampers adjusted to yield maximum temperatures.

9.3 Fireplaces are to be tested as described in Radiant Fire Test, Section 12; Brand Fire Test, Section 13; and Flash Fire Test, Section 14, using the maximum and minimum chimney height specified by the manufacturer. Tests are also to be conducted using an intermediate height chimney, when the assembly having an intermediate height develops higher temperatures.

9.4 The fireplace is to be installed in a structure similar to that illustrated by Figures 9.1, 9.2, and 9.3 and constructed to accommodate the fireplace to be tested. Combustible enclosure materials and a mantel (when applicable) are to be placed in proximity to the fireplace in accordance with the minimum distances specified in the installation instructions.

9.5 When the manufacturer's installation instructions specify the use of elbows in a chimney run (a chimney run shall not exceed an angle of 30 degrees from the vertical), the assembly shall be erected to represent severe elbow configuration(s) specified in the manufacturer's installation instructions. A typical test structure with elbows is shown in Figure 9.3.

9.6 The test structure is to be free of extraneous drafts and the fireplace chimney is to exhaust into the same space, or into a space freely communicating with the space, from which the combustion air is taken. A typical room with a test structure is shown in Figure 9.1.

9.7 The temperature of the entire test structure shall be between 60 and 90°F (16 and 32°C) at the beginning of the Radiant and Brand Fire Tests.

9.8 The room in which the test structure is erected is to be such that during any one test the room temperature does not increase by more than 20°F (11°C) above the room temperature recorded at the beginning of the test.

9.9 Ventilating, combustion, or cooling-air openings into the fireplace assembly are to be sealed unless the openings comply with all of the following when such openings are incorporated into the fireplace assembly:

- a) The openings are more than 1-1/2 inches (38.1 mm) above the floor and are otherwise arranged so that unintentional closure does not occur;
- b) The openings are blocked by the user to overcome a nuisance (such as downdrafts, a cold room, or an overheated room);
- c) The air is drawn from the room in which the fireplace is installed and is discharged into the same room or into the flue-gas passageway below the damper; and

d) The air is drawn into the fireplace through the chimney at the cap and discharged into a separate discharge passageway of the chimney, or the fire chamber assembly or flue-gas passageway, or both, prior to the first chimney section.

9.9 revised January 13, 1999

Figure 9.1
Typical test structure within test room

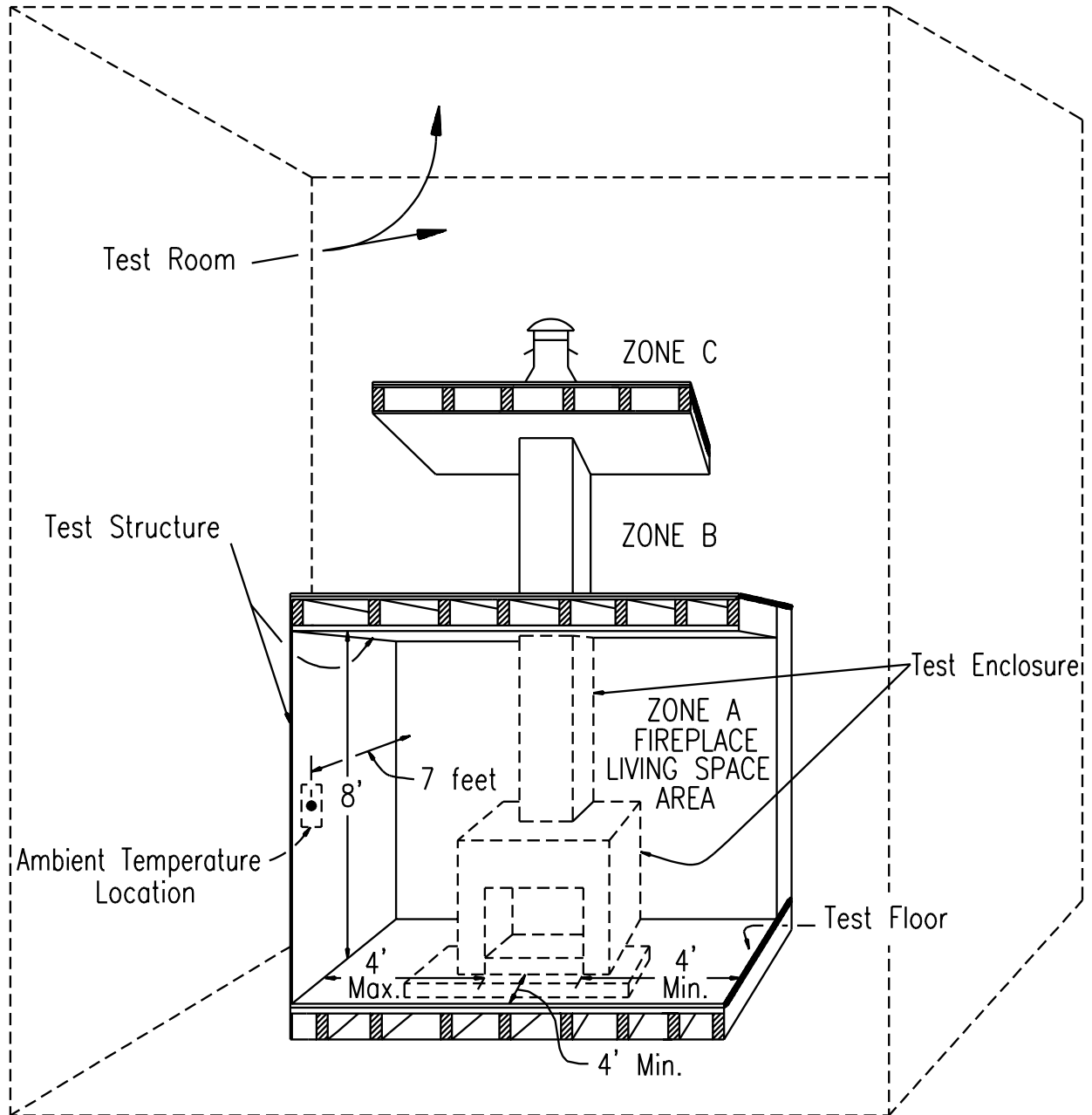

Note: 4 feet = 1.2 m
 7 feet = 2.1 m
 8 feet = 2.4 m

S2016

Figure 9.2
Typical test structure details (side view)

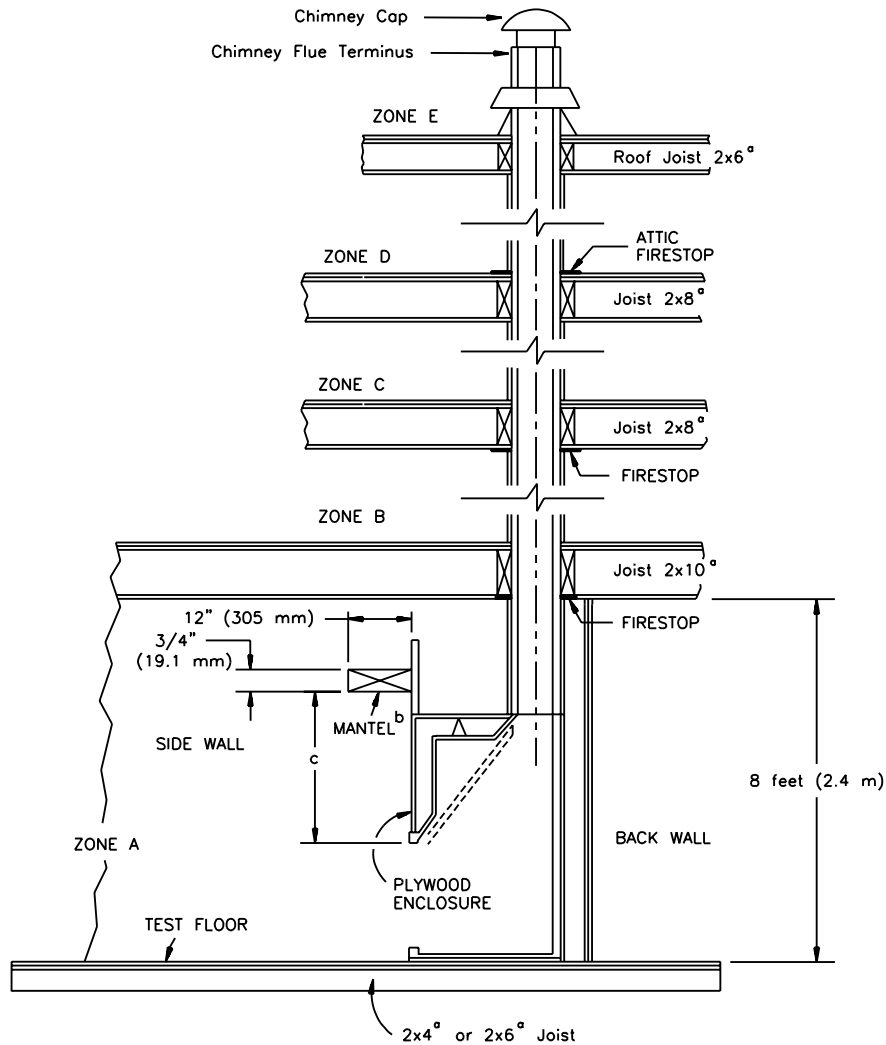

S2017A

All floor and roof joists are to be framed four sides at chimney opening.

All ceiling, floor, and roof material is to be cut flush with inside of all framed joist openings.

Chimney shown totally enclosed at zero clearance.

a Nominal sizes.

b Mantel is used only when fireplace is intended for use with a mantel.

c Minimum distance above fireplace opening specified in installation instructions.

d Mantel depth as specified in the installation instructions.

No Text on This Page

Figure 9.3
Test structure incorporating chimney elbows (front view)

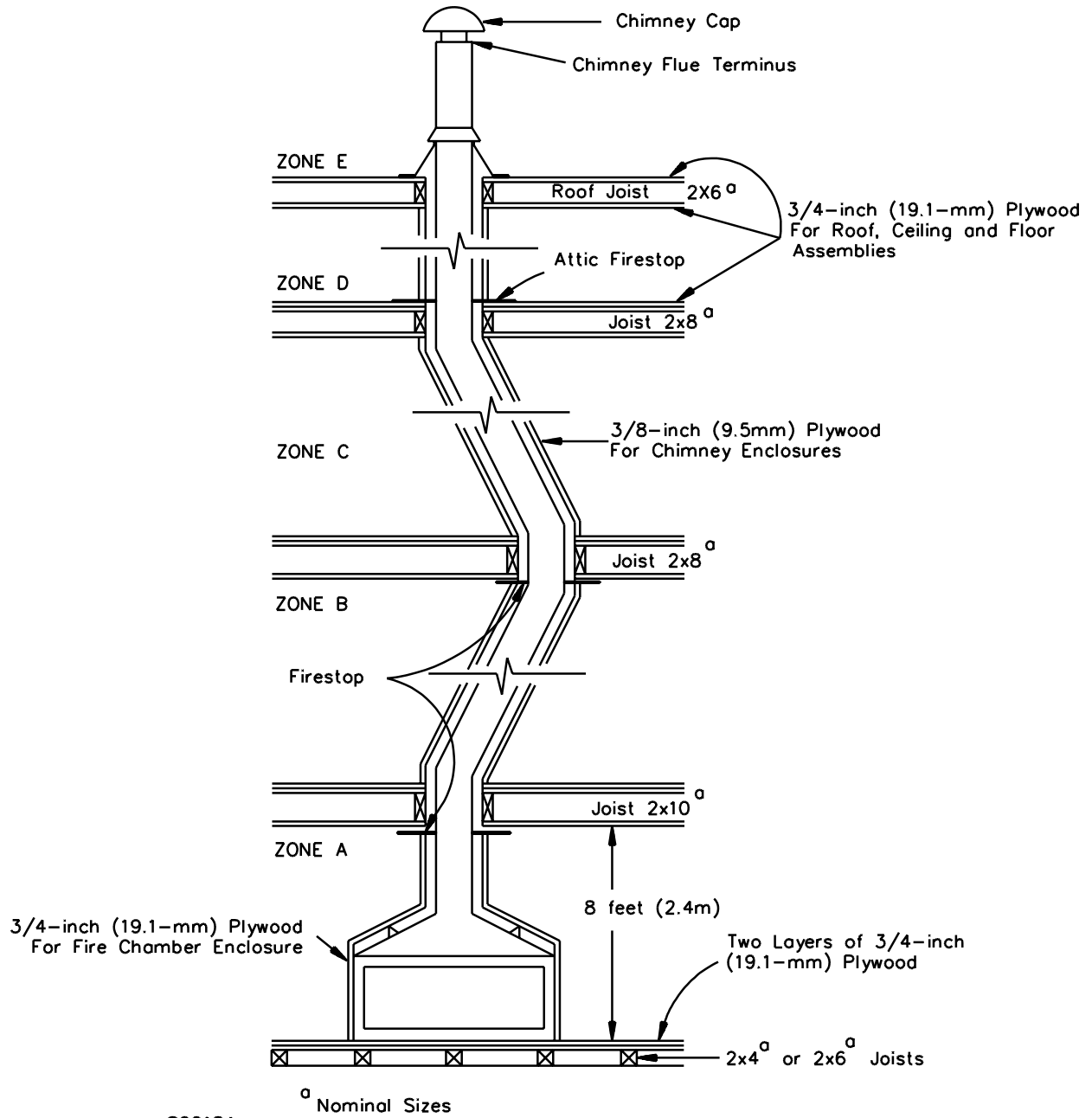

S2018A

9.10 When a fire chamber and chimney are intended to draw air from the outside of a building to cool the assembly, the test structure is to provide means for maintaining the temperature of such air between 60 and 90°F (21 and 32°C) during all temperature tests.

9.11 The test chimney of the fireplace is to consist of a vertical assembly composed of standard chimney sections and other furnished parts erected according to the manufacturer's installation instructions. The top of the test chimney is to be terminated by the roof assembly and cap when these are provided as a functional part of the chimney. The flue outlet of the test chimney is to terminate 3 feet (0.9 m) above the roof. Other functional parts of the chimney, such as a support, firestop-spacer, are to be used during the test.

9.12 That part of the test structure representing the living-space area in which the fireplace is to be installed is to consist of a back wall, one side wall, a combustible floor, and a typical ceiling and floor construction. A typical test installation is shown in Figure 9.1.

9.13 The combustible floor below the fireplace is to consist of two layers of 3/4-inch (19.1-mm) thick plywood over trade size 2- by 4-inch [nominal 1-1/2 by 3-1/2 inches (38.1 by 89 mm)] or trade size 2- by 6-inch [nominal 1-1/2 by 5-1/2 inches (38.1 by 140 mm)] floor supports placed on 16-inch (406-mm) centers.

9.14 The side wall and back wall are to consist of one thickness of 3/4 inch (19.1 mm) plywood.

9.15 The ceiling and floor constructions immediately above the fireplace are to be constructed with trade size 2- by 10-inch [nominal 1-1/2 by 9-1/2 inches (38.1 by 241 mm)] joists. Joists at intermediate floors and at the roof are to be as indicated in Figure 9.2. A ceiling is to consist of one thickness of 3/4-inch (19.1-mm) plywood. Flooring over the joists is to consist of two layers of 3/4-inch plywood. Roofing is to consist of one layer of 3/4-inch plywood.

9.16 The floor under, and the ceiling above, the fireplace are to be 8 feet (2.4 m) apart and are to extend at least 4 feet (1.2 m) in front of the fireplace opening and at least 8 feet in front of the back wall. The side wall is to be perpendicular to the back wall and located at the minimum distance specified by the manufacturer and not more than 4 feet from the nearest side of the fireplace opening. The floor, ceiling, and back wall are to join the side wall. The floor, ceiling, and back wall are to extend at least 4 feet beyond the side of the fireplace opening which is opposite the side wall.

9.17 The fireplace is to be located in relation to the back wall of the test structure in accordance with the minimum clearances specified by the installation instructions. Other areas of the fireplace in contact with combustible construction, when the fireplace is recessed or enclosed, such as the sides, bottom, and top, are to be enclosed with one layer of 3/4-inch (19.1-mm) plywood at the minimum clearances specified by the installation instructions.

9.18 When installation instructions specify areas not to be in contact with combustible material, those areas are to be fully exposed to the living space in which the fireplace is located.

9.19 The face areas of a fireplace that are intended to be covered with decorative materials, such as slate, tile, or marble are to be covered with such materials when provided with the fireplace, otherwise, with noncombustible material having a 3/8-inch (9.5-mm) minimum thickness.

9.20 Unless the manufacturer's installation instructions specify that the fire chamber hood or chimney section above the fire chamber and within the living space in which the fireplace is located are to be fully exposed, the chimney section is to be enclosed with 3/8-inch (9.5-mm) thick plywood, and the chamber hood section is to be enclosed with 3/4-inch (19.1-mm) thick plywood extending to the back of the test structure.

9.21 When a fireplace is provided with air ducts, the fireplace is to be tested with the ducts installed and with the specified air space provided above the fire chamber. This installation method, for example, "chase installation," shall be illustrated in the installation instructions.

9.22 When installation of air ducts is not required, the fireplace is to be tested as follows:

- a) Air ducts are to be installed and the specified air space is to be provided above the fire chamber; and
- b) Air outlets on the fire chamber are to be capped with capping devices provided with the fireplace and the fireplace is to be tested both with and without the manufacturer's specified air space above the fire chamber.

9.23 Combustion outside air kits, when provided, shall be installed and tested in each configuration illustrated in the manufacturer's installation instructions. Each configuration shall be investigated with the fireplace doors (when provided) fully open and closed. The combustion outside air damper control and termination shall be sealed and open during the investigation of each configuration. Each configuration shall be investigated until it is demonstrated that the maximum temperatures have been attained. Refer to Figure 9.11 for typical configurations and thermocouple locations.

9.23 revised August 25, 1997

9.24 Plywood enclosure material for the chimney section is to be placed vertically, horizontally, and diagonally to provide clearance to the enclosure of 0, 1/2, 1, 1-1/2, or 2 inches (0, 12.7, 25.4, 38.1, or 50.8 mm) as specified by the manufacturer's installation instructions. These specified clearances are to be measured between the outer surfaces of the chimney section and the interior surfaces of the enclosing material. The plywood enclosure material for the fire chamber is to be placed vertically and horizontally against points of intended contact, or at the minimum air space clearance at the back and sides as marked on the fire chamber. See 52.6.

9.25 The chimney of the fireplace is to be totally encased for its full height within all stories and attic space. Fireplace chimneys are to be tested on the basis of clearance from the enclosure of 0, 1/2, 1, 1-1/2, or 2 inches (0, 12.7, 25.4, 38.1, or 50.8 mm) as specified by the manufacturer's installation instructions, and measured between the outer surface of the chimney-pipe sections and the interior surfaces of the enclosing material. These clearances are designated by the dimensions "X" in Figures 9.6 to 9.10, inclusive. The chimney enclosure material is to be 3/8-inch (9.5-mm) thick plywood and is to be closed at each floor-joist level by the installation of a manufacturer's firestop or firestop-spacer assembly. Such assemblies are to be placed at the ceiling line of each floor-joist level except that at the joist level serving the attic space the assembly is to be placed on top of the attic-space floor material. See Figures 9.2, 9.6, and 9.7.

9.26 For test purposes, the inside diameter of the firestop opening shall not be more than 1/8 inch (3.17 mm) greater than the minimum outside diameter of the chimney pipe.

9.27 When the installation instructions specify the use of a combustible chase enclosure for the chimney sections installed above the roof, the fireplace chimney is to be encased in a plywood enclosure above the roof. The plywood enclosure material for the chimney sections is to be placed vertically to provide clearance to the enclosure as marked on the chimney sections. The specified clearances are to be measured between the outer surface of the chimney section and the interior surface of the enclosing material. The chimney enclosure material is to be 3/8 inch (9.5 mm) thick plywood with flat black paint on the inside surfaces. A horizontal chase extension consisting of a double layer of trade size 2 by 4 inch [nominal 1 1/2 by 3 1/2 inches (38.1 mm by 89 mm)] joists covered with 3/8 inch (9.5 mm) plywood material, and located within the vertical chase enclosure as illustrated by Figure 9.4. The chase extension is to be closed at the top by the method described in the manufacturer's installation instructions. Refer to Figures 9.4 and 9.5 for thermocouple locations.

9.28 The test enclosure material at each floor-joist level is to be of trade size 2- by 10- or 8-[nominal 1-1/2 by 9-1/4 or 7-1/4 inches (38.1 by 235 or 184 mm)] lumber, forming a box placed at zero clearance to the chimney sections or to a manufacturer's support or firestop-spacer assembly. The test-enclosure material at the roof-joist level is to be of trade size 2- by 6-inch [nominal 1-1/2 by 5-1/2 inches (38.1 by 140 mm)] lumber forming a box placed at the clearance specified by the manufacturer for enclosures or at the lesser clearance required to provide support means for a roof assembly. See Figures 9.8 – 9.10. All ceiling, floor, and roof material is to be cut flush with the inside of all framed joist openings.

Figure 9.4
Typical thermocouple locations chase top termination assembly

Figure 9.4 revised January 26, 1998

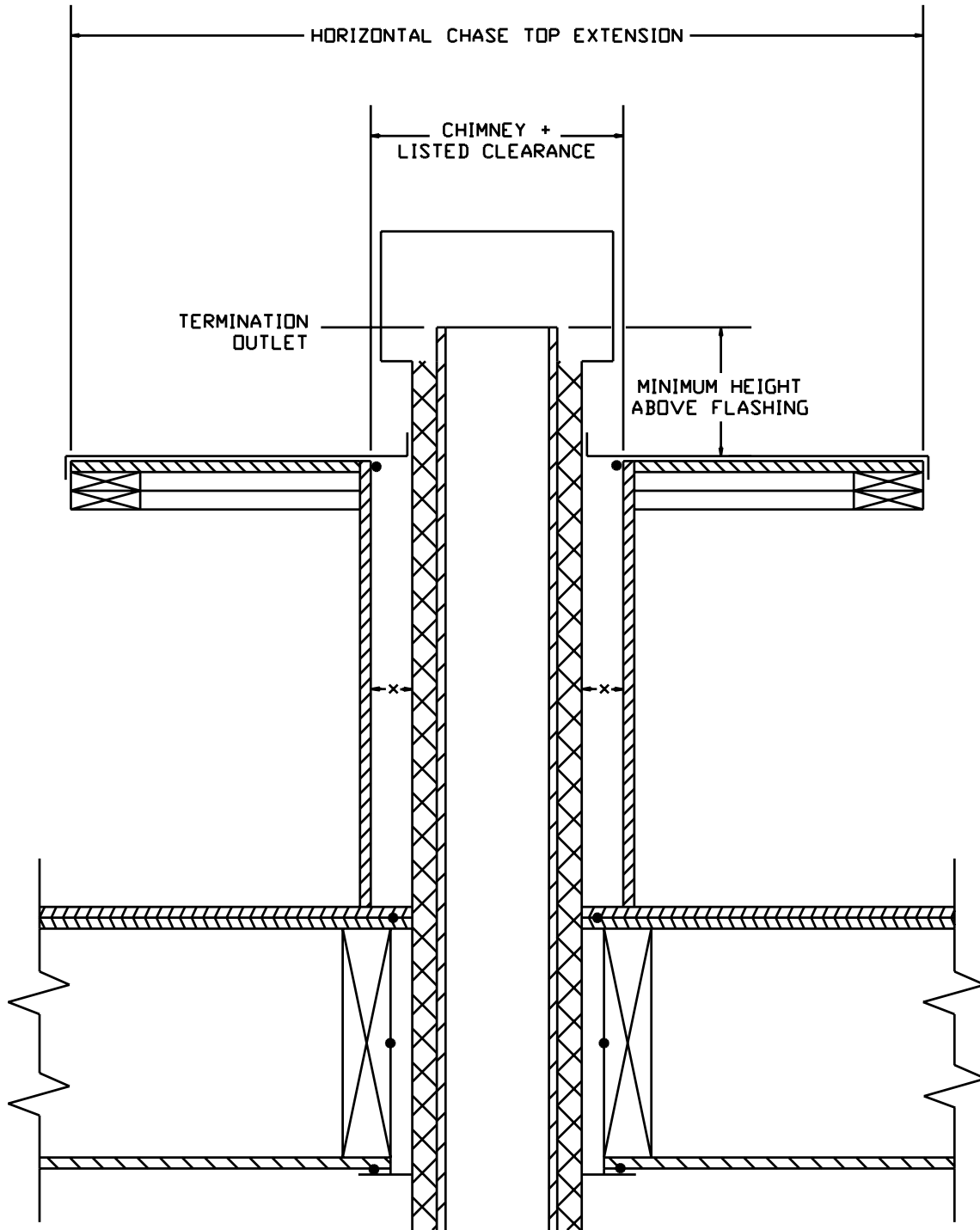

SM1022

● THERMOCOUPLE LOCATION

No Text on This Page

Figure 9.5
Typical thermocouple locations chase top termination assembly

Figure 9.5 deleted August 25, 1997

Figure 9.6
Test structure details for firestop-spacer assembly
(Enclosure shown at specified clearance denoted by "X")

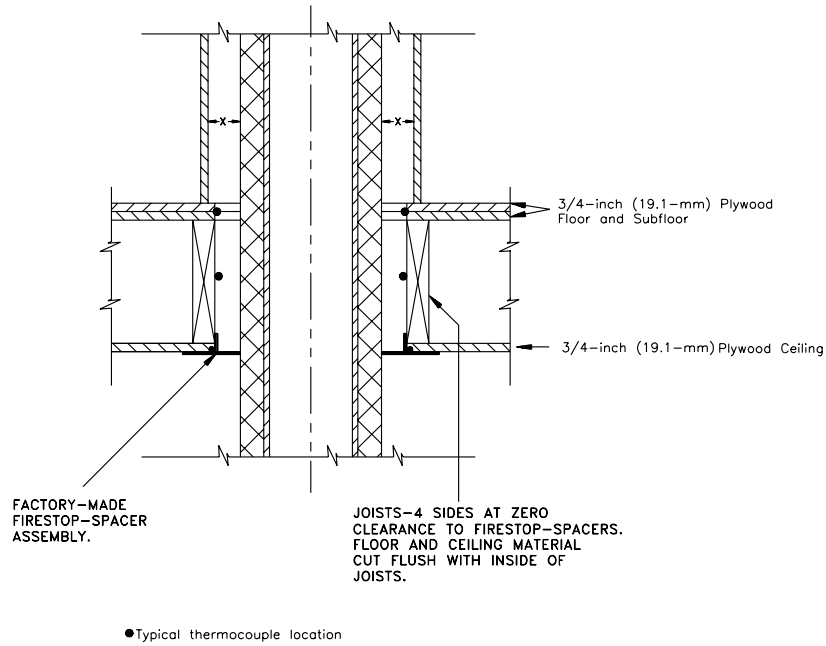

S2019

Figure 9.7
Test structure details for firestop assembly
(Enclosure shown at zero clearance)

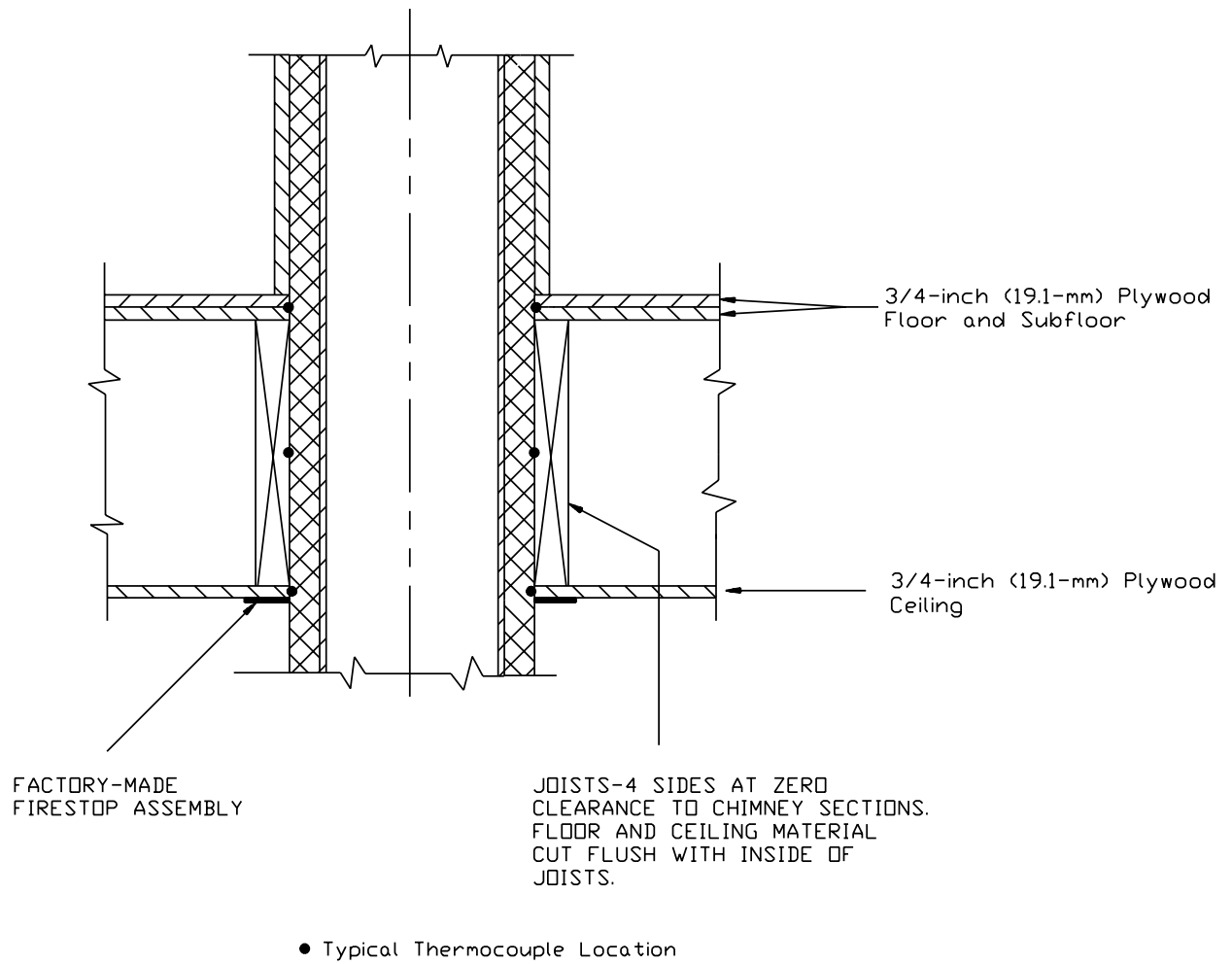

S2020

Figure 9.8
Test structure details for roof assembly
 (Roof assembly larger than roof joist area)

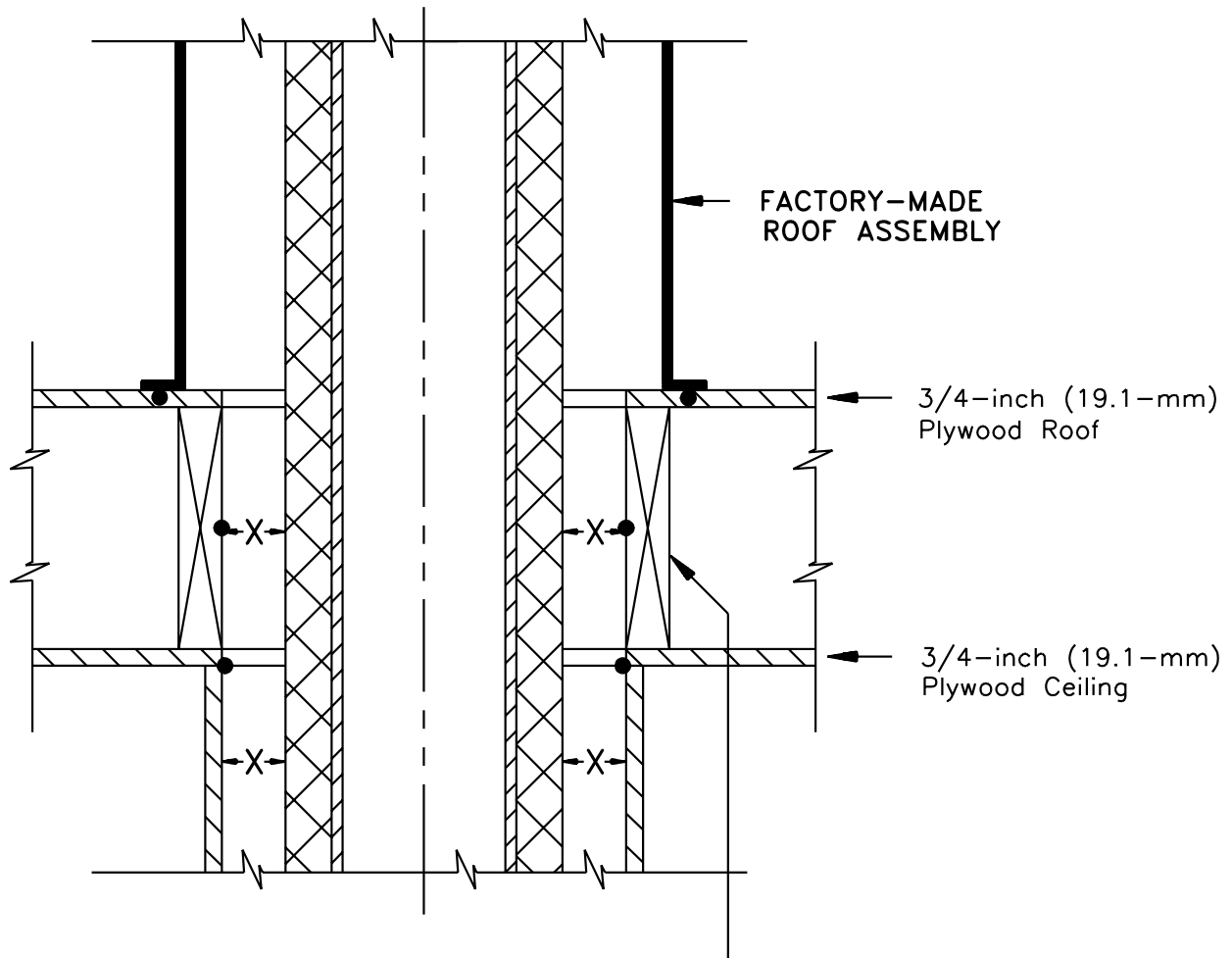

**JOISTS - 4 SIDES AT "X"
 CLEARANCE TO CHIMNEY SECTIONS.
 FLOOR AND CEILING MATERIAL
 CUT FLUSH WITH INSIDE OF
 JOISTS.**

● Typical thermocouple location

S2021

Figure 9.9
Test structure details for roof assembly
 (Roof assembly smaller than enclosure area)

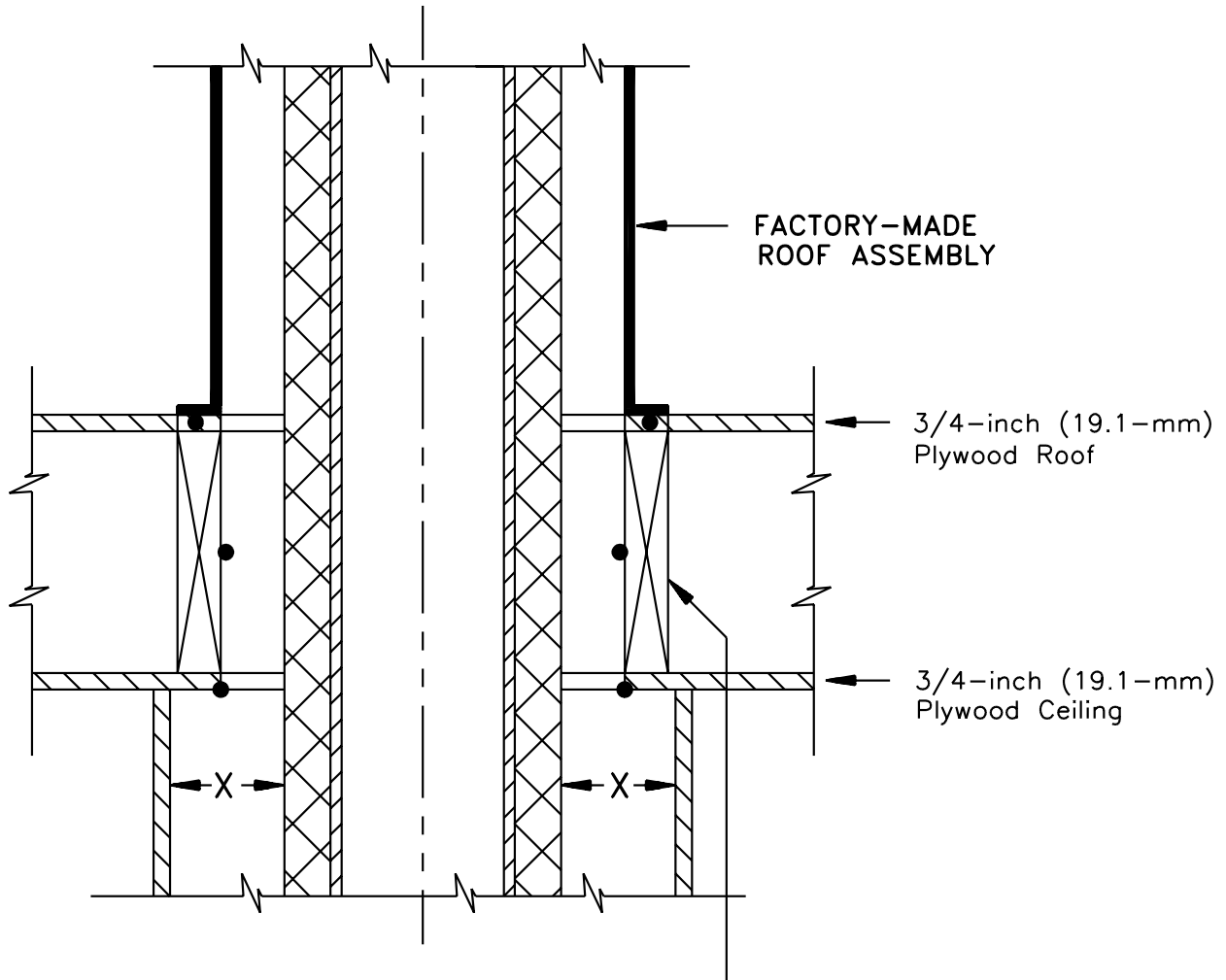

JOISTS - 4 SIDES AT CLEARANCE
 LESS THAN "X" TO CONFORM TO
 SUPPORT REQUIRED FOR ROOF
 ASSEMBLY.

● Typical thermocouple location

S2022

Figure 9.10
Test structure details for roof assembly
 (Roof assembly of type not requiring field alteration to conform to roof line)

Figure 9.10 revised January 26, 1998

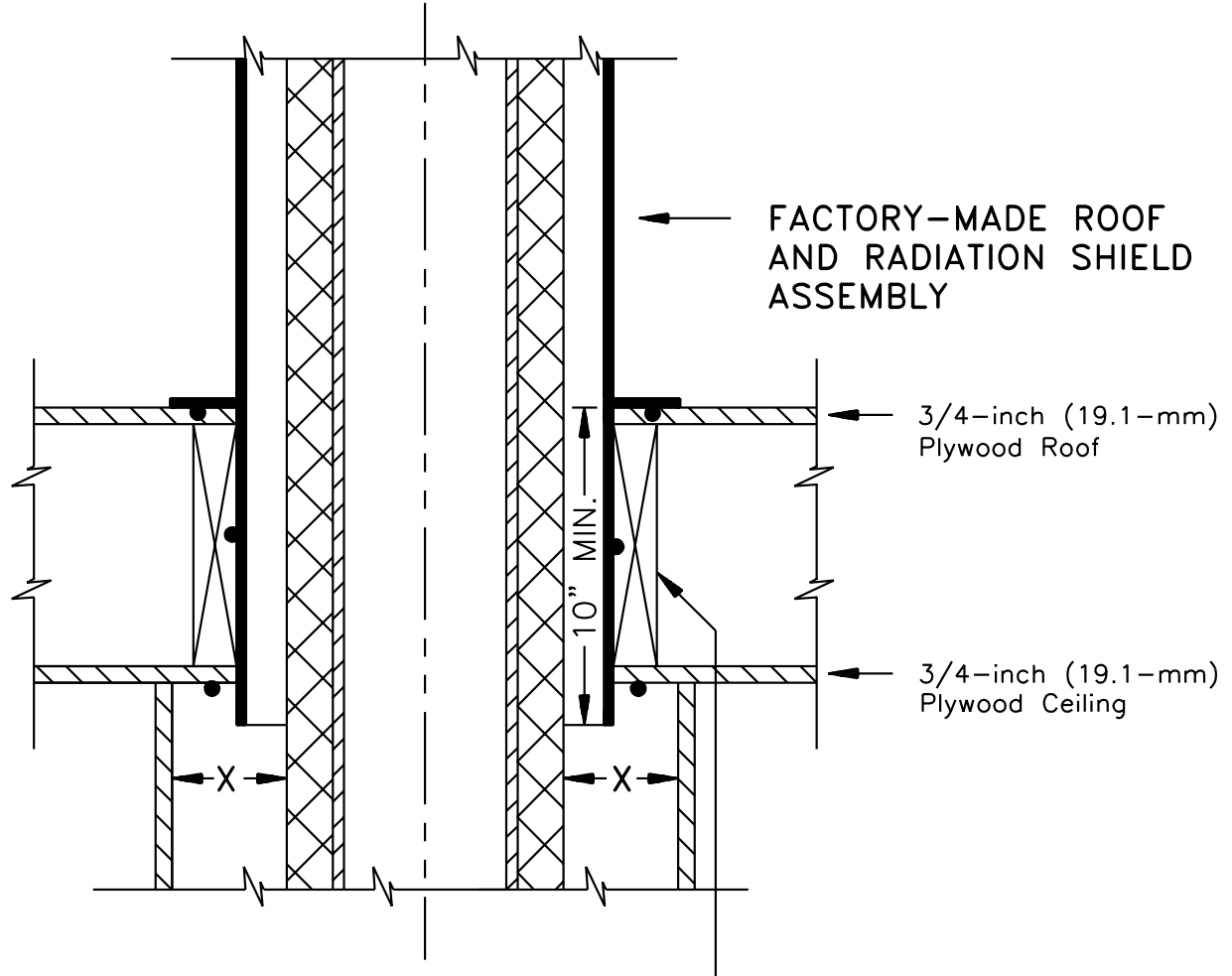

● Typical Thermocouple location

Note: 10 inches = 254 mm

JOISTS - 4 SIDES AT ZERO CLEARANCE TO RADIATION SHIELD. FLOOR AND CEILING MATERIAL CUT FLUSH WITH INSIDE OF JOISTS.

S2023

9.29 The hearth-extension floor area for a fireplace not provided with a factory-built hearth extension is to be covered with the material specified by the manufacturer's installation instructions, and painted flat black.

9.30 The following are to be sealed with plastic-coated or film-faced pressure-sensitive tape lapping the joint by a minimum of 1 inch (25.4 mm) on each side:

- a) Openings between spacers or supports (including firestops) and the test enclosure;
- b) Openings between the flashing and the roof;
- c) Openings between flashing and the chimney;

Exception: The flashing openings are not required to be taped when the opening between the attic firestop and the chimney is sealed.

- d) All joints and openings in the test enclosure; and
- e) All joints intended to be sealed for field installation.

The peel adhesion characteristics of the tape on fibrous (wood) combustible enclosure materials shall comply with the Standard for Test Method for Adhesion of Pressure-Sensitive Tape to Fiberboard at 90 Degree Angle and Constant Stress, ASTM D2860-90, at elevated temperatures of 150°F (66°C).

9.31 All wall surfaces, the floor surface, the ceiling surface, and the inside surface of the plywood enclosure facing the fireplace and chimney are to be painted flat black.

10 Temperature Measurement

10.1 Flue-gas temperatures are to be measured by a thermocouple, such as illustrated by Figure 10.1, inserted to the center line of the flue pipe. The thermocouple is to be located as shown in Figure 11.2 or as described in 11.1.2.

Figure 10.1
Flue-gas thermocouple and support bracket

Figure 10.1 revised January 26, 1998

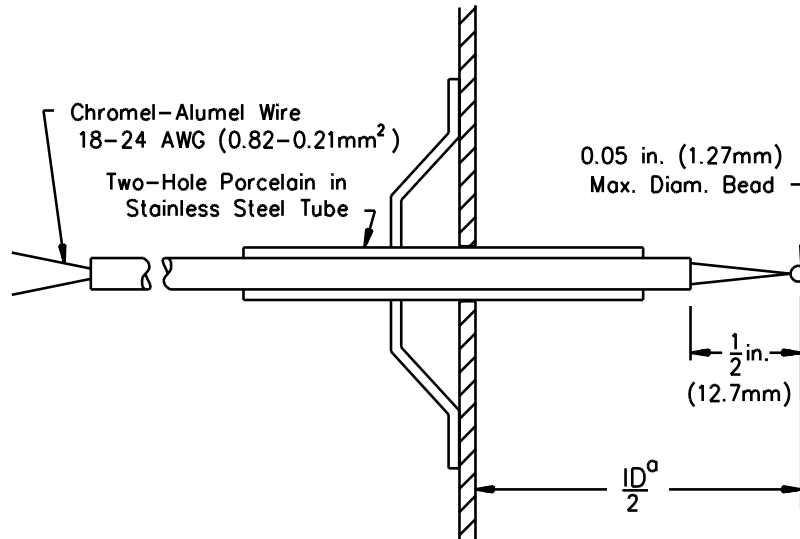

^aID = Internal Diameter of Flue Pipe

S2255

10.2 The thermocouple is to be a Type K (chromel-alumel) of Nos. 18 – 24 AWG (0.82 – 0.21 mm²) wire with an untwisted welded bare lead junction of not more than 0.050 inch (1.27 mm) diameter.

10.3 Temperatures of other than flue gases and metal surfaces are to be measured using either Type K (chromel-alumel) or Type J (iron-constantan) thermocouples of wire not larger than No. 24 AWG (0.21 mm²).

10.4 Temperatures of metal surfaces other than handles and electrical components are to be measured using Type J (iron-constantan) or Type K (chromel-alumel) of No. 18 AWG (0.82 mm) to No. 24 AWG (0.21 mm²).

10.5 The thermocouple wire insulation is to have a temperature use rating higher than the temperatures to which it is subjected during these tests.

10.6 The wiring methods for thermocouple circuitry, including junctions, terminals, switches, plugs, and jacks are to be designed and constructed to provide independent continuous routing of both thermocouple leads to the recording equipment.

10.7 The ambient temperature of a zone is to be determined by a thermocouple located centrally within a vertically oriented 6 inch (152 mm) length of 2 inch steel pipe, aluminum painted, and open at both ends.

10.8 Ambient temperatures are to be determined by shielded thermocouples located within their respective zones (see 10.9 – 10.11) relative to parts of the fireplace, test structure, and flue-gas generator.

10.9 The ambient temperature for Zone A (Figure 9.1) is to be determined by use of a shielded thermocouple located 6 inches (152 mm) away from the side wall, 7 feet (2.1 m) from the back wall, and 4 feet (1.2 m) above the floor.

10.10 The ambient temperatures for Zones B, C, and other zones above Zone A, are to be determined by use of shielded thermocouples located 2 feet (610 mm) away from the front center line of the chimney enclosure and at the midpoint between the floor and ceiling.

10.11 The ambient temperature for the space above a roof line is to be determined by use of a shielded thermocouple located 2 feet (610 mm) away from the front center line of the chimney or roof assembly and 1 foot (305 mm) above the roof.

10.12 When a fireplace assembly is intended to take air from the outside of a building to cool the device, the ambient temperature of the space into which the chimney exhausts is to be measured by use of a shielded thermocouple located on a horizontal plane with the opening provided for the admission of outside air and 3 feet (0.9 m) from the opening. This temperature is to be maintained between 60 and 90°F (16 and 32.2°C) during all temperature tests.

10.13 When a fireplace assembly is intended to take air from the outside of a building for combustion air purposes, the ambient temperature of the space outside of the test assembly enclosure and within the test structure is to be measured by use of a shielded thermocouple located on a horizontal plane with the inlet air opening provided for the admission of outside combustion air and 3 feet (0.9 m) from the opening. This temperature is to be maintained between 60 and 90°F (16 and 32.2°C) during all temperature tests.

10.14 The measurements of temperature rises on the fire chamber, on chimney parts, and on the enclosures and test structure are to be referenced to the recorded ambient temperatures determined as indicated in 10.9 – 10.11.

10.15 Recorded temperature rises on joists and rafters are to be referenced to the average of the recorded ambient temperatures above and below the involved joist or rafter areas.

10.16 Recorded temperature rises on floor or roof material are to be referenced to the ambient temperature recorded above the involved floor or roof areas.

10.17 Recorded temperature rises on ceiling material are to be referenced to the recorded ambient temperature recorded below the involved ceiling area.

10.18 Thermocouples are to be attached to metal surfaces by screws, rivets, silver soldering, brazing, or welding of the tip to the metal surface. See Figure 10.2.

10.19 Thermocouples are to be secured to wood surfaces by the use of staples placed over the insulated portion of the wires. The thermocouple tip is to be depressed into the wood so as to be flush with the wood surface at the point of measurement and held in thermal contact with the surface at that point by the use of pressure-sensitive paper tape. See Figure 10.2.

10.20 Thermocouples are to be attached to nonmetallic or nonwood material surfaces by having the 1/2 inch (12.7 mm) tip and at least 1 inch (25.4 mm) of the lead wires embedded into the material so as to be flush with the surface of the material. Furnace cement is to be smoothed over such indentations to maintain thermal contact.

10.21 Thermocouples are to be attached to surfaces other than those described in 10.18 – 10.20 by being cemented or taped to the surface to maintain thermal contact with the surface. Materials or parts whose temperatures are to be measured are included in Table 10.1. Temperatures on electrical conductors are to be measured on the surfaces of the conductor insulation.

10.22 A minimum number of typical thermocouple locations to be attached to wood surfaces of the fire chamber enclosure is shown in Figure 10.3.

Figure 10.2
Thermocouple installation methods
 THERMOCOUPLE INSTALLATION METHODS

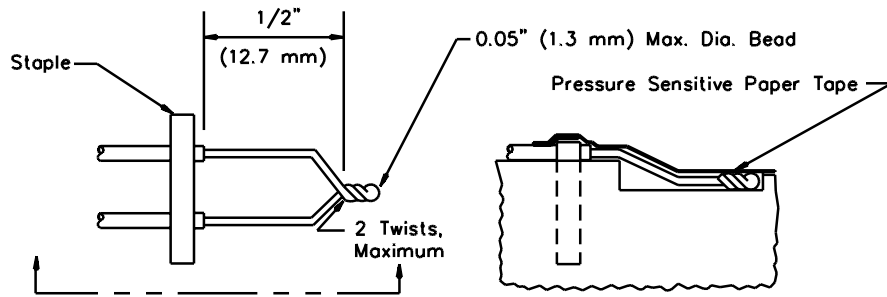

THERMOCOUPLE FOR WOOD SURFACES

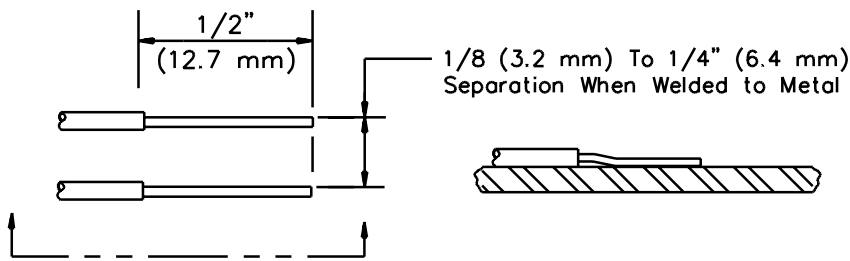

THERMOCOUPLE WELDED TO METAL SURFACE

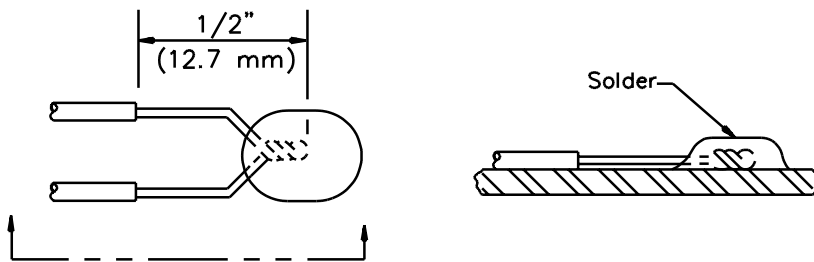

THERMOCOUPLE SOLDERED TO METAL SURFACES

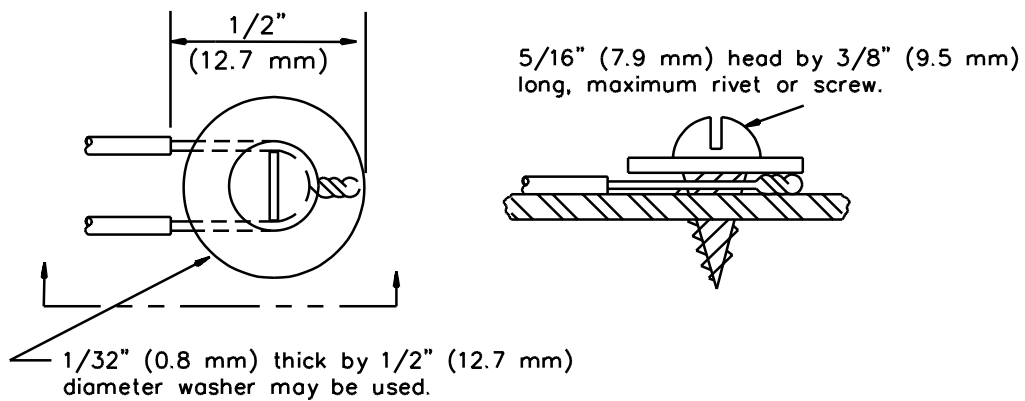

TC-100

THERMOCOUPLE SECURED TO METAL SURFACES

Table 10.1
Maximum temperature rises

Device or material	Column 1		Column 2	
	Degrees		Degrees	
	C	F	C	F
A. Motor ^{a,b,c}				
1. Class A insulation systems on coil windings of alternating-current motors having 7 inches (178 mm) or less in diameter (not including universal motors):				
a. In open motors;				
Thermocouple or resistance method	75	135	115	208
b. In totally enclosed motors;				
Thermocouple or resistance method	80	144	115	208
2. Class A insulation systems on coil windings of alternating-current motors more than 7 inches (178 mm) in diameter and of direct-current and universal motors:				
a. In open motors;				
Thermocouple method	65	117	115	208
Resistance method	75	135	115	208
b. In totally enclosed motors;				
Thermocouple method	70	126	115	208
Resistance method	80	144	115	208
3. Class B insulation systems on coil windings of alternating-current motors 7 inches (178 mm) or less in diameter (not including universal motors):				
a. In open motors;				
Thermocouple or resistance method	95	171	140	252
b. In totally enclosed motors;				
Thermocouple or resistance method	100	180	140	252
4. Class B insulation systems on coil windings of alternating-current motors more than 7 inches (178 mm) in diameter and of direct-current and universal motors.				
a. In open motors;				
Thermocouple method	85	153	140	252
Resistance method	95	171	140	252
b. In totally enclosed motors;				
Thermocouple method	90	162	140	252
Resistance method	100	180	140	252
B. Components ^o				
1. Capacitors:				
a. Electrolytic types ^c	40	72	(Not specified)	
b. Other types ^d	65	117		

Table 10.1 Continued

Device or material	Column 1		Column 2	
	Degrees		Degrees	
	C	F	C	F
2. Relay, solenoid, and other coils with:				
a. Class 105 insulated systems;				
Thermocouple method	65	117	115	207
Resistance method	85	153	115	207
b. Class 130 insulated systems;				
Thermocouple method	85	153	140	252
Resistance method	105	189	140	252
3. Transformer enclosures ^b with:				
a. Class 2 transformers	60	108	85	153
b. Power and ignition transformers	65	117	90	162
C. Insulated Conductors ^{e,f,o}				
1. Appliance wiring material				
75°C rating	50	90	65	117
80°C rating	55	99	70	126
90°C rating	65	117	80	144
105°C rating	80	144	95	171
200°C rating	175	315	200	360
250°C rating	225	406	250	450
2. Flexible cord – Types SO, ST, SJO, SJT, HSJ, HSJO				
60°C rating	35	63	60	108
75°C rating	50	90	65	117
90°C rating	65	117	80	144
105°C rating	80	144	95	171
3. Other types of insulated wires				
			See note e	
D. Electrical Insulation – General ^{f,o}				
1. Class C electrical insulation material				
2. Class (180) electrical insulation material				
3. Fiber used as electrical insulation or cord bushings	65	117	90	162
4. Phenolic composition used as electrical insulation or as parts where malfunction results in a risk of fire or electric shock	125	225	150	270
5. Thermoplastic material				
6. Varnished cloth insulation				
			25°C or 77°F less than its temperature rating	
E. Metals ^g				
1. Aluminum alloys –				
a. 1100 (2S)	183	330	239	430
b. 3003 (3S)	239	430	294	530
c. 2014, 2017, 2024, 5052 ^h	294	530	350	630

Table 10.1 Continued

Device or material	Column 1		Column 2	
	Degrees		Degrees	
	C	F	C	F
2. Aluminum-coated steel, heat-resistant type ^l	572	1030	708	1275
3. Carbon steel – Coated with Type A19 ceramic	572	1030	628	1130
4. Galvanized steel ^{j,3}	267	480	350	630
5. Low-carbon steel, cast iron ^{k,i}	461	830	517	930
6. Stainless steel –				
a. Type 302, 303, 304, 321, 347	686	1235	767	1380
b. Type 316	667	1200	748	1345
c. Type 309S	867	1560	950	1705
d. Types 310, 310B	894	1610	975	1755
e. Type 430	728	1310	808	1455
f. Type 446	961	1730	1042	1875
F. Handles ⁿ				
1. Metallic	50	122	–	–
2. Glass	78	172	–	–
3. Plastic ^m	85	185	–	–
4. Wood	150	302	–	–

^a The motor diameter is to be measured in the plane of the laminations of the circle circumscribing the stator frame, excluding lugs, and boxes, used solely for motor cooling, mounting, assembly, or connection.

^b Ordinarily, coil or winding temperatures are to be measured by thermocouples unless the coil is inaccessible for mounting of these devices (for example, a coil immersed in sealing compound) or unless the coil wrap includes thermal insulation or more than 2 layers, 1/32 inch (0.8 mm) maximum, of cotton, paper, or rayon. For a thermocouple-measured temperature of a coil of an alternating-current motor, having a diameter of 7 inches (178 mm) or less, the thermocouple is to be mounted on the integrally applied insulation on the conductor. At a point on the surface of a coil where the temperature is affected by an external source of heat, the temperature rise measured by a thermocouple shall exceed the indicated maximum by the amount noted below, when the temperature rise of the coil, as measured by the resistance method, is not more than that specified in the table.

- 5°C (9°F) for Class A insulation on coil windings of alternating-current motors having a diameter of 7 inches (178 mm) or less, open type.
- 10°C (18°F) for Class B insulation on coil windings of alternating-current motors having a diameter of 7 inches (178 mm) or less, open type.
- 15°C (27°F) for Class A insulation on coil windings of alternating-current motors having a diameter of more than 7 inches (178 mm), open type.
- 20°C (36°F) for Class B insulation on coil windings of alternating-current motors having a diameter of more than 7 inches (178 mm), open type.

^c For an electrolytic capacitor which is physically integral with or attached to a motor, the temperature rise on insulating material integral with the capacitor enclosure shall be not more than 65°C (117°F).

^d A capacitor which operates at a temperature higher than a 65°C (117°F) rise shall be judged on the basis of its marked temperature rating.

^e For standard insulated conductors other than those specified, reference shall be made to the National Electrical Code; the maximum temperature rise in any case is 25°C or 77°F less than the temperature rating of the insulation in question where Column 1 temperature rises are specified, and the maximum temperature rise where Column 2 rises are specified is to be based on the heat-resistant properties of the insulation. Column 2 temperature rises are 15°C (27°F) above Column 1.

Table 10.1 Continued

Device or material	Column 1		Column 2	
	Degrees		Degrees	
	C	F	C	F
<p>[†] The limitations on phenolic composition and on rubber and thermoplastic insulation do not apply to compounds which have been investigated and found to have special heat-resistant properties.</p> <p>^g The specified maximum temperature rises apply to parts whose malfunction shall result in the product to not be capable of use.</p> <p>^h These and other alloys containing more than 1 percent magnesium shall not be used when the reflectivity of the material is employed to reduce the risk of fire.</p> <p>ⁱ When the reflectivity of aluminum coated steel is employed to reduce the risk of fire, the maximum temperature rise is 830°F (461°C).</p> <p>^j The specified maximum temperature rises shall apply when the galvanizing is required as a protective coating or the reflectivity of the surface is employed to reduce the risk of fire.</p> <p>^k The specified maximum temperature rises shall not apply to parts of 0.152 inch (3.86 mm) thick or heavier steel and 3/16 inch (4.8 mm) thick or heavier cast iron employed for the hearth and to other parts of 0.093 inch (2.36 mm) thick or heavier steel, and 1/8 inch (3.2 mm) thick or heavier cast iron when:</p> <ol style="list-style-type: none"> 1. The part is not the only enclosure, and 2. Malfunction of the part shall not expose adjacent combustible construction to the fire in the fire chamber. <p>^l The specified maximum temperature rise shall not apply to parts of 1/4 inch (6.4 mm) thick or heavier steel and 5/16 inch (7.9 mm) thick or heavier cast iron.</p> <p>^m Includes plastic with a metal plating not more than 0.005 inch (0.13 mm) thick; and metal with a plastic or vinyl covering not less than 0.005 inch (0.13 mm) thick.</p> <p>ⁿ Handle temperatures are maximum temperatures, based on an ambient temperature of 70°F or 21°C.</p> <p>^o Maximum temperature rises are based on an ambient temperature of 25°C or 77°F.</p>				

Figure 10.3
Typical thermocouple locations (-) Back, side, and floor at fireplace (Zone A)

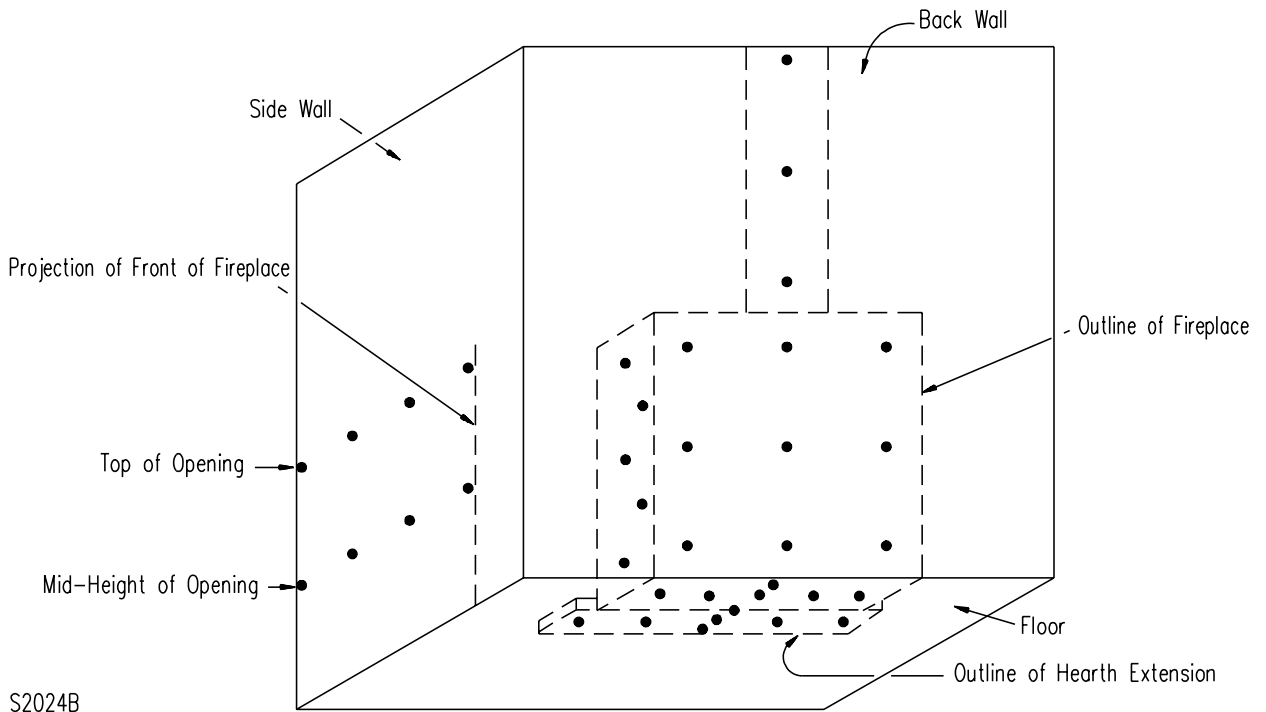

10.23 A minimum number of typical thermocouple locations to be attached to the wood surfaces of a chimney enclosure not installed with an attic is shown in Figure 10.4.

10.24 A minimum number of typical thermocouple locations to be attached to the wood surfaces of a chimney enclosure having an attic is shown in Figure 10.5.

10.25 A minimum number of typical locations of thermocouples to be attached to the wood surfaces of a tall chimney enclosure are shown in Figure 10.6.

Figure 10.4
Typical thermocouple locations for chimney enclosure without attic

Figure 10.4 revised January 26, 1998

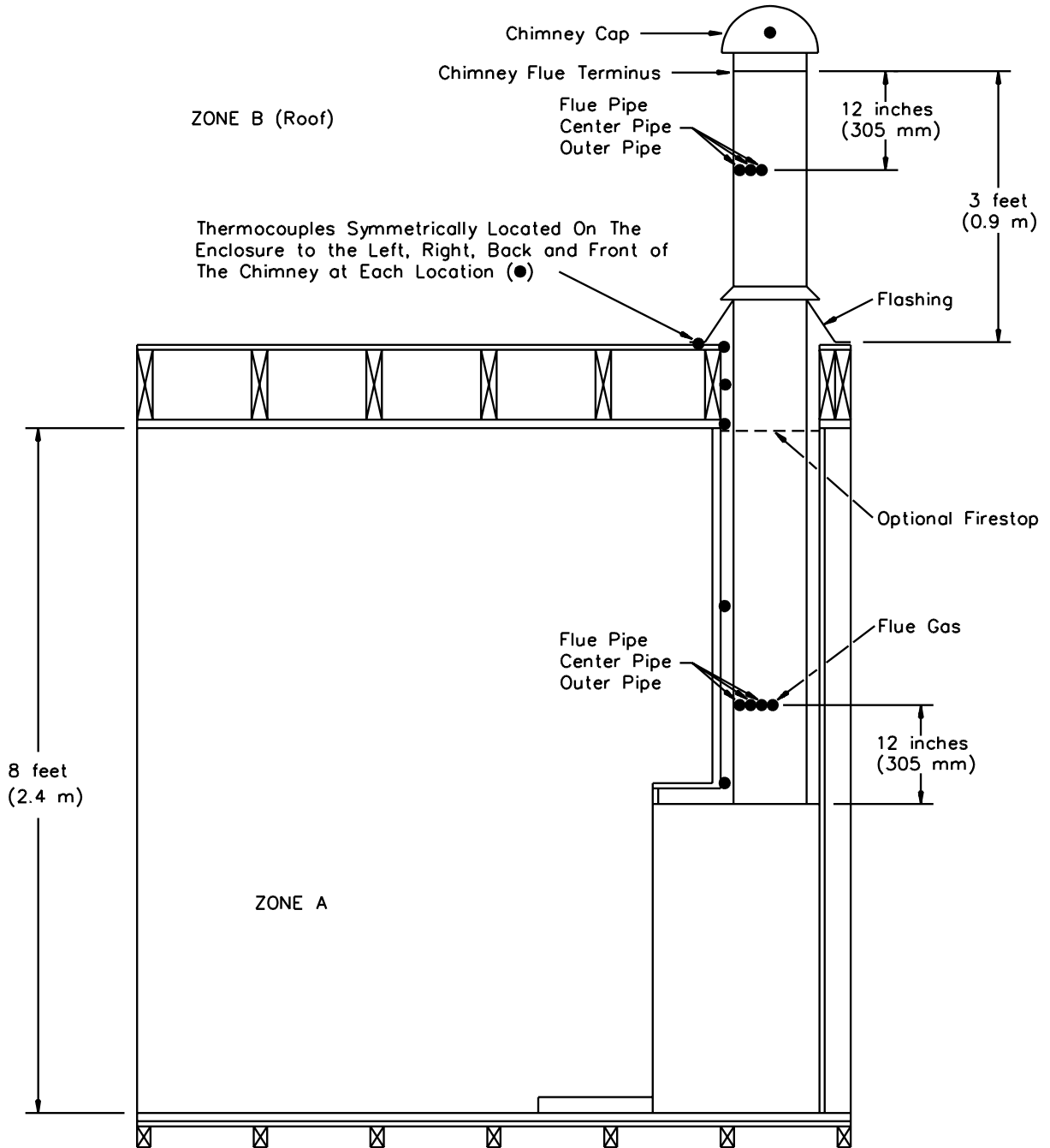

S2025

No Text on This Page

Figure 10.5
Typical thermocouple locations for chimney enclosure with attic

Figure 10.5 revised January 26, 1998

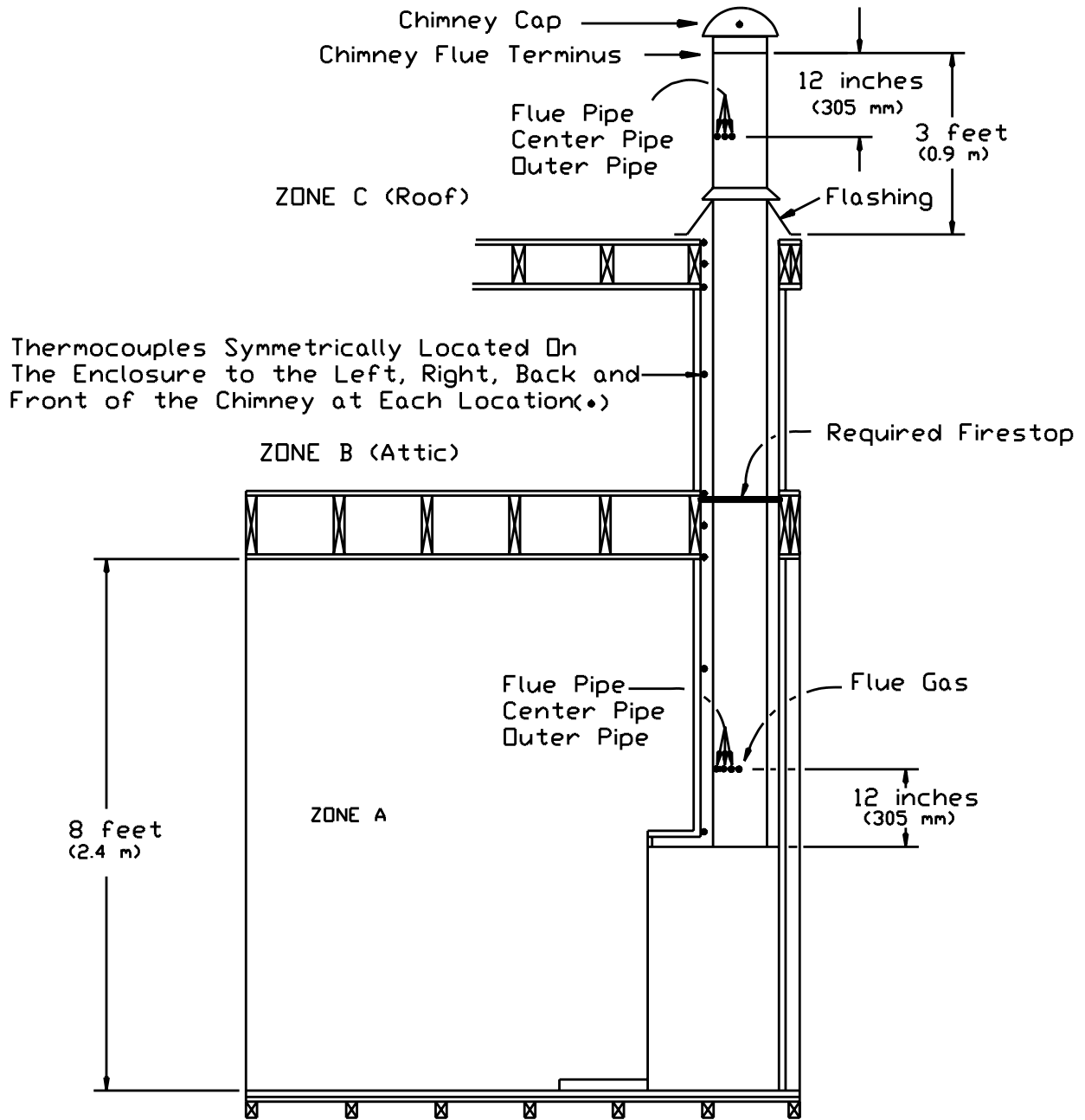

S2026

Figure 10.6
Typical thermocouple locations (Tall chimney height with firestops)

Figure 10.6 revised January 26, 1998

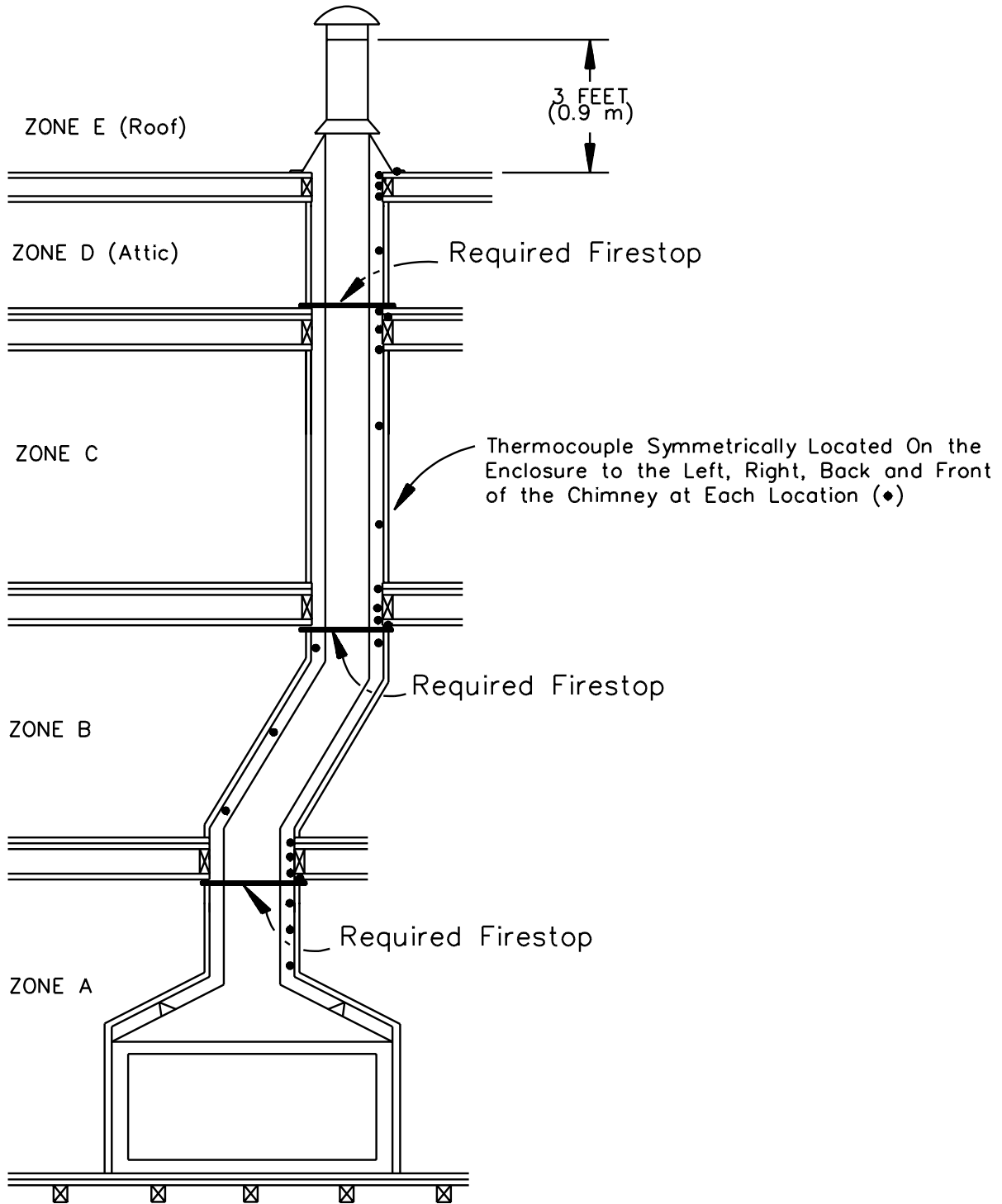

S2027

10.26 For test enclosure elements in contact with fire chamber or chimney parts, junctions of thermocouples are to be placed on the fire chamber or chimney part surfaces.

Exception No. 1: Where a point or line contact of a spacer to an enclosure is not greater than 1/8 inch (3.2 mm) diameter or width, thermocouples are to be placed on the test enclosure at points 1/2 inch (12.7 mm) from the center line of such point or line contact.

Exception No. 2: Thermocouples shall not be attached to a combustible floor unless the bottom of the fire chamber is in direct contact with the floor.

10.27 Thermocouples are to be attached to the plywood flooring under the fireplace and placed between the hearth extension material and the plywood flooring. The two front center thermocouples under the hearth extension shown in Figure 10.3 are to be placed 1/2 inch (12.7 mm) and 1-1/2 inches (38.1 mm), respectively, from the front edge of the hearth extension. The front edge of the hearth extension is the exposed front away from the face of the fireplace, and not the edge that abuts the front of the fireplace surround. See Figure 10.3.

10.28 Thermocouples are to be attached to the various surfaces of the fire chamber in at least the typical locations shown in Figures 10.7 and 10.8.

10.29 Thermocouples are to be attached to the chimney surfaces as shown in Figures 10.4 and 10.5.

10.30 Thermocouples are to be attached to the air duct portions of circulating air type fireplaces as shown in Figure 10.9. One thermocouple is to be attached on the top of each elbow, and one thermocouple is to be attached on the face of each grille.

10.31 The outlet-air temperature of a circulating air type fireplace is to be determined by use of parallel connected bead-type thermocouples, having wire not larger than No. 24 AWG (0.21 mm²), and located 1 inch (25.4 mm) from the outer face of the warm air grille or register.

10.32 The thermocouples are to be arranged and supported in a rectangular shield as illustrated in Figure 10.10. The length of the shield is to correspond to the width of the warm-air outlet opening.

10.33 With reference to the requirement of 10.31, the thermocouple assembly is to be moved vertically over the face of the outlet opening to determine the maximum indicated temperature.

10.34 The surface temperature for the largest amount of material employed in a handle or knob used on a fireplace shall not exceed the temperature specified in Table 10.1 during the Radiant Fire Test and Brand Fire Test.

Exception: The temperature limitation does not apply to knobs used for adjusting combustion air inlets.

Figure 10.7
Typical thermocouple locations (Fire chamber surfaces)

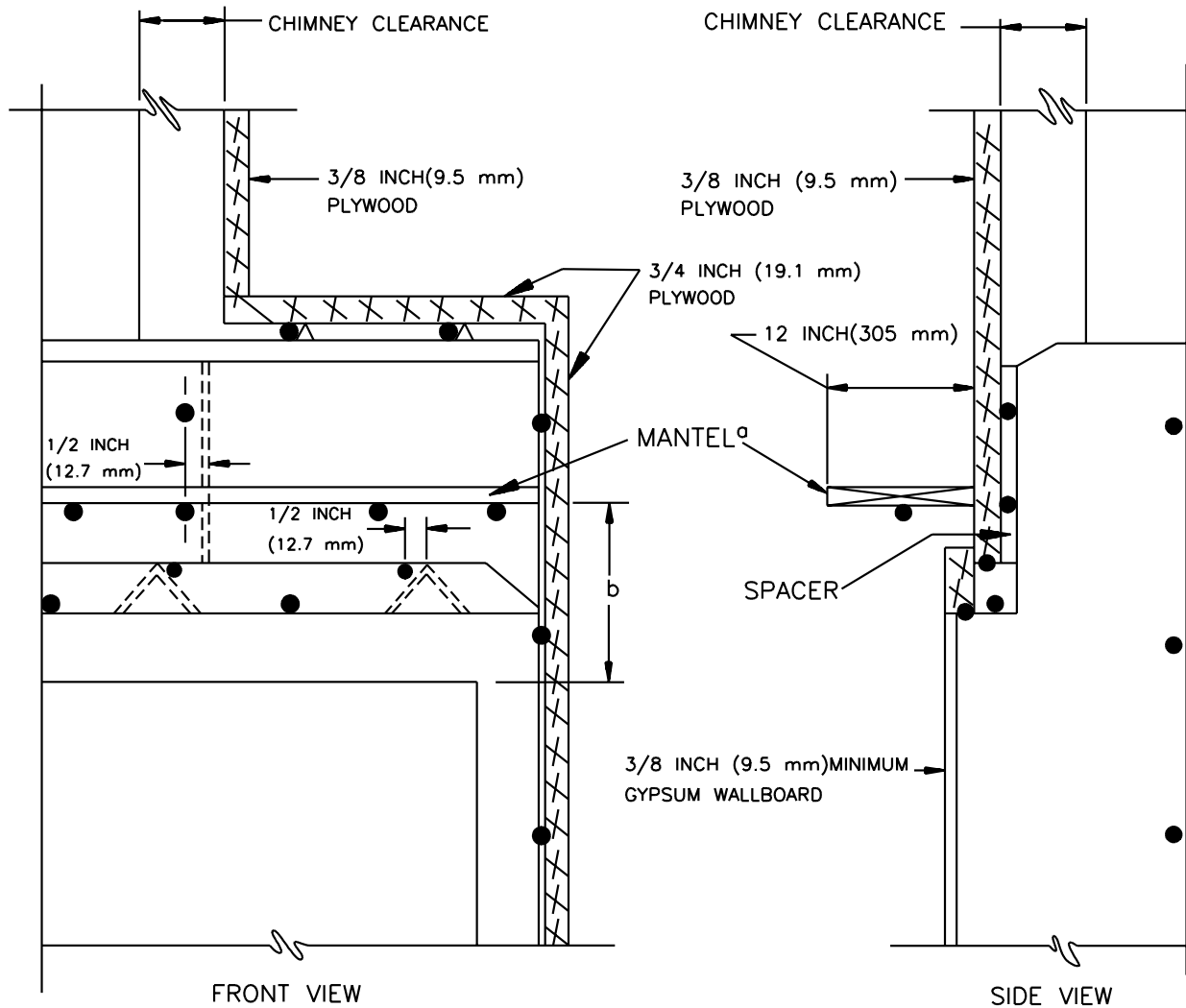

S2028A

a. Mantel is used only when fireplace is intended for use with a mantel.

b. Minimum distance above fireplace opening specified in installation instructions. Thermocouples not required when mantel is at least 12 inches (305 mm) above fireplace opening.

Figure 10.8
Typical thermocouple locations (Fire chamber assembly)

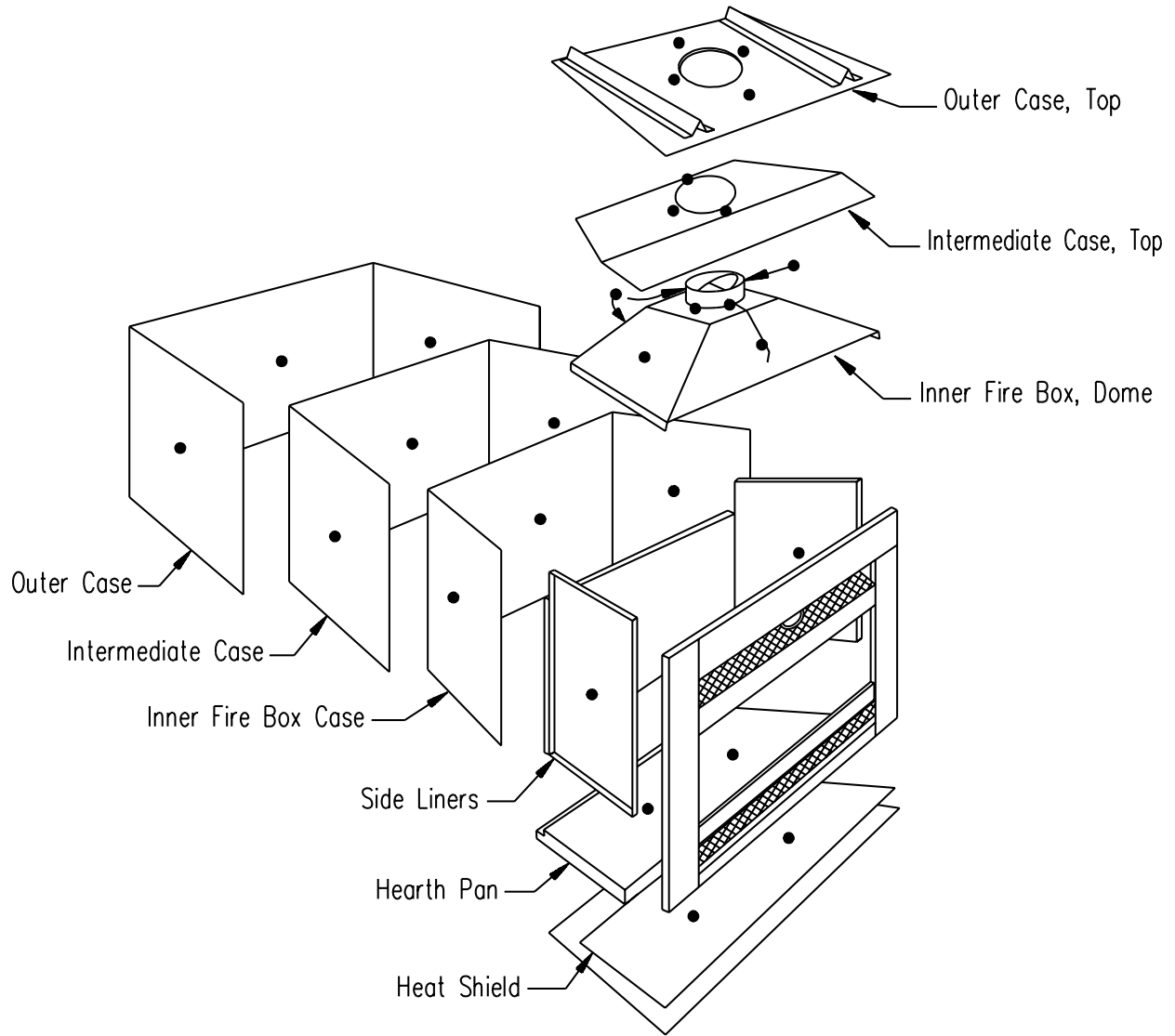

Note: Thermocouples to be installed on the material surface away from the fire

S2029

Figure 10.9
Typical thermocouple locations (Air duct fittings)

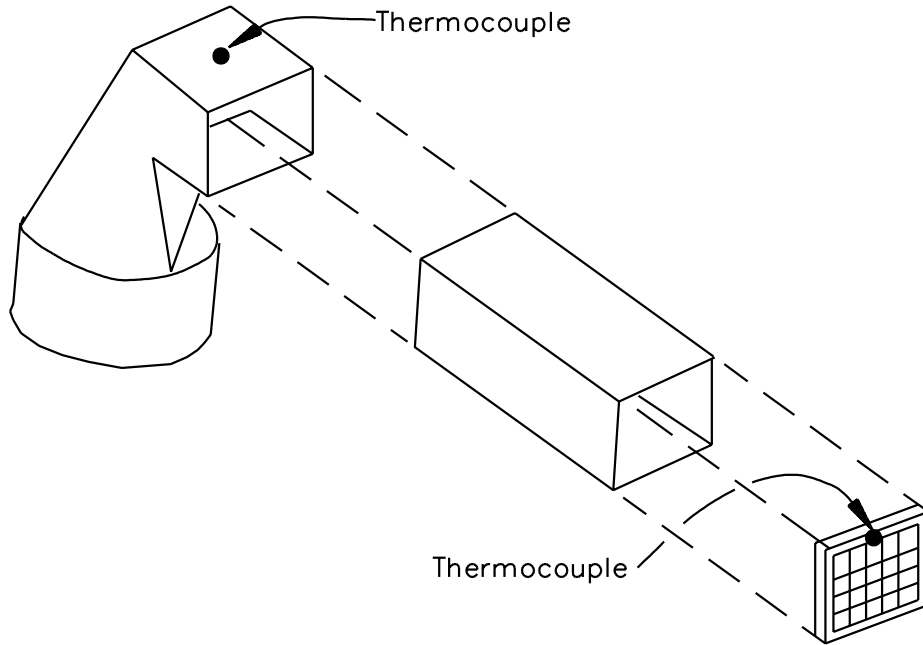

S2030

Figure 10.10
Thermocouple arrangement for outlet air temperature

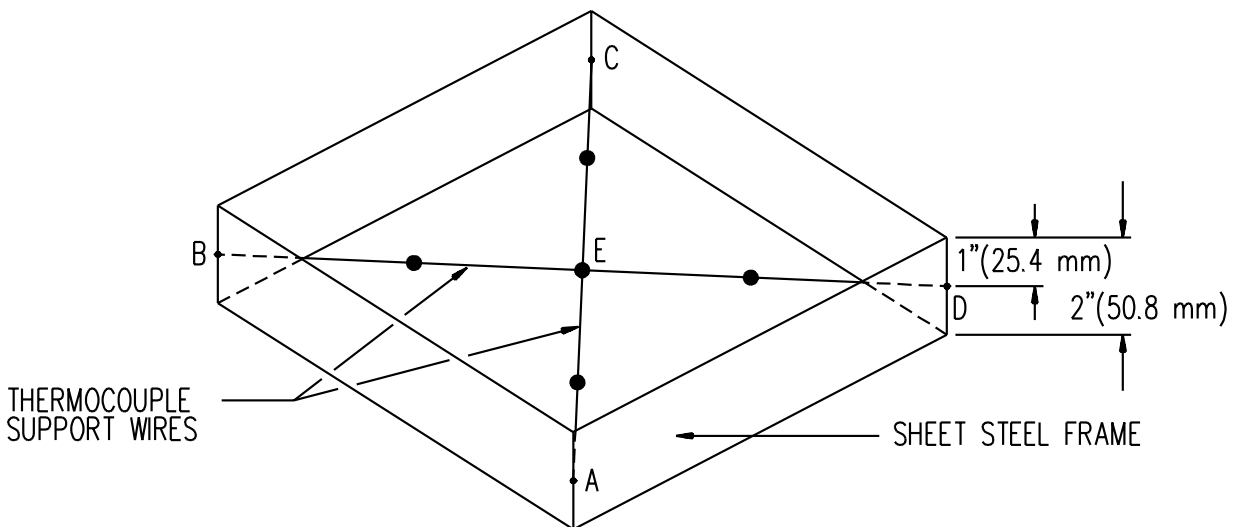

- Thermocouples, No. 18 to 24 AWG (0.82 to 0.21 mm). One each located 2/3 of distance from point E to points A, B, C and D, and one at point E.

S2031

11 Preconditioning Tests

11.1 General

11.1.1 Prior to any Performance Tests, the fireplace is to be subjected to the Thermal Shock Test and either the Temperature Test – 1700°F Flue Gases or Temperature Test – 2100°F Flue Gases.

Exception: In lieu of the Thermal Shock Test and the Temperature Test – 1700°F Flue Gases or Temperature Test – 2100°F Flue Gases, the fireplace shall not be preconditioned as described in 11.1.2, unless:

- a) The chimney complies with the Standard for Factory-Built Chimneys for Residential Type and Building Heating Appliance, UL 103; or*
- b) The chimney has previously been investigated and found capable of being used for the intended fireplace application.*

11.1.2 When the Thermal Shock Test and the Temperature Test – 1700°F Flue Gases or Temperature Test – 2100°F Flue Gases are not conducted (see 11.1.1), the fireplace is to be subjected to a preliminary wood firing that produces a nominal flue-gas temperature of 1000°F (538°C) for 5 hours. The temperature is to be measured by a thermocouple as described in Figure 10.1 at a point 12 inches (305 mm) vertically above the inlet of the chimney as shown in Figure 10.4 or 10.5.

11.2 Thermal shock test

11.2.1 A gas-fired flue-gas generator as illustrated by Figure 11.1 is to be used to supply flue gases to the inlet of the chimney being tested. The generator shall produce flue gases at the specified test temperatures when fired at the test inputs specified hereafter.

11.2.2 The flue-gas generator outlet is to be connected directly to the inlet of the chimney to be tested by means of an uninsulated flue pipe having a diameter equal to that of the chimney inlet and the front of the fireplace opening is to be closed as shown in Figure 11.2.

Figure 11.1
Flue-gas generator

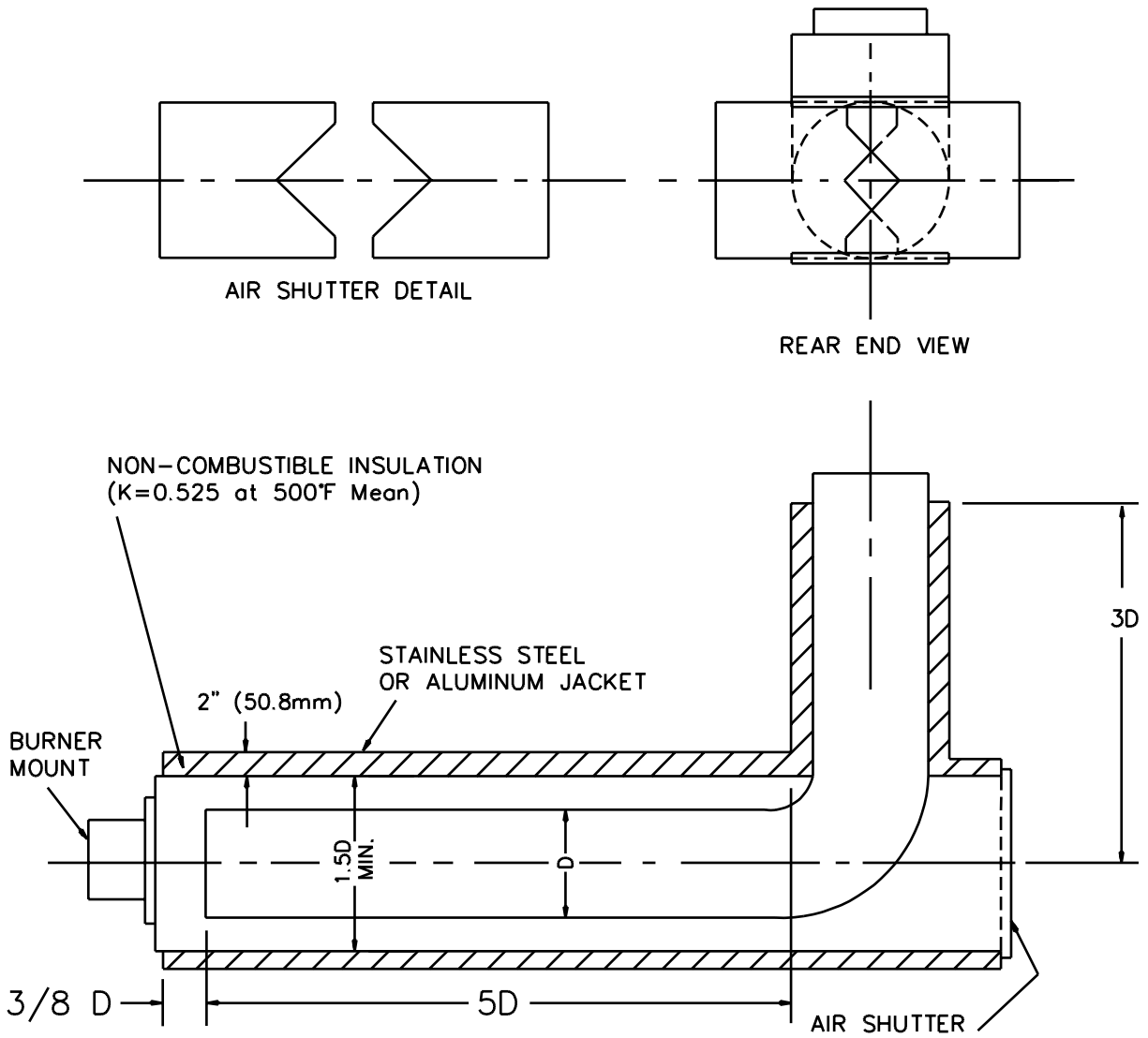

S2034

Figure 11.2

Flue gas generator application for temperature test – 1700°F flue gases

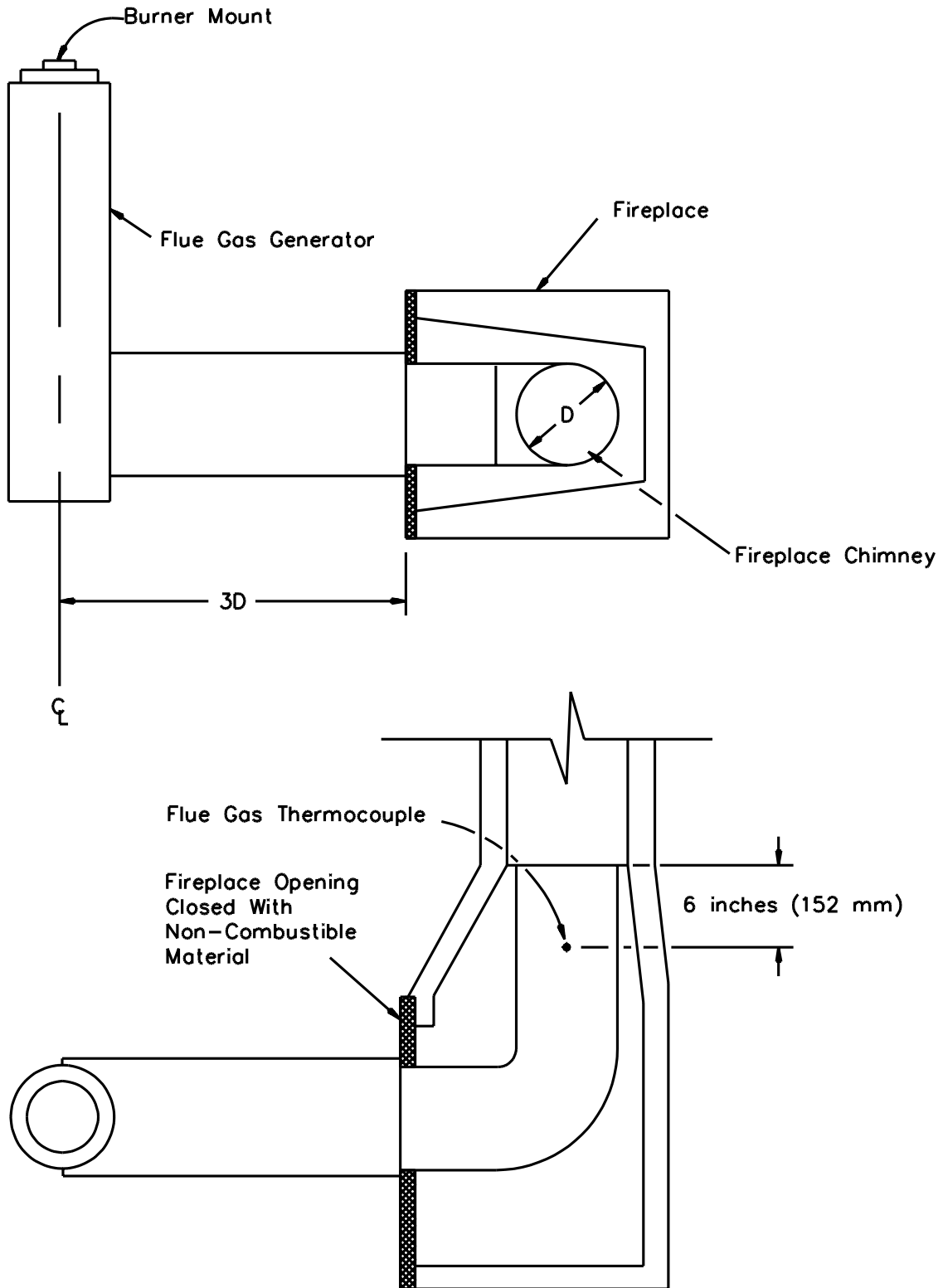

S2032

11.2.3 The test is to be started with the test chimney and the test structure at room temperature. The flue-gas generator is to be fired to at least the input specified in Column 1 of Table 11.1 and regulated to produce flue gases at a temperature of 1630°F (906°C) above room temperature at the flue-gas thermocouple location shown in Figure 11.2. The test is to be continued for a period of 10 minutes, at which time the burner is to be shut off.

Table 11.1
Flue-gas generator inputs

Equivalent nominal diameter of chimney		Minimum input to flue-gas generator BTU per hour (kW)					
		Column 1		Column 2		Column 3	
Inches	mm	Temperature test – 1700°F (927°C) flue gases		Temperature test – 1000°F (538°C) flue gases		Temperature test – 2100°F (1125°C) flue gases	
6	150	97,000	(28.4)	48,500	(14.2)	175,000	(51.2)
7	180	131,600	(38.6)	65,800	(19.3)	237,000	(69.4)
8	200	172,400	(50.5)	86,200	(25.3)	310,000	(91.0)
9	230	218,000	(63.9)	109,000	(31.9)	392,000	(115.0)
10	250	270,000	(79.1)	135,000	(39.6)	486,000	(142.4)
11	275	330,000	(96.7)	165,000	(48.4)	592,500	(173.6)
12	300	390,000	(114.0)	195,000	(57.2)	699,000	(205.0)

11.2.4 This test is to be conducted three times, and at the start of the first test the chimney is to be at room temperature. At the end of each test the chimney is to be cooled to room temperature or to cool for 4 hours, whichever occurs first, before the next trial.

11.2.5 No temperature readings other than flue-gas temperature is required to be recorded for the tests described in 11.2.4.

11.3 Temperature test – 1700°F flue gases

11.3.1 The test is to be conducted using the same apparatus as designated for the Thermal Shock Test and is to be started with the test chimney and the test structure at room temperature.

11.3.2 The test conditions then are to be established using at least the gas input shown in Column 2 of Table 11.1. Input is to be maintained to produce flue gas at a temperature of 930°F (517°C) above room temperature at the location designated in Figure 11.2 and operation is to be continued until equilibrium temperatures are attained on surfaces of chimney parts and the test structure.

11.3.3 After equilibrium temperatures are attained as described in 11.3.2, the input to the flue-gas generator is to be increased to that given in Column 1 of Table 11.1, and regulated to produce a temperature of 1630°F (906°C) above room temperature at the location designated in Figure 11.2 and the test continued for 10 minutes, at which time the burner is to be shut off.

11.3.4 The maximum temperature attained on the test structure (ceilings, enclosures, floors, and joists) and on surfaces of the chimney assembly at points of zero clearance to the test structure shall be not more than 175°F (97°C) above room temperature while the flue-gas temperature is maintained as described in 11.3.3 and after the flue-gas generator is shut off.

11.4 Temperature test – 2100°F flue gases

11.4.1 The test is to be conducted using the same apparatus as designated for the Thermal Shock Test and is to be started with the test chimney and the test structure at room temperature. Fireplaces using Type HT chimneys complying with the requirements specified in the Standard for Factory-Built Chimneys for Residential Type and Building Heating Appliances, UL 103, are identified as complying with the requirements for the 2100°F (1135°C) test.

11.4.2 The test conditions then are to be established at the inputs shown in Column 2 of Table 11.1, and maintained to produce flue gas at a temperature of 930°F (517°C) above room temperature as measured by means of a flue-gas thermocouple located centrally in the flue-gas stream as shown in Figure 11.3. The operation is to be continued until equilibrium temperatures are attained on surfaces of fireplace parts and the test structure.

11.4.3 After equilibrium temperatures are attained under the test conditions described in 11.4.2, the input to the flue-gas generator is to be increased to that specified in Column 3 of Table 11.1 and regulated to produce a temperature of 2030°F (1128°C) above room temperature at the location designated in Figure 11.3. The test period shall be 10 minutes, exclusive of the time taken to reach the 2030°F temperature rise above room temperature (which shall not exceed 15 minutes). At the end of the test period the flue-gas generator is to be shut off.

11.4.4 The test specified in 11.4.3 is to be conducted three times. The tests are to be conducted with the full length of the connector pipe insulated with a 3-inch (75-mm) thick layer of ceramic blanket insulation or equivalent insulation having a K factor of 1.7 at 2000°F (1079°C).

11.4.5 The maximum temperature attained on the test structure (enclosures and joists) and on surfaces of the fireplace assembly at points of zero clearance to the test structure shall be not more than 175°F (97°C) above room temperature while the flue-gas temperature is maintained as described in 11.4.3 and after the flue-gas generator is shut off.

Figure 11.3
Flue gas generator application for temperature test – 2100°F flue gases

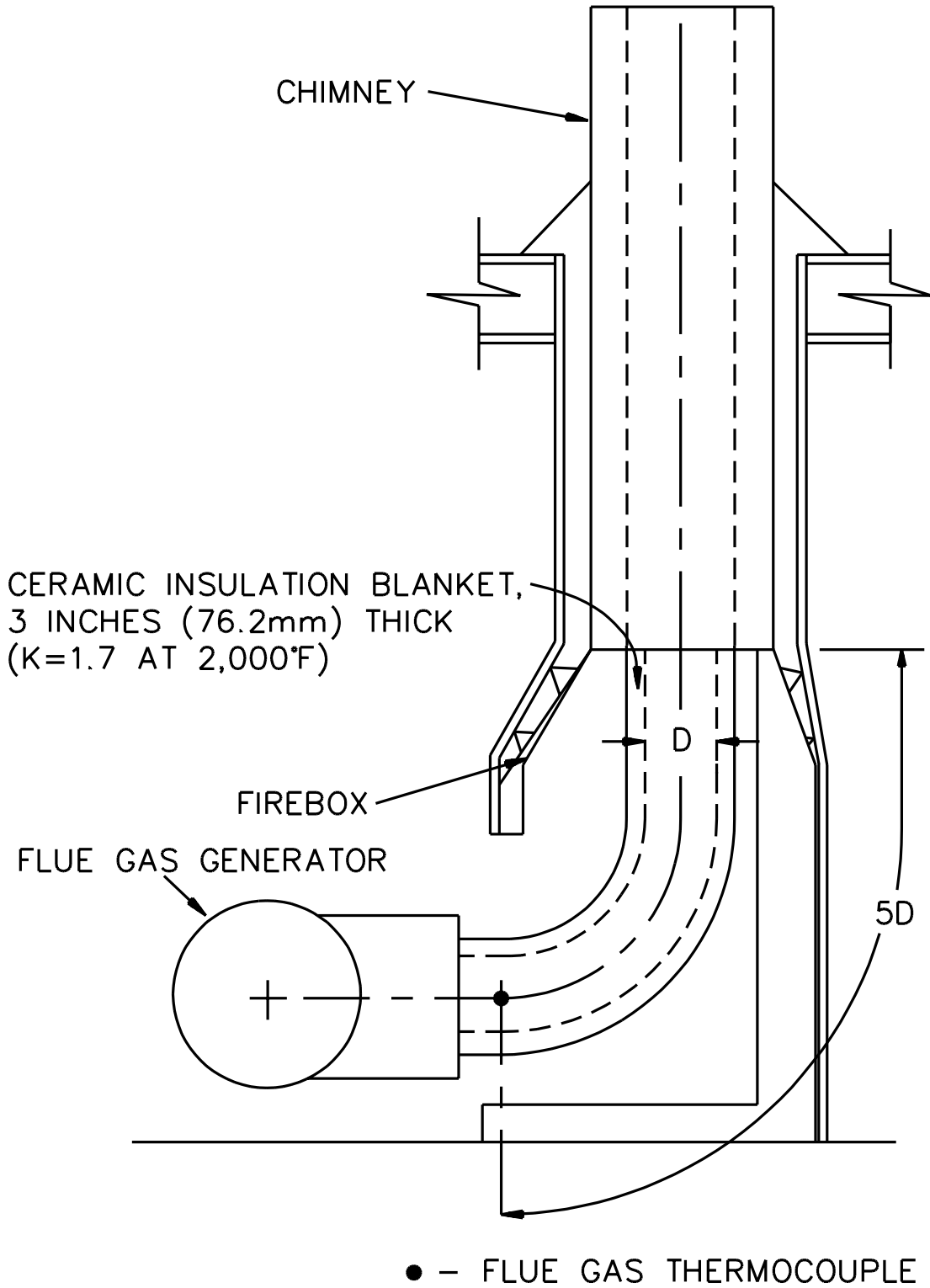

S3199

12 Radiant Fire Test

12.1 A basket grate is to be constructed of 3/8 inch (9.5 mm) square steel bar stock spaced 1 inch (25.4 mm) apart on centers as illustrated in Figure 12.1. The basket is to be open at the back for placement against the back of the hearth. Figure 12.2 shows alternate grate configurations that shall be used to accommodate two typical shapes of hearths.

12.2 For a fireplace whose hearth incorporates raised ledges the basket grate is to have an inside area in the plan view equal to two-thirds of the total hearth area. See 12.4.

12.3 For a fireplace whose hearth incorporates an integral grate that is sized one-half the hearth area or larger, the basket grate is to have an inside area in the plan view equivalent to the effective burning area of the integral grate. For a fireplace whose hearth incorporates an integral grate that is sized less than one-half the hearth area, the basket grate is to have an area equivalent to one-half the hearth area. See 12.4.

12.4 For the basket grate referenced in 12.2 and 12.3, in the plan view, the shape of the basket grate is to conform closely to the shape of the hearth. When the grate is placed in position, the distance from the front inside edge of the grate to the front of the hearth is to be one-sixth of the maximum hearth depth as measured between the front and back edges of the hearth. The inside depth of the basket grate is to be 6 inches (152 mm) and the grate is to stand on legs that support the inside bottom of the grate 4 inches (102 mm) above the hearth. See Figure 12.2.

12.5 The basket grate is to be loaded to a depth of 6 inches (152 mm) with charcoal briquettes formed in the shape of 2.0- by 1.9-inch (50- by 48-mm) square pillows, each having rounded edges and a maximum thickness of 1.2 inches (30 mm). The briquettes are to have a count weight of 17 per pound (38 kg), a heat content (dry basis) of 11,500 Btu per pound (26,750 J/g), and a moisture content of 5 percent.^a

^a A briquette that is capable of being used for this test is manufactured by the Kingsford Chemical Company, Oakland, California 94623.

12.6 A damper intended to be adjustable between open and closed positions is to be regulated to produce severe conditions, and is not to be closed to the extent that flue gases spill into the living space.

Figure 12.1
General form of charcoal basket

Figure 12.1 revised January 26, 1998

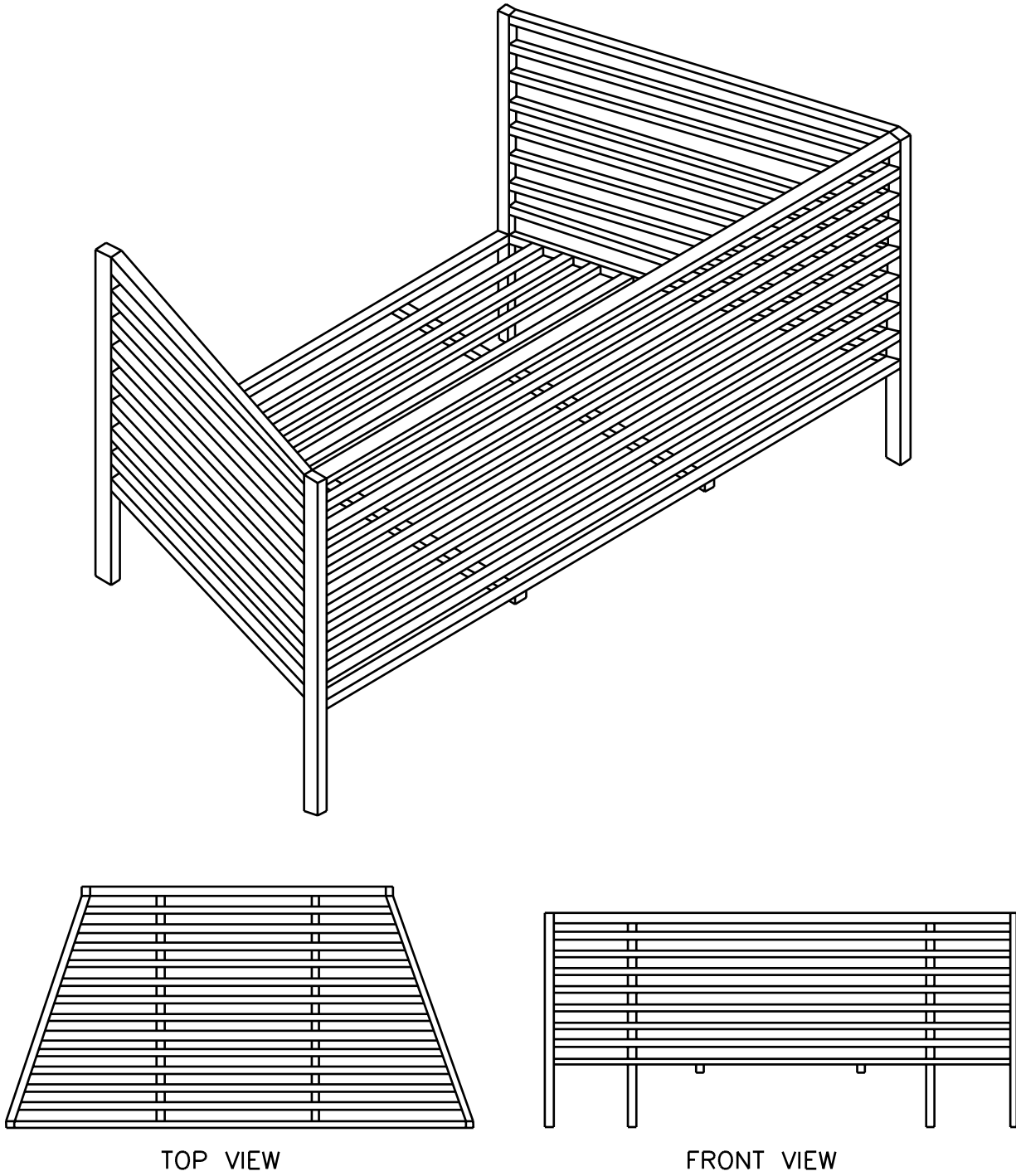

S 2416

Figure 12.2
Typical relation of grate to hearth

Figure 12.2 revised January 26, 1998

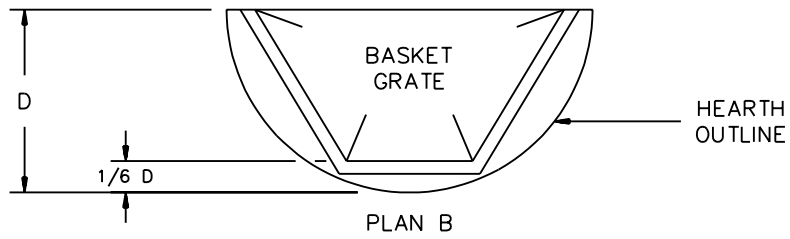
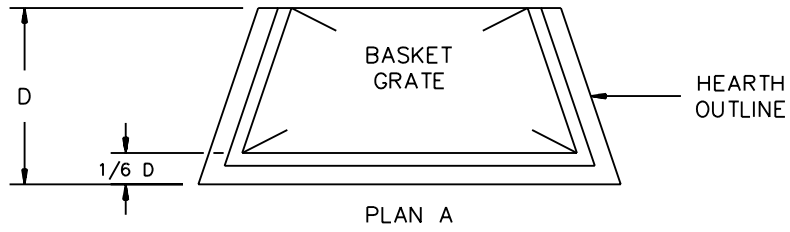

S2417

No Text on This Page

12.7 After ignition, fuel is to be added at 7-1/2 minute intervals and at each interval the fire is to be poked or stirred in an effort to maintain a 6 inch (152 mm) bed of fuel burning at maximum intensity. Poking and stirring are to be accomplished by inserting a flat bar of steel at the midpoint of the basket at one end and sliding it through the fire bed, and then inserting the bar at the bottom of the basket at the other end and sliding it the opposite way through the fire bed. Ashes on the hearth are to be removed prior to each addition of fuel.

12.8 Temperatures at all points of measurement are to be recorded at intervals not exceeding 30 minutes until it is apparent the maximum temperatures have been attained. Maximum temperatures are identified to have been attained when three successive readings taken at 30-minute intervals show no change or show a decrease.

12.9 When the fireplace is fired as described in 12.5 – 12.7, the maximum temperature rise above ambient zone temperature shall not exceed:

- a) 117°F (65°C) on exposed surfaces of the test enclosure and
- b) 90°F (50°C) on concealed surfaces of the test enclosure, such as beneath the hearth (fire chamber), beneath the hearth extension, behind the wall-mounted shields, within the chimney enclosure and surrounding the fire chamber.

12.10 The temperature rise of any part of the fireplace and chimney shall not exceed the maximum values specified in Column 1 of Table 10.1 for the material employed.

12.11 The temperature rise of the outlet air at the outlet in an air duct system shall not exceed 250°F (139°C) above room ambient temperature.

12.12 The temperature rise of the surface grille of remote air outlets located in areas other than directly in front of and above the fire chamber opening shall not exceed:

- a) 140°F (78°C) above ambient zone temperature for grilles located 36 inches (914 mm) or less above the floor.
- b) 180°F (100°C) above ambient zone temperature for grilles located more than 36 inches (914 mm) above the floor.

13 Brand Fire Test

13.1 Andirons to be used in this test are to be constructed as illustrated in Figure 13.1.

Exception: This requirement does not apply when integral grates are provided.

13.2 The brands are to be constructed as illustrated in Figure 13.2, and are to employ strips of dry (moisture content of 19 percent or less) Douglas fir finished to 3/4 by 3/4 inch (19.1 by 19.1 mm), weighing 0.02 ± 0.002 pounds per cubic inch (554.0 ± 55.4 kg/m³) and spaced 1 inch (25.4 mm) apart on centers. The brands are to be conditioned in an oven at 105 – 150°F (40.5 – 66°C) for at least 16 hours prior to being burned. Conditioned brands are to be used within 3 hours after their removal from the oven.

13.3 The brands are to be placed in the hearth area as illustrated in Figure 13.3 which shows two typical hearth shapes. Each front and rear brand is to have an area in the plan view equal to one-third of the total hearth area. When the brands are located as illustrated in Figure 13.3, the distance from the front edge of the front brand to the front of the hearth is to be one-sixth of the maximum hearth depth measured between the front and back edges of the hearth.

**Figure 13.1
Andiron**

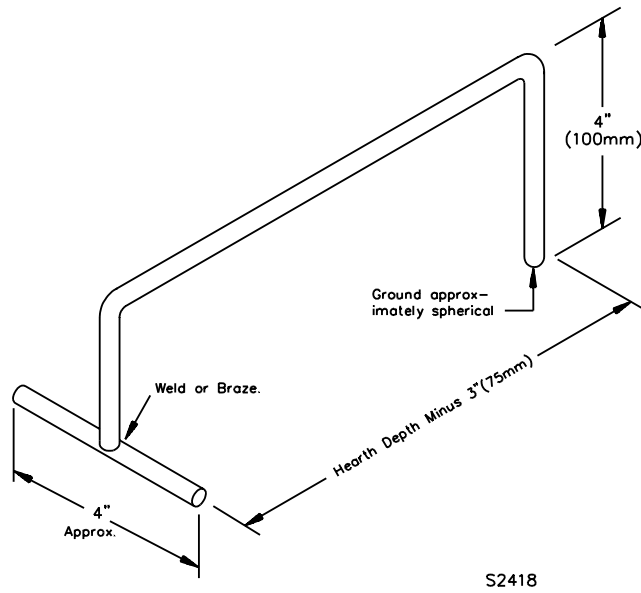

Material: 5/8 inch (15.9 mm) round or square steel bar stock. Two each required.

**Figure 13.2
Brands**

Figure 13.2 revised January 26, 1998

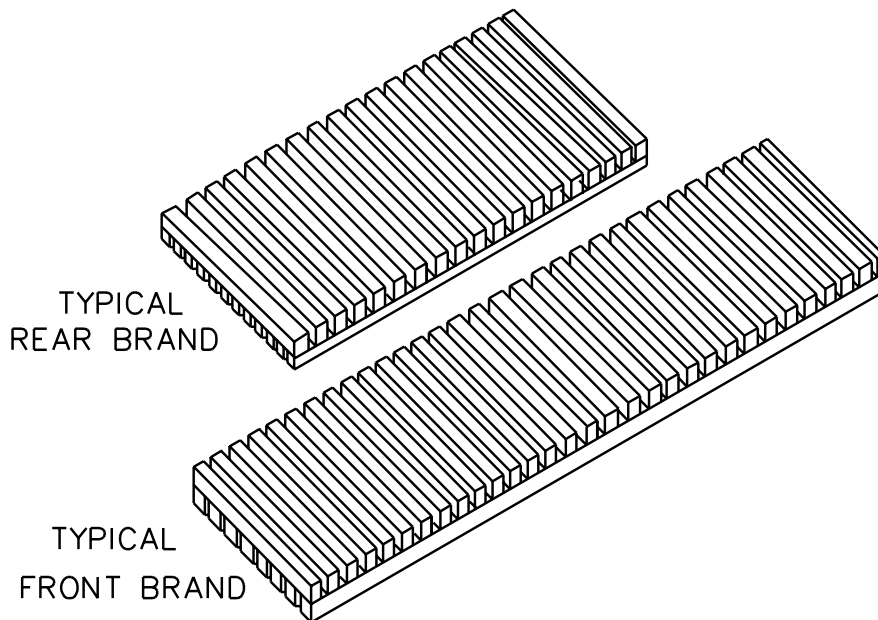

S2419

Figure 13.3
Typical relation of brands to hearth

Figure 13.3 revised January 26, 1998

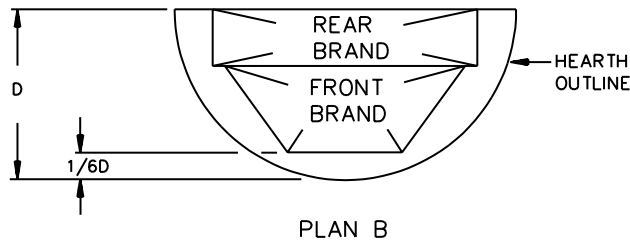
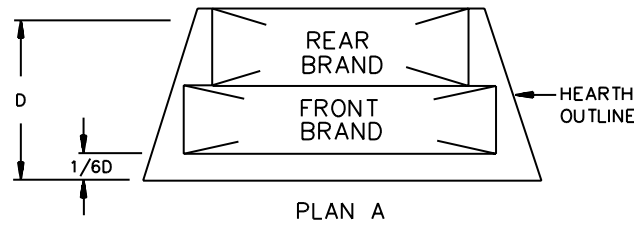

S2420A

13.4 The hearth area is identified to be the effective area on which the fuel is to be burned, and consists of the area bordered by the back and side walls of the fireplace, and the plane of the front opening of the fireplace.

Exception No. 1: For a fireplace incorporating raised ledges, the hearth area is to be defined as specified in 13.5.

Exception No. 2: For a fireplace incorporating an integral grate, the hearth area is to be defined as specified in 13.6.

13.5 For a fireplace whose hearth area incorporates raised ledges, each brand is to have an area in the plan view equal to one-third of the hearth area as defined by the ledges. For the purpose of defining the hearth depth, the minimum ledge height above the hearth is to be identified as 1-1/2 inches (38.1 mm) at the front, and 6 inches (152 mm) at the sides and back and the maximum depth of the front ledge (regardless of actual depth) is identified not to exceed one-sixth of the depth of the hearth measured between the back wall of the fire chamber and the plane of the front opening (plane of door when used) of the fireplace.

13.6 When the fuel burning area is defined by the front of a log retainer with a minimum height of 4 inches (102 mm) and the sides and rear of the fireplace, each brand is to be one-half of the effective burning area of the hearth. When the fuel burning area is defined by an integral grate having a front with a minimum height of 4 inches (102 mm) and the sides and rear of the grate are a minimum of 6 inches (152 mm)

high, each brand is to be one-half of the area of the integral grate. When the effective burning area of the integral grate is less than one-half the hearth area of the fireplace, each brand is to have an area equivalent to one-half of the hearth area of the fireplace.

13.6 revised January 13, 1999

13.7 A damper constructed to be adjustable between open and closed positions is to be regulated to produce severe conditions and is not to be closed to the extent that flue gases spill into the living space.

13.8 Throughout the test there shall be no evidence of spillage of products of combustion or flame from the fireplace. Intermittent or sporadic wisps of smoke (smoking not longer than 15 seconds at a time) is not to be regarded as spillage.

13.9 After ignition, one brand is to be added every 7-1/2 minutes, alternating front and rear, with the long strips placed downward and parallel to the face of the fire chamber opening. Embers are to be leveled; ashes are not to be removed from the hearth.

Exception No. 1: A slower feed rate is to be used when greater temperature rises are produced.

Exception No. 2: When embers build up to a level of one-half of the fire chamber opening height, a slower feed rate is to be used to maintain a fuel bed that does not exceed this height.

13.10 Temperatures at all points of measurement are to be recorded at intervals not exceeding 30 minutes until it is apparent that maximum temperatures have been attained. Maximum temperatures are identified to have been attained when three successive readings taken at 30-minute intervals show no change or show a decrease.

13.11 When the fireplace is fired as described in 13.2 – 13.9, the maximum temperature rise above ambient zone temperature shall not exceed:

- a) 117°F (65°C) on exposed surfaces of the test enclosure; and
- b) 90°F (50°C) on concealed surfaces of the test enclosure, such as beneath the hearth (fire chamber), beneath the hearth extension, behind the wall-mounted shields, within the chimney enclosure and surrounding the fire chamber.

13.12 The temperature rise of any part of the fireplace and chimney shall not exceed the maximum specified in Column 1 of Table 10.1 for the material employed.

13.13 The temperature rise of the outlet air at the outlet in an air duct system of a circulating warm-air ducted fireplace shall not exceed 250°F (139°C) above ambient zone temperature.

13.14 The temperature rise of the surface grille of remote air outlets located in areas other than directly in front of and above the fire chamber opening shall not exceed:

- a) 140°F (78°C) above ambient zone temperature for grilles located 36 inches (914 mm) or less above the floor.
- b) 180°F (100°C) above ambient zone temperature for grilles located more than 36 inches (914 mm) above the floor.

14 Flash Fire Test

14.1 This test is to be conducted as a continuation of the Brand Fire Test, Section 13. The embers remaining from the Brand Fire Test are to be removed to a plane level with the top of the andirons.

14.2 Eight brands are to be stacked on the andirons, four in front and four in the rear, with the long strips placed downward. Each stack of four brands are tied together with wire not larger than No. 18 AWG (0.04 inch diameter).

14.3 The flue-gas outlet damper is to be fully opened.

14.4 During the resultant fire, there shall be no evidence of spillage of products of combustion, or flame from the fireplace. Intermittent or sporadic wisps of smoke (smoking not longer than 15 seconds at a time) is not to be regarded as spillage.

14.5 Temperatures at all points of measurement are to be recorded at intervals not exceeding 5 minutes until it is apparent that the maximum temperatures have been attained.

14.6 When the fireplace is fired as described in 14.1 – 14.4, the maximum temperature rises shall not exceed 140°F (78°C) above ambient zone temperature on the following surfaces:

- a) Test enclosure;
- b) Fireplace, or chimney parts at points of zero clearance to the test structure; and
- c) Beneath a hearth extension installed on the area specified for such an extension.

14.7 The temperature rise of any part of the fireplace and chimney shall not exceed the maximum value specified in Column 2 of Table 10.1 for the material employed.

14.8 The temperature rise of the surface grille of the air outlet is not to be recorded during this test.

14A Optional Unvented Decorative Log Temperature Test

14A.1 This test shall be conducted upon completion of the Brand Fire Test, Section 13, and the Flash Fire Test, Section 14.

Added 14A.1 effective May 17, 1999

14A.2 Unvented decorative log sets of the single and double burner type that comply with the Standard for Unvented Room Heaters, ANSI/IAS/AGA Z21.11.2, are to be installed into the hearth of the previously investigated factory-built fireplace in accordance with the manufacturer's instructions. The unvented log set is to be of the largest size which fits into the hearth of the fireplace and is to employ an input rating of 40,000 Btu/h while fired with either natural or propane gas.

Added 14A.2 effective May 17, 1999

14A.3 The unvented log sets are to be fired with the flue-gas outlet damper of the factory-built fireplace fully closed, the screen mesh doors drawn closed, and the fireplace glass doors (when provided) fully open. The chimney system is to remain installed on the fireplace during these tests.

Added 14A.3 effective May 17, 1999

14A.4 The installation and operation of the unvented log sets are to be conducted in accordance with the log manufacturer's installation and operating instructions.

Added 14A.4 effective May 17, 1999

UL Copyright Material

Not Authorized for Further Reproduction or Distribution without Permission from UL

14A.5 The temperatures at all points of measurement are to be recorded at intervals not exceeding 30 minutes until it is apparent the maximum temperatures have been attained. Maximum temperatures are considered to have been attained when three successive readings taken at 30-minute intervals show no change or show a decrease.

Added 14A.5 effective May 17, 1999

14A.6 When the unvented log sets are fired as described in 14A.2 and 14A.3, the maximum temperature rise above ambient zone temperatures shall not exceed the temperature limits required by 13.11.

Added 14A.6 effective May 17, 1999

15 Support Test

15.1 Parts of the fireplace shall not be damaged or become distorted, nor shall the security of their attachment to a building structure be impaired, when tested as described in 15.2 and 15.3.

15.2 Parts of the fireplace required to support the chimney, hood, or other part above the fireplace opening are to be installed as described in the manufacturer's instructions, in a framework simulating a typical installation. A section of the chimney, hood, or other part is to be placed on the fireplace as intended and is to be loaded either by means of weights or by a machine.

15.3 The maximum static load applied is to be equal to four times the load imposed by the heaviest chimney or by any other part that the fireplace is required to sustain in service. The load is to be applied for a minimum of 60 minutes.

16 Fire Chamber Strength Test

16.1 The fireplace, its hearth, and any factory-installed hearth extension are to be positioned and supported as intended with relation to a building structure. An inclined plane and a simulated log are to be prepared for use in this test. See Figures 16.1 and 16.2.

16.2 The inclined plane is to be positioned with respect to the fireplace as illustrated in Figures 16.3 and 16.4. The andirons shown in Figures 16.3 and 16.4 are to be as illustrated in Figure 13.1.

Figure 16.1
Inclined plane for strength test

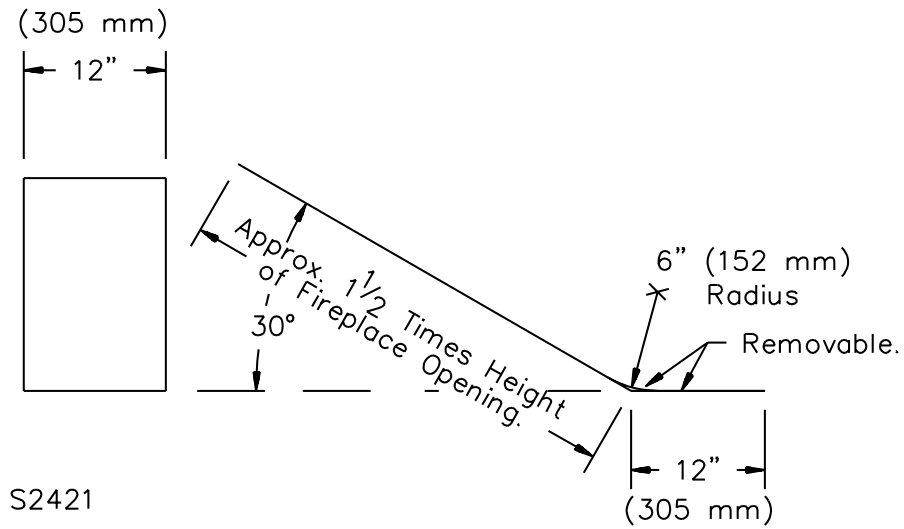

Material: Hardboard or other smooth surfaced material – sheet metal formed to radius as shown.

Support: As convenient.

No Text on This Page

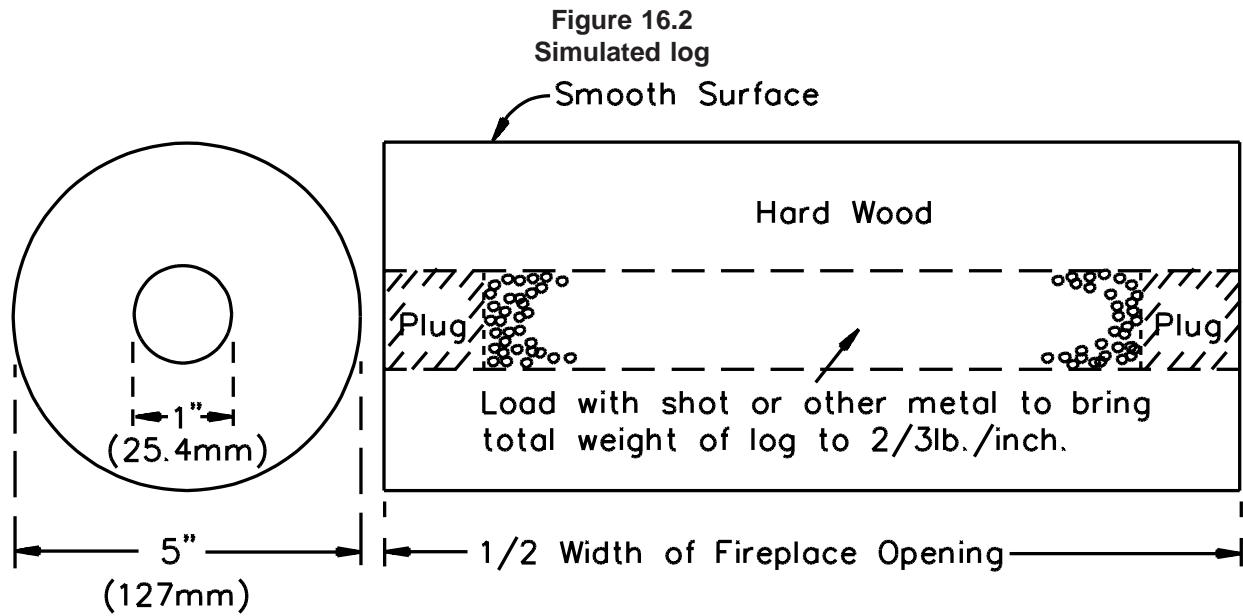

S2422

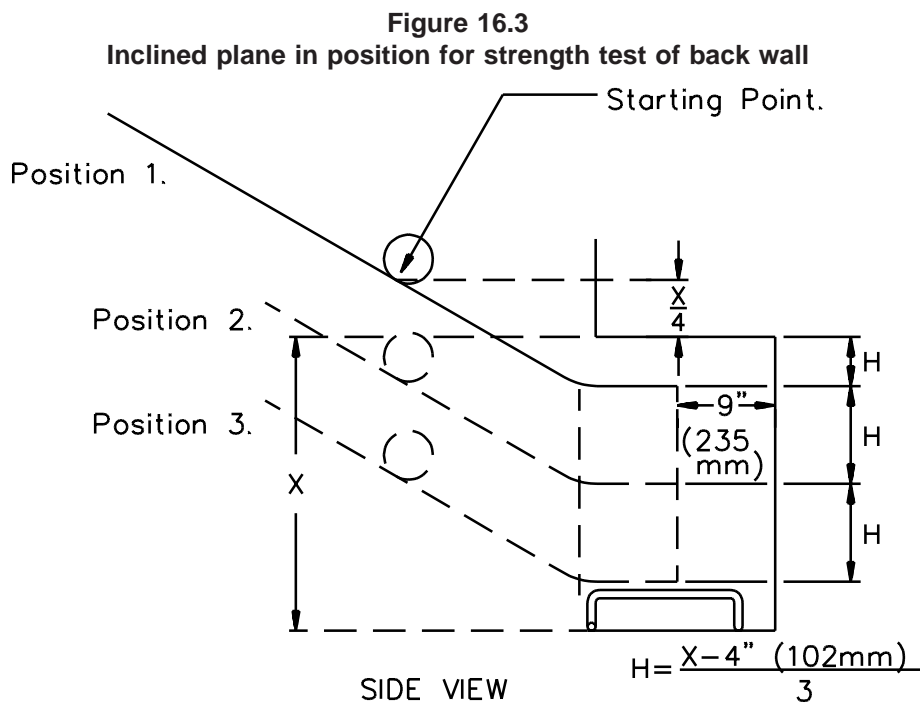

S2423

Figure 16.4
Inclined plane in position for strength test of back and side walls

Figure 16.4 revised January 26, 1998

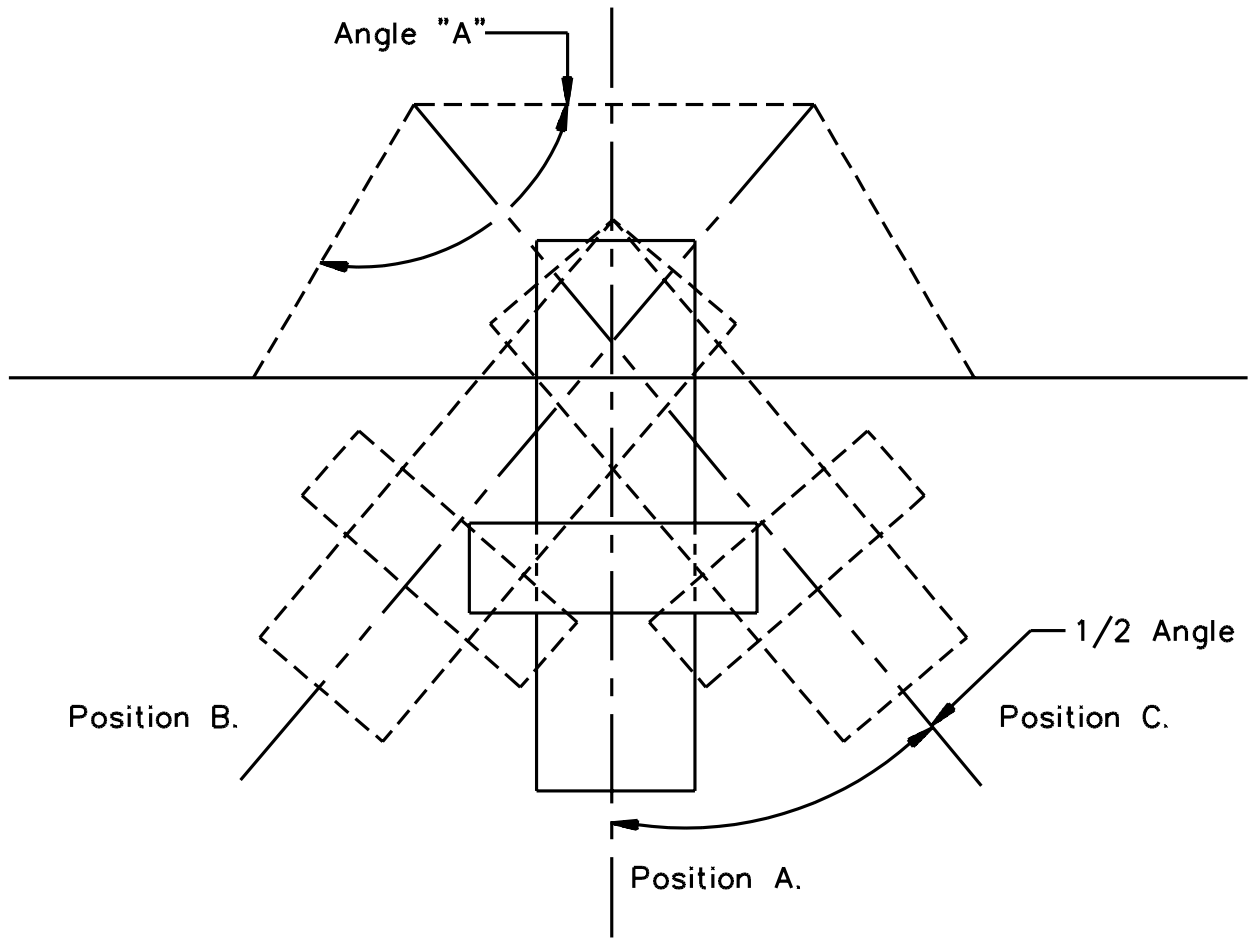

TOP VIEW

S2424

16.3 While remaining in position "A" as illustrated in Figure 16.4, the inclined plane is to be elevated successively to each of the three positions shown in Figure 16.3 and the simulated log is to be rolled down the plane once at each elevation of the plane, for a total of three impacts against the back wall of the fire chamber.

16.4 The test described in 16.3 is to be repeated with the inclined plane in position "B" (Figure 16.4) and then in position "C", for a total of six additional impacts.

16.5 With the inclined plane remaining in position "A" as illustrated in Figure 16.4, the andirons are to be positioned successively in the three positions shown in Figure 16.5. The slope of the inclined plane then is to be adjusted so that the simulated log to roll down the plane and impact the rear half of the andiron. There is to be one impact at each position of the andiron, for a total of three impacts.

No Text on This Page

Figure 16.5
Inclined plane in position for strength test of hearth^a

Figure 16.5 revised January 26, 1998

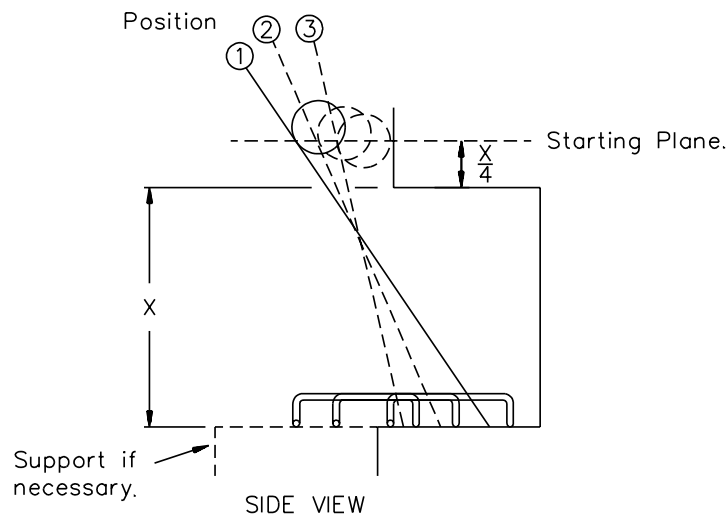

S2425

^a No one point on the hearth is to be struck repeatedly. The andirons shall be moved from side to side as well as in and out.

16.6 The back wall, side walls, and hearth of the fire chamber shall withstand the successive impacts on their surfaces resulting from the tests described in 16.3 – 16.5 without being damaged to the extent that the fireplace assembly is not capable for further use. Ceramic materials shall not break away, become dislodged, or show cracks opened more than 1/64 inch (0.4 mm) through the full depth of the material.

16.7 The hearth area within the combustion zone then is to be subjected to a uniform static load of 100 pounds per square foot (489 kg/m²) applied directly to the hearth area with the andirons removed. There shall be no permanent distortion or damage to the hearth area or to any part of the fireplace.

16.8 The area of a hearth extension furnished with the assembly then is to be subjected to a static load of 400 pounds (181.6 kg) applied to various 1/4 square foot (2.32 dm²) areas at different points on the extension. There shall be no permanent distortion or damage to the hearth extension area or to any part of the fireplace.

16.9 The outside edge of a fireplace hearth supported from a wall structure, or otherwise unsupported directly by the floor beneath the fire chamber, then is to be subjected to a static load of 300 pounds (136.2 kg) applied through the flat surface of a trade size 2- by 4-inch [nominal 1-1/2 by 3-1/2 inches (38.1 by 88.9 mm)] wood member laid perpendicular to the edge and on the center line of the fireplace opening. Ornamental or other trim that is damaged by this test is to be removed. There shall be no permanent distortion or damage to the hearth edge, to the fireplace or its support, or to the wall structure.

17 Chimney Strength Test

17.1 General

17.1.1 A chimney or its parts shall not break, disassemble, or become damaged to the extent that they are not capable for further use as a result of three impacts of a sand bag applied as described in 17.2.1 – 17.2.4.

17.1.2 Chimney parts shall not break, disassemble, or become damaged to the extent that they are not capable of further use when subjected to a longitudinal force of 100 pounds (445 N) applied as described in 17.3.1 and 17.3.2.

17.1.3 A support for an elbow shall sustain a load equivalent to four times the weight of the longest chimney section between adjacent supports. See 17.4.1.

17.1.4 A chimney joint of an offset chimney shall sustain a load equivalent to four times the weight of the vertical portion of the chimney length between the supports applied as described in 17.5.1.

17.1.5 Chimney parts shall not separate or disengage when subjected to torsional forces exerted by chimney cleaning brushes as described in 7.3.2.

17.2 Impact test

17.2.1 With reference to the requirements in 17.1.1, the impact is to be applied to an unenclosed chimney installed as shown in Figure 17.1. Tests shall be conducted on samples of each chimney size. Each section is to be joined together as specified by the manufacturer. When cemented joints are included in an assembly, the cement is to be dry before a test is conducted.

17.2.2 The impact is to be produced by a pendulum consisting of a rope suspending a cloth bag filled with sand and having the weight as shown in Figure 17.1. The bag is to be formed by tightly drawing up all sides and corners of a flat section of canvas around the sand and tying the excess canvas. The bag is to have an at-rest position with not more than 1 inch (25.4 mm) distance between the edge of the bag and the surface of the chimney. The point of impact is to be on the same horizontal plane as the center of gravity of the bag at rest. The distance of swing is to be that required to raise the center of gravity of the bag to the elevation specified in Figure 17.1 above the center of gravity of the bag at its at-rest position.

17.2.3 The length of the pendulum varies, based upon the intended point of impact.

Figure 17.1
Strength test

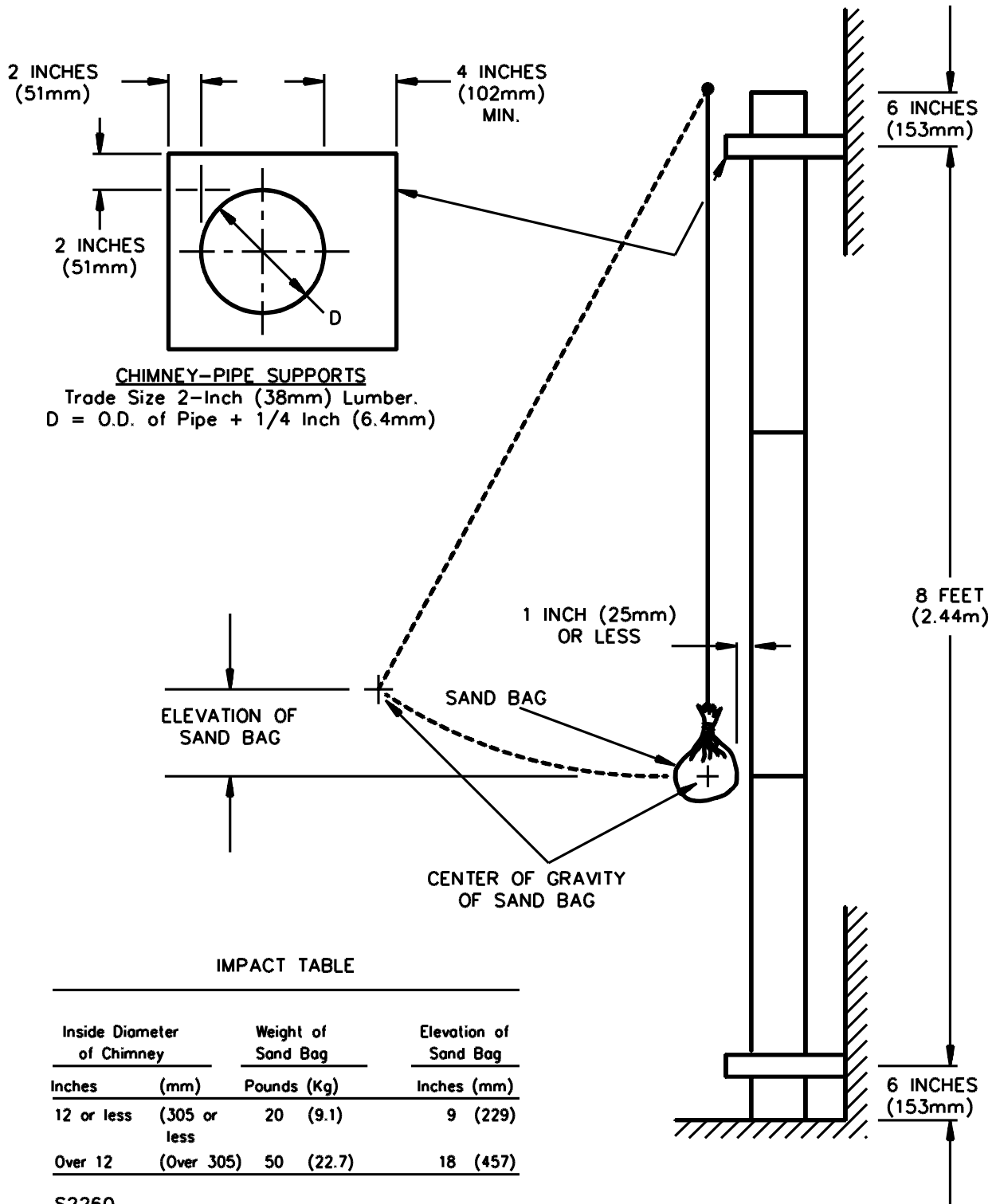

IMPACT TABLE

Inside Diameter of Chimney		Weight of Sand Bag		Elevation of Sand Bag
Inches	(mm)	Pounds	(Kg)	Inches (mm)
12 or less	(305 or less)	20	(9.1)	9 (229)
Over 12	(Over 305)	50	(22.7)	18 (457)

S2260

17.2.4 The three impacts are to be made successively at the following points:

- a) At the level of a joint;
- b) At the level halfway above the first joint tested and the next joint; and
- c) At the same level as in (b), and rotated around the axis of the chimney by 90 degrees from the impact in (b).

17.3 Longitudinal force test

17.3.1 With reference to the requirements in 17.1.2, the longitudinal force is to be applied on a number of chimney assemblies, as required to provide for representative samples of each size of part intended to be field-joined together. The force is to be exerted on the assembly in a direction tending to pull the assembly apart. When cemented joints are included in an assembly, the cement is to be dry before a test is conducted.

17.3.2 Two or more companion parts are to be joined in accordance with the manufacturer's instructions. A longitudinal force of 100 pounds (445 N) is to be applied first to the flue-gas-conveying conduit, then to the outer jacket or casing.

17.4 Load test for chimney elbows

17.4.1 The test to determine compliance with the requirements of 17.1.3 is to be performed as illustrated in Figure 17.2. Elbows are to be tested using an elbow chimney section having the greatest angle from the vertical specified by the manufacturer and installed directly on the chimney section. A vertical load, equivalent to four times the weight of the longest supported section of the chimney that is intended to be attached to the elbow, is to be applied through the center of gravity of the section. The load is to be sustained for 5 minutes.

17.5 Chimney joint load test

17.5.1 The test to determine compliance with the requirements in 17.1.4 is to be performed as illustrated in Figure 17.3. The maximum inclined length of flue-pipe between supports is to be assembled and installed on supports as shown. A vertical load, equal to four times the weight of the length of the chimney between supports, is to be applied at the joint located centrally between the supports. The load is to be sustained for 5 minutes.

Figure 17.2
Load test for chimney elbows

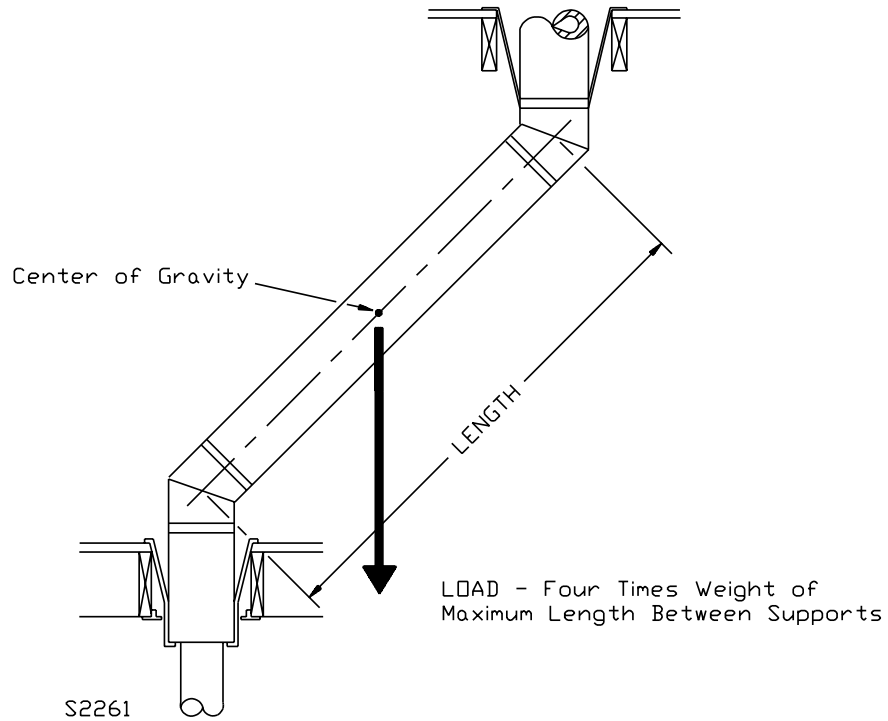
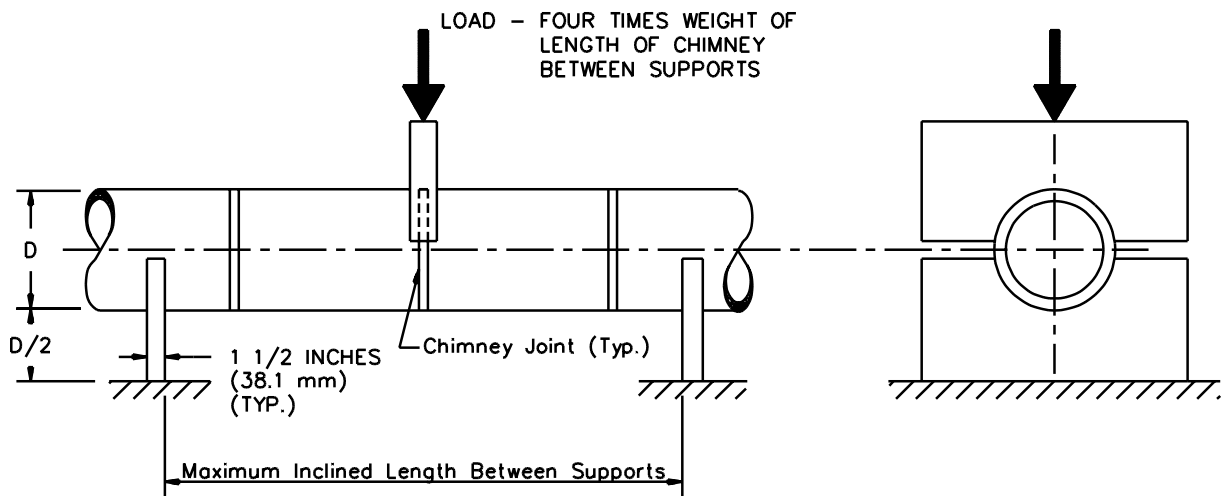

Figure 17.3
Chimney joint load test load



17.6 Chimney joint torsion test

17.6.1 With reference to the requirements in 17.1.5, the torsion is to be applied to a minimum of three chimney sections of the maximum length, secured to the support assembly. A metal chimney cleaning brush sized to fit the chimney flue is to be inserted to the midpoint of the top section and turned ten times to simulate cleaning methods. The chimney parts shall not separate or disengage.

18 Wind Load Test

18.1 A roof assembly shall resist, without damage or opening of joints, a load equivalent to 30 pounds per square foot (146 kg/m^2) of exposed area applied to any surface extending above the roof, when tested as described in 18.2 – 18.4.

18.2 The test is to be made on the tallest roof assembly representative of each style furnished by the manufacturer. The assembly is to be installed in a flat roof deck as described in the manufacturer's installation instructions.

18.3 The projected area of the largest surface of the roof assembly exposed to wind is to be computed by multiplying the diameter or the widest average dimension of the roof assembly, whichever is greater, by the greatest height of the assembly measured from the roof to the top of the chimney.

18.4 A load equivalent to the product of the projected area multiplied by an assumed wind pressure of 30 pounds per square foot (146 kg/m^2) is to be applied to the surface of the assembly in a horizontal direction. When a uniform surface load is not capable of being applied, the load is to be applied at the middle of the height used to calculate the projected area so that the load is evenly distributed over as much of the surface as required. See Figure 18.1. The load is to be sustained for a period of 1 hour as a static load.

Figure 18.1
Wind load test

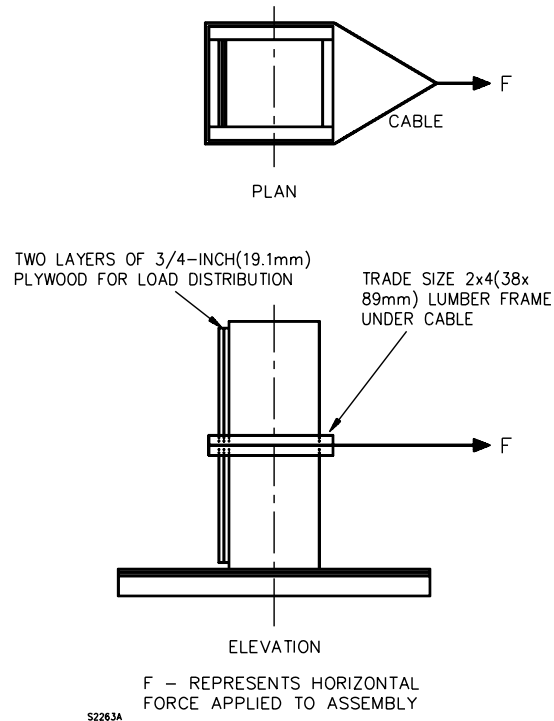

19 Rain Test

19.1 The quantity of water entering the flue-gas conduit, ventilation openings provided as part of a roof assembly, or any other individual passageway, shall not exceed 2 percent of that which enters the conduit, ventilation openings, or passageway when unprotected by a cap or other means, when tested as described in 19.2 – 19.6.

19.2 Representative sizes and styles of caps, roof assemblies, and roof jacks are to be subjected to the tests described in 19.3 – 19.6. The chimney section, roof assembly, or roof jack is to be sealed or flashed into a roof section of watertight material that sheds the water spray away from the underside of the test assembly. In this arrangement, any water entering the test assembly from above is to be observed at the underside of the simulated roof and collected.

19.3 The rain test apparatus is to consist of three spray heads mounted in a water-supply pipe rack illustrated in Figure 19.1. Spray heads are to be constructed in accordance with the details illustrated in Figure 19.2. The water pressure for all tests is to be maintained at 5 psig (34.5 kPa) at each spray head. The spray is to be directed toward the top and side of the cap, roof assembly, or roof jack. The cap, roof assembly, or roof jack is to be centrally located within the spray pattern and the top of the cap, roof assembly, or roof jack under test is to be at least 3 feet (0.9 m) below the plane of the lower spray head outlet.

Figure 19.1
Rain-test spray-head piping

Figure 19.1 revised January 26, 1998

PLAN VIEW

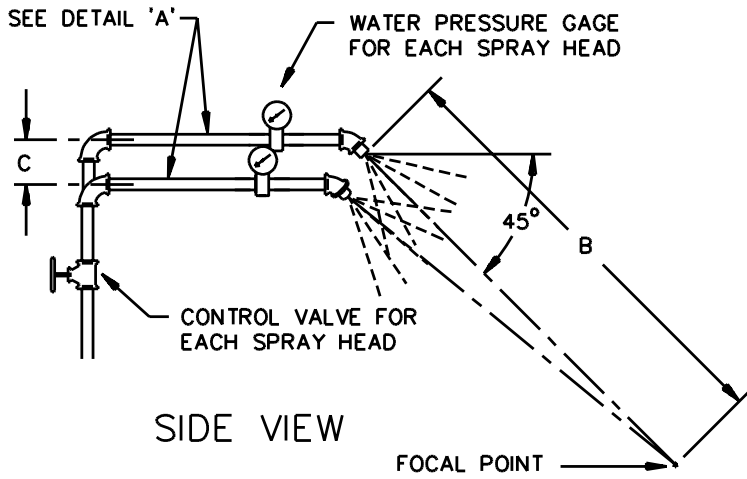
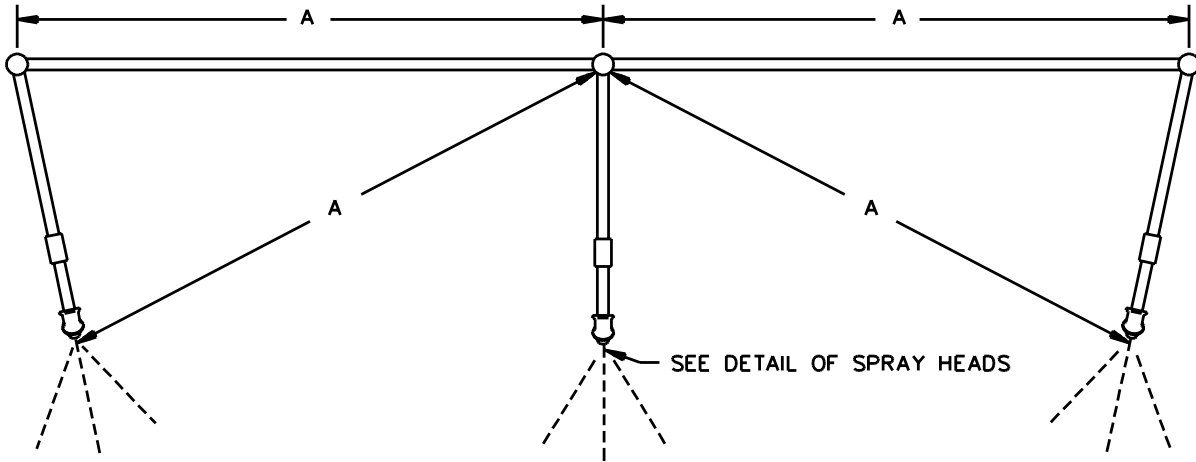

PIEZOMETER ASSEMBLY
DETAIL 'A'

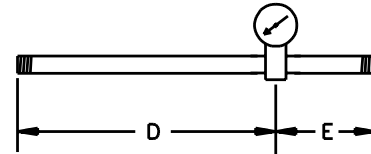

Item	inch	mm
A	28	710
B	55	1400
C	2-1/4	55
D	9	230
E	3	75

RT101E

Figure 19.2
Rain-test spray head

Figure 19.2 revised January 26, 1998

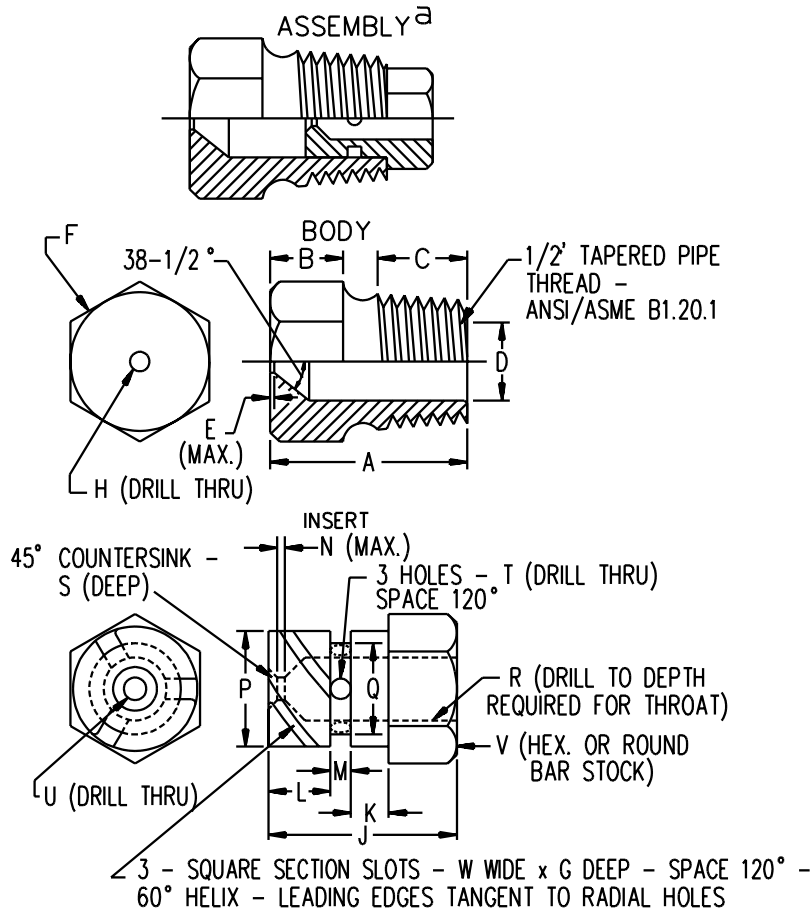

Item	inch	mm	Item	inch	mm
A	1-7/32	31.0	N	1/32	0.80
B	7/16	11.0	P	.575	14.61
C	9/16	14.0		.576	14.63
D	.578	14.68	Q	.453	11.51
	.580	14.73	R	.454	11.53
E	1/64	0.40	S	1/32	0.80
F	c	c	T	(No. 35) ^b	2.80
G	.06	1.52	U	(No. 40) ^b	2.50
H	(No.9) ^b	5.0	V	5/8	16.0
J	23/32	18.3	W	0.06	1.52
K	5/32	3.97			
L	1/4	6.35			
M	3/32	2.38			

^a Nylon Rain-Test Spray Heads are available from Underwriters Laboratories

^b ANSI B94.11M Drill Size

^c Optional - To serve as a wrench grip.

RT100E

19.4 The average rate of simulated rainfall in inches per hour over an area 12 inches in diameter with the water pressure at 5 psig (34.5 kPa) is to be determined as follows. A 12-inch (305-mm) diameter cylindrical container, open at one end and 20 inches (508 mm) deep, is to be used to collect the rainfall for 30 minutes. The center of the end of the container is to be located at the same position as the center of the upper surface or plane of the cap or assembly to be tested. The inches of rainfall collected in 30 minutes is to be multiplied by two to determine the rainfall in inches per hour.

19.5 For the rain test of an assembly, arrangements are to be made for collecting, in separate containers, any water entering the flue-gas conduit and any ventilation air passageway of a given configuration. The rain test is to cover a period of 1 hour.

19.6 The maximum amount of water collected in either the flue gas conduit or in any ventilation air passageway shall not exceed the value obtained by application of the formula:

$$Q \leq 0.02 \times R \times A$$

In which:

Q = Volume of water actually collected, cubic inches per hour;

R = Rainfall, inches per hour; and

A = Area of conduit or passageway, square inches.

20 Crushing Test of Nonmetallic Flue-Gas Conduit or Insulation

20.1 Each of eight full size chimney sections of each size of nonmetallic flue-gas conduit of insulation shall sustain without visible damage a load of not less than 450 pounds (204 kg) when tested as described in 20.2 – 20.5.

20.2 The samples used in this test are to be full-size sections, free of cracks. The face of each end of the samples is to be perpendicular to the axis of the chimney section and is to be ground smooth or capped with plaster to obtain uniform distribution of loading.

20.3 At least eight 4-inch (100-mm) long samples of each size are to be tested. Four samples of each size are to be tested in the as-received condition. The remaining four samples are to be placed in an electrically-heated oven whose temperature is initially at room temperature and then increased at the rate of 55°C per minute to 550°C and maintained at this temperature for 24 hours. The samples then are to be removed and cooled to room temperature prior to application of the load.

20.4 Any method that applies the load progressively or in increments not exceeding 5 percent of the estimated total breaking load is used for this test. When the load is applied in increments, the samples are not to remain in any loaded condition longer than is required for observing and recording the load values.

20.5 The bed of the testing machine is to be used as the bottom bearing surface. The bed is to be made of flat steel. Pressure on the top of the sample is to be applied by a bearing block maintained parallel to the bed of the machine. The construction and operation of the bearing frames and bearing blocks are to maintain a uniform distribution of the applied load. The samples are to be placed so as to secure a symmetrical distribution of the loading.

21 Resistance to Action of Acids Test of Nonmetallic Flue-Gas Conduit

21.1 The percentage of acid-soluble matter in each sample of nonmetallic flue-gas conduit material shall not exceed 3.0 percent by weight when tested as described in 21.2 and 21.3.

21.2 A sample of each nonmetallic flue-gas conduit material is to be subjected to this test. Each sample is to have a square face area and is to be the maximum thickness used in the conduit. The total surface area is to be measured. The samples are to be washed with hot water and dried to constant weight in a ventilated oven at a temperature between 105 and 110°C.

21.3 Upon attaining constant weight, the samples are to be suspended and completely immersed in a 1/50 normal sulfuric acid solution [40 cubic centimeters of solution for each square inch (6.5 cm²) of sample surface area] at a temperature between 21 and 32°C (70 – 90°F) for a period of 24 to 48 hours. The samples then are to be removed from the solution, washed with hot water, and dried to constant weight in a ventilated oven at a temperature between 105 and 110°C (221 – 230°F). This weight then is to be compared with the weight obtained as described in 21.2.

22 Freezing and Thawing Test of Water-Absorptive Nonmetallic Materials

22.1 Parts of nonmetallic materials that absorb water shall not show disintegration, cracking, or spalling, or loss of weight of more than 5 percent of the initial dry weight after being subjected to the freezing and thawing treatment described in 22.2 – 22.5.

22.2 The samples of each material to be tested are to be free of observable cracks, and shall not contain laminations and fissures unless they are representative of the material from which the samples are taken.

22.3 The samples are to be dried to constant weight in a ventilated oven at a temperature of 105 – 110°C (221 – 230°F). The samples then are to be submerged for 24 hours in water at a temperature of 18 – 24°C (64 – 75°F). The water then is to be heated to boiling temperature, maintained at this temperature for 5 hours, and then cooled to a temperature of 18 – 24°C. Each sample then is to be removed from the water, wiped dry with a cloth, and weighed immediately. The average water absorption by weight is to be calculated and recorded.

22.4 Representative samples of complete parts then are to be required to be free of observable cracks or shattered edges. The samples shall not contain laminations and fissures unless they are representative of the material from which the samples are taken.

22.5 The samples are to be dried to constant weight in a ventilated oven at a temperature between 105 and 110°C (221 – 230°F) and the weights recorded. The samples then are to be immersed for 72 hours in water at a temperature of 18 – 24°C (64 – 75°F), then removed from the water and drained for not more than 1 minute. The superficial moisture is to be removed with a towel or blotting paper and the samples immediately subjected to ten conditioning cycles. Each conditioning cycle is to consist of exposure to a temperature of minus 18°C for 16 hours, followed by exposure to a temperature of 110°C for 7 hours, and then followed by immersion in water for 1 hour. These cycles are to be continued for 240 hours, except that once during the test the samples are to remain at the temperature of minus 18°C for 64 consecutive hours. At the end of the test period, the samples are to be dried to constant weight, and the weight recorded.

23 Cemented Joint Test of Flue-Gas Conduit

23.1 There shall be no evidence of softening or leaching of the cement used for joining sections of flue-gas conduit following the tests described in 23.2 and 23.3.

23.2 Four samples are to be prepared of each style of joint used between two sections of the flue-gas conduit. The length of the test assembly shall be no longer than required to include the complete joint.

23.3 The samples are to be dried to constant weight in a ventilated oven at a temperature between 105 and 110°C (221 – 230°F). Each sample then is to be placed in an ambient temperature between 21 and 32°C (70 – 90°F), and mounted with the axis of the assembly in a vertical position. The bottom of the assembly is to be sealed to retain liquid, and the assembly is to be filled with a 1/50 normal sulfuric acid solution to a level 1 inch (25.4 mm) above any cemented portion of the joint. The solution is to be maintained at that level for 72 hours. The solution then is to be removed and the test repeated, except that water is to be used in place of the sulfuric acid solution. See Figure 23.1.

Figure 23.1
Test of cemented joints

Figure 23.1 revised January 26, 1998

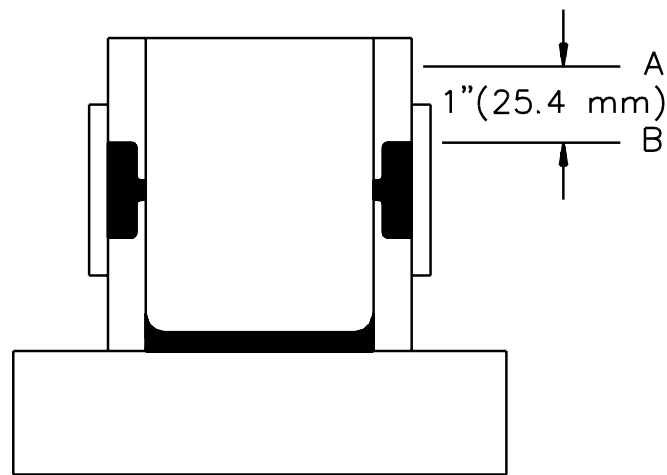

A – Liquid level
B – Highest level of cement

S2428

24 Sulfuric Acid Extraction Test for Porcelain-Coated Steel Used for Flue-Gas Conduit

24.1 The loss in weight of porcelain-coated steel used for flue-gas conduit shall be not greater than 0.30 percent following the tests described in 24.2 and 24.3.

24.2 Two samples are to be tested, each 2- by 2-inches (50- by 50-mm) in face area. When seams are incorporated in the product, each sample is to include the conduit seam. The samples are to be weighed and the thickness of the base metal determined. The sample weights are to be adjusted to a base metal thickness of 0.026 inch (0.66 mm). The edges of the samples are to be coated with wax.

24.3 The samples are to be suspended completely immersed in a solution containing 20 percent by weight sulfuric acid, and at a temperature between 21 and 32°C (70 – 90°F), for a period of 44 hours. After removal from the solution, the samples are to be cleaned, dried, and weighed; and the loss of weight is to be calculated and recorded as a percent of the original adjusted dry weight.

No Text on This Page

25 Glazing Test

25.1 General

25.1.1 Glazing shall not crack, break, become dislodged, or sustain a loss of strength when the fireplace is subjected to the Radiant Fire Test, Section 12; Brand Fire Test, Section 13; and Flash Fire Test, Section 14.

25.1.2 When the glazing material is shielded from the room by a screen or wire mesh having openings less than 1/4 by 1/4 inch (6.4 by 6.4 mm) and the screen is secured to the frame, the glazing shall not crack or break when subjected to the Radiant Fire Test, Section 12; Brand Fire Test, Section 13; Flash Fire Test, Section 14; and tested as described in 25.2.1 – 25.3.1, unless the screen is not damaged (torn, dislodged or punctured) by these tests. When the glazing cracks or breaks, the fireplace is to be subjected to these tests with the glazing material both in place (intact) and with one glazing panel removed.

25.2 Impact test

25.2.1 Glazing shall withstand, without cracking or breaking, the impact described in 25.2.2 :

- a) Prior to the Radiant Fire Test, Section 12, or Brand Fire Test, Section 13 (whichever test is conducted first), while at room temperature;
- b) During the Radiant Fire Test, while at the maximum temperature developed during that test;
- c) Following the Radiant Fire Test, after being cooled to room temperature;
- d) During the Brand Fire Test, while at the maximum temperature developed during that test;
- e) Following the Flash Fire Test, Section 14, after being cooled to room temperature; and
- f) For outdoor fireplaces, during the hot and cold exposure conditioning test, Sub-section 25C.2.

25.2.1 revised November 9, 1999

25.2.2 An impact is to be applied to the center of the glazing panel by means of a 1.18 pound (0.54 kg), 2 inch (50.8 mm) diameter steel sphere swung through a pendulum arc from a height (h) of 16.25 inches (413 mm). The at-rest suspension point of the steel sphere is to be 1 inch (25.4 mm) in front of the plane of the panel. See Figure 25.1.

25.3 Water shock test

25.3.1 While at the maximum temperature developed during the Radiant Fire Test, Section 12, each glazing panel shall withstand, without cracking or breaking, the application of:

- a) A wet cloth, fully saturated with water at room temperature, wiped across the surface of each glazing panel; and
- b) Three misted water sprays projected across the surface of each glazing panel from a household cleaning bottle with a gun-type nozzle, applied after the panel is dried and again attains the maximum temperature under the heated condition.

Figure 25.1
Impact test

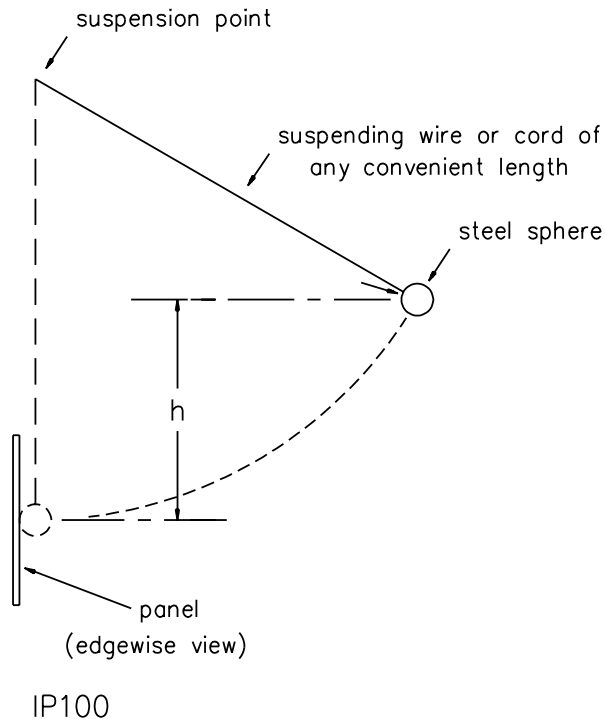

OUTDOOR FIREPLACES

25A General

25A.1 Fireplaces intended for outdoor use shall comply with Sections 25B – 25E, in addition to the requirements of Sections 1 – 25 and 27 – 54.

25A.1 added November 9, 1999

25B Construction

25B.1 The unit assembly shall be fabricated from Type 430 stainless steel or G-90 coated galvanized steel for the outer unit wrap only to reduce the effects of corrosion. Additionally, all fastening means shall be able to withstand the conditions anticipated during outdoor use. In order to facilitate water runoff, the hearth pan shall have a pitch of a minimum of 1/4 inch per foot forward.

25B.1 added November 9, 1999

25C Performance

25C.1 General

25C.1.1 A fireplace intended for outdoor use shall be subjected to the hot and cold conditioning test, freezing and thawing tests for refractory materials, and the wind test described in 25C.2 – 25C.4.

25C.1.1 added November 9, 1999

25C.2 Hot and cold conditioning test

25C.2.1 The following tests and conditioning operations for fireplaces intended for outdoor use are to be repeated for three cycles. The first and second cycle are to consist of the requirements specified in 25C.2.2 – 25C.2.6. The third cycle is to consist of the requirements specified in 25C.2.2 – 25C.2.5 and 25C.2.7. Upon completion of the three cycles, a fireplace intended for outdoor use shall not exhibit a cracked refractory, broken glass panels, deformed metal panels, broken welds or fasteners, or any other condition which potentially increases the risk of injury or fire.

25C.2.1 added November 9, 1999

25C.2.2 Prior to beginning each cycle of tests and conditioning operations, the fireplace is to be at room temperature.

25C.2.2 added November 9, 1999

25C.2.3 All fireplace doors are to be opened and the fireplace front face and hearth area, including the hearth refractory, are to be subjected to a water spray using the rain test apparatus as described in Section 19, Rain Test, for 5 minutes.

25C.2.3 added November 9, 1999

25C.2.4 Following completion of the water conditioning, all fireplace doors are to be closed and the fireplace placed in a cold chamber that is maintained at 0°F(-18°C). The fireplace is to remain in the cold chamber for 24 hours, then removed.

25C.2.4 added November 9, 1999

25C.2.5 Within 2 minutes of removal from the cold chamber, any glass panels which the fireplace is provided with are to be subjected to the impact test of 25.2. Following the impact test, the fireplace doors are to be fully opened and the Fire Chamber Strength Test of Section 16 is to be conducted on the fireplace refractory.

25C.2.5 added November 9, 1999

25C.2.6 During the first and second cycles of testing and conditioning following the Fire Chamber Strength Test, the Flash Fire Test of Section 14 is to be performed. After the Flash Fire Test is complete, the fireplace is to cool for 30 minutes, after which any remaining coals are to be removed. The next cycle of testing and conditioning is to then begin.

25C.2.6 added November 9, 1999

25C.2.7 During the third cycle of testing and conditioning, the fireplace is to be installed into the temperature test enclosure used for the Brand and Flash Fire Tests of Sections 13 and 14, respectively. The fireplace is then to be subjected to the Brand and Flash Fire Tests. The fireplace shall perform in accordance with the requirements specified in Sections 13 and 14.

25C.2.7 added November 9, 1999

25C.3 Freezing and thawing tests for refractory materials

25C.3.1 Prior to undergoing the tests and conditionings described in 25C.3.2 – 25C.3.5, representative samples of the fireplace's refractory material are to be free from cracks that can be observed unaided. The samples are able to contain laminations and fissures when the laminations and fissures are representative of the overall refractory material. When subjected to the tests and conditionings described in 25C.3.2 and 25C.3.3, refractory samples shall not disintegrate, crack, nor exhibit spalling. Additionally, the samples shall not lose more than five percent of their initial dry weight. As a result of the conditionings described in 25C.3.4 and 25C.3.5, refractory samples shall neither break nor crack.

25C.3.1 added November 9, 1999

25C.3.2 Three refractory samples are to be dried to constant weight in a ventilated oven at a temperature of 212 – 221°F (100 – 105°C) and the weights measured. The samples are then to be submerged for 24 hours in water at a temperature of 64 – 75°F (18 – 24°C). The water is then to be heated to boiling temperature, maintained at this temperature for 5 hours, then allowed to cool to a temperature of 64 – 75°F (18 – 24°C). Each sample then is to be removed from the water, wiped dry with a cloth, and weighed immediately. The water absorption by weight is to be calculated and recorded.

25C.3.2 added November 9, 1999

25C.3.3 Following the conditioning of 25C.3.2, the samples are to be dried to constant weight in a ventilated oven at a temperature between 212 and 221°F (100 and 105°C) and the weights recorded. The samples are then to be immersed for 72 hours in water at a temperature of 64 – 75°F (18 – 24°C), and then removed from the water and allowed to drain for not more than 1 minute. The superficial moisture is to be removed with a towel or blotting paper and the samples immediately subjected to three conditioning cycles. Each conditioning cycle is to consist of exposure to a temperature of -40°F (-40°C) for 16 hours, followed by exposure to a temperature of 212°F (100°C) for 7 hours, and then followed by immersion in water for 1 hour. At the end of the test period, the samples are to be dried to constant weight, and the weight measured. The samples are to be inspected for cracking, disintegration, and spalling.

25C.3.3 added November 9, 1999

25C.3.4 Three previously untested samples of the refractory are to be immersed in water for 24 hours and then placed in a -40°F (-40°C) cold chamber for 24 hours. The samples are then to be removed and allowed to reach room ambient temperature. The samples are then to be inspected for breakage and cracking.

25C.3.4 added November 9, 1999

25C.3.5 One previously untested set of refractory samples is to be submerged into water at room temperature for a period of 24 hours. The refractory samples are to be removed from the water after 24 hours and reinstalled into the fireplace. The fireplace is to then be subjected to the Flash Fire Test specified in Section 14. The samples are then to be inspected for breakage and cracking.

25C.3.5 added November 9, 1999

25C.4 Wind test

25C.4.1 The Brand Fire Test, specified in 13.2 – 13.9, is to be performed while the wind test specified in 25C.4.2 and 25C.4.3, is performed. The fireplace is to be installed in the test enclosure used to perform the Brand Fire Test. The maximum temperature rise of the test enclosure surfaces above ambient temperature shall conform to the requirements of 13.11.

25C.4.1 added November 9, 1999

25C.4.2 During the Brand Fire Test as described in 13.2 – 13.9, the fireplace is to be subjected to a wind starting at 5 miles per hour rising in 5 miles per hour increments to 40 miles per hour. At each increment, the fireplace doors are to be open, the wind is to impinge on the opening first at 90° to the hearth opening, then 45° to the hearth opening. The fireplace doors are then to be closed, and the wind again made to impinge at 90° and then 45° to the hearth opening. The equilibrium temperatures of the test enclosure surfaces are to be measured at each wind impingement.

25C.4.2 added November 9, 1999

25C.4.3 When a wind speed of 40 miles per hour is reached and the equilibrium temperatures of the test enclosure surfaces are found to be still increasing with wind speed, the wind speed is to continue to be increased in 5 mph increments. This process is to continue until the equilibrium temperature no longer increases with wind speed.

25C.4.3 added November 9, 1999

25D Marking

25D.1 In addition to the applicable marking requirements in Section 52, a fireplace intended for outdoor use shall be marked with the statement: "WARNING" then the following or equivalent statement: "TO AVOID THE RISK OF DAMAGING FIREPLACE MATERIALS AND INCREASING THE RISK OF SPREADING A FIRE, DO NOT USE THE FIREPLACE TO COOK OR WARM FOOD."

25D.1 added November 9, 1999

25E Operating instructions

25E.1 In addition to the applicable operating instruction requirements in Section 54.3, the operating instructions for a fireplace intended for outdoor use shall include the word "WARNING" and the following or equivalent statement: "TO AVOID THE RISK OF DAMAGING FIREPLACE MATERIALS AND INCREASING THE RISK OF SPREADING A FIRE, DO NOT USE THE FIREPLACE TO COOK OR WARM FOOD."

25E.1 added November 9, 1999

FIREPLACES FOR USE IN MANUFACTURED HOMES

26 General

26.1 Installation

26.1.1 Fireplace for use in manufactured homes are intended for installation in accordance with the requirements of the Department of Housing and Urban Development (HUD) "Manufactured Home Construction and Safety Standards."

Revised 26.1.1 effective January 13, 2000

26.1.2 A fireplace for use in manufactured homes shall comply with all requirements elsewhere in this standard unless otherwise specified in this section.

Revised 26.1.2 effective January 13, 2000

26.1.3 Means shall be provided for securing the fireplace to the floor of the manufactured home.

Revised 26.1.3 effective January 13, 2000

26.1.4 A spark arrester and combustion air inlet shall be shipped with the fireplace from the factory, and the fireplace shall be tested with the spark arrester installed.

26.1.4 revised November 9, 1999

26.1.5 With its chimney installed, the configuration of a fireplace shall not void the required firestopping between spaces of a manufactured home when the fireplace, chimney, and the combustion air inlet are installed in accordance with the manufacturer's instructions.

Revised 26.1.5 effective January 13, 2000

26.1.6 A fireplace shall be shipped from the factory with an integral door(s) or shutter(s) provided and constructed to close off the fire chamber from the living space.

26.1.6 revised November 9, 1999

26.2 Chimney

26.2.1 The chimney shall extend at least 3 feet (0.9 m) above the part of the roof through which it passes. The top of the chimney is to be at least 2 feet (0.6 m) above the highest required elevation of any part of the manufactured home located within 10 feet (3 m) of the chimney.

Revised 26.2.1 effective January 13, 2000

26.2.2 All roof-chimney terminations shall be able to be readily removed at or below an elevation of 13-1/2 feet (4.1 m) above ground level and reinstalled without the use of special tools or instructions.

26.2.3 When the chimney exits the manufactured home at a location other than through the roof, and exits at a point 7 feet (2.1 m) or less above the ground level on which the manufactured home is positioned, a guard or method of enclosing the chimney shall be provided at the point of exit so that the chimney is guarded or enclosed up to a height of 7 feet.

Revised 26.2.3 effective January 13, 2000

26.2.4 With reference to the requirements of 26.2.3, openings in a chimney guard shall not permit:

- a) The entrance of a 3/4 inch (19.1 mm) diameter rod; and
- b) Contact with the chimney of a 1/2 inch (12.7 mm) diameter rod inserted through the opening a distance of 4 inches (102 mm).

26.3 Spark arrester

26.3.1 The chimney shall be provided with a spark arrester secured to the chimney. The net free area of the arrester above the chimney outlet shall be not less than four times the net area of the chimney outlet, and the vertical height of the arrester above the chimney outlet shall be not less than one-half the diameter of the chimney flue. Openings shall prohibit the passage of a sphere having a diameter larger than 1/2 inch (12.7 mm), and shall let the passage of a sphere having a diameter of 3/8 inch (9.6 mm).

26.4 Combustion air inlet

26.4.1 The cross sectional area of the combustion air inlet shall be not less than 50 percent of the cross sectional flue area or 25 square inches (161 cm²), whichever is smaller. This inlet shall conduct the combustion air directly from outside the manufactured home to the connection to the draft inlet of the fire chamber assembly.

Revised 26.4.1 effective January 13, 2000

26.5 Test structure

26.5.1 The test structure is to consist of three walls, a floor and a ceiling and is to have inside dimensions of 7 feet (2.1 m) high by 8 feet (2.4 m) wide by 8 feet deep. Interior surfaces of walls, ceiling and floor are to be painted flat back. See Figure 26.1 for structural details.

26.6 Test method

26.6.1 The chimney of the fireplace is to pass through the ceiling/roof or wall of the manufactured home test structure at zero clearance. This is accomplished by a thimble or through the inherent construction of the chimney or fireplace. The construction shall not void the firestopping required for a concealed space when installed in accordance with the manufacturer's installation instructions.

Revised 26.6.1 effective January 13, 2000

Figure 26.1
Manufactured home test enclosure

Revised Figure 26.1 effective January 13, 2000

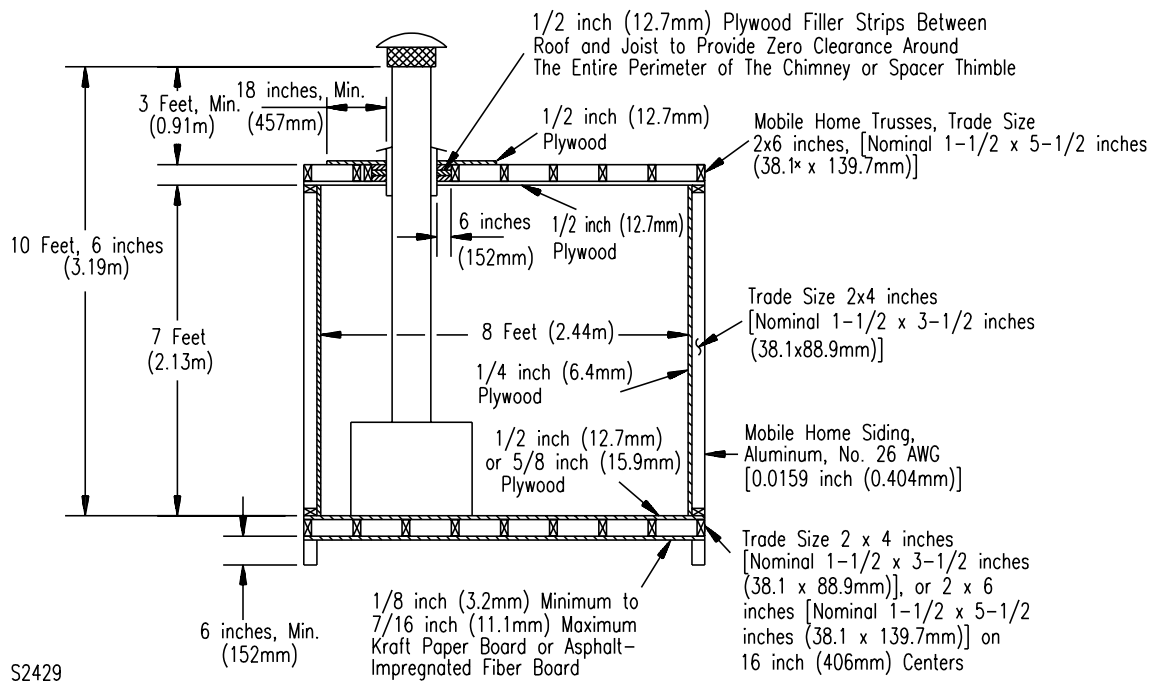

26.6.2 When the unit is equipped with an air inlet that penetrates the floor, a 3/8 inch (9.5 mm) thick plywood bottom board extending at least 8 inches (193 mm) from each side of the air inlet is to be applied to the bottom of the floor joist.

26.6.3 A fireplace intended for use in manufactured homes shall comply with the requirements in Sections 11 – 25.

Revised 26.6.3 effective January 13, 2000

26.6.4 As a continuation of the Radiant Fire Test, Section 12, the test structure is to be closed and sealed on all sides. Reading stations for monitoring CO concentration are to be located in a vertical plane perpendicular to and horizontally centered in relation to the plane of the fireplace.

26.6.5 The CO concentration during the test shall not exceed 50 ppm at any reading station during the entire test. See Figure 26.2.

No Text on This Page

Figure 26.2
Location of carbon monoxide reading stations

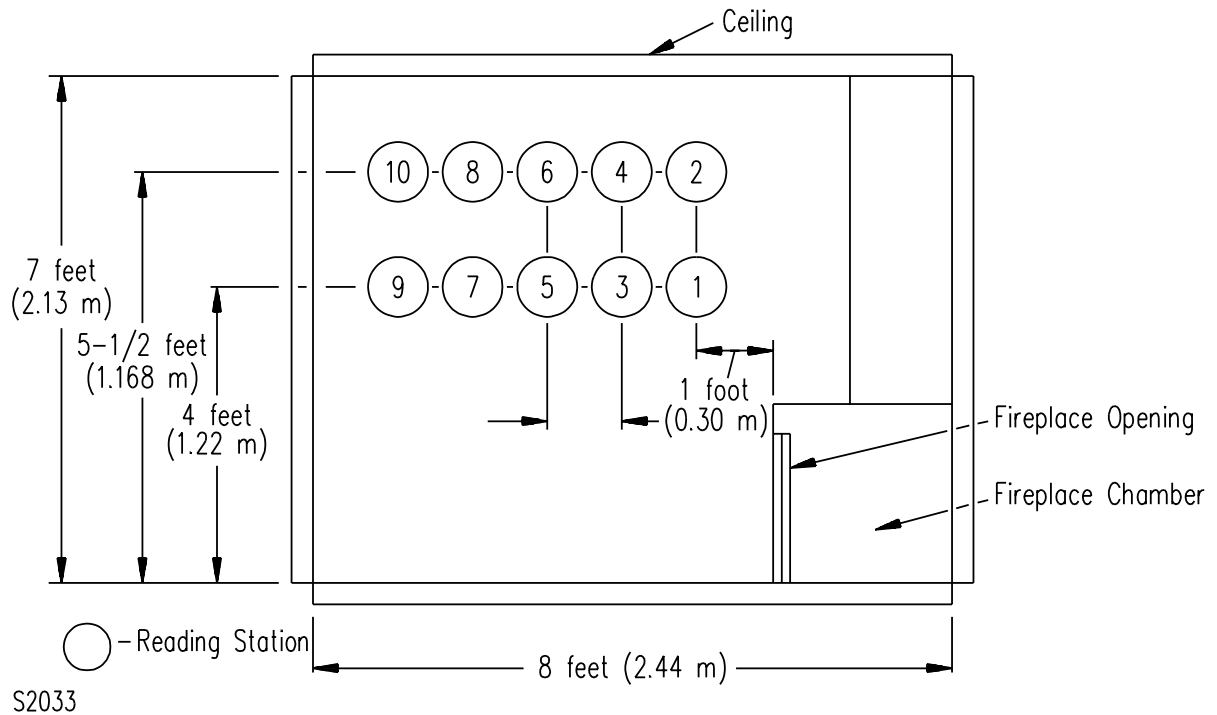

26.7 Drop test

26.7.1 At the conclusion of the fire tests, see Sections 12 – 14, the fireplace shall withstand the successive impacts described in 26.7.2. Ceramic materials shall not break away, become dislodged or show cracks more than 1/64 inch (0.4 mm) wide; welds shall not break and the fireplace assembly shall not be damaged to an extent that it is not capable of further use.

26.7.2 The fireplace chamber shall be raised 1 inch (25.4 mm) and dropped on a 3/4 inch (19.1 mm) thick sheet of plywood laid over a concrete floor. This test shall be repeated ten times.

BLOWER ASSEMBLY

GENERAL

27 General

27.1 A fireplace that includes a blower assembly shall comply with the requirements of the preceding sections of this standard and shall, in addition, comply with the requirements hereafter.

27.2 The construction and use of the blower assembly shall introduce a positive pressure into the fireplace.

27.3 Electrical circuits are classified as follows:

- a) High-Voltage Circuit – A circuit involving a potential of not more than 250 volts and having circuit characteristics in excess of those of a low-voltage circuit.
- b) Low-Voltage Circuit – A circuit involving a potential of not more than 30 volts ac (42.4 peak or direct current) and supplied by a primary battery or by a standard Class 2 transformer or other transforming device, or by a combination of transformer and fixed impedance having output characteristics in compliance with what is required for a Class 2 transformer. A circuit derived from a source of supply classified as a high-voltage circuit, by connecting resistance in series with the supply circuit as a means of limiting the voltage and current, is not identified to be a low-voltage circuit.

CONSTRUCTION

28 Enclosure

28.1 General

28.1.1 An electrical enclosure shall be formed and assembled so that it has the strength and rigidity required to resist the abuses to which it is subjected in intended use without total or partial collapse and subsequent reduction of spacings, loosening or displacement of parts, or other conditions that render it not capable of further use. An enclosure for individual electrical components, an outer enclosure, and combinations of the two are to be evaluated in determining compliance with this requirement.

28.1.2 Among the factors to be taken into consideration when evaluating an enclosure are mechanical strength, resistance to impact, moisture-absorptive properties, flammability, resistance to distortion at temperatures to which the material is subjected under conditions of use, and resistance to corrosion. For a nonmetallic enclosure or part of an enclosure all of these factors are to be identified with respect to aging.

28.1.3 The enclosure shall be constructed to reduce the risk of mechanical damage to wiring and electrical components.

28.1.4 The enclosure shall be constructed to reduce the risk of the emission of molten metal, burning insulation or flaming particles through openings onto flammable material, including surfaces over which the fireplace or blower assembly is mounted.

28.1.5 Unless malfunction of an electrical component does not result in a risk of fire, components, such as controls, solenoids, relays, and switches shall be individually enclosed except at terminals. See 28.1.6 for Exception.

28.1.6 Electrical parts within the outer cabinet are not required to be individually enclosed when the assembly complies with the following:

- a) Their construction and their location with respect to openings in the outer cabinet does not result in the emission of flame or molten metal through openings in the cabinet or the malfunction of the component shall not result in a risk of fire;
- b) There are no openings in the bottom of the compartment (in which the part is located) where there is dropping of molten metal on flammable material; and
- c) The part is not in proximity to flammable material other than electrical insulation.

28.1.7 Sheet metal complying with Tables 28.1 and 28.2, whichever applies, is capable of being used for the individual enclosure of electrical components.

28.1.8 When the construction and location of components and the strength and rigidity of the outer cabinet warrant, an individual enclosure thinner than specified in Tables 28.1 and 28.2, whichever applies, shall be employed.

Table 28.1
Minimum thickness of sheet metal for electrical enclosures – carbon steel or stainless steel

Without supporting frame ^a				With supporting frame or equivalent reinforcing ^a				Minimum thickness in inches (mm)			
Maximum width ^b		Maximum length ^c		Maximum width ^b		Maximum length		Uncoated (MSG)		Metal coated (GSG)	
Inches	(cm)	Inches	(cm)	Inches	(cm)	Inches	(cm)				
4.0	(10.2)	Not limited		6.25	(15.9)	Not limited		0.020	(0.51)	0.023	(0.58)
4.75	(12.1)	5.75	(14.6)	6.75	(17.1)	8.25	(21.0)	(24)		(24)	
6.0	(15.2)	Not limited		9.5	(24.1)	Not limited		0.026	(0.66)	0.029	(0.74)
7.0	(17.8)	8.75	(22.2)	10.0	(25.4)	12.5	(31.8)	(22)		(22)	
8.0	(20.3)	Not limited		12.0	(30.5)	Not limited		0.032	(0.81)	0.034	(0.86)
9.0	(22.9)	11.5	(29.2)	13.0	(33.0)	16.0	(40.6)	(20)		(20)	
12.5	(31.8)	Not limited		19.5	(49.5)	Not limited		0.042	(1.07)	0.045	(1.14)
14.0	(35.6)	18.0	(45.7)	21.0	(53.3)	25.0	(63.5)	(18)		(18)	
18.0	(45.7)	Not limited		27.0	(68.6)	Not limited		0.053	(1.35)	0.056	(1.42)
20.0	(50.8)	25.0	(63.5)	29.0	(73.7)	36.0	(91.4)	(16)		(16)	
22.0	(55.9)	Not limited		33.0	(83.8)	Not limited		0.060	(1.52)	0.063	(1.60)
25.0	(63.5)	31.0	(78.7)	35.0	(88.9)	43.0	(109.2)	(15)		(15)	
25.0	(63.5)	Not limited		39.0	(99.1)	Not limited		0.067	(1.70)	0.070	(1.78)
29.0	(73.7)	36.0	(91.4)	41.0	(104.1)	51.0	(129.5)	(14)		(14)	
33.0	(83.8)	Not limited		51.0	(129.5)	Not limited		0.080	(2.03)	0.084	(2.13)
38.0	(96.5)	47.0	(119.4)	54.0	(137.2)	66.0	(167.6)	(13)		(13)	
42.0	(106.7)	Not limited		64.0	(162.6)	Not limited		0.093	(2.36)	0.097	(2.46)
47.0	(119.4)	59.0	(149.9)	68.0	(172.7)	84.0	(213.4)	(12)		(12)	
52.0	(132.1)	Not limited		80.0	(203.2)	Not limited		0.108	(2.74)	0.111	(2.82)
60.0	(152.4)	74.0	(188.0)	84.0	(213.4)	103.0	(261.6)	(11)		(11)	
63.0	(160.0)	Not limited		97.0	(246.4)	Not limited		0.123	(3.12)	0.126	(3.20)
73.0	(185.4)	90.0	(228.6)	103.0	(261.6)	127.0	(322.6)	(10)		(10)	

^a A supporting frame is a structure of angle or channel or a folded rigid section of sheet metal that is rigidly attached to and has the same outside dimensions as the enclosure surface and that has torsional rigidity to resist the bending moments which shall be applied via the enclosure surface when it is deflected. Construction that is determined to have equivalent reinforcing shall be accomplished by designs that produces a structure that is as rigid as one built with a frame of angles or channels. Construction determined to be without supporting frame includes a single sheet with single formed flanges (formed edges), a single sheet that is corrugated or ribbed, and an enclosure surface loosely attached to a frame, for example, with spring clips.

^b The width is the smaller dimension of a rectangular sheet metal piece that is part of an enclosure. Adjacent surfaces of an enclosure shall have supports in common and be made of a single sheet.

^c For panels that are not supported along one side, for example, side panels of boxes, the length of the unsupported side shall be limited to the dimensions specified unless the side in question is provided with a flange at least 1/2 inch (12.7 mm) wide.

Table 28.2
Minimum thickness of sheet metal for electrical enclosures – aluminum, copper, or brass

Without supporting frame ^a		With supporting frame or equivalent reinforcing ^a						
Maximum width ^b		Maximum length ^c		Maximum width ^b		Maximum length		Minimum thickness inches (mm)
Inches	(cm)	Inches	(cm)	Inches	(cm)	Inches	(cm)	
3.0	(7.6)	Not limited		7.0	(17.8)	Not limited		0.023
3.5	(8.9)	4.0	(10.2)	8.5	(21.6)	9.5	(24.1)	(0.58)
4.0	(10.2)	Not limited		10.0	(25.4)	Not limited		0.029
5.0	(12.7)	6.0	(15.2)	10.5	(26.7)	13.5	(34.2)	(0.74)
6.0	(15.2)	Not limited		14.0	(35.6)	Not limited		0.036
6.5	(16.5)	8.0	(20.3)	15.0	(38.1)	18.0	(45.7)	(0.91)
8.0	(20.3)	Not limited		19.0	(48.3)	Not limited		0.045
9.5	(24.1)	11.5	(29.2)	21.0	(53.3)	25.0	(63.5)	(1.14)
12.0	(30.5)	Not limited		28.0	(71.1)	Not limited		0.058
14.0	(35.6)	16.0	(40.6)	30.0	(76.2)	37.0	(94.0)	(1.47)
18.0	(45.7)	Not limited		42.0	(106.7)	Not limited		0.075
20.0	(50.8)	25.0	(63.5)	45.0	(114.3)	55.0	(139.7)	(1.91)
25.0	(63.5)	Not limited		60.0	(152.4)	Not limited		0.095
29.0	(73.7)	36.0	(91.4)	64.0	(162.6)	78.0	(198.1)	(2.41)
37.0	(94.0)	Not limited		87.0	(221.0)	Not limited		0.122
42.0	(106.7)	53.0	(134.6)	93.0	(236.2)	114.0	(289.6)	(3.10)
52.0	(132.1)	Not limited		123.0	(312.4)	Not limited		0.153
60.0	(152.4)	74.0	(188.0)	130.0	(330.2)	160.0	(406.4)	(3.89)

^a A supporting frame is a structure of angle or channel or a folded rigid section of sheet metal that is rigidly attached to and has the same outside dimensions as the enclosure surface and that has torsional rigidity to resist the bending moments that shall be applied via the enclosure surface when it is deflected. Construction that is determined to have equivalent reinforcing shall be accomplished by designs that produces a structure that is as rigid as one built with a frame of angles or channels. Construction determined to be without supporting frame includes single sheet with single formed flanges (formed edges), a single sheet which is corrugated or ribbed, and an enclosure surface loosely attached to a frame, for example, with spring clips.

^b The width is the smaller dimension of a rectangular sheet metal piece that is part of an enclosure. Adjacent surfaces of an enclosure shall have supports in common and be made of a single sheet.

^c For a panel that is not supported along one side, for example, side panels of boxes, the length of the unsupported side shall be limited to the dimensions specified unless the side in question is provided with a flange at least 1/2 inch (12.7 mm) wide.

28.1.9 Sheet metal to which a wiring system is to be connected in the field shall have a thickness not less than 0.032 inch (0.81 mm) when uncoated steel, not less than 0.034 inch (0.86 mm) when galvanized steel, and not less than 0.045 inch (1.14 mm) when nonferrous.

28.1.10 When threads for the connection of conduit are tapped through a hole in an enclosure wall, or when an equivalent construction is employed, there shall be not less than three or more than five threads in the metal, and a conduit bushing shall be attached as intended. When threads for the connection of conduit are not tapped all the way through a hole in an enclosure wall or conduit hub, there shall be not less than 3-1/2 threads in the metal and there shall be a smooth, rounded inlet hole for the conductors which:

- a) Shall afford protection to the conductor equivalent to that provided by a standard conduit bushing; and
- b) Shall have an internal diameter the same as that of the corresponding trade size of rigid conduit.

28.1.11 A knockout in a sheet metal enclosure shall be secured in place, and shall be capable of being removed without deformation of the enclosure to the extent that results in damage to electrical components or reduction in electrical spacing. See 28.1.12.

28.1.12 A knockout or hole for connection of conduit shall be provided with a flat surrounding surface for seating of a conduit bushing and shall be located so that installation of a bushing at any knockout or opening used during installation does not result in reduction of spacings between uninsulated live parts and the bushing to less than those required by this standard.

28.1.13 In measuring a spacing between an uninsulated live part and a bushing installed in a knockout, it is to be assumed that a bushing is in place, in conjunction with a single locknut installed on the outside of the enclosure.

28.1.14 A steel enclosure shall resist corrosion by metallic or nonmetallic coatings, such as plating or painting.

28.2 Mechanical protection

28.2.1 Moving parts, such as fan blades, blower wheels, pulleys, or belts, which results in injury to persons shall be enclosed or guarded so that the minor dimension of any opening does not exceed the values indicated in 28.2.3. Parts required for guarding shall be secured by means dependent upon tools for removal unless functioning of the fireplace requires the guard to be in place. Also see 52.20.

28.2.2 Louvers and other openings in the enclosure shall be constructed and located to reduce the risk of unintentional contact with moving parts which results in injury to persons. In determining compliance with these requirements, parts such as covers, panels or grilles used as part of the enclosure are to be removed unless tools are required for their removal.

28.2.3 The distance from an opening to the moving part shall be as indicated in Table 28.3, the minor dimension of the opening shall not, in any case, exceed 1 inch (25.4 mm). For an opening having a minor dimension intermediate between two of the values included in the table, the distance from the opening to the moving part shall be not less than that found by appropriate interpolation between the corresponding values in the right column of the table. The minor dimension of the opening is to be determined by the largest hemispherically tipped cylindrical probe that is capable of being inserted through the opening with a force of 5 pounds (22.3 N).

Table 28.3
Dimensions of openings in enclosure

Minor dimensions of openings ^a		Minimum distance from opening to moving part	
Inches	(mm)	Inches	(mm)
1/4	6.4	1/2	12.7
3/8	9.5	1-1/2	38.1
1/2	12.7	2-1/2	63.5
3/4	19.1	4-1/2	114.0
1	25.4	6-1/2	165.0

^a Openings less than 1/4 inch (6.4 mm) are not to be determined.

28.2.4 A moving part is not to be evaluated in determining compliance with 28.2.1 when:

- a) The part is incapable of being contacted through the opening because of the location of fixed components, including baffles;
- b) The part is made inoperative, when exposed, through the use of interlocking devices; or
- c) The blower assembly must be withdrawn from the enclosure of the fireplace to expose the moving part.

28.3 Electrical protection

28.3.1 Louvers and other openings in the enclosure shall be constructed and located to reduce the risk of unintentional contact with uninsulated live parts. In determining compliance with this requirement, parts such as covers, panels and grilles used as part of the enclosure are to be removed unless tools are required for their removal or an interlock is provided.

28.3.2 Uninsulated high-voltage live parts shall be located, guarded or enclosed in compliance with the requirements of 28.3.3 – 28.3.5.

28.3.3 An opening in the enclosure of the product that does not have an entrance of a 1 inch (25.4 mm) diameter rod is required when a probe as illustrated in Figure 28.1, inserted into the opening, is not capable of being made to touch any part that involves the risk of electric shock.

28.3.4 With respect to the requirement of 28.3.3, the probe is to be articulated into any configuration and is to be rotated or angled to any position before, during or after insertion into the opening, and the penetration is to be to any depth intended by the opening size, including minimal depth combined with maximal articulation.

28.3.5 An opening in an enclosure, as illustrated in Figure 28.2, that where an entrance of a 1 inch (25.4 mm) diameter round rod is required when, within the enclosure, there is no uninsulated live part or film-coated wire less than R distance from the inside edge of the perimeter of the opening and X distance from the plane of the opening. T equals the enclosure thickness, R equals X minus T, and X equals five times the diameter of the largest round rod that is capable of being inserted through the opening and not less than 6-1/16 inches (154 mm).

Figure 28.1
Accessibility probe

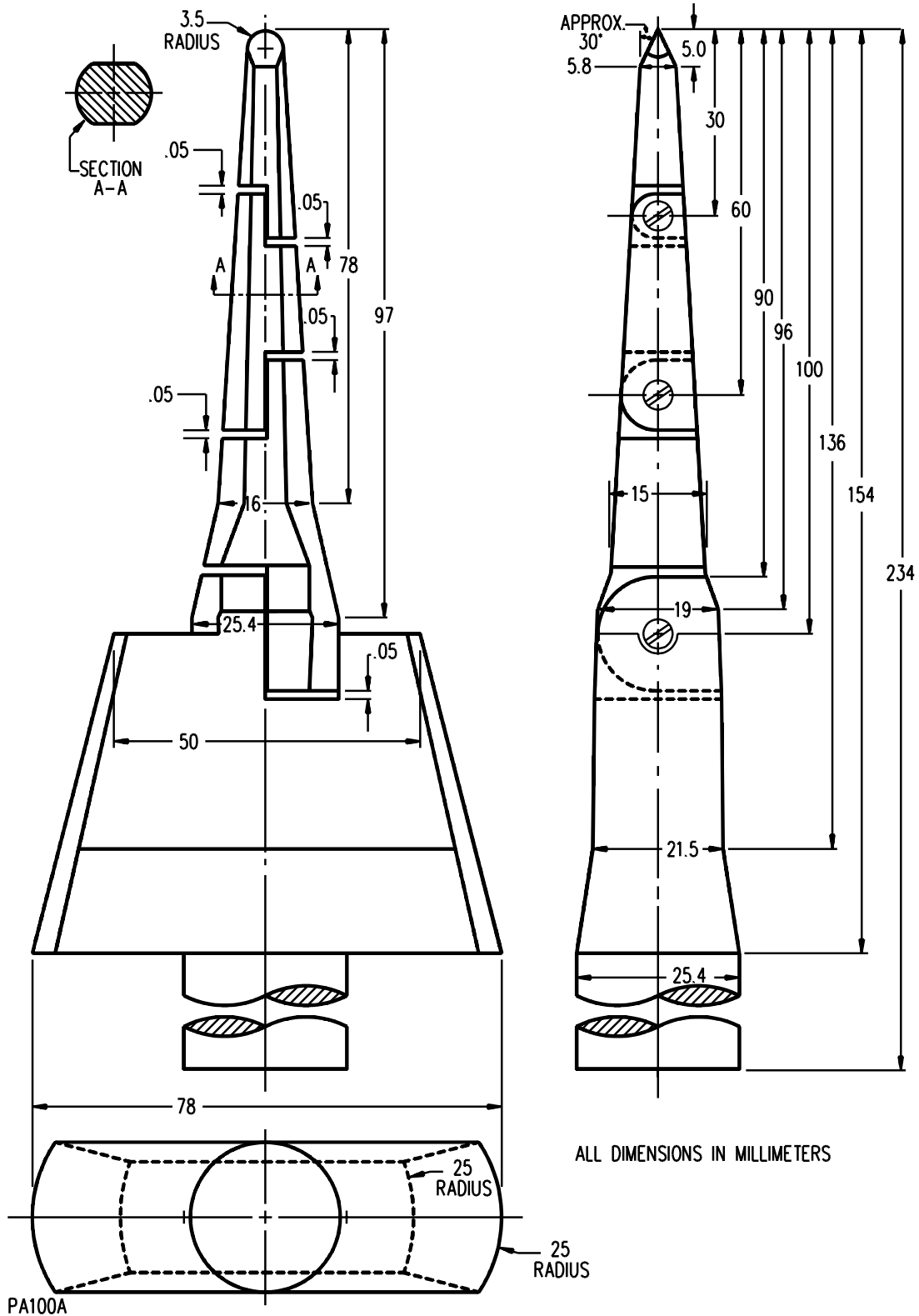
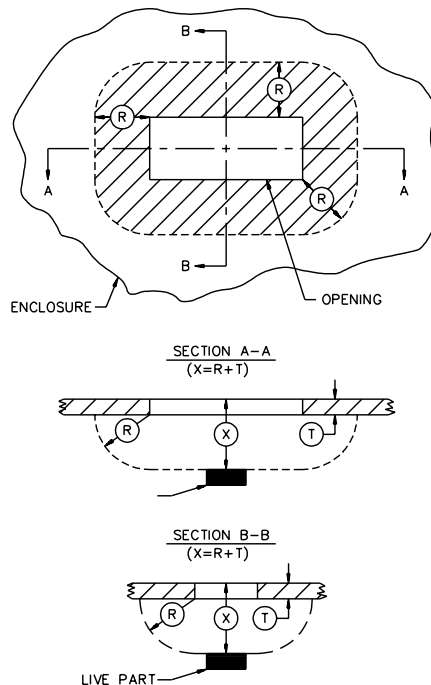

Figure 28.2
Opening in enclosure



SB0610-1

28.3.6 In addition to the requirements of 28.3.2 – 28.3.5, uninsulated live parts inside the enclosure that are capable of being contacted by persons performing operations such as replacing fuses, resetting manual-reset devices, replacing air filters, oiling motors, or other such service operations shall be located, guarded or enclosed to reduce the risk of contact unless tools are required to expose the live part. See 52.20.

28.3.7 A fuseholder shall be constructed, installed or guarded so that adjacent uninsulated high-voltage live parts, other than the screw shell of a plug fuseholder, cartridge fuse clips or wiring terminals to the fuseholder, shall not be exposed to contact by persons removing or replacing fuses. A barrier of vulcanized fiber or similar material employed as a guard for uninsulated high-voltage live parts shall be not less than 1/32 inch (0.8 mm) thick. A separation of less than 4 inches (102 mm) is to be identified as adjacent.

28.4 Doors and covers

28.4.1 Service covers or panels in the outer enclosure shall require the use of tools for removal or shall be provided with an interlocking mechanism when they give access to unenclosed uninsulated live parts or moving parts that result in injury to persons.

28.4.2 An interlocking mechanism that must be engaged in the closed position of the cover before parts are energized and secures the cover in the closed position when engaged is evaluated to comply with the requirements in 28.4.1.

28.4.3 A hinged panel or cover shall be positioned or arranged so that when it is in an open position it is not subjected to falling or swinging due to gravity or vibration so as to result in risk of injury to persons from the panel or cover, moving parts, or risk of electric shock from uninsulated live parts.

28.4.4 The assembly shall be arranged so that an overcurrent protective device is capable of being placed or reset without removing parts other than a service cover(s) or panel(s), and the cover or door enclosing the device.

28.4.5 A required protective device shall be inaccessible from outside the enclosure without requiring the opening of a door or cover.

Exception: The operating handle of a circuit breaker, the reset button of a manually resettable motor protector, and similar parts are not prohibited from projecting outside the enclosure.

28.4.6 An opening in an outer enclosure around a handle, reset button, or other control member unless the clearance between the control member and the edge of the opening is not more than 1/8 inch (3.2 mm) for any setting or position of the control member.

28.4.7 Covers for enclosure of fuses in high-voltage circuits shall be hinged, see 28.4.8. Covers for manual-reset overload protective device enclosures shall be hinged when it is required to open the cover to reset the device.

Exception: A hinged cover is not required for extractor type fuses.

28.4.8 A hinged cover shall not depend solely upon screws or other similar means to hold it closed, and shall be provided with a latch or the equivalent. A cover interlocking mechanism as described in 28.4.2 is capable of being used as the sole means for securing the cover or panel.

28.4.9 A spring latch, a magnetic latch, a dimple, or any other mechanical arrangement that holds the door in place and requires some effort on the user's part to open it is identified to be a means for holding the door in place as required in 28.4.1.

28.4.10 A door or cover giving direct access to fuses in other than low-voltage circuits shall shut closely against a 1/4 inch (6.4 mm) rabbet or shall have either turned flanges for the full length of four edges or angle strips fastened to it. Flanges or angle strips shall fit closely with the outside of the wall of the box and shall overlap the edges of the box not less than 1/2 inch (12.7 mm). Constructions include construction such as a fuse enclosure located within an outer enclosure or a flange and rabbet combination which affords the equivalent protection.

29 Mounting of Electrical Components

29.1 A switch, an attachment-plug receptacle, a strain relief bushing, or similar component shall be secured in position and shall be prevented from turning. See 29.4. See 29.2 and 29.3 for Exception.

29.2 The requirement that a switch be prevented from turning is not required when all of the following conditions are met:

- a) The switch is of a plunger or other type that does not tend to rotate when operated. A toggle switch is identified to be subject to forces that tend to turn the switch during the operation of the switch;
- b) Means of mounting the switch make it so that operation of the switch does not loosen it;
- c) The spacings are not reduced below the minimum required values when the switch rotates;
- d) Operation of the switch is by mechanical means rather than direct contact by persons.

29.3 A lampholder of a type in which the lamp is not capable of being replaced, such as a neon pilot or indicator light in which the lamp is sealed in a nonremovable jewel, is not required to be prevented from turning when rotation does not reduce spacings below the minimum required values. See Spacings, Section 41.

29.4 The means for preventing rotation specified in 29.1 shall consist of more than friction between surfaces. A toothed lock washer that provides both spring take-up and an interference lock is capable of being used as means for preventing the turning of a small stem-mounted switch or other device having a single-hole mounting means.

29.5 An uninsulated current-carrying part and a part that supports a live part shall be secured to the base or mounting surface so that it is prevented from turning or shifting in position when such motion results in a reduction of spacings below the minimum required values. See Spacings, Section 41. Friction between surfaces shall not be relied on as a means to prevent shifting or turning of a live part, and a lock washer as described in 29.4 is capable of being used.

29.6 Flammable or electrically conductive thermal or acoustical insulation shall not contact uninsulated live parts.

30 Field-Installed Blower Assemblies

30.1 A fireplace having provision for the use of a blower assembly to be attached in the field shall be constructed so that the use of the assembly does not introduce a risk of fire, electric shock, or contact with moving parts that results in injury to persons.

30.2 The fireplace shall comply with the requirements of this standard with and without the field-installed blower assembly installed.

30.3 Installation of the field-installed blower assembly by the user shall be restricted to an arrangement that is capable of being accomplished by means of receptacles and plug-in connectors.

Exception: Low-voltage accessories shall not be connected by other means unless the installation does not require rearrangement of components or wiring, cutting or splicing of existing wiring, or soldered connections.

30.4 The installation of a field-installed blower assembly by service personnel shall be by means of receptacles, plug-in connectors, insulated wire connectors, or by connection to existing wiring terminals.

30.5 With reference to the requirements in 30.4, any installation shall not require the cutting of wiring or the soldering of connections by the installer. Installations shall not require cutting, drilling or welding in electrical enclosures or in other areas where such operations damage electrical or fireplace components and wiring within the enclosure.

30.6 Strain-relief means shall be provided for the wiring in the field-installed blower assembly when stress is transmitted to the terminal connections during installation.

30.7 All terminals and wiring intended to be field connected shall be identified on the field-installed blower assembly, on the fireplace when connections are made between the blower assembly and the fireplace, and on the wiring diagram(s).

30.8 Except where it is obvious, the mounting location of the field-installed blower assembly shall be indicated on the fireplace. When the mounting location is obvious due to the function of the blower assembly and arrangement of the fireplace, and instructions are provided covering the installation and location for the blower assembly, the mounting location of the blower assembly are not required to be indicated on the fireplace.

30.9 All mounting brackets, supports, and fasteners required to install the blower assembly shall be provided with the blower or as part of the fireplace.

30.10 As part of the investigation, the blower assembly is to be trial-installed to determine that its installation is capable, that the instructions are detailed and accurate, and that the use of the blower assembly does not introduce a risk of electric shock or unintentional contact with moving parts that result in injury to persons.

31 Field Supply Connections

31.1 Fireplaces shall have provision for permanent connection to the power supply.

31.2 As described in 31.3 – 31.16, field wiring terminals are determined to be the terminals to which power supply, control, or equipment grounding connections are made in the field when the fireplace is installed as intended.

31.3 A blower assembly shall have provision for connection of one of the wiring systems that are required for it in accordance with the National Electrical Code, ANSI/NFPA 70-1996.

31.4 The location of the field supply connections terminal box or compartment shall be such that inspection of the wiring is possible after installation. The connections shall be accessible without removing parts other than a service cover or panel and the cover of the outlet box or compartment in which the connections are made.

31.4 revised January 13, 1999

31.5 Space shall be provided in the field wiring compartment or outlet box for installation of the number and size of conductors required in the installation, when at least 6 inches (150 mm) length of each conductor is brought into the wiring compartment. A trial installation using three No. 12 AWG, Type THW conductors and all clamps and receptacles is to be made to determine compliance with these requirements.

31.6 A terminal compartment intended for the connection of a supply raceway shall be secured in position and shall not turn under conditions of intended use.

31.7 A blower assembly shall be provided with field wiring terminals for the connection of field wiring conductors of at least the size required by the National Electrical Code, ANSI/NFPA 70-1996, corresponding to the rating of the assembly or with leads not less than 6 inches (152 mm) long except as noted in 31.17. It is assumed that branch circuit conductors rated 60°C (140°F) are used.

31.8 A field wiring terminal shall be prevented from turning or shifting in position by means other than friction between surfaces. This is accomplished by means such as two screws or rivets; by square shoulders or mortices; by a dowel pin, lug, or offset; or by a connecting strap or clip fitted into an adjacent part.

31.9 For No. 8 AWG (8.4 mm²) and larger conductors, pressure wire connectors shall be used. For No. 10 AWG (5.3 mm²) and smaller conductors, the parts to which wiring connections are made consist of pressure wire connectors, clamps or wire binding screws with cupped washers, terminal plates, or the equivalent to hold the wire in position.

31.10 A wire binding screw at a field wiring terminal shall be not smaller than No. 10 (4.8 mm diameter).

Exception: A No. 8 (4.2 mm diameter) screw is to be used for the connection of one No. 14 AWG (2.1 mm²) and a No. 6 (3.5 mm diameter) screw is to be used for the connection of a No. 16 AWG (1.3 mm²) or No. 18 AWG (0.82 mm²) control circuit conductor.

31.11 It shall be noted that according to the National Electrical Code, ANSI/NFPA 70-1996, No. 14 AWG (2.1 mm²) is the smallest conductor which the installer uses for branch circuit wiring and thus is the smallest conductor that is anticipated at a terminal for the connection of a power supply wire.

31.12 A terminal plate for a wire binding screw shall be of metal not less than 0.030 inch (0.76 mm) thick for a No. 14 AWG (2.1 mm²) or smaller wire and not less than 0.050 inch (1.27 mm) thick for a wire larger than No. 14 AWG. In either case, there shall be not less than two full threads in the metal.

31.13 A terminal plate formed from stock having the minimum required thickness shall have the metal extruded at the tapped hole for the binding screw to provide two full threads.

Exception: Two full threads are not required when a lesser number of threads results in a connection in which the threads do not strip with tightening torque in accordance with the values indicated in the Standard for Wire Connectors and Soldering Lugs for Use with Copper Conductors, UL 486A.

31.14 Uprturned lugs or a cupped washer shall be able to retain a conductor of the size used for the field wiring leads under the head of the screw or the washer. A conductor used for the field wiring leads shall be not smaller than No. 14 AWG (2.1 mm²).

31.15 A wire binding screw shall thread into metal.

31.16 A field wiring terminal intended for the connection of a grounded conductor shall be of a metal, or plated with a metal, substantially white in color and shall be readily distinguishable from the other terminals, or correct identification of that terminal shall be shown in some other manner, such as on an attached wiring diagram. A lead intended for the connection of a grounded conductor shall be finished to show a white or natural gray color, shall be readily distinguishable from other leads, and no other lead shall be so identified.

31.17 The length of a lead inside an outlet box or wiring compartment shall be 6 inches (152 mm) or more when the lead is intended for field connection to an external circuit.

Exception: The lead shall not be less than 6 inches (152 mm) in length unless it is evident that the use of a longer lead results in a risk of fire or electric shock.

No Text on This Page

31.18 Leads intended for connection to an external circuit shall be provided with strain relief when stress on the lead is transmitted to terminals, splices or internal wiring. See Strain Relief Test, Section 48.

31.19 Leads provided for spliced connections to an external high-voltage circuit shall not be connected to wire binding screws or pressure wire connectors located in the same compartment as the splice unless the screws or connectors are rendered unusable for field wiring connections or the leads are insulated at the unconnected ends.

32 Grounding

32.1 A grounding means shall be provided for all equipment containing parts which require grounding, see Bonding for Grounding, Section 35.

32.2 An equipment grounding terminal is identified to constitute means for grounding.

32.3 The equipment grounding terminal shall be able to secure a conductor of the size required for the particular application in accordance with the National Electrical Code, ANSI/NFPA 70-1996.

32.4 A soldering lug, a push-in connector, a screwless connector, or a quick-connect or similar friction fit connector shall not be used for the grounding terminal intended for the connection of field supply connections or for the grounding wire in a supply cord.

32.5 A wire binding screw intended for the connection of an equipment grounding conductor shall have a green-colored head that is hexagonal, slotted or both. A pressure wire connector intended for connection of such a conductor shall be plainly identified by being marked "G," "GR," "GROUND" or "GROUNDING," the grounding symbol illustrated in Figure 32.1, or by a marking on a wiring diagram provided on the fireplace. The wire binding screw or pressure wire connector shall be secured to the frame or enclosure of the fireplace and shall be located so that it is not removed during intended service operations such as replacing fuses, resetting manual-reset devices or oiling motors. The wire binding screw or pressure wire connector shall be provided with a cupped head or cupped washer, or equivalent, of a size adequate to retain the equipment grounding conductor in place.

32.5 revised February 24, 1997

Figure 32.1
Grounding symbol

Figure 32.1 revised January 26, 1998

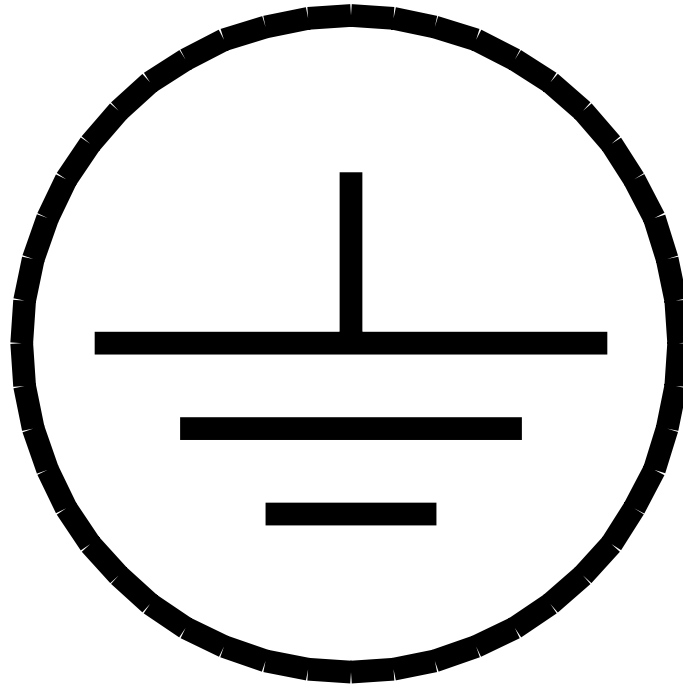

32.6 When a pressure wire connector intended for grounding is located where it is capable of being mistaken for a neutral conductor of a grounded supply, it shall be identified by a marking EQUIPMENT GROUND or with a green color identification or both.

33 Internal Wiring

33.1 General

33.1.1 For the purpose of these requirements, internal wiring is identified to be all the interconnecting wiring beyond the wiring terminals or the leads intended for field wiring connections.

33.1.2 The internal wiring of a blower assembly shall consist of wires of adequate size for the particular application when evaluated with respect to:

- a) The temperature and voltage to which the wiring is subjected;
- b) Its exposure to oil or grease; and
- c) To other conditions of service to which it is subjected.

A conductor other than an integral part of a component shall be not smaller than No. 18 AWG (0.8 mm²).

33.1.3 There is no temperature limit applicable to a conductor (except as noted in Table 10.1) provided with beads of noncarbonizable material or the equivalent.

33.1.4 Insulated wire employed for internal wiring shall be standard building wire, fixture wire, flexible cord, or appliance wiring material adequate for the particular application as described by these requirements.

33.1.5 Wire types intended for internal wiring include rubber insulated conductors, such as Types RH, RHH, and RHW; and thermoplastic insulated conductors, such as Types TW, THHN, THW, THWN, and MTW.

33.1.6 Fixture wires intended for internal wiring include rubber insulated conductors, such as Types RFH-2, SF-2, SFF-2, FF-2, and FFH-2; and thermoplastic insulated conductors, such as Types TF, TFF, TFN, and TFFN.

33.1.7 Flexible cords intended for internal wiring include Types HPN, HS, HSJ, HSJO, HSO, S, SJ, SJO, SJT, SJTO, SO, ST, STO, SP-2, SP-3, SPT-2, and SPT-3.

33.1.8 Appliance wiring material having thermoplastic insulation not less than 2/64 inch (0.8 mm) thick for Nos. 18 – 10 AWG (0.82 – 5.3 mm²), 3/64 inch (1.2 mm) thick for No. 8 AWG (8.3 mm²), and 4/64 inch (1.6 mm) thick for Nos. 6 – 2 AWG (13.3 – 33.6 mm²) is capable of being used for internal wiring.

33.1.9 Appliance wiring material having rubber, neoprene, or thermoplastic insulation with properties equivalent to the jacket of Types SJ, SJO, SJTO, or SJT cord, with an insulation thickness not less than 4/64 inch (1.59 mm) for Nos. 18 – 16 AWG (0.82 – 1.31 mm²), 5/64 inch (1.93 mm) for Nos. 14 – 10 AWG (2.08 – 5.3 mm²), is capable of being used for internal wiring (see 33.2.6).

33.1.10 Parallel-conductor appliance wiring material of the integral type shall be ripped not more than 3 inches (76 mm) unless the minimum wall thickness of the conductor insulation after ripping is at least 0.058 inch (1.47 mm). When the material has conductor insulation not less than 0.028 inch (0.71 mm) after ripping and is within a separate metal enclosure, the length of rip is not limited.

33.2 Methods

33.2.1 The wiring and connections between separate sections of a blower assembly shall be mechanically protected or enclosed.

33.2.2 Internal wiring that is exposed through an opening in the enclosure of a fireplace is identified to be protected as required in 33.2.1 when evaluated as though it were film coated wire, the wiring complies with the requirements in 28.3.1 – 28.3.5. Internal wiring within an enclosure is required even though it is not capable of being touched with the probe, when it is protected or guarded so that it is not capable of being grasped or hooked in a manner that subjects the wire to stress.

33.2.3 When the wiring of a blower assembly is located so that it is in proximity to combustible material or is subjected to mechanical damage, it shall be in metal-clad cable, rigid metal conduit, electrical metallic tubing, metal raceway, or shall otherwise be protected.

33.2.4 Except as indicated in 33.2.5 and 33.2.6, wiring in a compartment through which air, to or from the heated space, is circulated shall be in metal-clad cable, rigid metal conduit, flexible metal conduit, electrical metallic tubing, metal raceway, or shall otherwise be protected.

33.2.5 Lengths not exceeding 4 inches (102 mm), except as noted in 33.2.6, of unenclosed wiring of the types specified in 33.1.5, 33.1.6, and 33.1.8, or equivalent, shall be employed unless they are enclosed within the unit enclosure and when they are supported to prevent damage from air movement.

UL Copyright Material

Not Authorized for Further Reproduction or Distribution without Permission from UL

No Text on This Page

33.2.6 Flexible cords, as specified in 33.1.7, or equivalent appliance wiring material (see 33.1.9) without limitation on length, is to be employed when protected as described in 33.2.5.

33.2.6 revised January 13, 1999

33.2.7 Wiring shall be protected from sharp edges (including male screw threads), burrs, fins, moving parts, and other features that abrade the insulation on conductors. Clamping means shall have smooth, rounded surfaces.

33.2.8 A hole in a sheet metal wall within the overall enclosure of a blower assembly, through which insulated wires pass, shall be provided with a smooth, rounded bushing or shall have smooth, rounded surfaces upon which the wires bear, to prevent abrasion of the insulation. Bushings shall be fabricated from materials such as ceramic, phenolic, cold molded composition or fiber. A flexible cord used for external interconnection as specified in 33.2.1, shall be provided with bushings and strain relief in accordance with 33.2.10 – 33.2.13, unless the construction is such that the cord is protected from stress or motion.

33.2.9 Insulated wires are not prohibited from being bunched and passed through a single opening in a metal wall within the enclosure of a blower assembly.

33.2.10 Strain relief shall be provided to prevent a mechanical stress on a flexible cord from being transmitted to terminals or splices.

33.2.11 Means shall be provided to prevent the flexible cord or lead from being pushed into the enclosure through the cord-entry hole when such displacement results in:

- a) Stress being transmitted to terminals, splices, or other internal wiring;
- b) Live uninsulated parts being contacted;
- c) Reducing the spacings within the enclosure;
- d) The cord being subjected to damage from moving parts or to temperatures greater than its temperature rating, when moved inward; or
- e) Subjecting the supply cord, lead, or other internal connections or components to mechanical damage.

To determine compliance, the supply cord or lead shall be tested in accordance with Section 48A, Push-Back Relief Test.

Revised 33.2.11 effective May 17, 1999

33.2.12 At a point where a flexible cord passes through an opening in a wall, barrier, or enclosing case, there shall be a bushing or the equivalent secured in place, and the bushing shall have a smooth, rounded surface against which the cord bears. The heat and moisture resistant properties of the bushing material shall be capable of being used for the particular application.

33.2.13 A smoothly rounded hole in the wall or barrier is capable of being used in lieu of a separate bushing.

33.2.14 A splice or connection shall be mechanically secure. A soldered connection shall be made mechanically secure before being soldered.

33.2.15 A splice shall be located within the unit enclosure. It shall be secured to a fixed member or located in a separate enclosure when it is subjected to flexing motion or vibration due to air movement or shall be moved during service operations, such as replacing fuses or oiling motors.

33.2.16 A splice shall be provided with electrical insulation equivalent to that of the conductors when spacings between the splice and other metal parts are not capable of being maintained. Thermoplastic tape wrapped over sharp ends of wires shall not be provided to meet this requirement.

33.2.17 The means of connecting stranded internal wiring to a wire binding screw shall prevent loose strands of wire from contacting other live parts that are not always of the same polarity as the wire and from contacting dead metal parts. This is accomplished by use of pressure terminal connectors, soldering lugs, crimped eyelets, soldering all strands of the wire, or other similar means.

33.2.18 A splicing device such as a pressure-type wire connector shall not be employed unless it complies with the Standard for Wire Connectors and Soldering Lugs for Use With Copper Conductors, UL 486A.

33.2.19 A quick-connecting assembly shall form a secure electrical connection, such as by detents in the mating parts, and shall be rated for the current involved. Securement of connections is to be determined by engagement/disengagement tests as specified in the Standard for Electrical Quick-Connect Terminals, UL 310.

34 Separation of Circuits

34.1 Unless provided with insulation rated for the highest voltage involved, insulated conductors of different circuits, for example, internal wiring that includes wires in a wiring compartment, shall be separated from each other by barriers or shall be physically segregated, and shall be separated or segregated from uninsulated live parts connected to different circuits.

34.2 Segregation of insulated conductors shall be accomplished by clamping, routing or other means to provide for separation from insulated or uninsulated live parts of a different circuit.

34.3 Field-installed conductors of any circuit shall be either segregated or separated by barriers from field-installed and factory-installed conductors connected to any other circuit, unless the conductors of both circuits are insulated for the maximum voltage of either circuit.

34.4 Except at wiring terminals, field-installed conductors of a high-voltage circuit or a low-voltage circuit with Class 1 National Electrical Code, ANSI/NFPA 70-1996, wiring shall be segregated or separated by barriers as follows:

- a) From uninsulated live parts connected to a different circuit; and
- b) From any uninsulated live parts of electrical components, such as a motor overload protective device, or other protective device, where short-circuiting or grounding result in impaired operation of the fireplace.

34.5 Field-installed conductors of a low-voltage circuit with Class 2 National Electrical Code, ANSI/NFPA 70-1996, wiring shall be segregated or separated by barriers as follows:

- a) From uninsulated live parts connected to a high-voltage circuit; and
- b) From wiring terminals and any other uninsulated live parts of low-voltage electrical components, such as a motor overload protective device, or other protective device, where short-circuiting or grounding results in operation of the fireplace that increases the risk of fire or electric shock.

34.6 When a barrier is used to provide separation between the wiring of different circuits, it shall be of metal or of a rigid insulating material secured in place.

35 Bonding for Grounding

35.1 Exposed or accessible noncurrent-carrying metal parts that become energized, and that are contacted by the user or by service personnel during service operations that is performed while the equipment is energized, shall be electrically connected to the point of connection of an equipment ground.

35.2 Except as indicated in 35.3, uninsulated metal parts of cabinets, electrical enclosures, motor frames and mounting brackets, controller mounting brackets, capacitors and other electrical components are to be bonded for grounding when they are contacted by the user or serviceman.

No Text on This Page

35.3 The following metal parts are not required to be grounded:

- a) Adhesive-attached metal-foil markings, screws or handles that are located on the outside of enclosures or cabinets and isolated from electrical components or wiring by grounded metal parts.
- b) Isolated metal parts, such as magnet frames and armatures or small assembly screws that are separated from wiring and uninsulated live parts.
- c) Panels and covers that do not enclose uninsulated live parts, when insulated parts and wiring are separated from the panel or cover.
- d) Panels and covers that are insulated from electrical components and wiring by an attached insulating barrier of vulcanized fiber, varnished cloth, phenolic composition, or similar material not less than 1/32 inch (0.8 mm) thick.

35.4 When a component, such as a switch, becomes separated from its intended grounding means for purposes of testing or adjustment while the equipment is energized, it is to be provided with a grounding conductor not requiring removal for such service.

35.5 Splices shall not be employed in wire conductors used for bonding.

35.6 Metal-to-metal hinge bearing members are capable of being used as a means for bonding a door for grounding.

35.7 A separate bonding conductor shall be of material rated for use as an electrical conductor. Ferrous metal parts in the grounding path shall be protected against corrosion by enameling, galvanizing, plating, or equivalent means. A separate bonding conductor or strap shall:

- a) Be protected from mechanical damage, such as by being located within the confines of the outer enclosure or frame; and
- b) Not be secured by a removable fastener used for any purpose other than bonding for grounding, unless the bonding conductor is not omitted after removal and replacement of the fastener.

35.8 The bonding shall be by a positive means, such as by clamping, riveting, bolted or screwed connection, or by welding, soldering, or brazing with materials having a softening or melting point greater than 454°C (850°F). The bonding connection shall penetrate nonconductive coatings, such as paint or vitreous enamel. Bonding around a resilient mount shall not depend on the clamping action of rubber or similar material, except as indicated in 35.10.

35.9 A bolted or screwed connection that incorporates a star washer or serrations under the screwhead is capable of being used to penetrate nonconductive coatings where required for compliance with the requirements in 35.8.

35.10 A connection shall not depend upon the clamping action exerted by rubber or similar materials unless it complies with the requirements in 35.12 under any degree of compression that meets the requirement of a variable clamping device, and unless the results comply after exposure to the effects of oil, grease, moisture, and thermal degradation occurs in service. The effect of assembling and disassembling such a clamping device for maintenance purposes is to be identified with respect to the capability of the clamping device being reassembled in its intended position.

35.11 When bonding depends on screw threads, two or more screws or two full threads of a single screw shall engage the metal.

35.12 When the adequacy of a bonding connection is not capable of being determined by examination, or when a bonding conductor is smaller than required by 35.13 – 35.15, it shall be evaluated to determine that the connecting means does not open while carrying for 2 minutes twice the current equal to the rating of the branch circuit overcurrent device required to protect the equipment.

35.13 The size of a conductor or strap employed to bond an electrical enclosure or motor frame shall be based on the rating of the branch circuit overcurrent device to which the equipment is connected. Except as indicated in 35.12, the size of the conductor or strap shall be in accordance with Table 35.1.

Table 35.1
Bonding wire conductor size

Rating of overcurrent device, amperes	Size of bonding conductor ^a			
	Copper wire		Aluminum wire	
	AWG	(mm ²)	AWG	(mm ²)
15	14	2.1	12	3.3
20	12	3.3	10	5.3
30	10	5.3	8	8.4

^a Or equivalent cross-sectional area.

35.14 A bonding conductor to a component or electrical enclosure is not required to be larger than the size of the conductors supplying power to the component or components within the enclosure.

35.15 All exposed dead metal parts that become energized shall be electrically connected to the bonding conductor of the power supply cord(s).

36 Capacitors

36.1 A motor starting or running capacitor shall be housed within an enclosure or container to reduce the risk of mechanical damage of the plates, and the emission of flame or molten material resulting from malfunction of the capacitor. The container shall be of metal providing the strength and protection not less than that of uncoated steel having a thickness of 0.020 inch (0.51 mm). See 36.2 for Exception.

36.2 The individual container of a capacitor shall be of sheet metal having a thickness less than that specified in 36.1 or shall be of material other than metal when the capacitor is mounted within the enclosure of the blower assembly or within an enclosure that houses other parts of the blower assembly.

36.3 When the container of an electrolytic capacitor is metal, the container shall be identified as a live part and shall be provided with moisture-resistant electrical insulation to isolate it from dead metal parts and to reduce the risk of a person contacting it during servicing operations. The insulating material shall be not less than 1/32 inch (0.8 mm) thick.

36.4 A capacitor employing a liquid dielectric medium more combustible than askarel shall be protected against expulsion of the dielectric medium when tested in accordance with the applicable performance requirements of this standard, including faulted overcurrent conditions based on the circuit in which it is used. See Short-Circuit Test, Section 49.

Exception: When the available fault current is limited by other components in the circuit, such as a motor start winding, the capacitor is tested using a fault current less than the test current specified in Table 49.1 and not less than the current established by dividing the circuit voltage by the impedance of the other component(s).

37 Insulating Material

37.1 Material for the mounting of uninsulated live part shall be porcelain, phenolic composition or other material.

37.2 Vulcanized fiber is not prohibited from being used for insulating bushings, washers, separators, and barriers, and it shall not be used as the sole support for uninsulated live parts where shrinkage, current leakage, or warpage introduces a risk of electric shock. Polymeric materials shall not be used for the sole support of uninsulated live parts when found to have adequate mechanical strength and rigidity, resistance to heat, resistance to flame propagation, dielectric withstand, and other factors involved with conditions of actual service. All of these factors are to be evaluated with respect to thermal aging.

38 Motors and Motor Overcurrent (Overload) Protection

38.1 All motors shall be protected by self-impedance, an integral thermal protector, overcurrent protective devices, or by combinations thereof.

38.2 Overcurrent protective devices as referred to in 38.1 are those complying with the requirements of the National Electrical Code, ANSI/NFPA 70-1996 as follows:

- a) A separate overcurrent device which is responsive to motor current. This device shall be rated or required to trip at no more than the following percent of the motor full-load current rating:

Motors with a marked service factor not less than 1.15	125 percent
Motors with a marked temperature rise not over 40°C	125 percent
All other motors	115 percent

Each winding of a multispeed motor is to be evaluated separately and the motor is to be protected at all speeds.

- b) When the values specified for motor running overcurrent protection do not correspond to the standard sizes or ratings of fuses or magnetic or thermal overload protective devices, the next higher size of rating is used, and not higher than the following percent of motor full-load current rating:

Motors with a marked service factor not less than 1.15	140 percent
Motors with a marked temperature rise not over 40°C	140 percent
All other motors	130 percent

38.3 An integral thermal protective device shall comply with the Standard for Overheating Protection for Motors, UL 2111.

38.3 revised January 26, 1998

38.4 Separate overcurrent devices, except when included as part of a magnetic motor controller, shall be assembled as part of the blower assembly, and be readily identifiable as such after assembly to the fireplace. Such protection shall not include means for manually interrupting the motor circuit when such interruption results in the operation of the blower assembly that increases the risk of fire or electric shock.

38.5 Motors, such as direct-drive fan motors, that are not subjected to overloads and that are determined to be protected against overheating due to locked-rotor current by a thermal or overcurrent protective device shall not be used, unless it is determined that the motor does not overheat under conditions of intended use.

38.6 Impedance protected motors shall comply with the Standard for Motor-Operated Appliances, UL 73.

38.7 Fuses shall not be used as motor overload protective devices unless the motor is acceptably protected by the largest size fuse which are inserted in the fuseholder.

38.8 A fan or blower motor shall be constructed for continuous duty.

38.9 Motors having openings in the enclosure or frame shall be installed or shielded to prevent particles from falling out of the motor onto combustible material located within or under the assembly.

38.10 The requirement in 38.9 shall necessitate the use of a barrier of noncombustible material under an open type motor unless:

a) The structural parts of the motor of the blower assembly such as the bottom closure, provide the equivalent of such a barrier; or

b) The motor overload protection device provided with a single-phase motor is such that no burning insulation or molten material falls to the surface that supports the blower assembly when the motor is energized under each of the following fault conditions, as applicable to the particular type of motor:

- 1) Open main winding;
- 2) Open starting winding;
- 3) Starting switch short-circuited; and
- 4) Capacitor shorted, permanent split capacitor type; or

c) The motor is provided with a thermal motor protector (a protective device that is sensitive to temperature and current) that prevents the temperature of the motor windings from becoming higher than 125°C (257°F) under the maximum load under which the motor shall run without causing the protector to cycle and from becoming higher than 150°C (302°F) with the rotor of the motor locked. See Stalled Motor Test, Section 47.

d) The motor complies with the requirements for impedance-protected motors, and the temperature of the motor winding does not exceed 150°C (302°F) during the first 72 hours of operation with the rotor of the motor locked. See Stalled Motor Test, Section 47.

38.11 The barrier specified in 38.10 shall be horizontal, shall be located as indicated in Figure 38.1, and shall have an area not less than that described in that illustration. Openings for drainage and ventilation shall not be employed in the barrier, unless that, in such openings, there is no molten metal or burning insulation to fall on combustible material.

Figure 38.1
Location and extent of barrier

Figure 38.1 revised January 26, 1998

LOCATION AND EXTENT OF BARRIER

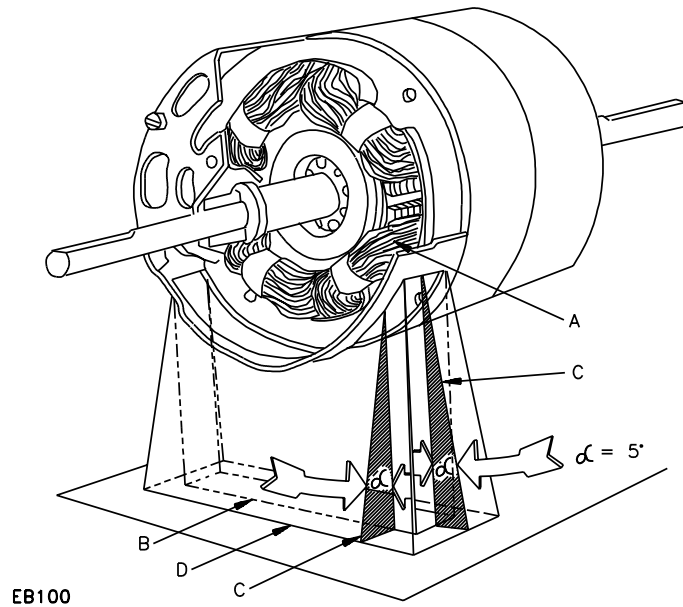

39 Switches and Controllers

39.1 A switch or controller shall have a current, frequency and voltage rating not less than that of the load that it controls when the blower is operated while connected to a supply circuit of rated voltage. The effects of the output waveform of motor speed controllers shall not impair the operation of the motor during all conditions of intended and unintended motor operation.

39.2 A switch subjected to a temperature higher than 65°C (149°F) is to be evaluated with respect to the temperature limitations of the materials employed.

39.3 When a blower assembly is intended to be connected to the conductor of a power supply circuit identified as the grounded conductor, a lampholder with a screw shell base shall be wired so that the screw shell is connected to that conductor.

39.4 A plug fuseholder in a blower assembly intended to be connected to a 120 volt or 120/240 volt, 3-wire circuit shall be wired in an ungrounded conductor with the screw shell connected toward the load.

39.5 A single-pole switching device shall not be connected to the grounded conductor.

39.6 A switch shall be located or protected so that it is not subjected to mechanical damage from items such as logs.

39.7 The opening of a switching device having a marked OFF position or equivalent shall disconnect all ungrounded conductors of the power supply circuit.

40 Transformers

40.1 A power transformer shall have a secondary rating not less than the connected load, except that the load is greater than the marked rating when the temperature of the transformer does not exceed the maximum temperature during the Temperature Test – Electrical Components, Section 45.

40.2 A power transformer that supplies a motor load shall not result in a risk of fire when the motor locks or does not start. A power transformer is identified to comply with this requirement when the primary circuit is protected by an overcurrent device rated or set at not more than 250 percent of the full-load primary current of the transformer.

40.3 A transformer that furnishes power to a low-voltage circuit shall be of the two-coil insulated type.

41 Spacings

41.1 The spacing between field wiring terminals of opposite polarity, and between a wiring terminal and any other uninsulated metal part (dead or live) not of the same polarity, shall be not less than that specified in Table 41.1. See 31.2. See Figure 41.1.

Exception: The spacing requirements in Table 41.1 do not apply to the inherent spacings of a component of a blower assembly, such as a switch. Such spacings shall comply with the requirements for the component in question.

**Table 41.1
Spacings at field-wiring terminals**

Potential involved, volts	Minimum spacings, inch (mm)		
	Between wiring terminals, through air, or over surface	Between terminals and other uninsulated metal parts not always of the same polarity ^a	
		Over surface	Through air
250 or less	1/4 (6.4)	1/4 (6.4)	1/4 (6.4)

^a Applies to the sum of the spacings involved where an isolated dead part is interposed.

Figure 41.1
Component spacings

Figure 41.1 revised January 26, 1998

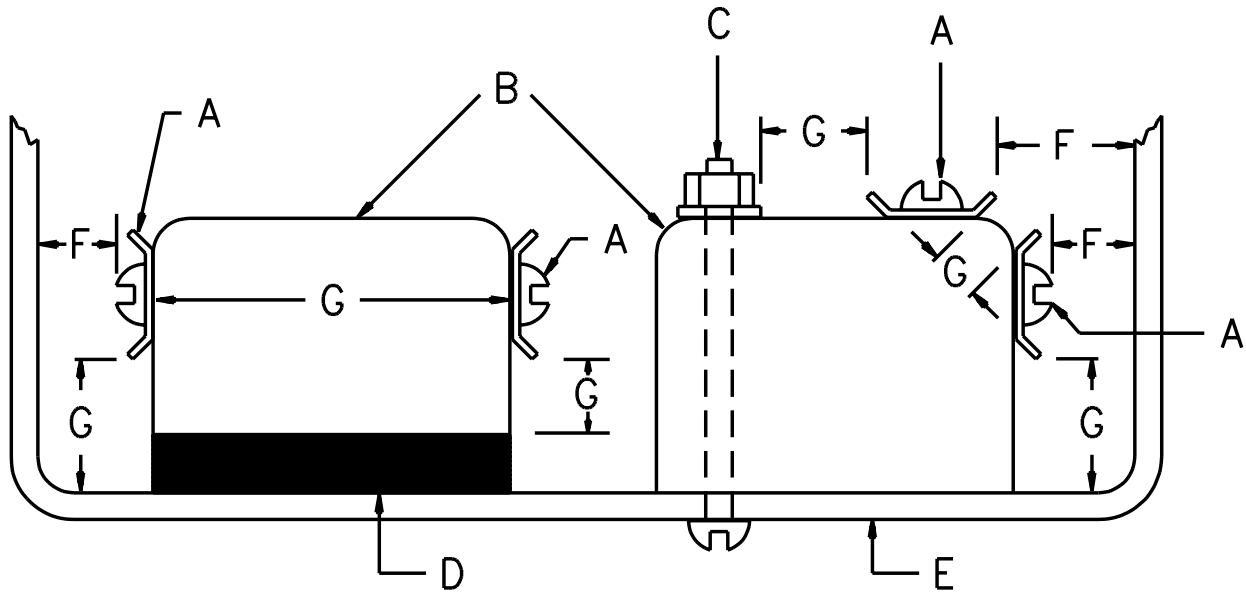

SM100

- A – Uninsulated live parts of a component.
- B – Insulating material of a component.
- C – Mounting screw of a component.
- D – Dead metal part of a component.
- E – Dead metal parts of the product.
- F – Spacings to which the requirements of this standard apply unless specifically noted otherwise.
- G – Spacings to which the requirements of this standard do not apply.

41.2 Spacings, other than at field-wiring terminals, between uninsulated live parts of opposite polarity, and between an uninsulated live part and a dead metal part, shall be not less than the value specified in Table 41.2. When an uninsulated live part is not rigidly fixed in position by means other than friction between surfaces, or when a movable dead metal part is in proximity to an uninsulated live part, the construction shall maintain the minimum required spacing.

Exception: The spacing requirements in Table 41.2 do not apply to the inherent spacings of a component of an appliance, such as a switch. Such spacings are to comply with the requirements for the component in question.

41.3 An uninsulated rotor conductor or a rotor circuit is to be regarded as a dead metal part with respect to the stator circuit, and the applicable minimum spacing shall be provided between uninsulated stator and rotor conductors.

41.4 In the application of 41.2 and 46.1 and Table 41.2 to a blower assembly employing a motor not rated in horsepower, the appropriate table of the National Electrical Code, ANSI/NFPA 70-1996, is to be used to determine the relationships between horsepower and full-load current.

Table 41.2
Minimum spacings at other than field wiring terminals

Potential involved, volts	Minimum spacings, inch (mm)			
	Appliance employing a motor having a diameter 7 inches (178 mm) or less ^a		Appliance employing a motor having a diameter more than 7 inches (178 mm) ^{a,b}	
	Over surface	Through air	Over surface	Through air
0 – 125	3/32 (2.4) ^c	3/32 (2.4) ^c	1/4 (6.4)	1/8 (3.2)
126 – 250	3/32 (2.4)	3/32 (2.4)	1/4 (6.4)	1/4 (6.4)

^a This is the diameter, measured in the plane of the laminations of the circle circumscribing the stator frame, excluding lugs, fins, or boxes used solely for motor mounting, cooling, assembly, or connection.

^b A spacing of not less than 3/32 inch, over surface and through air, between film-coated wire, rigidly supported and held in place on a coil, and a dead metal part is capable of being used.

^c For an appliance only employing motors rated 1/3 horsepower (249 W output) or less, these spacings shall be not less than 1/16 inch (1.6 mm).

41.5 At terminal screws and studs to which connections are made in the field by wire connectors and eyelets, spacings shall be not less than those specified in Table 41.2 with the connectors, eyelets, and other hardware, in such position that minimum spacings are created between parts of opposite polarity and to dead metal.

41.6 A barrier or liner of vulcanized fiber or similar material employed in lieu of required minimum spacings shall be of material capable of being used for the application and shall be not less than 1/32 inch (0.8 mm) thick.

Exception No. 1: The thickness of a barrier or liner used in conjunction with not less than one-half the required spacing through air, shall not be less than 1/64 inch (0.4 mm), when the barrier or liner is of insulating material, resistant to moisture, has mechanical strength when exposed or otherwise subjected to mechanical damage, and located so that it is not subjected to deterioration, such as by the effects of electrical arcs, during intended operation of the blower assembly.

Exception No. 2: Insulating material having a thickness less than that specified shall not be used unless, upon investigation, it is found to meet the intent of the requirement for the particular application.

41.7 In a reversible shaded-pole motor, the spacings between the main windings and the shading coils or between the shading coils and the stator core shall not be less than the values specified in Table 41.2 unless the insulation between the main windings and the shading coils, or between the shading coils and the stator dead metal, is at least 1/64 inch (0.4 mm) thick.

Exception: Insulating material having a thickness less than that specified shall be used when, upon investigation, it is found to meet the intent of the requirement for the particular application.

41.8 Spacings in a motor shall comply with the spacing requirements in the Standard for Electric Motors, UL 1004.

PERFORMANCE

42 Test Voltages

42.1 The product is to be tested at the potentials, maintained at the supply connections, specified in Table 42.1.

Table 42.1
Test voltages

Nameplate voltage rating	Test voltage at 60 hertz ^a	
	Input test	All other tests
110 to 120	115	120
208	208	208
220 to 240	230	240

^a Products rated at frequencies other than 60 hertz are to be tested at their rated voltages and frequencies.

43 Temperature Measurements**43.1 Thermocouple method**

43.1.1 Temperatures of electrical components are to be measured by thermocouples, or by the change-in-resistance method to measure the temperature of motor windings or of coils. The thermocouples are to consist of Nos. 24 – 30 AWG (0.21 – 0.05 mm²) wires. Thermocouple wire is to comply with the requirements for "special thermocouples" as listed in the Table of Limits of Error of Thermocouples in the Standard for Temperature Measurement Thermocouples, ANSI MC96.1-1982.

43.1.2 A thermocouple junction and adjacent thermocouple lead wire are to be securely held in thermal contact with the surface of the material whose temperature is being measured. In most cases, thermal contact results from securely taping or cementing the thermocouple in place, and where a metal surface is involved, brazing or soldering the thermocouple to the metal is required.

43.1.3 When thermocouples are used in the determination of temperatures in connection with the heating of electrical equipment, it is a standard practice to employ thermocouples consisting of No. 30 AWG (0.05 mm²) iron and constantan wires and a potentiometer type indicating instrument. This equipment is to be used whenever referee temperature measurements by means of thermocouples are required.

43.2 Change-in-resistance method

43.2.1 When the temperature of a motor winding or coil is to be determined by the change-in-resistance method, the following formula shall be used:

$$T = \frac{R}{r} (k + t_1) - (k + t_2)$$

in which:

T is the temperature rise in degrees C;

R is the resistance, in ohms, of the coil at the end of the test;

r is the resistance, in ohms, of the coil at the start of the test;

t₁ is the room temperature, in degrees C, at the start of the test;

t₂ is the room temperature, in degrees C, at the end of the test; and

k is 234.5 for copper, 225.0 for electrical conductor grade (EC) aluminum. Values of the constant (k) for other grades must be determined.

43.2.2 When it is required to de-energize the winding before measuring R, the value of R at shutdown is to be determined by taking several resistance measurements at short intervals, beginning as quickly as possible after the instant of shutdown. A curve of the resistance values and the time is to be plotted and extrapolated to give the value of R at shutdown. The motor or coil winding is to be at room temperature at the start of the test.

44 Input Test

44.1 The power input to a blower assembly shall be not more than 105 percent of its marked rating.

44.2 In determining compliance with the requirement in 44.1, the power input is to be measured with the blower assembly of the fireplace connected to a supply circuit of rated voltage in accordance with 42.1.

45 Temperature Test – Electrical Components

45.1 The temperature rises measured on the electrical components and enclosure of a blower assembly during the Radiant Fire Test, Section 12 and Brand Fire Test, Section 13 shall be not greater than those specified for the specific component in Column 1 of Table 10.1. See also Temperature Measurement, Section 10. For the Flash Fire Test, temperatures in Column 2 apply.

45.2 The indicated maximum temperature rises shall not be exceeded during any condition of operation of the fireplace with the power supply to the blower assembly disconnected.

46 Dielectric Voltage Withstand Test

46.1 A complete blower assembly and all electrical components shall withstand for a period of 1 minute, without breakdown, the application of a 60 hertz potential between high-voltage live parts and dead metal parts and between live parts of high- and low-voltage circuits of 1000 volts plus twice rated voltage.

Exception: The test potential for motors rated at not more than 1/2 horsepower (373 watts output) and not more than 250 volts shall be 1000 volts. See 41.4.

46.2 When higher than rated voltage is developed in a motor circuit as a result of the use of capacitors, the rated voltage is to be employed in determining the test potential unless the developed steady-state capacitor voltage, as determined in the Temperature Test – Electrical Components, Section 45, exceeds 500 volts. In that case, the test potential for the parts affected is to be 1000 volts plus twice the developed capacitor voltage.

46.3 A 500 volt-ampere or larger transformer with sinusoidal output that is capable of being varied is to be used for this test. The applied potential is to be increased gradually from zero until the required test value is reached and is to be held at that value for 1 minute.

Exception: The requirement of a 500 volt-ampere or larger transformer is not required when the testing equipment used maintains the specified high potential voltage at the product during the test.

47 Stalled Motor Test

47.1 The motor protective means of an impedance protected blower motor, under stalled rotor condition and during the Fire Tests, see Sections 12 – 14, shall prevent the motor winding from attaining a temperature rise of more than 225°F (125°C) for Class A insulation systems and 270°F (150°C) for Class B insulation systems when tested as described in 47.2 and 47.3.

47.2 The rotor is to be mechanically locked while the motor is energized at its maximum operating voltage.

47.3 Motor temperatures are to be measured by thermocouples placed on the case of a totally enclosed motor or on the stator windings of an open motor.

48 Strain Relief Test

48.1 Each lead employed for field connections shall withstand for 1 minute a pull of 10 pounds-force (44.5 N) without any evidence of damage to the lead or of transmittal of the stress to internal connections.

48A Push-Back Relief Test

48A.1 To determine compliance with 33.2.10, a product shall be tested in accordance with 48A.2 without occurrence of any of the conditions specified in 33.2.11 (a) – (e).

Revised 48A.1 effective May 17, 1999

48A.2 The supply cord or lead is to be held 1 inch (25.4 mm) from the point where the cord or lead emerges from the product and is then to be pushed back into the product. When a removable bushing which extends further than 1 inch is present, it is to be removed prior to the test. When the bushing is an integral part of the cord, the test is to be carried out by holding the bushing. The cord or lead is to be

pushed back into the product in 1-inch (25.4-mm) increments until the cord buckles or the force to push the cord into the product exceed 6 pounds-force (26.7 N). The supply cord or lead within the product is to be manipulated to determine compliance with 33.2.10.

Revised 48A.2 effective May 17, 1999

49 Short-Circuit Test

49.1 Motor overload protective devices, required bonding conductors, and conductors of motor or control circuits shall withstand short circuiting when protected by a fuse of the size required by the blower assembly.

49.2 The device is to be connected in a circuit having a capacity based on the rated current and voltage of the blower assembly. See Table 49.1. The voltage source for the test circuit is to be an alternating-current supply and the circuit capacity is to be measured without the device in the circuit.

Table 49.1
Short-circuit test currents

Full-load amperes			Circuit capacity, amperes
115 V	Single phase		
	208 V	230 – 240 V	
9.8 or less	5.4 or less	4.9 or less	200
9.9 – 16.0	5.5 – 8.8	5.0 – 8.0	1000
16.1 – 34.0	8.9 – 18.6	8.1 – 17.0	2000
34.1 – 80.0	18.7 – 44.0	17.1 – 40.0	3500
Over 80.0	Over 44.0	Over 40.0	5000

49.3 A nonrenewable cartridge fuse is to be connected in series with the device. A new fuse and device or conductor are to be used for each test.

50 Knockout Test

50.1 A knockout shall remain in place when a force of 10 pounds (44.5 N) is applied at right angles to the knockout by a 1/4 inch (6.4 mm) diameter mandrel with a flat end. The force is to be applied at the point that results in movement of the knockout.

MANUFACTURING AND PRODUCTION TESTS

51 Production Line Dielectric Voltage-Withstand Test

51.1 The manufacturer shall conduct a dielectric voltage-withstand test on each blower assembly. A 60 hertz potential as indicated below is to be applied between high-voltage live parts and dead metal parts for a period of 1 minute.

Exception: The time of application of the potential is reduced to 1 second when the value of the test potential is 120 percent of 1000 volts for units rated 250 volts or less.

51.2 For blower assemblies employing low-voltage circuits, the test is to be conducted with the low-voltage circuit connected to the cabinet, chassis, or other dead metal part so that the potential that is applied between the high-voltage live parts and dead metal parts shall simultaneously be applied between high-voltage live parts and low-voltage circuits.

51.3 When the blower assembly employs components such as a solid state control which is capable of being damaged by the dielectric potential, the test is to be conducted before the components are electrically connected. However, a random sampling of each day's production is to be tested with the components electrically connected to demonstrate compliance with the requirements in 51.1. For the test, the blower assembly is to be in a heated or unheated condition.

51.4 A 500 volt-ampere or larger transformer, with sinusoidal output voltage that is capable of being varied, is to be used to determine compliance with the requirement in 51.1.

Exception: A 500 volt-ampere or larger transformer is not required when the high potential testing equipment maintains the specified high potential voltage at the equipment during the duration of the test.

51.5 The test equipment used for the test in 51.1 is to include a visible indication of application of the test potential and an audible or visible indication of breakdown. In the event of breakdown, manual reset of an external switch is to be required, or an automatic reject of the unit under test is to result. Other arrangements are identified and accepted when found to achieve the results contemplated.

MARKING

52 General

52.1 Markings on a fire chamber shall be permanent and, unless otherwise required to be placed at a specific location, shall be grouped together and located where they are visible and legible after the fireplace is installed.

Exception: Locations within a compartment used to operate an appliance and provided with doors or panels intended to be opened or removed without requiring the use of a tool are determined visible.

52.2 A marking required to be permanent shall be molded; die-stamped; paint-stenciled, stamped, or etched in metal that is permanently secured; or indelibly stamped on a pressure-sensitive label. Usage, handling, and storage of the product are to be evaluated in determining the permanence of the marking. See Marking Permanency Test, Section 53.

52.3 Each fire chamber shall be marked with the following:

- a) The manufacturer's or private labeler's name or identifying symbol.
- b) A distinctive type or model designation.
- c) The electrical rating, when applicable, in volts (volts, alternating current), amperes, or watts, and frequency in hertz. This information shall be on the blower assembly when field installed.
- d) Date of manufacture (at least by quarter and year) which is in an established or otherwise traceable code.

52.4 A fire chamber shall be marked: "See (manufacturer's or private labeler's name) installation and operating instructions for this model."

52.5 A fire chamber for use in manufactured homes shall be marked: "Fireplace, Also For Use In Manufactured Homes With Solid ^(a) Fuel Only."

^(a)Wood or coal (or both, as appropriate)

Revised 52.5 effective January 13, 2000

52.6 A fire chamber shall also be marked at the back and sides in minimum 1 inch (25.4 mm) high red letters on a contrasting background with the word "WARNING" and the following or equivalent statement: "Risk of fire. Minimum ___^(a)___ air space clearance to insulation and building materials must be maintained." This marking shall appear at each location on the fire chamber where clearance is required.

Exception: A fire chamber intended for installation directly upon and adjacent to combustible building construction is not required to be marked with the warning marking regarding clearances.

^(a)Manufacturer's specified minimum clearance

No Text on This Page

52.7 A fire chamber that incorporates an open or ventilated chimney connector or collar shall be marked on the top of the fire chamber adjacent to the chimney connector/collar in minimum 3/16 inch (4.8 mm) high red letters on a contrasting background with the word "WARNING" and the following or equivalent statement: "Risk of fire. Do not block holes or insulate top of fireplace."

52.8 A fireplace not tested with glass doors shall be marked with the statement "WARNING" and the following or equivalent statement: "This fireplace has not been tested for use with glass doors. To reduce the risk of fire or injury, do not install glass doors."

52.9 A fireplace having provision for doors shall be marked with the following or equivalent statement: "When doors are used, operate fireplace with doors fully open or fully closed only."

Exception: This marking is not required when gas and flame are determined not to be drawn out of the fireplace when the doors are in any possible opening position during the performance tests in this standard.

52.10 A fireplace provided with an adjustable flue-gas outlet damper shall be marked at or near the fuel-feeding door where visible before opening doors: "Open damper before opening doors."

52.11 A fireplace having provision for connection of a decorative gas burning appliance shall be marked with the following or equivalent statement: "When burning gas in the fireplace, adjust damper to the fully open position."

52.12 A fireplace shall be marked with the following or equivalent statement: "Use ^(a) fuel only."

^(a)Solid wood, processed solid fuel firelogs or other specified type of fuel.

52.12 revised August 25, 1997

52.13 A fireplace shall be marked with the following or equivalent statement: "Do not use a fireplace insert or other products not specified for use with this product." When the fireplace has been investigated and found to be capable of being used with a specified fireplace insert, or other specified product, the statement shall be modified as appropriate.

52.13.1 A fireplace that has not been tested for use with an Unvented Gas Log Set shall be marked with the word, "WARNING", and the following or equivalent statement: "THIS FIREPLACE HAS NOT BEEN TESTED WITH AN UNVENTED GAS LOG SET. TO REDUCE RISK OF FIRE OR INJURY, DO NOT INSTALL AN UNVENTED GAS LOG SET INTO FIREPLACE."

Added 52.13.1 effective May 17, 1999

52.13.2 A fireplace that has been found to comply with the Optional Unvented Decorative Log Temperature Test, Section 14A, shall be marked with the following or equivalent statement: "ONLY UNVENTED GAS LOG SETS WHICH HAVE BEEN FOUND TO COMPLY WITH THE STANDARD FOR UNVENTED ROOM HEATERS, ANSI/IAS/AGA Z21.11.2, ARE TO BE INSTALLED IN THIS FIREPLACE."

Added 52.13.2 effective May 17, 1999

52.13.3 A fireplace that has been found to comply with the Optional Unvented Decorative Log Temperature Test, Section 14A, shall be marked with the word, "WARNING", and the following or equivalent statement: "DO NOT OPERATE AN UNVENTED GAS LOG SET IN THIS FIREPLACE WITH THE CHIMNEY REMOVED."

Added 52.13.3 effective May 17, 1999

52.14 When a manufacturer produces fireplaces or blower assemblies at more than one factory, each individual assembly shall have a distinctive marking to identify it as the product of a particular factory.

52.15 Each individual part, such as a chimney section, firestop, radiation shield and roof housing shall be marked with the following:

- a) The manufacturer's or private labeler's name or identifying symbol.
- b) Distinctive type or model designation.

52.16 The exterior surface of each chimney section assembly shall be permanently marked with the following or equivalent statement: "Minimum clearance ^(a) air space to insulation and building materials." This and other required marking information shall appear at least once on each chimney section and shall be repeated at 5 foot (1.5 m) intervals on sections longer than 5 feet.

^(a)Manufacturer's specified minimum clearance.

52.17 Each chimney pipe section of a fireplace assembly complying with the requirements in 11.4.1 – 11.4.5, Temperature Test – 2100°F Flue Gases, shall be permanently marked "Type HT."

No Text on This Page

52.18 A blower assembly intended for field installation in or on a fireplace shall be marked with:

- a) The name or identifying symbol of the manufacturer or vendor;
- b) The catalog number or equivalent designation;
- c) The electrical rating, when applicable, in volts (volts, alternating current), amperes, or watts, and frequency in hertz; and
- d) Designation of the product with which it is intended to be used.

The associated fireplace shall be marked to indicate the catalog number or equivalent designation of such an accessory and the name of the manufacturer or vendor of that accessory.

52.19 With reference to the requirements in 52.18, instructions for installing the blower assembly shall be provided on or with the blower assembly and shall indicate that the blower assembly is intended for use only with the fireplace marked to indicate such use, and that the blower assembly must be disconnected from the source of electrical supply (as appropriate) before attempting the installation.

52.20 When the construction of the blower assembly necessitates disassembly for the purpose of cleaning or similar servicing by the user and when such disassembly involves the exposure of persons to possible contact with enclosed or protected live parts, moving parts that result in injury to persons or hot parts, the fireplace accessory shall be plainly marked with the appropriate statement(s) indicated below:

- a) "CAUTION" and the following or equivalent wording, "Moving Parts May Cause Injury. Do Not Operate Unit With ^(a) Removed."
- b) "CAUTION" and the following or equivalent wording, "Hot Parts. Do Not Operate Unit With ^(a) Removed."
- c) "DANGER" and the following or equivalent wording, "Risk of Electric Shock. Disconnect Power Before Servicing Unit." When applying this requirement it is to be assumed that parts, such as fronts and grilles shall be periodically removed.

^(a)Specify appropriate part

52.21 The warning marking specified in 52.20 shall be located so as to be visible before or immediately upon removal of a cover or panel that encloses or protects the moving part, hot part, or live part. The marking shall not be on the back of a removable cover or panel.

52.22 With respect to the requirements in 52.21, when the marking is located on a removable panel or cover, replacement of the panel or cover, or its means of attachment, shall not obscure the warning.

52.23 Unless correct field wiring connections are obvious, a wiring diagram shall be attached to each permanently-connected blower assembly to show the intended method of making field wiring connections. A paper sticker glued, or shellacked, or both, to an accessible cover is capable of being used.

52.24 Terminals for field wiring shall be marked: "USE COPPER CONDUCTORS ONLY," "FOR USE WITH ALUMINUM OR COPPER CONDUCTORS," or with an equivalent statement, as appropriate. This marking shall be independent of any marking on terminal connectors.

52.25 When a blower assembly is provided as a field installed accessory, it shall be marked with its date of manufacture (at least by quarter and year) which is in an established or otherwise traceable code.

MARKING PERMANENCY

53 Marking Permanency Tests

53.1 General

53.1.1 After being subjected to the conditions described in 53.2.1 – 53.4.1, a marking is identified to be permanent when immediately following removal from each test medium:

- a) Each sample demonstrates adhesion and the edges are not curled.
- b) The marking resists defacement or removal as demonstrated by scraping with a 2 pound-force (9 N) across the test panel with a flat metal blade 5/64 inch (2.0 mm) thick, held at right angles to the test panel.
- c) The printing is legible and is not defaced by rubbing back and forth ten times with thumb or finger pressure (total of 20 rubs).

53.2 Air oven-aging test

53.2.1 Three samples of the marking applied to test surfaces as in the intended application are to be placed in an air oven maintained at the temperature developed during the Radiant Fire Test, Section 12 or Brand Fire Test, Section 13, whichever is higher, for 24 hours and then cooled in a controlled atmosphere maintained at $23 \pm 2^{\circ}\text{C}$ ($73.4 \pm 3.6^{\circ}\text{F}$) and 50 percent relative humidity for 72 hours.

53.3 Humidity test

53.3.1 Three samples of the marking applied to test surfaces as in the intended application are to be placed in a controlled atmosphere maintained at $23 \pm 2^{\circ}\text{C}$ ($73.4 \pm 3.6^{\circ}\text{F}$) with a 50 ± 5 percent relative humidity for 24 hours. The samples then are to be suspended in a humidity cabinet for 72 hours at $32 \pm 2^{\circ}\text{C}$ ($90 \pm 4^{\circ}\text{F}$) and 85 ± 5 percent relative humidity.

53.4 Unusual-condition exposure test

53.4.1 When the marking is exposed to unusual conditions in service, such as oil, grease or cleaning solutions three samples of the marking applied to test surfaces as in the intended application are to be placed in a controlled atmosphere maintained at $23 \pm 2^{\circ}\text{C}$ ($73.4 \pm 3.6^{\circ}\text{F}$) with a 50 ± 5 percent relative humidity for 24 hours. The samples then are to be immersed for 48 hours in a solution representative of service use maintained at the temperature the solution attains in service, and in no case less than 23°C (73°F).

INSTALLATION INSTRUCTIONS

54 Installation and Operating Instructions

54.1 General

54.1.1 The installation and operating instructions shall either be combined in a single manual or be separate manuals, and shall be packed with the fire chamber of the fireplace.

54.1.2 When the installation of a fireplace part, such as a blower, controller, air duct system, or glass door assembly is not prohibited, detailed instructions for the installation shall be provided with the assembly.

54.1.3 The instructions shall make reference to the manufacturer's or private labeler's catalog designations, or equivalent, for the fireplace and related parts, and shall include the manufacturer's or private labeler's name and address. All required WARNING and CAUTION statements shall be in bold faced, upper case letters.

54.1.3 revised January 13, 1999

54.2 Installation instructions

54.2.1 The installation instructions are to be used as a reference during the examination and tests of a factory-built fireplace. The instructions are not required to be in final printed form for the investigation.

54.2.2 Installation instructions shall be illustrated and include directions and information required to complete the intended installation of the fireplace, chimney, and related parts, including reference to the existence of parts tested for use with the fireplace.

54.2.3 The instructions shall include particular details concerning:

a) The parts required and the step-by-step process for installing the fireplace and its chimney, including methods of their support, and the securing of roof assemblies. Nails, lag bolts, or other fastening means required to secure parts are to be specified. Component part descriptions shall be illustrated and described in written form, including accurate identification of major parts such as chimney sections, firestop, and the roof cap.

b) The methods and precautions required to enclose the fireplace and its parts with walls, partitions, and other structures, including the framing of fireplace openings. Any required clearances (air spaces) shall be specified and illustrated.

c) The materials or parts to be employed for hearth extensions and their elevation relative to the fire chamber. When a factory-built hearth extension is used during the performance tests in these requirements, its use shall be specified in the installation instructions.

cc) Installation of an unvented gas log set into a fireplace. When a fireplace has been tested with an unvented log set which has been found to comply with the Standard for Unvented Room Heaters, ANSI/IAS/AGA Z21.11.2, and is installed into the fireplace in accordance with the Unvented Decorative Log Temperature Test, Section 14A, the instructions shall specify that the fireplace has been found to comply with the Standard for Factory-Built Fireplaces, UL 127, when installed with unvented gas log sets. When the fireplace has not been tested employing an unvented gas log set, the instructions shall include the word "WARNING" and the following or equivalent statement: "THIS FIREPLACE HAS NOT BEEN TESTED WITH AN UNVENTED GAS LOG SET. TO REDUCE RISK OF FIRE OR INJURY, DO NOT INSTALL AN UNVENTED GAS LOG SET INTO THIS FIREPLACE."

d) Statements concerning the use of either required sealing strips of noncombustible materials between the fireplace hearth and factory-built hearth extension or the use of a sand-cement grout between the hearth and an on-site-constructed hearth extension.

e) An illustration of the vertical relationship between the fireplace, sealing strips, and the hearth extension and a warning statement to the effect that the hearth extension is to be installed only as illustrated.

- f) The minimum hearth extension areas to be covered with relation to the fireplace. when the area of the fireplace opening is 6 square feet (0.6 m²) or larger, the hearth extension floor area shall be specified to extend at least 20 inches (508 mm) in front of, and at least 12 inches (305 mm) beyond each side of, the fireplace opening. When the area of the fireplace opening is less than 6 square feet, the corresponding minimum hearth extension floor area shall be specified to extend 16 and 8 inches (406 and 203 mm), respectively, in front of and beyond each side of the opening.
- g) The framing of openings in ceilings and floors to provide firestopping in joist areas, and the installation of firestop-spacer assemblies.
- h) The methods and parts to be employed for maintaining ventilation and air circulation.
- i) The methods and parts to be employed that are intended to prevent contact with building insulation. When the fireplace assembly is required to be marked with air space clearances (see 52.6), the instructions shall include the word "WARNING" and the following or equivalent statement: "DO NOT PACK REQUIRED AIR SPACES WITH INSULATION OR OTHER MATERIALS."
- j) The use of rain caps or roof housings.
- k) The methods and parts to be employed for roof flashing.
- l) The termination of the chimney above a roof and its proximity to adjacent walls or buildings.
- m) Any limitations with respect to installation and use of the fireplace, such as the minimum or maximum height of the combination of fire chamber and chimney, the joining of two or more parts to constitute the intended assembly, and the required installation clearances.
- n) The framing of openings in roofs to provide for support and attachment of roof assemblies.
- o) The methods and parts to be employed to connect a warm air duct system to the exterior of the fire chamber of a circulating warm air type fireplace. Any limitations with respect to installation and use of a warm air duct system, such as the minimum height of the air outlet above the floor, and details for framing the air duct where it penetrates adjacent walls.
- p) The methods and parts to be employed to connect a combustion air inlet system to the exterior of a fire chamber, and any limitations with respect to installation and use of a combustion air inlet system.
- q) Detailed instructions for provisions to be made for blowers and controllers investigated for use with the fireplace.
- r) Installation of doors when doors are provided. When the fireplace has been tested with doors, the instructions shall include the manufacturer's specific part numbers for doors that are used. When the fireplace has not been tested with doors, the instructions shall include the word "WARNING" and the following or equivalent statement: "THIS FIREPLACE HAS NOT BEEN TESTED FOR USE WITH DOORS. TO REDUCE THE RISK OF FIRE OR INJURY, DO NOT INSTALL DOORS."
- s) For a fireplace having provision for installation of a gas pipe, a statement that the provision is intended only for connection to a vented decorative gas appliance:

- 1) Incorporating an automatic shutoff device; and
- 2) Complying with the Standard for Decorative Gas Appliances for Installation in Vented Fireplaces, ANSI Z21.60 (1991) or American Gas Association draft requirements for Gas-Fired Log Lighters for Wood Burning Fireplaces, Draft No. 4 dated August, 1993.

A statement shall also be included that the decorative gas appliance shall be installed in accordance with the National Fuel Gas Code, ANSI Z223.1. The instructions shall include the word "CAUTION" and the following or equivalent statement: "WHEN USING THE DECORATIVE APPLIANCE, THE FIREPLACE DAMPER MUST BE SET IN THE FULLY OPEN POSITION."

- t) A statement to the effect that combustion air inlet ducts shall not terminate in attic spaces.
- u) For fireplaces for use in manufactured homes, the statements: "WARNING" and the following or equivalent: "DO NOT INSTALL IN SLEEPING ROOM;" and "CAUTION" and the following or equivalent: "THE STRUCTURAL INTEGRITY OF THE MANUFACTURED HOME FLOOR, WALL, AND CEILING/ROOF MUST BE MAINTAINED."
- v) The k, C, or R factor that correlates with the hearth extension material used during the test when the fireplace is not provided with a hearth extension. The units of measure for the k, C, and R factors shall use the same applicable units. Directions and examples on how to use alternate materials and how to calculate equivalent thickness shall be shown.
- w) The manufacturer's specifications including the mantel depth (that is, maximum distance from front edge of the mantel to the wall), width, material (noncombustible or combustible, as appropriate), and distance above fireplace opening when the fireplace is intended for use with a mantel.
- x) Installation of a combustible chase enclosure for chimney sections installed above the roof, when the fireplace has been tested with a chase above the roof. The instructions shall include the manufacturer's specifications including clearance to the enclosure, minimum distance from the top of the enclosure to the top of the chimney, and method of closing the chase top. When the fireplace has not been tested with a chase enclosure above the roof, the instructions shall include the word "WARNING" and the following or the equivalent statement, "THIS FIREPLACE HAS NOT BEEN TESTED FOR USE WITH A CHASE ABOVE THE ROOF. TO REDUCE THE RISK OF FIRE, DO NOT INSTALL A CHASE ABOVE THE ROOF."
- y) Installation of any parts that contain openings that provide for air flow between air in the chimney chase and air located between the chimney walls.
- z) Installation and maintenance of a flashing/storm collar assembly. For a chimney assembly that incorporates a ventilated flashing, the instructions shall include specific details, in written and diagrammatic form:
 - 1) Illustrating the openings in their intended location and orientation as installed; and
 - 2) Specifying precautions to be taken such as instructing the installer to not caulk or seal the ventilating openings.

aa) An illustration and statement, for fireplaces for use in manufactured homes, that the ceiling/roof thimble assembly shall extend completely through the ceiling/roof cavity of the manufactured home to the outermost plane of the roof.

Revised 54.2.3 effective January 13, 2000

54.3 Operating instructions

54.3.1 The operating instructions required to be provided with each fireplace assembly are to be used as a reference during the examination and tests of a factory-built fireplace. The instructions are not required to be in final printed form for the investigation.

No Text on This Page

54.3.2 The operating instructions shall include particular details concerning:

a) Operation with doors, when doors are provided with the fireplace. When the fireplace has been tested with doors, the instructions shall include the manufacturer's specific part numbers for doors that are used. When the fireplace has not been tested with doors, the instructions shall include the word "WARNING" and the following or equivalent statement: "THIS FIREPLACE HAS NOT BEEN TESTED FOR USE WITH DOORS. TO REDUCE THE RISK OF FIRE OR INJURY, DO NOT INSTALL DOORS."

b) Operation with doors, to include a diagram and the word "WARNING" and the following or equivalent statement: "FIREPLACES EQUIPPED WITH DOORS SHOULD BE OPERATED ONLY WITH DOORS FULLY OPEN OR DOORS FULLY CLOSED. IF DOORS ARE LEFT PARTLY OPEN, GAS AND FLAME MAY BE DRAWN OUT OF THE FIREPLACE OPENING, CREATING RISKS OF BOTH FIRE AND SMOKE."

Exception: This warning shall be included unless gas and flame are determined not to be drawn out of the fireplace when the doors are in any possible opening position during the performance tests in this standard.

c) Inspection, maintenance, and cleaning of the chimney including method of access through the top of the chimney (for example, method of removing chimney cap).

d) Reference to the formation and removal of creosote buildup in the chimney as follows:

"Creosote – Formation and Need for Removal

When wood is burned slowly, it produces tar and other organic vapors, which combine with expelled moisture to form creosote. The creosote vapors condense in the relatively cool chimney flue of a slow-burning fire. As a result, creosote residue accumulates on the flue lining. When ignited this creosote makes an extremely hot fire.

The chimney shall be inspected at least twice a year during the heating season to determine when a creosote buildup has occurred.

When creosote has accumulated it shall be removed to reduce the risk of a chimney fire."

e) Specifications on building the fire, maintaining the fire, and warnings against overfiring.

f) Caution against the storage or use of flammable liquids, as follows:

"Never use gasoline, gasoline-type lantern fuel, kerosene, charcoal lighter fluid, or similar liquids to start or 'freshen up' a fire in this fireplace. Keep all such liquids well away from the fireplace while it is in use."

g) Clearances from the front of the fireplace to combustible materials.

h) Disposal of ashes, including the following statement:

"Disposal of Ashes

Ashes should be placed in a metal container with a tight-fitting lid. The closed container of ashes should be placed on a noncombustible floor or on the ground, well away from all combustible materials, pending final disposal. If the ashes are disposed of by burial in soil or otherwise locally dispersed, they should be retained in the closed container until all cinders have thoroughly cooled."

i) Reference to the use or nonuse of grates, andirons, or other methods of supporting the fuel.

j) Operation and use of manual damper controls.

k) Operation and use of electrical assemblies.

l) The use of fuels by including the following or equivalent statement: "Use ^(a) fuel only."

m) The use of fireplace inserts and other nonspecified products by including the following or equivalent statement: "Do not use a fireplace insert or other products not specified for use with this fireplace." When the fireplace has been investigated and found to be capable of being used with a specified fireplace insert, or other specified product, the statement shall be modified as appropriate.

n) A warning when processed solid fuel firelogs are used: "Do not poke or stir the logs while they are burning. Use only firelogs that have been evaluated for the application in fireplace and refer to firelog warnings and caution markings on packaging prior to use."

^(a)Solid wood, processed solid fuel firelogs or other specified type of fuel.

54.3.2 revised August 25, 1997

No Text on This Page

Standards for Components

Standards under which components of the products covered by this standard are evaluated include the following:

Title of Standard – UL Standard Designation

Controls, Limit – UL 353
Cord Sets and Power-Supply Cords – UL 817
Motor-Operated Appliances, Electric – UL 73
Motors, Electric – UL 1004
Motors, Overheating Protection for – UL 2111
Plastic Materials for Parts in Devices and Appliances, Tests for Flammability of – UL 94
Polymeric Materials – Fabricated Parts – UL 746D
Polymeric Materials – Long Term Property Evaluations – UL 746B
Polymeric Materials – Short Term Property Evaluations – UL 746A
Polymeric Materials – Use in Electrical Equipment Evaluations – UL 746C
Switches, Snap, General-Use – UL 20
Switches, Special-Use – UL 1054
Temperature-Indicating and -Regulating Equipment – UL 873
Transformers, Specialty – UL 506
Wire Connectors and Soldering Lugs for Use With Copper Conductors – UL 486A

No Text on This Page

**Superseded requirements for
the Standard for
Factory-Built Fireplaces
UL 127, Seventh Edition**

The requirements shown are the current requirements that have been superseded by requirements in revisions issued for this Standard. To retain the current requirements, do not discard the following requirements until the future effective dates are reached.

26.1.1 Fireplace for use in mobile homes are intended for installation in accordance with the requirements of the Department of Housing and Urban Development (HUD) "Mobile Home Construction and Safety Standards."

26.1.2 A fireplace for use in mobile homes shall comply with all requirements elsewhere in this standard unless otherwise specified in this section.

26.1.3 Means shall be provided for securing the fireplace to the floor of the mobile home.

26.1.5 With its chimney installed, the configuration of a fireplace shall not void the required firestopping between spaces of a mobile home when the fireplace, chimney, and the combustion air inlet are installed in accordance with the manufacturer's instructions.

26.2.1 The chimney shall extend at least 3 feet (0.9 m) above the part of the roof through which it passes. The top of the chimney is to be at least 2 feet (0.6 m) above the highest required elevation of any part of the mobile home located within 10 feet (3 m) of the chimney.

26.2.3 When the chimney exits the mobile home at a location other than through the roof, and exits at a point 7 feet (2.1 m) or less above the ground level on which the mobile home is positioned, a guard or method of enclosing the chimney shall be provided at the point of exit so that the chimney is guarded or enclosed up to a height of 7 feet.

26.4.1 The cross sectional area of the combustion air inlet shall be not less than 50 percent of the cross sectional flue area or 25 square inches (161 cm²), whichever is smaller. This inlet shall conduct the combustion air directly from outside the mobile home to the connection to the draft inlet of the fire chamber assembly.

26.6.1 The chimney of the fireplace is to pass through the ceiling/roof or wall of the mobile home test structure at zero clearance. This is accomplished by a thimble or through the inherent construction of the chimney or fireplace. The construction shall not void the firestopping required for a concealed space when installed in accordance with the manufacturer's installation instructions.

26.6.3 A fireplace intended for use in mobile homes shall comply with the requirements in Sections 11 – 25.

Figure 26.1
Mobile home test enclosure

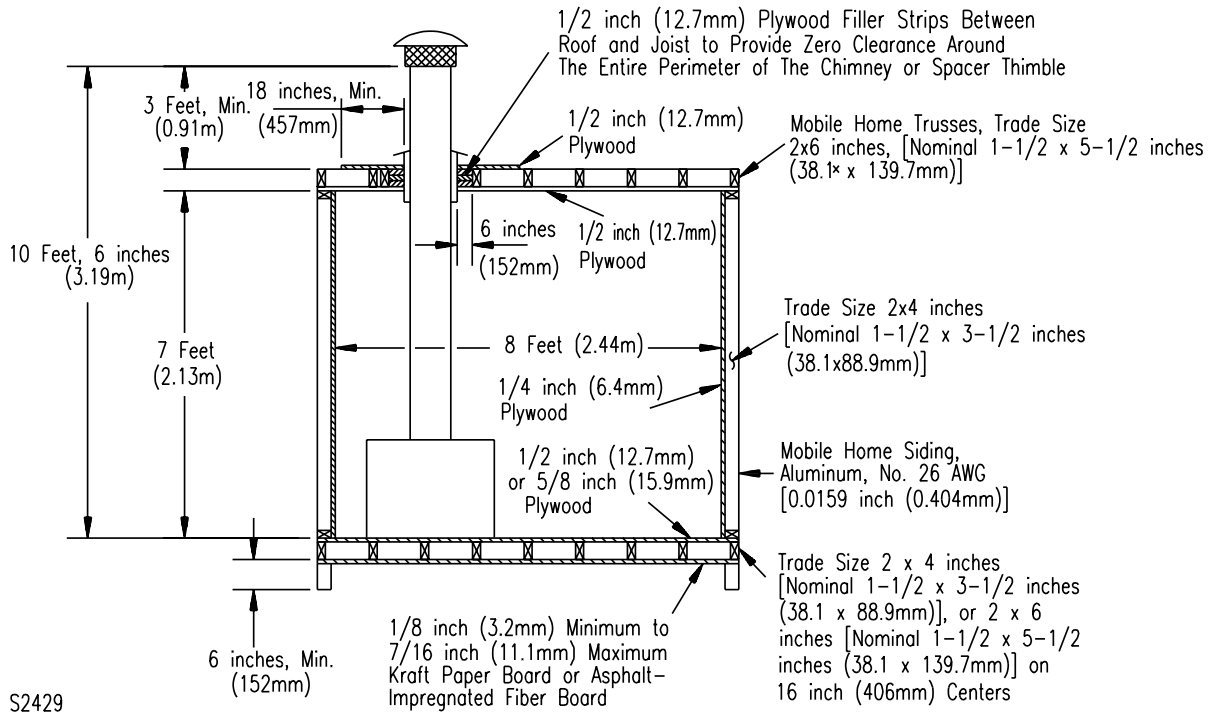

52.5 A fire chamber for use in mobile homes shall be marked: "Fireplace, Also For Use In Mobile Homes With Solid (a) Fuel Only."

(a) Wood or coal (or both, as appropriate)

54.2.3 The instructions shall include particular details concerning:

- a) The parts required and the step-by-step process for installing the fireplace and its chimney, including methods of their support, and the securing of roof assemblies. Nails, lag bolts, or other fastening means required to secure parts are to be specified. Component part descriptions shall be illustrated and described in written form, including accurate identification of major parts such as chimney sections, firestop, and the roof cap.
- b) The methods and precautions required to enclose the fireplace and its parts with walls, partitions, and other structures, including the framing of fireplace openings. Any required clearances (air spaces) shall be specified and illustrated.
- c) The materials or parts to be employed for hearth extensions and their elevation relative to the fire chamber. When a factory-built hearth extension is used during the performance tests in these requirements, its use shall be specified in the installation instructions.
- d) Statements concerning the use of either required sealing strips of noncombustible materials between the fireplace hearth and factory-built hearth extension or the use of a sand-cement grout between the hearth and an on-site-constructed hearth extension.

- e) An illustration of the vertical relationship between the fireplace, sealing strips, and the hearth extension and a warning statement to the effect that the hearth extension is to be installed only as illustrated.
- f) The minimum hearth extension areas to be covered with relation to the fireplace. When the area of the fireplace opening is 6 square feet (0.6 m²) or larger, the hearth extension floor area shall be specified to extend at least 20 inches (508 mm) in front of, and at least 12 inches (305 mm) beyond each side of, the fireplace opening. When the area of the fireplace opening is less than 6 square feet, the corresponding minimum hearth extension floor area shall be specified to extend 16 and 8 inches (406 and 203 mm), respectively, in front of and beyond each side of the opening.
- g) The framing of openings in ceilings and floors to provide firestopping in joist areas, and the installation of firestop-spacer assemblies.
- h) The methods and parts to be employed for maintaining ventilation and air circulation.
- i) The methods and parts to be employed that are intended to prevent contact with building insulation. When the fireplace assembly is required to be marked with air space clearances (see 52.6), the instructions shall include the word "WARNING" and the following or equivalent statement: "DO NOT PACK REQUIRED AIR SPACES WITH INSULATION OR OTHER MATERIALS."
- j) The use of rain caps or roof housings.
- k) The methods and parts to be employed for roof flashing.
- l) The termination of the chimney above a roof and its proximity to adjacent walls or buildings.
- m) Any limitations with respect to installation and use of the fireplace, such as the minimum or maximum height of the combination of fire chamber and chimney, the joining of two or more parts to constitute the intended assembly, and the required installation clearances.
- n) The framing of openings in roofs to provide for support and attachment of roof assemblies.
- o) The methods and parts to be employed to connect a warm air duct system to the exterior of the fire chamber of a circulating warm air type fireplace. Any limitations with respect to installation and use of a warm air duct system, such as the minimum height of the air outlet above the floor, and details for framing the air duct where it penetrates adjacent walls.
- p) The methods and parts to be employed to connect a combustion air inlet system to the exterior of a fire chamber, and any limitations with respect to installation and use of a combustion air inlet system.
- q) Detailed instructions for provisions to be made for blowers and controllers investigated for use with the fireplace.
- r) Installation of doors when doors are provided. When the fireplace has been tested with doors, the instructions shall include the manufacturer's specific part numbers for doors that are used. When the fireplace has not been tested with doors, the instructions shall include the word "WARNING" and the following or equivalent statement: "THIS FIREPLACE HAS NOT BEEN TESTED FOR USE WITH DOORS. TO REDUCE THE RISK OF FIRE OR INJURY, DO NOT INSTALL DOORS."

s) For a fireplace having provision for installation of a gas pipe, a statement that the provision is intended only for connection to a vented decorative gas appliance:

- 1) Incorporating an automatic shutoff device; and
- 2) Complying with the Standard for Decorative Gas Appliances for Installation in Vented Fireplaces, ANSI Z21.60 (1991) or American Gas Association draft requirements for Gas-Fired Log Lighters for Wood Burning Fireplaces, Draft No. 4 dated August, 1993.

A statement shall also be included that the decorative gas appliance shall be installed in accordance with the National Fuel Gas Code, ANSI Z223.1,. The instructions shall include the word "CAUTION" and the following or equivalent statement: "WHEN USING THE DECORATIVE APPLIANCE, THE FIREPLACE DAMPER MUST BE SET IN THE FULLY OPEN POSITION."

t) A statement to the effect that combustion air inlet ducts shall not terminate in attic spaces.

- u) For fireplaces for use in mobile homes, the statements: "WARNING" and the following or equivalent: "DO NOT INSTALL IN SLEEPING ROOM;" and "CAUTION" and the following or equivalent: "THE STRUCTURAL INTEGRITY OF THE MOBILE HOME FLOOR, WALL, AND CEILING/ROOF MUST BE MAINTAINED."
- v) The k, C, or R factor that correlates with the hearth extension material used during the test when the fireplace is not provided with a hearth extension. The units of measure for the k, C, and R factors shall use the same applicable units. Directions and examples on how to use alternate materials and how to calculate equivalent thickness shall be shown.
- w) The manufacturer's specifications including the mantel depth (that is, maximum distance from front edge of the mantel to the wall), width, material (noncombustible or combustible, as appropriate), and distance above fireplace opening when the fireplace is intended for use with a mantel.
- x) Installation of a combustible chase enclosure for chimney sections installed above the roof, when the fireplace has been tested with a chase above the roof. The instructions shall include the manufacturer's specifications including clearance to the enclosure, minimum distance from the top of the enclosure to the top of the chimney, and method of closing the chase top. When the fireplace has not been tested with a chase enclosure above the roof, the instructions shall include the word "WARNING" and the following or the equivalent statement, "THIS FIREPLACE HAS NOT BEEN TESTED FOR USE WITH A CHASE ABOVE THE ROOF. TO REDUCE THE RISK OF FIRE, DO NOT INSTALL A CHASE ABOVE THE ROOF."
- y) Installation of any parts that contain openings that provide for air flow between air in the chimney chase and air located between the chimney walls.
- z) Installation and maintenance of a flashing/storm collar assembly. For a chimney assembly that incorporates a ventilated flashing, the instructions shall include specific details, in written and diagrammatic form:
- 1) Illustrating the openings in their intended location and orientation as installed; and
 - 2) Specifying precautions to be taken such as instructing the installer to not caulk or seal the ventilating openings.
- aa) An illustration and statement, for fireplaces for use in mobile homes, that the ceiling/roof thimble assembly shall extend completely through the ceiling/roof cavity of the mobile home to the outermost plane of the roof.

No Text on This Page