

SP1-13
105.3

Proposed Change as Submitted

Proponent: Jennifer Hatfield, J. Hatfield & Associates, PL, representing the Association of Pool & Spa Professionals (jhatfield@apsp.org)

Revise as follows:

105.3 Construction documents. *Construction documents*, engineering calculations, diagrams and other such data shall be submitted in two or more sets with each application for a *permit*. The *code official* shall require construction documents, computations and specifications to be prepared and designed by a registered design professional when required by state law. *Construction documents* shall be drawn to scale and shall be of sufficient clarity to indicate the location, nature and extent of the work proposed and show in detail that the work conforms to the provisions of this code. Manufacturer's instructions shall serve as *construction documents* for onground storable pools that are supplied by the manufacturer as a kit that includes all pipe, fittings and components.

Reason: This change is necessary because construction documents for these types of pools are the instruction manuals themselves, there are not other type of *construction documents*. Therefore, if an onground storable pool is found to fall within the scope of this code, this change will provide that a construction document can consist of the instruction manuals for a fully self-contained on-ground storable pool.

Cost Impact: The code change proposal will not increase the cost of construction.

105.3-SP-HATFIELD.DOC

Committee Action Hearing Results

Committee Action:

Disapproved

Committee Reason: The proposal was disapproved because it would limit the authority having jurisdiction from determining what constitutes acceptable construction documents for onground storable pools.

Assembly Action:

None

Individual Consideration Agenda

This item is on the agenda for individual consideration because a public comment was submitted.

Public Comment:

Jennifer Hatfield, J. Hatfield & Associates, PL, representing the Association of Pool & Spa Professionals requests Approval as Submitted.

Commenter's Reason: The public comment alleviates an unnecessary and potentially costly burden on homeowners who install onground storable pools sold as a complete kit. These pools include detailed manufacturer instructions as provided in APSP-4, which serve the same purpose as *construction documents* in ensuring safe and proper installation.

SP1-13

Final Action: AS AM AMPC____ D

SP3-13
202

Proposed Change as Submitted

Proponent: Jennifer Hatfield, J. Hatfield & Associates, PL, representing the Association of Pool & Spa Professionals (jhatfield@apsp.org)

Revise as follows:

AQUATIC VESSEL. A vessel, permanent or temporary, intended for swimming, bathing, or wading and that is designed and manufactured to be connected to a *circulation system*. ~~Portable vessels 12 inches (305 mm) or less in designed water depth which are drained and filled daily are not considered aquatic vessels.~~ For purposes of this code, the term is used to identify all the types of vessels governed by this code, including: swimming pools, aquatic facilities, *spas* and hot tubs, and related equipment. Such vessels are either used in a *residential* application or in a public application.

Reason: The sentence being removed is unnecessary and only adds confusion as it leads the reader to think that vessels over 12 inches in water depth are aquatic vessels. If an aquatic vessel has a circulation system, then it is an aquatic vessel, no matter what the depth is. Whereas there are, for example, 18 inch portable vessels that are drained and filled daily and do not have a circulation system.

Cost Impact: The code change proposal will not increase the cost of construction.

202-AQUATIC VESSEL #1-SP-HATFIELD.DOC

Committee Action Hearing Results

Committee Action:

Approved as Submitted

Committee Reason: The proposal was approved because the change makes an important clarification that the code only applies to pools and spas that have or are intended to have circulation systems.

Assembly Action:

None

Individual Consideration Agenda

This item is on the agenda for individual consideration because a public comment was submitted.

Public Comment:

Jennifer Hatfield, J. Hatfield & Associates, PL, representing the Association of Pool & Spa Professionals requests Disapproval.

Commenter's Reason: Although we are in agreement with the committee action for the original proposal, requesting disapproval because it may no longer be necessary if the public comment for SP 4 is approved.

SP3-13

Final Action:

AS

AM

AMPC ____

D

**SP4-13
202**

Proposed Change as Submitted

Proponent: Jennifer Hatfield, J. Hatfield & Associates, PL, representing the Association of Pool & Spa Professionals (jhatfield@apsp.org)

Revise as follows:

~~POOL AND SPA AQUATIC VESSEL.~~ A vessel, permanent or temporary, intended for swimming, bathing, or wading and that is designed and manufactured to be connected to a *circulation system*. Portable vessels 12 inches (305 mm) or less in designed water depth which are drained and filled daily are not considered aquatic vessels. For purposes of this code, the term is used to identify all the types of vessels governed by this code, including: *swimming pools, onground storable pools, aquatic recreation facilities, spas* and hot tubs, and related equipment. Such vessels are either used in a *residential* application or in a *public* application.

Reason: This proposal is being submitted due to the comments received from various I-code participants/users: builders, building departments, and others in the audience at the most recent I-code hearings for group A. There is a view that the term "aquatic vessel" is misleading or just not a good term because they associate it with a boat, not a pool. This concern resulted in a code proposal for the IBC, to reference the ISPSC and the new term, to not be adopted. Therefore, this proposal is offering a possible solution, to simply provide the term "pool and spa" to incorporate all the different pools and spas that exist.

Cost Impact: The code change proposal will not increase the cost of construction.

202-AQUATIC VESSEL #2-SP-HATFIELD.DOC

Committee Action Hearing Results

Committee Action:

Approved as Modified

Modify the proposal as follows:

~~POOL AND OR SPA.~~ A vessel, permanent or temporary, intended for swimming, bathing, or wading and that is designed and manufactured to be connected to a *circulation system*. Portable vessels 12 inches (305 mm) or less in designed water depth which are drained and filled daily are not considered aquatic vessels. For purposes of this code, the term is used to identify all the types of vessels governed by this code, including: *swimming pools, onground storable pools, aquatic recreation facilities, spas* and hot tubs, and related equipment. Such vessels are either used in a *residential* application or in a *public* application.

Committee Reason: The term "and" was changed to "or" because pools and spas are different constructions. There is not a construction that is both. The overall reason for approving the proposal was that the term "aquatic vessel" is misleading. The code needs to refer to these constructions by the names that are commonly used in the industry.

Assembly Action:

None

Individual Consideration Agenda

This item is on the agenda for individual consideration because a public comment was submitted.

Public Comment:

Jennifer Hatfield, J. Hatfield & Associates, PL, representing the Association of Pool & Spa Professionals requests Approval as Modified by this Public Comment

Further modify the proposal as follows:

Revise text as follows:

POOL OR SPA. A vessel, permanent or temporary, intended for swimming, bathing, or wading and that is designed and manufactured to be connected to a *circulation system*. Portable vessels 12 inches (305 mm) or less in designed water depth which are drained and filled daily are not considered aquatic vessels. For purposes of this code, the term is used to identify all the types of vessels governed by this code, including: *swimming pools, onground storable pools, aquatic recreation facilities, spas* and hot tubs, and related equipment. Such vessels are either used in a *residential* application or in a *public* application.

101.2 Scope. The provisions of this code shall apply to the construction, alteration, movement, renovation, replacement, repair and maintenance of *aquatic vessels aquatic recreation facilities, pools and spas*. The pools and spas covered by this code are either permanent or temporary, and shall be only those that are designed and manufactured to be connected to a circulation system and that are intended for swimming, bathing, or wading.

102.6 Moved aquatic vessels pools and spas. Except as determined by Section 102.2, systems that are a part of *aquatic vessels pools or spas* or systems moved into or within the *jurisdiction* shall comply with the provisions of this code for new installations.

BACKWASH CYCLE. The time required to *backwash* the filter medium and/or elements and to remove debris in the pool or spa filter vessel.

BARRIER. A permanent fence, wall, building wall, or combination thereof that completely surrounds the aquatic vessels pool or spa and obstructs the access to the vessel pool or spa. Permanent shall mean "not being able to be removed, lifted, or relocated without the use of a tool."

EXERCISE SPA (Also known as a swim spa). Variants of a *spa* in which the design and construction includes specific features and equipment to produce a water flow intended to allow recreational physical activity including, but not limited to, swimming in place. Exercise *spas* can include peripheral jetted seats intended for water therapy, heater, circulation and *filtration* system, or can be a separate distinct portion of a combination spa/exercise spa and can have separate controls. These *aquatic vessels spas* are of a design and size such that it has an unobstructed volume of water large enough to allow the 99th Percentile Man as specified in APSP 16 to swim or exercise in place.

NONENTRY AREA. An area of the deck from which entry into the vessel pool or spa is not permitted.

SWIMMING POOL. See "*public swimming pool*" and "*residential swimming pool*."

301.1 Scope. The provisions of this chapter shall govern the general design and construction of *public and residential aquatic vessels pools and spas* and all related piping, equipment, and materials. Provisions that are unique to a specific type of *aquatic vessels pool or spa* are located in Chapters 4 through 10.

304.2.1 Aquatic vessels Pools and spas located in designated floodways. Where *aquatic vessels pools and spas* are located in designated floodways, documentation shall be submitted to the *code official* that demonstrates that the construction of the *aquatic vessel pools or spas* will not increase the design flood elevation at any point within the jurisdiction.

304.2.2 Aquatic vessels Pools and spas located where floodways have not been designated. Where *aquatic vessels pools or spas* are located where design flood elevations are specified but floodways have not been designated, the applicant shall provide a floodway analysis that demonstrates that the proposed *aquatic vessel pools or spas* and any associated grading and filling, will not increase the design flood elevation more than 1 foot (305 mm) at any point within the jurisdiction.

305.1 General. The provisions of this section shall apply to the design of *barriers* for *aquatic vessels pools and spas*. These design controls are intended to provide protection against the potential drowning and near drowning by restricting access to such vessels pools or spas. These requirements provide an integrated level of protection against potential drowning through the use of physical barriers and warning devices.

Exceptions:

1. *Spas* and hot tubs with a lockable safety cover that complies with ASTM F 1346.
2. Swimming pools with a *powered safety cover* that complies with ASTM F 1346.

305.2.1 Barrier height and clearances. Barrier heights and clearances shall be in accordance with all of the following:

1. The top of the *barrier* shall be not less than 48 inches (1219 mm) above grade where measured on the side of the *barrier* that faces away from the *aquatic vessel pool or spa*. Such height shall exist around the entire perimeter of the *vessel pool or spa* and for a distance of 3 feet (914 mm) where measured horizontally from the required *barrier*.
2. The vertical clearance between grade and the bottom of the *barrier* shall not exceed 2 inches (51 mm) for grade surfaces that are not solid, such as grass or gravel, where measured on the side of the barrier that faces away from the *vessel pool or spa*.
3. The vertical clearance between a surface below the barrier to a solid surface, such as concrete, and the bottom of the required *barrier* shall not exceed 4 inches (102 mm) where measured on the side of the required barrier that faces away from the *vessel pool or spa*.
4. Where the top of the *vessel pool or spa* structure is above grade, the *barrier* shall be installed on grade or shall be mounted on top of the *vessel pool or spa* structure. Where the *barrier* is mounted on the top of the *vessel pool or spa*, the vertical clearance between the top of the *vessel pool or spa* and the bottom of the *barrier* shall not exceed 4 inches (102 mm).

305.3 Gates. Access gates shall comply with the requirements of Sections 305.3.1 through 305.3.3 and shall be equipped to accommodate a locking device. Pedestrian access gates shall open outward away from the ~~vessel~~ pool or spa and shall be self-closing and have a self-latching device.

305.3.3 Latches. Where the release mechanism of the self-latching device is located less than 54 inches (1372 mm) from grade, the release mechanism shall be located on the ~~vessel~~ pool or spa side of the gate at least 3 inches (76 mm) below the top of the gate, and the gate and *barrier* shall not have openings greater than 1/2 inch (12.7 mm) within 18 inches (457 mm) of the release mechanism.

305.6 Natural barriers. In the case where the ~~vessel~~ pool or spa area abuts the edge of a lake or other natural body of water, public access is not permitted or allowed along the shoreline, and required *barriers* extend to and beyond the water's edge a minimum of 18 inches (457 mm), a *barrier* is not required between the natural body of water shoreline and the ~~vessel~~ pool or spa.

307.7 Colors and finishes. The colors, patterns, or finishes of the ~~vessel~~ pool or spa interior shall not obscure objects or surfaces within the ~~vessel~~ pool or spa.

Exception: *Residential pools and spas.*

307.8 Roofs or canopies. Roofs or canopies over ~~aquatic-vessels~~ pools and spas shall be in accordance with the *International Building Code* or *International Residential Code*, as applicable in accordance with Section 102.7.1 and shall be constructed so as to prevent water runoff into the ~~aquatic-vessel~~ pool or spa.

307.9 Accessibility. An accessible route to the public ~~aquatic-vessels~~ pool or spa shall be provided in accordance with the *International Building Code*. Accessibility within the public ~~aquatic-vessels~~ pool or spa shall be provided as required by the accessible recreational facilities provisions of the *International Building Code*. Accessibility for ~~aquatic-vessels~~ pools and spas accessory to detached one- and two-family dwellings and townhouses not more than three stories in height shall be provided where required by the *International Residential Code*.

319.2 Chemical feeders. Where installed, chemical feed systems shall be installed in accordance with the manufacturer's specifications. Chemical feed pumps shall be wired so that they cannot operate unless there is adequate return flow to disburse the chemical throughout the ~~vessel~~ pool or spa as designed.

321.1 General. The provisions of Sections 321.2 and 321.3 apply to lighting for public ~~aquatic-vessels~~ pools and spas. The provisions of Section 321.4 shall apply to *lighting for residential aquatic-vessels* pools or spas.

608.1 Occupant load. The occupant load for the ~~aquatic-vessels~~ pools or spas in the facility shall be calculated in accordance with Table 608.1. The occupant load shall be the combined total of the number of users based on the ~~vessel~~ pool or spa water surface area and the deck area surrounding the ~~vessel~~ pool or spa. The deck area occupant load shall be based on the occupant load calculated where a deck is provided or based on an assumed 4-foot-wide (1219 mm) deck surrounding the entire perimeter of the ~~vessel~~ pool or spa, whichever is greater.

610.6 Swimouts. *Swimouts* shall be located completely outside of the water current or wave action of the ~~aquatic-vessel~~ pool or spa and can be located in shallow or deep areas of water.

801.1 Scope. The provisions of this chapter shall govern permanent inground *residential swimming pools* that are installed for *residential* use. This chapter covers new construction, modification or ~~repair and residential aquatic vessels~~.

Throughout the following sections of the code, replace the term “aquatic vessel(s)” with “pool(s) or spa(s)”:

102.2
102.4
102.5
104.2
105.1
107.3
107.4
107.6
107.7.2
108.2.1
Section 202, under the following defined terms: “alteration”, “existing aquatic vessel”, “repair”
305.2.5
305.2.10
305.4
305.7
308.3
309.1
311.2.1
311.4
311.9

313.7
322.1
323.1
409.2.2

Throughout the following sections of the code, replace the term “*aquatic vessel(s)*” with “*pool(s) and spa(s)*”:

101.3
102.3
106.3
302.2
302.5
302.6
302.8
304.1
304.2
304.3
305.2
307.1
307.3
307.4
307.4.1
307.5
307.6
308.4
310.1
311.1
311.2
311.2.3
312.1
313.1
313.3
314.1
315.1
315.2
Table 315.3
315.4
316.1
316.4.2
317.1
319.1
607.1
608.2

Commenter’s Reason: Even though the committee approved changing ‘aquatic vessel’ to ‘pool or spa’, it is still essential that the term ‘aquatic vessel’ be replaced in the remaining chapters to ‘pool or spa’ each of the many times it appears. That is why numerous sections are addressed in this single Public Comment. Otherwise there would be wide spread confusion in the pool industry and inspectors will have a difficult time enforcing the code. Therefore, we cannot afford to disapprove this proposal because we must eliminate ‘aquatic vessel.’ The committee was in agreement with that. This public comment provides for the complete path to properly eliminate the ‘aquatic vessel’ term and to ensure that the more common term, “pool or spa” or “pool and spa” or just “spa” is inserted as appropriate throughout the code. The definition “pool or spa” is deleted because what is defined has either been moved to the scope section of the code or already exists within definitions that already exist in Chapter 2, i.e. “pool,” “residential swimming pool,” “public swimming pool,” “spa,” and “aquatic recreation facility.”

SP4-13

Final Action: AS AM AMPC_____ D

SP12-13
202, 405.1

Proposed Change as Submitted

Proponent: Jennifer Hatfield, J. Hatfield & Associates, PL, representing the Association of Pool & Spa Professionals (jhatfield@apsp.org)

Revise as follows:

PUBLIC POOL.

CLASS A, COMPETITION POOL. A pool intended for use for accredited competitive aquatic events such as Federation Internationale De Natation (FINA), USA Swimming, USA Diving, USA Synchronized Swimming, USA Water Polo, National Collegiate Athletic Association(NCAA), National Federation of State High School Associations(NFHS). ~~The use of the Such pools are often used for recreation and other water activities~~ in addition to ~~is not limited to~~ competitive events.

CLASS B, PUBLIC POOL. A pool intended for public recreational use that is not identified in the other classifications of public pools.

CLASS F. Class F pools are wading pools and are covered within the scope of this code as set forth in Section 405.

405.1 Wading pools. Class F wading pools shall be separate pools with an independent *circulation system* and shall be physically separated from the main pool. Such wading pools shall be constructed in accordance with Sections 405.2 through 405.6.

Reason: : A definition of wading pool was missing from the current ISPSC edition and this terminology follows the APSP-1 standard re-write on defining a wading pool as CLASS F and referencing the section of the standard that provides the specific requirements for the wading pool. Also updated CLASS A and CLASS B, per the APSP-1 rewrite.

Cost Impact: The code change proposal will not increase the cost of construction

202-PUBLIC SWIMMING POOL-SP-HATFIELD

Committee Action Hearing Results

Committee Action:

Disapproved

Committee Reason: The last sentence for Class A, competition pool contains the word "often". Those pools might not ever be used for recreation and other water activities.

Assembly Action:

None

Individual Consideration Agenda

This item is on the agenda for individual consideration because a public comment was submitted.

Public Comment:

Jennifer Hatfield, J. Hatfield & Associates, PL, representing the Association of Pool & Spa Professionals requests Approval as Modified by this Public Comment.

Modify proposal as follows:

PUBLIC POOL.

CLASS A, COMPETITION POOL. A pool intended for use for accredited competitive aquatic events such as Federation Internationale De Natation (FINA), USA Swimming, USA Diving, USA Synchronized Swimming, USA Water Polo, National Collegiate Athletic Association (NCAA), National Federation of State High School Associations (NFHS). ~~Such pools are often used for recreation and other water activities and in addition to competitive events.~~

405.1 Wading pools. *Class F* wading pools shall be separate pools with an independent *circulation system*, ~~and~~ shall be physically separated from the main pool, ~~and~~. ~~Wading pools~~ shall be constructed in accordance with Sections 405.2 through 405.6.

Commenter's Reason: The committee disapproved this code change due to wording within the original proposal that included "such" and "often," which was deemed by the committee as poor code language. The public comment removes that language and retains the intent of the original proposal. The last line in the Class A definition is not needed because it is commentary.

SP12-13

Final Action: AS AM AMPC____ D

SP13-13
202

Proposed Change as Submitted

Proponent: Jennifer Hatfield, J. Hatfield & Associates, PL, representing the Association of Pool & Spa Professionals (jhatfield@apsp.org)

Revise as follows:

SAFETY COVER. ~~A barrier intended to be completely removed before entry of users for swimming pools, spas, hot tubs or wading pools, attendant appurtenances and/or anchoring mechanisms that will, when properly labeled, installed, used, and maintained in accordance with the manufacturer's published instructions. These covers are either a power or manual type. A structure, fabric or assembly, along with attendant appurtenances and anchoring mechanisms, that is temporarily placed or installed over an entire pool, spa or hot tub and secured in place after all bathers are absent from the water. A safety cover is intended to be completely removed before users enter the pool, spa or hot tub. A safety cover is not complete unless the placement, installation, securing and maintenance of such covers is in accordance with the manufacturer's instructions. The primary purpose for installation of a safety cover is to inhibit access to the contained body of water by children under five years of age so as to reduce the risk of drowning. Safety covers are designed to limit the amount of water, such as from rainwater and snowmelt, that could collect on the surface of the cover so as to reduce the risk of children drowning in the collected water. Such covers are either a power type or a manual type.~~

Reason: Currently does not follow the ASTM F 1346 cover standard definition (see Section 3.1.17) for safety cover and as currently written the sentence does not make sense. The changes above align with the ASTM standard and address the concern that the term "labeled" would be confused with "listed and labeled".

Cost Impact: The code change proposal will not increase the cost of construction.

202-SAFETY COVER-SP-HATFIELD.DOC

Committee Action Hearing Results

Committee Action:

Disapproved

Committee Reason: The definition is much too long. The first sentence says what needs to be said for this term. The remainder of the wording should be, if necessary, put into the body of the code. Definitions need to be short and concise.

Assembly Action:

None

Individual Consideration Agenda

This item is on the agenda for individual consideration because a public comment was submitted.

Public Comment:

Jennifer Hatfield, J. Hatfield & Associates, PL, representing the Association of Pool & Spa Professionals requests Approval as Modified by this Public Comment.

Modify the proposal as follows:

SAFETY COVER. A structure, fabric or assembly, along with attendant appurtenances and anchoring mechanisms, that is temporarily placed or installed over an entire pool, spa or hot tub and secured in place after all bathers are absent from the water. A safety cover is intended to be completely removed before users enter the pool, spa or hot tub. A safety cover is not complete unless the placement, installation, securing and maintenance of such covers is in accordance with the manufacturer's instructions. The primary purpose for installation of a safety cover is to inhibit access to the contained body of water by children under five years of

~~age so as to reduce the risk of drowning. Safety covers are designed to limit the amount of water, such as from rainwater and snowmelt, that could collect on the surface of the cover so as to reduce the risk of children drowning in the collected water. Such covers are either a power type or a manual type.~~

Commenter's Reason: The public comment addresses the committee's reason for disapproval, which was that the definition was too long. The wording that remains will provide the aim of the original proposal, which was to ensure consistency with the ASTM F 1346, 1991 edition, of the cover standard manufacturers must follow.

SP13-13

Final Action: AS AM AMPC____ D

SP19-13, Part I

303.1

Proposed Change as Submitted

Proponent: Jennifer Hatfield, J. Hatfield & Associates, PL, representing the Association of Pool & Spa Professionals (jhatfield@apsp.org)

THIS IS A 3 PART CODE CHANGE. PART I WILL BE HEARD BY THE ISPSC COMMITTEE, Part II WILL BE HEARD BY THE IECC-CE COMMITTEE, PART III WILL BE HEARD BY THE IECC-RE COMMITTEE. SEE THE TENTATIVE HEARING ORDERS FOR THESE COMMITTEES.

PART I - ISPSC

Revise as follows:

303.1 General Pool and spa energy consumption. The energy ~~consumption of requirements~~ for pools and ~~inground permanently installed permanent residential spas~~ shall be controlled by the requirements as specified in Sections 303.2 1.1 through 303.1.4, and APSP 15. ~~The energy requirements for residential portable electric spas shall be in accordance with APSP 14.~~

303.1.1 Residential pools and permanent residential spas. Residential swimming pools and permanent residential spas shall be in accordance with APSP-15.

303.1.2 Heaters. The electric power to heaters shall be ~~equipped with~~ controlled by an readily accessible external on-off switch that is mounted on the exterior of the heater or external to and within 3 feet (914 mm) of the heater. Operation of such switch shall not change the setting of the heater thermostat. Such switches shall be in addition to a circuit breaker for the power to the heater, to allow the heater to be shutoff without adjusting the thermostat setting. ~~Such switch shall be provided with ready access.~~ Gas-fired heaters shall not be equipped with ~~continuous pilot burners~~ continuously-burning ignition pilots.

Exception: ~~Portable residential spas and portable residential exercise spas.~~

303.1.3 Time switches. Time switches or other control methods that can automatically turn off and on heaters and pumps motors according to a preset schedule shall be installed ~~with for on all heaters and pump motors.~~ Heaters ~~and,~~ pumps ~~and~~ motors that have built-in timers switches shall be ~~deemed in compliance with this section requirement.~~

Exceptions:

1. Where public health standards require 24-hour pump operation.
2. Pumps that operate solar- or waste-heat recovery pool heating systems.
3. ~~Portable residential spas and portable residential exercise spas.~~

303.1.4 Covers. Outdoor heated pools and outdoor inground permanently installed permanent residential spas shall be provided with a vapor retardant cover, a liquid cover or other approved vapor retardant means in accordance with 104.11.

Exception: Where more than 70 percent of the energy for heating, computed over an operating season, is from site-recovered energy such as from a heat pump or solar energy source, covers or other vapor retardant means shall not be required.

303.2 Portable residential spas. The energy consumption of electric-powered portable residential spas shall be controlled by the requirements of APSP 14.

Reason:

PART I: This code change provides for the following:

1. All parts work to provide consistent language with pool and spa energy provisions found in the ISPSC and IECC. Some portions have been added here that were already included in the ISPSC and vice versa on part II and III of this proposal below.
2. Clarifies APSP-15 only applies to residential pools and inground spas.
3. Changes wording to use defined terms, as found in Chapter 2 of the ISPSC.
4. Clarifications regarding on-off switches for heaters.
6. Consistent verbiage within the time switch requirements.
7. Provides for clarity that the cover requirements are only for outdoor pools.
8. Provides for options when it comes to pool and spa covers to ensure one can comply with more intricately designed pools and spas (shape, size/infinity pools/etc.). Otherwise if only one type of method can be used then the code is limiting the design of any pool or spa. The "typical" rectangle pool is no longer the norm.

Cost impact: These code change proposals will not increase the cost of construction.

Analysis: Standards APSP 14 and APSP-15 are in the 2012 ISPSC.

303.1-SP-HATFIELD.DOC

Committee Action Hearing Results

The code change is contained in the [Updates to the 2013 Proposed Changes](http://www.iccsafe.org/cs/codes/Documents/2012-2014Cycle/Proposed-B/00-CompleteGroupB-MonographUpdates.pdf) posted on the ICC website. Please go to <http://www.iccsafe.org/cs/codes/Documents/2012-2014Cycle/Proposed-B/00-CompleteGroupB-MonographUpdates.pdf> for more information.

PART I – ISPSC

Heard by the ISPSC Committee

Committee Action:

Disapproved

Committee Reason: The proposal was disapproved because it does not give credit to heaters that have on-off switches integral to the product. Shutting off power to some controls might cause the control to revert back to factory settings. Covers are only required for outdoor pools and spas. Indoor pools and spas should also have covers. Liquid covers are relatively new but there are no standards for this type of product. A standard for this product should be available before it is required by the code.

Assembly Action:

None

Individual Consideration Agenda

This item is on the agenda for individual consideration because a public comment was submitted.

Public Comment:

Jennifer Hatfield, J. Hatfield & Associates, PL, representing the Association of Pool & Spa Professionals requests Approval as Modified by this Public Comment.

Modify the proposal as follows:

303.1 Energy consumption of pools and permanent spas. The energy consumption of pools and *permanent residential spas* shall be controlled by the requirements in Sections 303.1.1 through 303.1.4~~3~~.

303.1.1 Residential pools and permanent residential spas. ~~Residential swimming pools and permanent residential spas shall be in accordance with APSP-15.~~

303.1.21 Heaters. The electric power to heaters shall be controlled by a readily accessible on-off switch that is an integral part of the heater, mounted on the exterior of the heater or external to and within 3 feet (914 mm) of the heater. Operation of such switch shall not change the setting of the heater thermostat. Such switches shall be in addition to a circuit breaker for the power to the heater. Gas-fired heaters shall not be equipped with continuously-burning ignition pilots.

303.1.32 Time switches. Time switches or other control methods that can automatically turn off and on heaters and pump motors according to a preset schedule shall be installed for heaters and pump motors. Heaters and pump motors that have built-in timer switches shall be deemed in compliance with this section.

Exceptions:

1. Where public health standards require 24-hour pump operation.
2. Pumps that operate solar- or waste-heat recovery pool heating systems.

303.1.43 Covers. Outdoor heated pools and outdoor *permanent residential spas* shall be provided with a vapor retardant cover, a liquid cover or other *approved* vapor retardant means in accordance with Section 104.11.

Exception: Where more than 70 percent of the energy for heating, computed over an operating season, is from site-recovered energy such as from a heat pump or solar energy source, covers or other vapor retardant means shall not be required.

303.2 Portable residential spas. The energy consumption of electric-powered *portable residential spas* shall be controlled by the requirements of APSP 14.

303.3 Residential pools and permanent residential spas. The energy consumption of residential swimming pools and permanent residential spas shall be controlled in accordance with the requirements of APSP 15.

Commenter's Reason: As it stands now there are inconsistent energy efficiency requirements between the IECC and ISPSC, which is why this three part public comment is essential to ensure that these codes are consistent with ANSI approved APSP Standards. Otherwise code officials, owners, manufacturers and installers will be faced with conflicting and possibly incompatible language. The public comment addresses the ISPSC committee's concerns, some of which was addressed in the IECC parts of the proposal in Dallas by floor modification after the input received by the ISPSC committee under Part I. This public comment implements those IECC changes to the ISPSC (Part I) portion of the proposal, but makes further clarifications to all parts to ensure the two I-codes have consistent energy efficient requirements for pools and spas.

Specifically in regards to Part I of the proposal, the public comment addresses the ISPSC committees reason for disapproval by a) adding in the integral on and off switches for heaters (already done in the IECC), b) removing the specific reference to a liquid cover, and allowing the AHJ to determine what other "approved vapor retardant means" can be used consistent with Chapter 1 (already done in the IECC), and 3) clarifying which provisions apply to public as opposed to residential *pools or permanent spas or portable spas*. This last aspect is critical to ensure it is only residential pools and spas that must meet the APSP Standard, as intended by the Standard, and the remaining portions are for both public and residential.

Part II of the proposal simply modifies the committee action by correcting a section reference. Part III of the proposal clarifies what provisions apply to public versus residential *pools as opposed to permanent spas or portable spas* – ensuring consistency between the respective Codes and the APSP Standard, following the proposed modifications under Part I.

SP19-13, Part I

Final Action: AS AM AMPC_____ D

SP19-13, Part II

IECC C404.7, C404.7.1, C404.7.2, C404.7.3, C404.8, Chapter 5

Proposed Change as Submitted

Proponent: Jennifer Hatfield, J. Hatfield & Associates, PL, representing the Association of Pool & Spa Professionals (jhatfield@apsp.org)

THIS IS A 3 PART CODE CHANGE. PART I WILL BE HEARD BY THE ISPSC COMMITTEE, Part II WILL BE HEARD BY THE IECC-CE COMMITTEE, PART III WILL BE HEARD BY THE IECC-RE COMMITTEE. SEE THE TENTATIVE HEARING ORDERS FOR THESE COMMITTEES.

PART II - IECC-COMMERCIAL PROVISIONS

Revise as follows:

C404.7 Pools and spa energy consumption inground permanently installed spas. (Mandatory). Pools and inground permanently installed spas shall comply with Sections C404.7.1 through C404.7.3. The energy consumption of pools and inground permanent residential spas shall be controlled by the requirements in Sections C404.7.1 through C404.7.4.

C404.7.1 Heaters. The electric power to all heaters shall be ~~equipped with~~ controlled by an readily accessible external on-off switch that is mounted on the exterior of the heater or external to and within 3 feet (914 mm) of the heater. Operation of such switch shall not change the setting of the heater thermostat. Such switches shall be in addition to a circuit breaker for the power to the heater. ~~to allow the heater to be shutoff without adjusting the thermostat setting.~~ Such switch shall be provided with ready access. Gas-fired heaters shall not be equipped with ~~continuous pilot burners~~ continuously-burning ignition pilots.

Exception: ~~Portable residential spas and portable residential exercise spas.~~

C404.7.2 Time switches. Time switches or other control methods that can automatically turn off and on heaters and pump motors according to a preset schedule shall be installed ~~with~~ for on all heaters and pump motors. Heaters and, pumps and motors that have built-in timers switches shall be deemed in compliance with this section requirement.

Exceptions:

1. Where public health standards require 24-hour pump operation.
2. ~~Where~~ Pumps that are required to operate solar- and waste-heat-recovery pool heating systems.

C404.7.3 Covers. Outdoor heated pools and outdoor inground permanently installed permanent residential spas shall be provided with a vapor retardant cover, a liquid cover or other approved vapor retardant means.

Exception: ~~A vapor-retardant cover is not required for pools deriving over 70 percent of the energy for heating from site-recovered energy, such as a heat pump or solar energy source computed over an operating season. Where more than 70 percent of the energy for heating, computed over an operating season, is from site-recovered energy such as from a heat pump or solar energy source, covers or other vapor retardant means shall not be required.~~

C404.8 Portable residential spas (Mandatory). The energy consumption of electric-powered portable residential spas shall be controlled by the requirements of APSP 14.

Add new standard to Chapter 5:

The Association of Pool & Spa Professionals
2111 Eisenhower Avenue
Alexandria, VA 22314

APSP

14-11 American National Standard for Portable Electric Spa Efficiency

Reason:

PART II Reason: This code change provides for the following:

1. All parts work to provide consistent language with pool and spa energy provisions found in the ISPSC and IECC. Some portions have been added here that were already included in the ISPSC and vice versa on part II and III of this proposal below.
2. Changes wording to use defined terms, as found in Chapter 2 of the ISPSC.
3. Clarifications regarding on-off switches for heaters.
4. Consistent verbiage within the time switch requirements.
5. Provides for clarity that the cover requirements are only for outdoor pools.
6. Provides for options when it comes to pool and spa covers to ensure one can comply with more intricately designed pools and spas (shape, size/infinity pools/etc.). Otherwise if only one type of method can be used then the code is limiting the design of any pool or spa. The "typical" rectangle pool is no longer the norm.
7. Provides for a new subsection to address portable residential spas in the rare case they would be used for more than a four story building and therefore fall under the commercial code.

Cost impact: These code change proposals will not increase the cost of construction.

Analysis: Standards APSP 14 and APSP-15 are in the 2012 ISPSC.

303.1-SP-HATFIELD.DOC

Committee Action Hearing Results

The code change is contained in the Updates to the 2013 Proposed Changes posted on the ICC website. Please go to <http://www.iccsafe.org/cs/codes/Documents/2012-2014Cycle/Proposed-B/00-CompleteGroupB-MonographUpdates.pdf> for more information.

PART II – IECC - Commercial

Heard by the IECC-Commercial Provisions Committee

Committee Action:

Approved as Modified

Modify the proposal as follows:

C404.7 Pools and permanent spa energy consumption (Mandatory). The energy consumption of pools and permanent residential spas shall be controlled by the requirements in Sections C404.7.1 through C404.7.4.

C404.7.1 Heaters. The electric power to heaters shall be controlled by a readily accessible on-off switch that is an integral part of the heater, mounted on the exterior of the heater or external to and within 3 feet (914 mm) of the heater. Operation of such switch shall not change the setting of the heater thermostat. Such switches shall be in addition to a circuit breaker for the power to the heater. Gas-fired heaters shall not be equipped with continuously-burning ignition pilots.

C404.7.2 Time switches. Time switches or other control methods that can automatically turn off and on heaters and pump motors according to a preset schedule shall be installed for heaters and pump motors. Heaters and pump motors that have built-in time switches shall be in compliance with this section.

Exceptions:

1. Where public health standards require 24-hour pump operation.
2. Pumps that operate solar- and waste-heat-recovery pool heating systems.

C404.7.3 Covers. Outdoor heated pools and outdoor permanent residential spas shall be provided with a vapor retardant

cover, a liquid cover or other *approved* vapor retardant means.

Exception: Where more than 70 percent of the energy for heating, computed over an operating season, is from site-recovered energy such as from a heat pump or solar energy source, covers or other vapor retardant means shall not be required.

C404.8 Portable residential spas (Mandatory). The energy consumption of electric-powered portable residential spas shall be controlled by the requirements of APSP 14.

Committee Reason: The reason for making the modification is that this limits the energy requirements to permanent spas only. The reason for approving the overall proposal is that the proposal coordinates the energy requirements between the IECC and the ISPS.

Assembly Action: _____ **None**

Individual Consideration Agenda

This item is on the agenda for individual consideration because public comments were submitted.

Public Comment 1:

Jennifer Hatfield, J. Hatfield & Associates, PL, representing the Association of Pool & Spa Professionals requests Approval as Modified by this Public Comment.

Further modify the proposal as follows:

C404.7 Energy consumption of pools and permanent spas (Mandatory). The energy consumption of pools and permanent spas shall be controlled by the requirements in Sections C404.7.1 through C404.7.43.

Commenter's Reason: This public comment simply modifies the committee action by fixing a section reference. There is not a Section C404.7.4.

Public Comment 2:

Edward R. Osann, Natural Resources Defense Council on behalf of self (eosann@nrdc.org) requests Approval as Modified by this Public Comment

Further modify the proposal as follows:

C404.7.3 Covers. ~~Outdoor~~ Heated pools and outdoor permanent spas shall be provided with a vapor retardant cover or other *approved* vapor retardant means.

Exception: Where more than 70 percent of the energy for heating, computed over an operating season, is from site-recovered energy such as from a heat pump or solar energy source, covers or other vapor retardant means shall not be required.

Commenter's Reason: Without explanation or justification, the proposal as submitted would weaken current code language by removing the requirement that a pool cover be provided for all heated pools, whether located indoors or out. There is important value provided by a cover for an indoor pool, including humidity management, which has important energy implications. The modification in this comment would restore the current requirement that new heated indoor pools be provided with a vapor retardant cover.

SP19-13, Part II

Final Action: AS AM AMPC _____ D

SP19-13, Part III

ECC R403.9 (IRC N1104.9), R403.9.1 (New) (IRC N1104.9.1 (New)), R403.9.2 (IRC N1104.9.2), R403.9.3 (IRC N1104.9.1.3), R403.9.4 (IRC N1104.9.1.4), R403.10 (New) (IRC N1103.10 (New)), Chapter 5 (IRC Chapter 44)

Proposed Change as Submitted

Proponent: Jennifer Hatfield, J. Hatfield & Associates, PL, representing the Association of Pool & Spa Professionals (jhatfield@apsp.org)

THIS IS A 3 PART CODE CHANGE. PART I WILL BE HEARD BY THE ISPSC COMMITTEE, Part II WILL BE HEARD BY THE IECC-CE COMMITTEE, PART III WILL BE HEARD BY THE IECC-RE COMMITTEE. SEE THE TENTATIVE HEARING ORDERS FOR THESE COMMITTEES.

Part III - IECC-Residential Provisions

Revise as follows:

R403.9 (N1104.9) Pools and spa energy consumption inground permanently installed spas. (Mandatory). ~~Pools and inground permanently installed spas shall comply with Sections R403.9.1 through R403.9.3. The energy consumption of pools and inground permanent residential spas shall be controlled by the requirements in Sections R403.9.1 through R403.9.4.~~

R403.9.1 Residential pools and permanent residential spas. ~~Swimming pools and permanent spas that are accessory to detached one- and two- family dwellings and townhouses 3 stories or less in height above ground plane and that are available only to the household and its guests shall be in accordance with APSP-15.~~

R403.9.2 (N1104.9.2) Heaters. ~~The electric power to heaters shall be equipped with controlled by an readily accessible external on-off switch that is mounted on the exterior of the heater or external to and within 3 feet (914 mm) of the heater. Operation of such switch shall not change the setting of the heater thermostat. Such switches shall be in addition to a circuit breaker for the power to the heater. to allow the heater to be shutoff without adjusting the thermostat setting. Such switch shall be provided with ready access. Gas-fired heaters shall not be equipped with continuous pilot burners continuously-burning ignition pilots.~~

R403.9.3 (N1104.9.3) Time switches. ~~Time switches or other control methods that can automatically turn off and on heaters and pump motors according to a preset schedule shall be installed with for on all heaters and pump motors. Heaters and, pumps and motors that have built-in timers switches shall be deemed in compliance with this section requirement.~~

Exceptions:

1. Where public health standards require 24-hour pump operation.
2. ~~Where~~ Pumps that are required to operate solar- and waste-heat-recovery pool heating systems.

R403.9.4 (N1104.9.4) Covers. ~~Outdoor heated pools and outdoor inground permanently installed permanent residential spas shall be provided with a vapor retardant cover, a liquid cover or other approved vapor retardant means.~~

Exception: ~~A vapor-retardant cover is not required for pools deriving over 70 percent of the energy for heating from site-recovered energy, such as a heat pump or solar energy source computed over an operating season. Where more than 70 percent of the energy for heating, computed over an~~

operating season, is from site-recovered energy such as from a heat pump or solar energy source, covers or other vapor retardant means shall not be required.

R403.10 (N1103.10) Portable residential spas (Mandatory). The energy consumption of electric-powered portable residential spas shall be controlled by the requirements of APSP 14.

Add new standards to Chapter 5 (IRC Chapter 44):

The Association of Pool & Spa Professionals
2111 Eisenhower Avenue
Alexandria, VA 22314

APSP

14-11 American National Standard for Portable Electric Spa Efficiency

15-11 American National Standard for Residential Swimming Pool and Spa Energy Efficiency

Reason:

PART III Reason: This code change provides for the following:

1. All parts work to provide consistent language with pool and spa energy provisions found in the ISPSC and IECC. Some portions have been added here that were already included in the ISPSC and vice versa on part II and III of this proposal below.
2. Clarifies APSP-15 only applies to residential pools and inground spas.
3. Changes wording to use defined terms, as found in Chapter 2 of the ISPSC.
4. Clarifications regarding on-off switches for heaters.
5. Consistent verbiage within the time switch requirements.
6. Provides for clarity that the cover requirements are only for outdoor pools.
7. Provides for options when it comes to pool and spa covers to ensure one can comply with more intricately designed pools and spas (shape, size/infinity pools/etc.). Otherwise if only one type of method can be used then the code is limiting the design of any pool or spa. The "typical" rectangle pool is no longer the norm.
8. Provides for a new subsection to address portable residential spas, requiring their compliance with the APSP-14 energy standard, consistent with the ISPSC.

Cost impact: These code change proposals will not increase the cost of construction.

Analysis: Standards APSP 14 and APSP-15 are in the 2012 ISPSC.

303.1-SP-HATFIELD.DOC

Committee Action Hearing Results

The code change is contained in the Updates to the 2013 Proposed Changes posted on the ICC website. Please go to <http://www.iccsafe.org/cs/codes/Documents/2012-2014Cycle/Proposed-B/00-CompleteGroupB-MonographUpdates.pdf> for more information.

PART III – IECC – Residential

Heard by the IECC-Residential Provisions Committee

Committee Action:

Approved as Modified

Modify the proposal as follows:

R403.9 (N1104.9) Pools and permanent spa energy consumption (Mandatory). The energy consumption of pools and permanent residential spas shall be controlled by the requirements in Sections R403.9.1 through R403.9.4 9.3.

Exception: ~~R403.9.1 Residential pools and permanent residential spas.~~ Heaters and time switches for swimming pools and permanent spas that are accessory to detached one- and two- family dwellings and townhouses 3 stories or less in height above ground plane and that are available only to the household and its guests shall be in accordance with APSP-15.

R403.9.2 1 (N1104.9.2 1) Heaters. The electric power to heaters shall be controlled by a readily accessible on-off switch that is an

integral part of the heater, mounted on the exterior of the heater or external to and within 3 feet (914 mm) of the heater. Operation of such switch shall not change the setting of the heater thermostat. Such switches shall be in addition to a circuit breaker for the power to the heater. Gas-fired heaters shall not be equipped with continuously-burning ignition pilots.

R403.9.3 ~~2~~ (N1104.9-3 2) Time switches. Time switches or other control methods that can automatically turn off and on heaters and pump motors according to a preset schedule shall be installed for ~~on all~~ heaters and pump motors. Heaters and pumps and motors that have built-in time switches shall be in compliance with this section.

Exceptions:

1. Where public health standards require 24-hour pump operation.
2. Pumps that operate solar- and waste-heat-recovery pool heating systems.

R403.9.4 ~~9.3~~ (N1104.9.4 ~~9.3~~) Covers. Outdoor heated pools and outdoor ~~permanent~~ residential spas shall be provided with a vapor retardant cover, ~~a liquid cover~~ or other *approved* vapor retardant means.

Exception: Where more than 70 percent of the energy for heating, computed over an operating season, is from site-recovered energy such as from a heat pump or solar energy source, covers or other vapor retardant means shall not be required

Committee Reason: For the modification, the committee agreed with the testimony from the proponent of floor modification that heaters and time switches for pools and spas accessory to IRC-type buildings do not need to comply with the same, more stringent, requirements for commercial applications. For the overall proposal, the committee agreed with the proponent's reason statement.

Assembly Action:

None

Individual Consideration Agenda

This item is on the agenda for individual consideration because public comments were submitted.

Public Comment 1:

Jennifer Hatfield, J. Hatfield & Associates, PL, representing the Association of Pool & Spa Professionals requests Approval as Modified by this Public Comment.

Further modify the proposal as follows:

R403.9 (N1104.9)) Pools and permanent spa energy consumption (Mandatory). The energy consumption of pools and permanent residential spas shall be controlled by the requirements in Sections R403.9.1 through R403.9.3.

Exception: Heaters and time switches for swimming pools and permanent spas that are accessory to detached one- and two-family dwellings and townhouses 3 stories or less in height above ground plane and that are available only to the household and its guests shall be in accordance with APSP-15.

R403.9.3 (N1104.9.3) Covers. Outdoor heated pools and outdoor permanent residential spas shall be provided with a vapor retardant cover or other *approved* vapor retardant means.

Exception: Where more than 70 percent of the energy for heating, computed over an operating season, is from site-recovered energy such as from a heat pump or solar energy source, covers or other vapor retardant means shall not be required

R403.10 (N1103.10) Portable residential spas (Mandatory). The energy consumption of electric-powered portable residential spas shall be controlled by the requirements of APSP 14.

R403.11 (N1104.11) Residential pools and permanent residential spas. Residential swimming pools and permanent residential spas that are accessory to detached one- and two- family dwellings and townhouses 3 stories or less in height above grade plane and that are available only to the household and its guests shall be in accordance with APSP-15.

Commenter's Reason: This public comment simply clarifies what provisions apply to public versus residential pools as opposed to permanent spas or portable spas, also ensuring consistency between the respective codes.

Public Comment 2:

Edward R. Osann, Natural Resources Defense Council on behalf of self (eosann@nrdc.org) requests Approval as Modified by this Public Comment.

Further modify the proposal as follows:

R403.9.3 (N1104.9.3) Covers. ~~Outdoor~~ Heated pools and outdoor residential spas shall be provided with a vapor retardant cover or other *approved* vapor retardant means.

Exception: Where more than 70 percent of the energy for heating, computed over an operating season, is from site-recovered energy such as from a heat pump or solar energy source, covers or other vapor retardant means shall not be required

Commenter's Reason: Without explanation or justification, the proposal as submitted would weaken current code language by removing the requirement that a pool cover be provided for all heated pools, whether located indoors or out. There is important value provided by a cover for an indoor pool, including humidity management, which has important energy implications. The modification in this comment would restore the current requirement that new heated indoor pools be provided with a vapor retardant cover.

SP19-13, Part III

Final Action: AS AM AMPC____ D

SP26-13

305.4

Proposed Change as Submitted

Proponent: Jennifer Hatfield, J. Hatfield & Associates, PL, representing the Association of Pool & Spa Professionals (jhatfield@apsp.org)

Revise as follows:

305.4 Structure wall as a barrier. Where a wall of a dwelling or structure serves as part of the *barrier*, and where any doors and or operable windows in the wall have with a sill heights of less than 48 inches (1219 mm) above the indoor floor that and where any of those doors or windows provide direct access to the aquatic vessel through the wall, shall be equipped with one or more of the following shall be required:

1. The doors and operable windows having a sill height of less than 48 inches (1219 mm) above the indoor floor shall have an alarm that produces an audible warning when the door, or window or their screens or window, is are opened. The alarm shall be *listed* and *labeled* as a water hazard entrance alarm in accordance with UL 2017. In dwellings or structures not required to be Accessible units, Type A units or Type B units, alarm the deactivation switches shall be located 54 inches (1372 mm) or more above the threshold of the door. In dwellings or structures required to be Accessible units, Type A units or Type B units, alarm the deactivation switches shall be located not greater than 54 inches (1372 mm) and not less than 48 inches (1219 mm) above the threshold of the door.
2. A safety cover that is *listed* and *labeled* in accordance with ASTM F 1346 is provided for the aquatic vessel.
3. An *approved* means of protection, such as self-closing doors with self-latching devices is provided. Such means of protection shall provide that the a degree of protection afforded that is not less than the protection afforded by Items 1 or 2.

Reason: How the charging paragraph originally was written, it did not make sense that doors and windows would be equipped with a safety cover, the proposed language clarifies what was the original intention

Cost Impact: The code change proposal will not increase the cost of construction.

305.4-SP-HATFIELD.DOC

Committee Action Hearing Results

Committee Action:

Approved as Modified

Modify the proposal as follows:

305.4 Structure wall as a barrier. Where a wall of a dwelling or structure serves as part of the *barrier*, and where any doors or operable windows in the wall have sill heights of less than 48 inches (1219 mm) above the indoor floor and where any of those doors or windows provide direct access to the *aquatic vessel* through the wall, one of the following shall be required:

1. The doors and operable windows having a sill height of less than 48 inches (1219 mm) above the indoor floor shall have an alarm that produces an audible warning when the door, window or their screens are opened. The alarm shall be *listed* and *labeled* as a water hazard entrance alarm in accordance with UL 2017. In dwellings or structures not required to be Accessible units, Type A units or Type B units, alarm deactivation switches shall be located 54 inches (1372 mm) or more above the threshold of the door. In dwellings or structures required to be Accessible units, Type A units or Type B units, alarm deactivation switches shall be located not greater than 54 inches (1372 mm) and not less than 48 inches (1219 mm) above the threshold of the door.
2. A safety cover that is *listed* and *labeled* in accordance with ASTM F 1346 is provided-installed on for the aquatic vessel.
3. An *approved* means of protection, such as self-closing doors with self-latching devices is provided. Such means of protection shall provide a degree of protection that is not less than the protection afforded by Items 1 or 2.

Committee Reason: The reason for the modification is so the inspector can see that the cover fits properly at the time of inspection. The remainder of the proposal provides a necessary clarification that doors and windows do not require safety covers.

Assembly Action:

None

Individual Consideration Agenda

This item is on the agenda for individual consideration because a public comment was submitted.

Public Comment:

Carl Baldassarra, P.E., FSFPE, Chair, ICC Code Technology Committee (cbaldassarra@RJAGroup.com) and Jennifer Hatfield, J. Hatfield & Associates, PL, representing the Association of Pool & Spa Professionals (jhatfield@apsp.org) request Approval as Modified by this Public Comment

Further modify the proposal as follows:

305.4 Structure wall as a barrier. Where a wall of a dwelling or structure serves as part of the *barrier* and where any doors or operable windows in the wall have sill heights of less than 48 inches (1219 mm) above the indoor floor and where any of those doors or windows provide direct access to the *aquatic vessel* through the that wall, one of the following shall be required:

1. ~~The doors and~~ Operable windows having a sill height of less than 48 inches (1219 mm) above the indoor finished floor and doors shall have an alarm that produces an audible warning when the ~~door, window, door~~ or their screens are opened. The alarm shall be *listed* and *labeled* as a water hazard entrance alarm in accordance with UL 2017. In dwellings or structures not required to be Accessible units, Type A units or Type B units, the operable parts of the alarm deactivation switches shall be located 54 inches (1372 mm) or more above the ~~threshold of the door~~ finished floor. In dwellings or structures required to be Accessible units, Type A units or Type B units, the operable parts of the alarm deactivation switches shall be located not greater than 54 inches (1372 mm) and not less than 48 inches (1219 mm) above the ~~threshold of the door~~ finished floor.
2. A safety cover that is *listed* and *labeled* in accordance with ASTM F 1346 is installed for the aquatic vessel.
3. An *approved* means of protection, such as self-closing doors with self-latching devices is provided. Such means of protection shall provide a degree of protection that is not less than the protection afforded by Item 1 or 2.

Commenter's Reason: The original proposal added the window sill height requirements to Item 1, therefore it no longer needs to be in the main paragraph. This clarifies the intent and application – which was the intent of the original proposal.

The language in Item 1 uses qualifier for doors and windows without consideration of what may not apply to both elements. One of our concerns is that this language could cause a misunderstanding regarding allowable door threshold height; thus the reordering of windows and doors. This makes it clear that the 48 inch sill is only associated with the window. The threshold of the door does not provide a location to measure for the windows. IBC Section 1008.1.9.2 uses 'finished floor', which would be an appropriate reference point for doors and windows. The reach concern is to the operable parts on the device, not the entire device. This is especially relevant for the Accessible, Type A and Type B units.

While not included in this proposal, since it is outside of the scope of the change, the language regarding height limits within Accessible, Type A and Type B units should also be in Section 305.3.3 for gates. See IBC Sections 1008.1.9.2 and 3109.4.7 for gate and door criteria. All three sections should be coordinated next round to include gates, doors and windows.

This proposal is being co-sponsored by the ICC Code Technology Committee. The ICC Board established the ICC Code Technology Committee (CTC) as the venue to discuss contemporary code issues in a committee setting which provides the necessary time and flexibility to allow for full participation and input by any interested party. The code issues are assigned to the CTC by the ICC Board as "areas of study". Information on the CTC, including: meeting agendas; minutes; reports; resource documents; presentations; and all other materials developed in conjunction with the CTC effort can be downloaded from the following website: <http://www.iccsafe.org/cs/CTC/Pages/default.aspx>. Since its inception in April/2005, the CTC has held twenty five meetings - all open to the public.

SP26-13

Final Action:

AS

AM

AMPC _____

D

SP33-13

307.4, Table 307.4 (New), 502.1, Table 502.1

Proposed Change as Submitted

Proponent: Jennifer Hatfield, J. Hatfield & Associates, PL, representing the Association of Pool & Spa Professionals (jhatfield@apsp.org)

Revise as follows:

307.4 Materials and structural design. ~~The structural design of Aquatic vessels shall conform to one or more of the standards indicated in Table 307.4.~~ The structural design of aquatic vessels shall be in accordance with the International Building Code or International Residential Code, as applicable in accordance with Section 102.7.1 of this code.

**TABLE 307.4
RESERVOIRS AND SHELLS**

MATERIAL	STANDARD
Dry shotcrete	ACI 304.2, ACI 308, ACI 318, ACI 506.2
Fiberglass reinforced plastic	ANSI Z124.7
Plastic	ANSI Z124.7
Poured-in-Place Concrete	ACI 318
Stainless steel (type 316, 316L, 304, 304L)	ASTM A 240
Tile	ASC A108/A118/A136.1
Vinyl	ASTM D 1593
Wet Shotcrete	ACI 306, ACI 305, ACI 308, ACI 318, ACI 506.2

Delete without substitution as follows:

502.1 Reservoirs and shells. ~~Spa and exercise spa reservoirs shall conform to one or more of the standards listed in Table 502.1.~~

**TABLE 502.1
RESERVOIRS AND SHELLS**

MATERIAL	STANDARD
Dry Shotcrete	ACI 304.2, ACI 308, ACI 506.2
Fiberglass Reinforced Plastic	ANSI Z124.7
Plastic	ANSI Z124.7
Poured-in-Place Concrete	ACI 318
Stainless Steel (Type 316, 316L, 304, 304L)	ASTM A 240
Tile	ASC A108/A118/A136.1
Vinyl	ASTM D 1593
Wet Shotcrete	ACI 306, ACI 305, ACI 308, ACI 506.2

Reason: It appears this table and requirement provided for in Section 502.1 for public spas and exercise spas was not provided for when addressing all other aquatic vessels. Therefore appears to be a need to submit under Chapter 3 and eliminating the requirements within Chapter 5.

Cost Impact: The code change proposal will not increase the cost of construction.

307.4-SP-HATFIELD.DOC

Committee Action Hearing Results

Committee Action: **Disapproved**

Committee Reason: There are inconsistencies between what this table indicates as standards for the materials and what the IBC indicates the standards are for these materials.

Assembly Action: **None**

Individual Consideration Agenda

This item is on the agenda for individual consideration because a public comment was submitted.

Public Comment:

Jennifer Hatfield, J. Hatfield & Associates, PL, representing the Association of Pool & Spa Professionals requests Approval as Modified by this Public Comment

Modify the proposal as follows:

307.4 Materials and structural design. *Aquatic vessels* shall conform to one or more of the standards indicated in Table 307.4. The structural design of aquatic vessels shall be in accordance with the *International Building Code* or *International Residential Code*, as applicable in accordance with Section 102.7.1 of this code.

**TABLE 307.4
RESERVOIRS AND SHELLS**

MATERIAL	STANDARD
Dry shotcrete	ACI 304.2, ACI 308, ACI 318, ACI 506.2
Fiberglass reinforced plastic	ANSI Z124.7
Plastic	ANSI Z124.7
Poured-in-Place Concrete	ACI 318
Stainless steel (type 316, 316L, 304, 304L)	ASTM A 240
Tile	ASC A108/A118/A136.1
Vinyl	ASTM D 1593
Wet Shotcrete	ACI 306, ACI 305, ACI 308, ACI 318, ACI 506.2

**TABLE 502.1
RESERVOIRS AND SHELLS**

Wet Shotcrete	ACI 306, ACI 305, ACI 308, ACI 318, ACI 506.2
---------------	---

Commenter's Reason: This addresses the committee's reason for disapproval by removing the dry and wet shotcrete and poured in place concrete parts of Table 307.4, which are not necessary and if left in would make for inconsistencies, as they are already covered under the IBC and IRC.

The title for Table 502.1 is being shown again, even though it was struck out in the original proposal so that the last line in the table, "wet shotcrete", could be shown struck out. The error was discovered after the Report of Hearings so I included it in this public comment so that there wouldn't be any misunderstanding about what was intended.

SP33-13

Final Action: AS AM AMPC____ D

SP36-13

311.1, 312.1, 313.1, 315.1, 704.1 (New), 704.2 (New), 704.1, 704.2, 704.5 (New), 704.6 (New), 704.6.1 (New), 704.6.2 (New), 704.7 (New), 704.7.1 (New), 704.7.2 (New), 704.7.3 (New), 704.8 (New), 704.9 (New), 704.9.1 (New), 704.9.2 (New), 704.9.3 (New)

Proposed Change as Submitted

Proponent: Jennifer Hatfield, J. Hatfield & Associates, PL, representing the Association of Pool & Spa Professionals (jhatfield@apsp.org)

Revise as follows:

311.1 General. The provisions of this section apply to *circulation systems* for *aquatic vessels*.

Exceptions:

1. *Portable residential spas* and *portable residential exercise spas*.
2. Onground storable pools supplied by the pool manufacturer as a kit that includes circulation system equipment that is accordance with Section 704.

312.1 General. The provisions of this section apply to *filters* for all *aquatic vessels*.

Exceptions:

1. *Portable residential spas* and *portable residential exercise spas*.
2. Onground storable pools supplied by the pool manufacturer as a kit that includes a filter that is in accordance with Section 704.

313.1 General. The provisions of this section apply to pumps and motors for *aquatic vessels*.

Exceptions:

1. *Portable residential spas* and *portable residential exercise spas*.
2. Onground storable pools supplied by the pool manufacturer as a kit that includes a pump and motor that is in accordance with Section 704.

315.1 General. The provisions of this section apply to *skimmers* for *aquatic vessels*.

Exceptions:

1. *Portable residential spas* and *portable residential exercise spas*.
2. Onground storable pools supplied by the pool manufacturer as a kit that includes a skimming system that is in accordance with Section 704.

704.1 General. A circulation system consisting of pumps, hoses, tubing, piping, return inlets, suction outlets, filters and other related equipment that provides for the circulation of water throughout the pool shall be located so that such items cannot be used by young children as a means of access to the pool.

704.2 Installation and support. Circulation equipment shall be installed, mounted and supported in accordance with the manufacturer's instructions.

704.34 Draining the system. In climates subject to freezing, *circulation system* equipment shall be designed and fabricated to drain the pool water from the equipment and exposed piping, by removal of drain plugs and manipulating valves or by other methods in accordance with the manufacturer's instructions.

704.42 Turnover. A pump including a motor shall be provided for circulation of the pool water. Where circulation equipment is required by the manufacturer, The equipment shall be sized to provide a turnover of the pool water at least not less than once every 12 hours. The system shall be designed to provide the required *turnover rate* based on the manufacturer's specified maximum flow rate of the filter, with a clean media condition of the filter. The system flow shall not exceed the filter manufacturer's maximum filter flow rate.

704.5 Piping and fittings. The process piping of the circulation system, including but not limited to hoses, tubing, piping, and fittings, shall be made of non-toxic material and shall be capable of withstanding an internal pressure of not less than 1½ times the rated pressure of the pump. Piping on the suction side of the pump shall not collapse when flow into such piping is blocked.

704.6 Filters. Pressure-type filters shall have an automatic internal means or a manual external means to relieve accumulated air pressure inside the filter tank. Filter tanks composed of upper and lower tank lids that are held in place by a perimeter clamp shall have a perimeter clamp that provides for a slow and safe release of air pressure before the clamp disengages the lids.

704.6.1 Automatic internal air relief. Filter tanks incorporating an automatic internal air relief as the principal means of air release shall be designed with a means to provide for a slow and safe release of pressure.

704.6.2 Separation tank. A separation tank used in conjunction with a filter tank shall have a manual air release or the tank shall be designed to provide for a slow and safe release of pressure when the tank is opened.

704.7 Pumps. Pool pumps shall be tested and certified by a nationally recognized testing laboratory in accordance with an edition of UL 1081 that is the latest edition published by UL at the time of manufacture of the pump. The pump horsepower rating and that rating indicated on the label cannot exceed the brake horsepower of the motor.

704.7.1 Cleanable strainer. Where a pressure-type filter is installed, a cleanable strainer or screen that captures materials such as solids, debris, hair and lint shall be provided upstream of the circulation pump.

704.7.2 Accessible pumps and motors. Pumps and motors shall be accessible for inspection and service in accordance with the pump and motor manufacturer's instructions.

704.7.3 Pump shut-off valves. An accessible means of shut-off of the suction and discharge piping for the pump shall be provided for maintenance and removal of the pump.

704.8 Suction outlets and return inlets. Suction outlets and return inlets shall be provided and arranged to produce uniform circulation of water so that sanitizer residual is maintained throughout the pool. Where installed, submerged suction outlets shall conform to APSP 16.

704.9 Surface skimmer systems. The surface skimming system provided shall be designed and constructed to skim the pool surface when the water level is maintained between the minimum and maximum fill level of the pool.

704.9.1 Coverage when used as a sole outlet. Where surface skimmers are used as the only pool water outlet system, not less than one skimmer shall be provided for each 800 ft² (74.3 m²), or fraction thereof, of the water surface area.

704.9.2 Coverage when used in combination with other outlets. Where surface skimmers are not the only outlet for pool water, they shall be considered to cover only that fraction of the 800 ft² (74.3 m²).

704.9.3 Location and venting. Skimmers shall be equipped with a vent that serves as a vacuum break.

Reason: This change is consistent with APSP-4 that requires onground storable pools to follow different requirements than for all other pools.

Cost Impact: The code change proposal will not increase the cost of construction.

Analysis: Regarding Section 704.7, ICC CP#28, Code Development, requires a specific edition of a standard for reference to allow understanding and approval of the detailed requirements proposed for the 2015 edition of the ISPSC. Further, the language proposed will enable variations on the specifications required on different projects.

311.1-SP-HATFIELD.DOC

Committee Action Hearing Results

Committee Action:

Disapproved

Committee Reason: The proposal was disapproved because there were numerous modifications that were proposed which were making the proposal very confusing. The final reason for disapproval was that the term "suction outlet" was used in several locations and it was felt that the word "suction" should not be used with "outlet". Not all outlets are directly connected to the suction side of a pump.

Assembly Action:

None

Individual Consideration Agenda

This item is on the agenda for individual consideration because a public comment was submitted.

Public Comment:

Jennifer Hatfield, J. Hatfield & Associates, PL, representing the Association of Pool & Spa Professionals requests Approval as Modified by this Public Comment

Modify the proposal as follows:

311.1 General. The provisions of this section apply to *circulation systems for aquatic vessels*.

Exceptions:

1. *Portable residential spas* and portable *residential exercise spas*.
2. Onground storable pools supplied by the pool manufacturer as a kit that includes circulation system equipment that is in accordance with Section 704.

704.4 Turnover. A pump, including a motor, shall be provided for circulation of the pool water. The equipment shall be sized to provide a turnover of the pool water not less than once every 12 hours. The system shall be designed to provide the required *turnover rate* based on the manufacturer's specified maximum flow rate of the filter, with a clean media condition of the filter. The system flow shall not exceed the filter manufacturer's maximum filter flow rate.

704.7 Pumps. Pool pumps shall be tested and certified by a nationally recognized testing laboratory in accordance with an edition of UL 1081 that is the latest edition published by UL at the time of manufacture of the pump. The pump horsepower rating and that rating indicated on the label cannot exceed the brake horsepower of the motor.

704.8 Suction Outlets and return inlets. Suction Outlets or suction outlets, and return inlets shall be provided and arranged to produce uniform circulation of water so that sanitizer residual is maintained throughout the pool. Where installed, submerged suction outlets shall conform to APSP 16.

Commenter's Reason: This public comment addresses the committee's concern about using the term "suction" to describe "outlet". Not all outlets from a pool are suction outlets. For example, a pool can be designed for proper circulation with the inlet to the pool near the bottom of the pool and the outlet being a skimmer (a gravity outlet) at the pool water surface. Changing the terminology in Section 704.8 allows for such an arrangement.

This public comment also removes language in the first sentence of Section 704.7: “that is the latest edition published by UL at the time of manufacture of the pump”. The I-codes reference specific editions of standards because the code must refer to a specific document that becomes law, not some unknown moving target. Open-ended references to standards are not compatible with ICC format.

Another change in this public comment was to remove the second sentence of Section 704.7. Because APSP 15 (for energy efficiency of residential swimming pool systems) applies to onground storable pools (as required by Section 303.1) there is no need for this requirement in this chapter.

And finally, this public comment corrects a few typos in other proposed sections. The changes in this public comment along with the changes in the original proposal are necessary to ensure consistency with APSP-4, which provides specific requirements for onground storable pools.

SP36-13

Final Action: AS AM AMPC_____ D

SP40-13
315.2, 315.3, 315.4

Proposed Change as Submitted

Proponent: Jennifer Hatfield, J. Hatfield & Associates, PL, representing the Association of Pool & Spa Professionals (jhatfield@apsp.org)

Revise as follows:

315.2 Required. A surface skimming system shall be provided for public aquatic vessels and shall be listed and labeled in accordance with NSF 50. Either a surface skimming system or a perimeter overflow system shall be provided for permanent inground residential pools and permanent residential spas. Where installed, surface skimming systems shall be designed and constructed to create a skimming action on the pool water surface when the water level in the pool is to skim the surface when the water level is maintained within the operational parameters.

Exception: Class D public pools designed in accordance with Chapter 6.

315.2.1 Circulation systems. Public pool circulation systems shall be designed to process a minimum of 100 percent of the turnover rate through skimmers.

TABLE 315.3
SKIMMER SIZING TABLE

AQUATIC VESSEL	AREA PER SKIMMER (SQ. FT)
Public pool	400-500
Residential pool	800
Spa (all types)	150

For SI: 1 square foot = 0.09 m².

Reason: This proposal tries to address several aspects:

- Section 315.2.1 doesn't follow what is in APSP-5 and in NSF 50. But 315.2.1 IS found in APSP-1, so the proposed change limits it to public pools.
- Regarding the NSF 50 aspect, after noting that all the APSP standards appear to require surface skimming systems to comply with NSF 50, added that aspect in the first sentence, but used the language as written in other areas of the ISPSC when requiring compliance with NSF 50.
- Added *permanent residential spas* in first sentence b/c APSP-3 states: **11.2 Design and Construction:** Skimming devices shall be provided on all residential spas,..."
- Inserting "where installed" makes clear to the code official that, for example, the automatic surface skimmer isn't required necessarily, but where one is installed, it must follow certain specifications.
- See 12.3 in APSP 1, provides for 500 sq ft, so change in Table 315.2 makes the standard and what is in the ISPSC consistent

Cost Impact: The code change proposal will not increase the cost of construction.

315.2-SP-HATFIELD.DOC

Committee Action Hearing Results

Committee Action:

Disapproved

Committee Reason: Exception No. 2 is too confusing. Maintained illumination appears to involve maintenance requirements. The code cannot be concerned with maintenance functions.

Assembly Action:

None

Individual Consideration Agenda

This item is on the agenda for individual consideration because a public comment was submitted.

Public Comment:

Bob Eugene of UL LLC representing UL LLC request s Approval as Modified by this Public Comment

Modify the proposal as follows:

315.2 Required. A *surface skimming system* shall be provided for public aquatic vessels and shall be *listed* and *labeled* in accordance with NSF 50. Either a *surface skimming system* or a perimeter overflow system shall be provided for permanent in-ground *residential pools* and *permanent residential spas*. Where installed, *surface skimming systems* shall be designed and constructed to create a skimming action on the pool water surface when the water level in the pool is within operational parameters.

Exceptions:

1. Class D public pools designed in accordance with Chapter 6.
2. Skimmers that are an integral part of a spa that has been listed and labeled in accordance with UL1563 shall not be required to be listed and labeled in accordance with NSF 50.

(Portions of proposal not shown remain unchanged)

Commenter's Reason: UL 1563 includes provisions for skimmers. Listing and labeling spas to UL 1563 provides for the required entrapment protection. Similar language has been included in the committee action for SP34-13 and SP35-13.

SP40-13

Final Action: AS AM AMPC_____ D

SP42-13

202, 321.2, 321.2.1, 321.2.2, 321.2.3, 321.3, 321.4

Proposed Change as Submitted

Proponent: Jennifer Hatfield, J. Hatfield & Associates, PL, representing the Association of Pool & Spa Professionals (jhatfield@apsp.org)

Add new definition:

MAINTAINED ILLUMINATION. The value, in foot-candles or equivalent units, below which the average illuminance on a specified surface is not allowed to fall. The average illuminance value on the specified surface at the time when maintenance of the lighting system must be carried out.

Revise as follows:

321.2 Artificial lighting required. When a pool is open during periods of low natural illumination, artificial lighting shall be provided so that all areas of the pool, including the ~~main drains suction outlets on the bottom of the pool,~~ will be visible. Illumination shall be sufficient to enable a lifeguard or other persons standing on the deck or sitting on a lifeguard stand adjacent to the pool edge to determine if a pool user is lying on the bottom of the pool and if the pool water is transparent and free from cloudiness.

These two conditions shall be met when all suction outlets are visible from the edge of the deck at all times when artificial lighting is illuminated and when an 8 inch (152 mm) diameter black disk, placed at the bottom of the pool in the deepest point, is visible from the edge of the pool deck at all times when artificial lighting is illuminated.

321.2.1 Pool and deck illumination. ~~Overhead lighting, or underwater lighting or both shall be provided to illuminate the pool and adjacent deck areas. Such~~ The lighting shall be listed, and labeled. And The lighting shall be installed in accordance with NFPA 70, ~~or the International Residential Code, as applicable in accordance with Section 102.7.1.~~

321.2.2 Illumination intensity. For outdoor pools, ~~the a~~ a combination of overhead and underwater lighting shall provide maintained illumination not less than 10 horizontal ~~3~~ foot-candles at the pool water surface. For indoor pools, ~~the a~~ a combination of overhead and underwater lighting shall provide maintained illumination not less than 30 horizontal ~~of 10~~ foot-candles at the pool water surface. Deck area lighting for both indoor and outdoor pools shall provide maintained illumination not less than 10 horizontal foot-candles at the walking surface of the deck.

321.2.3 Underwater lighting. Underwater lighting shall provide not less than 8 lumens per square foot of pool water surface area.

Exceptions:

1. The requirement of this section shall not apply where the total wattage of incandescent underwater lighting is not less than $\frac{1}{2}$ watt/ft² (5.4 watts/m²) of pool water surface.
2. The requirement of this section shall not apply where overhead lighting provides not less than 15 foot-candles of *maintained illumination* at the pool water surface, the overhead lighting provides visibility, without glare, of all areas of the pool are visible without glare, and underwater lighting provides a *maintained illumination* at the pool water surface that is equal to or greater than the difference between the *maintained illumination* required by Section 321.2.2 and the *maintained illumination* provided at the pool water surface by the overhead lighting. Underwater lighting shall not be required where such difference is less than zero.

321.3 Emergency illumination. *Public pools* and public pool areas that operate during periods of low illumination shall be provided with emergency lighting that will automatically turn on to permit evacuation of the pool and securing of the area in the event of power failure. Emergency lighting facilities shall be arranged to provide initial illumination that is not less than 0.1 foot-candle measured at any point on the water surface and at any point on the walking surface of the deck, and not less than an average of 1 foot-candle. At the end of the emergency lighting time duration, the illumination level shall be not less than 0.06 foot-candle measured at any point on the water surface and at any point on the walking surface of the deck, and not less than an average of 0.6 foot-candle. A maximum-to-minimum illumination uniformity ratio of 40 to 1 shall not be exceeded. ~~The emergency lighting intensity shall be not less than 1 foot-candle at the water surface and the walking surface of the deck.~~

321.4 Residential pool and deck illumination. Where lighting is installed for, and in, *residential pools* and *permanent residential spas*, such lighting shall be installed in accordance with NFPA 70 or the *International Residential Code*, as applicable in accordance with Section 102.7.1.

Reason: The changes proposed are due to the following:

1. Deletes "main drain" to be consistent with definition now routinely used, which is "suction outlet." Further – can now DELETE the definition of main drain in Chapter 2 because this was the ONLY section in the ISPSC that utilized the word "Main Drain." See this proposal under Chapter 2 definitions.
2. Under 321.2.2 Illumination intensity, proposal changes the requirements to conform more to aspects of the Model Aquatic Health Code and IESNA RP-6-01 (Illuminating Engineering Society of North America), both of which include requirements for indoor and outdoor pools and decks (regardless of whether indoors or outdoors). This is a good approach for most general public pools.
3. Under 321.2.3 provides new language stemming from the APSP-1 revisions. It also incorporates a lumen-based standard made necessary by new low-power lighting technologies. Additionally, the existing wattage/sq ft requirement for incandescent underwater lights is maintained as an exception.
4. Under 321.3, made consistent with IBC Section 1006.3.1 Emergency illumination requirements.
5. Under 321.4, adding "lighting is" makes it clear as to what is being discussed. Adding "for, and in" makes it clear that coverage is for lighting in and out of the pool or spa.

Cost Impact: The code change proposal will not increase the cost of construction.

321.2-SP-HATFIELD.DOC

Committee Action Hearing Results

Committee Action:

Disapproved

Committee Reason: Exception No. 2 is too confusing. Maintained illumination appears to involve maintenance requirements. The code cannot be concerned with maintenance functions.

Assembly Action:

None

Individual Consideration Agenda

This item is on the agenda for individual consideration because a public comment was submitted.

Public Comment:

Jennifer Hatfield, J. Hatfield & Associates, PL, representing the Association of Pool & Spa Professionals requests Approval as Modified by this Public Comment

Modify the proposal as follows:

MAINTAINED ILLUMINATION. The value, in foot-candles or equivalent units, below which the average illuminance on a specified surface is not allowed to fall. ~~The average illuminance value on the specified surface at the time when maintenance of the lighting system must be carried out.~~ Maintained illumination equals the initial average illuminance on the specified surface with new lamps, multiplied by the light loss factor (LLF), to account for reduction in lamp intensity over time.

321.2 Artificial lighting required. When a pool is open during periods of low natural illumination, artificial lighting shall be provided so that all areas of the pool, including ~~the~~ all suction outlets on the bottom of the pool, will be visible. Illumination shall be sufficient

to enable a lifeguard or other persons standing on the deck or sitting on a lifeguard stand adjacent to the pool edge to determine if a pool user is lying on the bottom of the pool and if the pool water is transparent and free from cloudiness.

These two conditions shall be met when all suction outlets are visible from the edge of the deck at all times when artificial lighting is illuminated and when an 8 inch (152 mm) diameter black disk, placed at the bottom of the pool in the deepest point, is visible from the edge of the pool deck at all times when artificial lighting is illuminated.

321.2.1 Pool and deck illumination. Overhead lighting, underwater lighting or both shall be provided to illuminate the pool and adjacent deck areas. The lighting shall be *listed* and *labeled*. The lighting shall be installed in accordance with NFPA 70.

321.2.2 Illumination intensity. For outdoor pools, any combination of overhead and underwater lighting shall provide maintained illumination not less than 10 horizontal foot-candles (10 lumens per square foot) [108 lux] at the pool water surface. For indoor pools, any combination of overhead and underwater lighting shall provide maintained illumination not less than 30 horizontal foot-candles (30 lumens per square foot) [323 lux] at the pool water surface. Deck area lighting for both indoor and outdoor pools shall provide maintained illumination not less than 10 horizontal foot-candles (10 lumens per square foot) [108 lux] at the walking surface of the deck.

321.2.3 Underwater lighting. Underwater lighting shall provide not less than 8 horizontal foot-candles (8 lumens per square foot) [86 lux] of at the pool water surface area, or not less than a total wattage of ½ watt/ft² (5.4 watts/m²) of pool water surface for incandescent underwater lighting where the fixtures and lamps are rated in watts.

Exceptions:

1. ~~The requirement of this section shall not apply where the total wattage of incandescent underwater lighting is not less than ½ watt/ft² (5.4 watts/m²) of pool water surface.~~
2. The requirement of this section shall not apply where overhead lighting provides not less than 15 foot-candles (15 lumens per square foot) [161 lux] of *maintained illumination* at the pool water surface, the overhead lighting provides visibility, without glare, of all areas of the pool, and the requirements of Section 321.2.2 are met or exceeded and underwater lighting provides a *maintained illumination* at the pool water surface that is equal to or greater than the difference between the *maintained illumination* required by Section 321.2.2 and the *maintained illumination* provided at the pool water surface by the overhead lighting. Underwater lighting shall not be required where such difference is less than zero.

Commenter's Reason: The public comment addresses the committee reasoning for disapproval by clarifying what is required under Section 321.2.3 and it revises the definition of *maintained illumination* to clarify that this is not a maintenance requirement. *Maintained Illumination* is a standard design quantity utilized in the lighting industry and defined by the Illuminating Engineering Society of North America (IESNA) standards and guidelines to represent the minimum amount of illumination that is allowed to exist given that the intensity of the artificial lighting will naturally decrease over time. *It* refers to a level of lighting which is evaluated at the initial planning and design stage, and not to any maintenance requirement or methodology. Use of this term therefore brings ISPSC into harmony with the standard definitions and practices used in the industry and reflected in the IESNA Standards and documents that are utilized by architects, engineers, lighting manufacturers, and installers when they design and install lighting systems. The public comment also ensures that all sections use both foot-candles and lumens. It also changes "the" to "all" in reference to suction outlets in Section 321.2 to ensure 1) that it remains consistent with APSP-7 as referenced in this Code, which provides that suction outlets are optional and 2) that when suction outlets are used, all are visible.

SP42-13

Final Action: AS AM AMPC____ D

SP44-13

323.2.1

Proposed Change as Submitted

Proponent: Jennifer Hatfield, J. Hatfield & Associates, PL, representing the Association of Pool & Spa Professionals (jhatfield@apsp.org)

Revise as follows:

323.2.1 Height. Handrails shall be between 34 inches (864mm) and 38 inches (965 mm) above the ramp or step surface as measured at the nosing of the step or finished surface of the slope.

Exception: The requirements of this section shall not apply to residential aquatic vessels.

Reason: What is the justification for this height range requirement applying to both public and residential installations? The 34"-38" height is already a requirement for stair and ramp rails in the ADA Standards for Accessible Design for public facilities. Many of rails do not meet the height requirements. The handrail height requirement should be removed from the general requirements section and placed into the public swimming pools section or exempt out the residential vessels, as proposed here. For inground residential swimming pools, the range for the rail height can be broader, or not specified.

Cost Impact: The code change proposal will not increase the cost of construction.

323.2.1-SP-HATFIELD.DOC

Committee Action Hearing Results

Committee Action:

Disapproved

Committee Reason: The proposal was disapproved because the handrail height dimensions have been proven to be the optimum dimensions for safety. The same level of safety should be provided for residential pools where handrails are installed.

Assembly Action:

None

Individual Consideration Agenda

This item is on the agenda for individual consideration because a public comment was submitted.

Public Comment:

Jennifer Hatfield, J. Hatfield & Associates, PL, representing the Association of Pool & Spa Professionals requests Approval as Modified by this Public Comment

Modify the proposal as follows:

323.2.1 Height. The top of the gripping surface of handrails for public pools and public spas shall be between 34 inches (864mm) and to 38 inches (965 mm) above the ramp or step surface as measured at the nosing of the step or finished surface of the slope. The top of the gripping surface of handrails for residential pools and residential spas shall be 30 inches (762 mm) to 38 inches (965 mm) above the ramp or step surface as measured at the nosing of the step or finished surface of the slope.

Exception: The requirements of this section shall not apply to residential aquatic vessels.

Commenter's Reason: The proposal was disapproved because the committee believed the same level of safety should be provided for residential pools as in public pools where handrails are installed. However, the 34" – 38" height requirement is derived solely from ADA Accessibility guidelines which apply only to public facilities, and bears no relationship to safety. Prior to the implementation of the ADA, public facilities relied on OSHA height requirements for handrails, which are were 30"-36". The OSHA requirements are based on safety, where the ADA requirements are based on accessibility. Therefore, the 34"-38" height specification should not be a requirement for a residential installation. Rather than provide an exception, this public comment simply clarifies that the 34-38 inches applies to public pools and then allows the 30-36 inch dimension for residential application.

It is important to note that the standard handrails that are sold into the residential market do not meet the 34"-38" requirements and if the code does not clarify that this only applies to public pool and spa handrails, a large number of products will have to be revised with great expense (whereas the commercial handrail product lines have made the change to the federal ADA requirements). The industry has been selling these standard rails for years and is not aware of any reports on injuries or safety issues or complaints related to the height of the products. The ADA requirement of 34-38 inches should not be applied to the residential market and this proposal makes that clarification all the while still providing for the safety that the committee was concerned about in their disapproval.

SP44-13

Final Action: AS AM AMPC____ D

SP47-13
406.4 (New), 406.5 (New)

Proposed Change as Submitted

Proponent: Jennifer Hatfield, J. Hatfield & Associates, PL, representing the Association of Pool & Spa Professionals (jhatfield@apsp.org)

Add new text as follows:

406.4 Decks between pools and spas. Decks between pools, spas or any combination of pools and spas, shall have a width of not less than 6 feet (1829 mm).

406.5 Deck covering. Walking surfaces of decks within 4 feet (1219 mm) of a pool or spa that are not equivalent in the strength, durability and slip resistance of the surface of a concrete deck shall be prohibited. Wooden walking surfaces and carpeted walking surfaces shall not be placed within 4 feet (1219 mm) of a pool.

(Renumber subsequent sections)

Reason: These are requirements found in many state health codes and are considered construction; therefore should be included in the ISPSC.

Cost Impact: The code change proposal will not increase the cost of construction.

406.4 (NEW) -SP-HATFIELD.DOC

Committee Action Hearing Results

Committee Action:

Disapproved

Committee Reason: The slip resistance of the surface of a concrete deck is too vague. Concrete decks can have a variety of finishes, each having different slip resistances.

Assembly Action:

None

Individual Consideration Agenda

This item is on the agenda for individual consideration because a public comment was submitted.

Public Comment:

Jennifer Hatfield, J. Hatfield & Associates, PL, representing the Association of Pool & Spa Professionals requests Approval as Modified by this Public Comment

Modify the proposal as follows:

~~406.5 Deck covering.~~ Walking surfaces of decks within 4 feet (1219 mm) of a pool or spa ~~shall be slip resistant~~ that are not equivalent in the strength, durability and slip resistance of the surface of a concrete deck shall be prohibited. ~~Wooden walking surfaces and carpeted walking surfaces shall not be placed within 4 feet (1219 mm) of a pool.~~

Commenter's Reason: The proposal was disapproved because the slip resistance of the surface of a concrete deck was too vague. This public comment simplifies the proposal to require deck coverings to be slip resistant, which is then defined in the code.

SP47-13

Final Action: AS AM AMPC___ D

SP50-13

411.1

Proposed Change as Submitted

Proponent: Jennifer Hatfield, J. Hatfield & Associates, PL, representing the Association of Pool & Spa Professionals (jhatfield@apsp.org)

Revise as follows:

411.1 Entry and exit. Pools shall have ~~at least~~ not less than two means of entry and exit, that are located so as to serve both ends of a pool. Chair lifts that provide for pool entry and exit by persons with physical disabilities shall not be counted as a means of entry or exit that is required by this section.

Reason: This language is included in the APSP-1 revisions and with new ADA requirements now in effect it is good to make this clarification.

Cost Impact: The code change proposal will not increase the cost of construction.

411.1-SP-HATFIELD.DOC

Committee Action Hearing Results

Committee Action:

Approved as Modified

Modify the proposal as follows:

411.1 Entry and exit. Pools shall have not less than two means of entry and exit that are located so as to serve both ends of a pool. ~~Chair~~ Pool lifts that provide for pool entry and exit by persons with physical disabilities shall not be counted as a means of entry or exit that is required by this section.

Committee Reason: The reason for the modification is that "pool" lifts is the proper terminology, not chair lifts. The reason for approval of the overall change is that this provides a necessary clarification to the code so that lifts are not considered as the required means of exit and entry.

Assembly Action:

None

Individual Consideration Agenda

This item is on the agenda for individual consideration because a public comment was submitted.

Public Comment:

Carl Baldassarra, P.E., FSFPE, Chair, ICC Code Technology Committee (cbaldassarra@RJAGroup.com) and Jennifer Hatfield, J. Hatfield & Associates, PL, representing the Association of Pool & Spa Professionals (jhatfield@apsp.org) request Approval as Modified by this Public Comment.

Further modify the proposal as follows:

411.1 Entry and exit. Pools shall have not less than two means of entry and exit that are located so as to serve both ends of a pool. Pool lifts, transfer walls and transfer system that provide for pool entry and exit by persons with physical disabilities in accordance with Section 307.9 shall not be counted as a means of entry or exit ~~that is~~ required by this section.

Commenter's Reason: We wish to further modify what was already approved because there are other entry options provided for in ICC A117.1 (and ADA) for persons with disabilities. See the pictures below for graphics of the three types that would not work for general entry.

Section 307.9 references the IBC for accessibility, which in turn references the ICC A117.1 for technical criteria for these three types of entries.

This proposal is being co-sponsored by the ICC Code Technology Committee. The ICC Board established the ICC Code Technology Committee (CTC) as the venue to discuss contemporary code issues in a committee setting which provides the necessary time and flexibility to allow for full participation and input by any interested party. The code issues are assigned to the CTC by the ICC Board as "areas of study". Information on the CTC, including: meeting agendas; minutes; reports; resource documents; presentations; and all other materials developed in conjunction with the CTC effort can be downloaded from the following website: <http://www.iccsafe.org/cs/CTC/Pages/default.aspx>. Since its inception in April/2005, the CTC has held twenty five meetings - all open to the public.

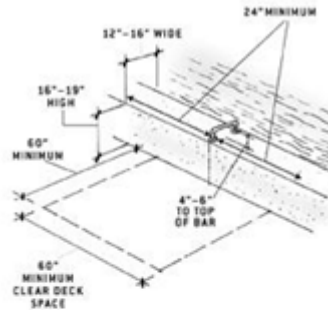

TRANSFER WALL WITH ONE GRAB BAR

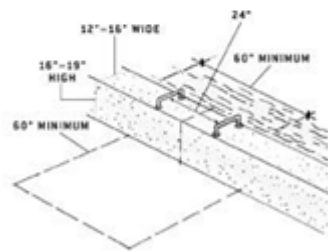

TRANSFER WALL WITH TWO GRAB BARS

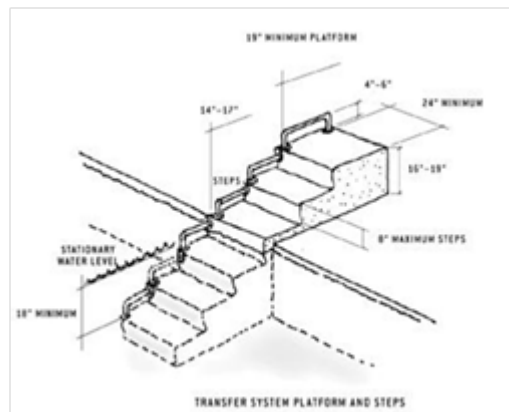

TRANSFER SYSTEM PLATFORM AND STEPS

SP50-13

Final Action:

AS

AM

AMPC_____

D

SP59-13
702.2.1, Chapter 11

Proposed Change as Submitted

Proponent: Jennifer Hatfield, J. Hatfield & Associates, PL, representing the Association of Pool & Spa Professionals (jhatfield@apsp.org)

Revise as follows:

702.2.1 Barrier required. Ladders in the pool shall have a physical barrier to prevent children from swimming through the riser openings or behind the ladder. Ladders made by ladder manufacturers that provide a certification statement that their ladder meets the acceptance criteria for the entrapment tests of APSP 4 shall be considered to be in compliance with this section.

Add standard to Chapter 11:

APSP

APSP 4-2012 Standard for Aboveground/Onground Residential Swimming Pools

Reason: The change follows what is in the 2012 APSP-4 revisions; all the code official will need to see is the certificate.

Cost Impact: The code change proposal will not increase the cost of construction

702.2.1-SP-HATFIELD.DOC

Committee Action Hearing Results

Committee Action:

Disapproved

Committee Reason: The committee disapproved this proposal because allowing the ladder manufacturer to provide the certification statement doesn't require that a third party verify that the ladder actually does meet the entrapment tests of APSP 4.

Assembly Action:

None

Individual Consideration Agenda

This item is on the agenda for individual consideration because a public comments were submitted.

Public Comment 1:

Jennifer Hatfield, J. Hatfield & Associates, PL, representing the Association of Pool & Spa Professionals requests Approval as Modified by Public Comment

Modify the proposal as follows:

702.2.1 Barrier required. Ladders in the pool shall have a physical barrier to prevent children from swimming through the riser openings or behind the ladder. ~~Ladders made by ladder manufacturers that provide a certification statement that their ladder meets the acceptance criteria for the entrapment tests of APSP 4 shall be considered to be in compliance with this section.~~

Exception: Barriers for the ladder shall not be required where the ladder manufacturer provides a test report by an *approved* third party testing agency certifying that the ladder complies with the ladder entrapment test requirements of APSP 4 or where the ladder is *listed* and *labeled* as complying with the requirements of APSP 4.

Commenter's Reason: This public comment is intended to maximize protection from ladder entrapment in all onground pool designs, including those for which a physical barrier is not practical. This issue was investigated at length by the ANSI/APSP-4 writing committee, resulting in the alternative compliance test. The test is conducted using a fully assembled ladder and pool wall,

and is based on recognized biomechanical principles including the ASTM F1148-09 Standard for consumer playground safety. It ensures that a bather cannot be entrapped between the ladder risers or the ladder and pool wall. The test checks the spaces between the rungs as well as the space between the ladder and the pool wall.

Testing would be performed by an approved third party testing agency and the manufacturer would demonstrate compliance with either: 1) a test report included in the installation instructions, 2) a tag attached to the ladder with a link to where the test report and/or listing can be downloaded by the inspector, or 3) a label affixed to the ladder itself. As the original proposal noted, this alternative is found in the 2012 edition of the ANSI/APSP-4 Standard and is being added to ensure consistency with the ISPSC and the ANSI/APSP standards.

Public Comment 2:

Matthew Whalen, Director of Risk Management, representing Intex Recreation Corp requests Approval as Modified by Public Comment

Modify the proposal as follows:

702.2.1 Barrier required. Ladders in the pool shall have a physical barrier to prevent children from swimming through the riser openings or behind the ladder. ~~Ladders made by ladder manufacturers that provide a certification statement that their ladder meets the acceptance criteria for the entrapment tests of APSP 4 shall be considered to be in compliance with this section.~~

Exception: Barriers for ladders shall not be required where the ladder manufacturer provides a certification statement that the ladder complies with the ladder entrapment test requirements of APSP 4.

Commenter's Reason: This public comment is intended to maximize protection from ladder entrapment in all onground pool designs, including those for which a physical barrier is not practical. This issue was investigated at length by the ANSI/APSP-4 writing committee, resulting in the alternative compliance test. The test is conducted using a fully assembled ladder and pool wall, and is based on recognized biomechanical principles including the ASTM F1148-09 Standard for consumer playground safety. It ensures that a bather cannot be entrapped between the ladder risers or the ladder and pool wall. The test checks the spaces between the rungs as well as the space between the ladder and the pool wall.

The public comment rewords the original proposal to clarify that the ladder entrapment test is an alternative to the physical barrier requirement found in 702.2.1, thereby providing consistency with the ANSI/APSP-4 Standard. Performance of the ladder entrapment test is readily within the capabilities of onground pool manufacturers, and therefore, as with virtually all other aspects of ANSI/APSP-4, this proposal recognizes self-testing and self-certification, which can be documented on the ladder or in contained product literature.

SP59-13

Final Action: AS AM AMPC____ D
