

INTERNATIONAL CODE COUNCIL 2018 CODE DEVELOPMENT CYCLE

2018 DISCUSSION GUIDE AND TECHNICAL UPDATES TO THE PUBLIC COMMENT AGENDA

INTERNATIONAL BUILDING CODE®

-FIRE SAFETY

(Includes Structural portions)

-GENERAL

(Includes Structural portions)

-MEANS OF EGRESS

INTERNATIONAL FIRE CODE®

INTERNATIONAL FUEL GAS CODE®

INTERNATIONAL MECHANICAL CODE®

INTERNATIONAL PLUMBING CODE®

INTERNATIONAL PRIVATE SEWAGE DISPOSAL CODE®

INTERNATIONAL PROPERTY MAINTENANCE CODE®

INTERNATIONAL RESIDENTIAL CODE®

--MECHANICAL

--PLUMBING

INTERNATIONAL SWIMMING POOL AND SPA CODE®

INTERNATIONAL WILDLAND-URBAN INTERFACE CODE®



October 24 – 31, 2018

GREATER RICHMOND CONVENTION CENTER

RICHMOND, VA

2018-2019 Code Development Cycle, Group A (2018) Discussion Guide and Updates to the 2018 *International Codes*

First Printing

Publication Date: October 2018

Copyright © 2018

by

International Code Council, Inc.

ALL RIGHTS RESERVED. This 2018-2019 Code Development Cycle, Group A (2018) Discussion Guide and Updates to the Public Comment Agenda to the 2018 *International Codes* is a copyrighted work owned by the International Code Council, Inc. ("ICC"). Without advance written permission from the ICC, no part of this book may be reproduced, distributed, or transmitted in any form or by any means, including, without limitations, electronic, optical or mechanical means (by way of example and not limitation, photocopying, or recording by or in an information storage retrieval system). For information on use rights and permissions, please contact: ICC Publications, 4051 Flossmoor Road, Country Club Hills IL, 60478. Phone 1-888-ICC-SAFE (422-7233).

Trademarks: "International Code Council," the "International Code Council" logo, "ICC," the "ICC" logo and other names and trademarks appearing in this book are registered trademarks of the International Code Council, Inc., and/or its licensors (as applicable), and may not be used without permission.

PRINTED IN THE U.S.A.

TABLE OF CONTENTS

Discussion Guide	1
IPMC	3
IBC – General	3
IBC – Fire Safety (includes IBC – Structural).....	5
IBC – Egress	7
IWUIC.....	8
IFC	9
ISPSC	11
IFGC.....	12
IMC.....	12
IRC – Mechanical (includes IRC – Building).....	13
IPSDC	14
IPC	14
IRC – Plumbing	16
Technical Updates to the Public Comment Agenda	17
IBC – General	19
IBC – Fire Safety.....	26
IBC – Structural (heard by IBC – Fire Safety).....	27
IFC.....	28
IFGC	30
IMC	31
IRC – Building (heard by IRC – Plumbing)	33
IPC.....	34

DISCUSSION GUIDE 2018 (GROUP A) ICC CODE DEVELOPMENT CYCLE PUBLIC COMMENT AGENDA DISCUSSION GUIDE

The purpose of this guide is to assist the efficient discussion of the individual agenda items by providing an overview of the committee actions, assembly actions (if any) and the submitted Public Comments. The agenda items are listed in the same order as the published Tentative Hearing Order on page xxxiii of the 2018 Public Comment Agenda document.

See page xxv of the 2018 Public Comment Agenda document (Section 7.5 of CP#28-05). Section 7.5.9.5 requires that the Code Development Committee Action be the initial motion.

Whenever a motion under consideration is for Approval as Submitted or Approval as Modified, a subsequent motion and second for a modification published in the Public Comment Agenda may be made (see Section 6.4.4). Each subsequent motion for modification, if any, shall be individually discussed and voted before returning to the main motion. When the initial motion is for Disapproval, that motion must be voted upon before any other motions are entered. This is reflected in the column under “Allowable Subsequent Motions per Section 7.5.9.6 (CP#28).

Excerpts from CP #28:

7.5.9.5 Initial Motion: The code development committee action shall be the initial motion considered.

7.5.9.6 Motions for Modifications: Whenever a motion under consideration is for Approval as Submitted or Approval as Modified, a subsequent motion and second for a modification published in the Public Comment Agenda may be made (see Section 6.4.4). Each subsequent motion for modification, if any, shall be individually discussed and voted before returning to the main motion. A two-thirds majority based on the number of votes cast by eligible voters shall be required for a successful motion on all modifications.

7.5.9.7 Voting: After dispensing with all motions for modifications, if any, and upon completion of discussion on the main motion, the Moderator shall then ask for the vote on the main motion. The vote on the main motion shall be taken electronically with the vote recorded and each vote assigned to the eligible voting member. In the event the electronic voting system is determined not to be used by ICC, a hand/standing count will be taken by the Moderator. If the motion fails to receive the majority required in Section 7.6, the Moderator shall ask for a new motion.

7.5.9.8 Subsequent Motion: If the initial motion is unsuccessful, a motion for either Approval as Submitted or Approval as Modified by one or more published modifications is in order. A motion for Disapproval is not in order. The vote on the main motion shall be taken electronically with the vote recorded and each vote assigned to the eligible voting member. In the event the electronic voting system is determined not to be used by ICC, a hand/standing count will be taken by the Moderator. If a successful vote is not achieved, Section 7.5.9.9 shall apply.

7.5.9.9 Failure to Achieve Majority Vote at the Public Comment Hearing. In the event that a code change proposal does not receive any of the required majorities in Section 7.6, the results of the Public Comment Hearing for the code change proposal in question shall be Disapproval. The vote count that will be reported as the Public Comment Hearing result will be the vote count on the main motion in accordance with Section 7.5.9.7.

7.5.9.10 Public Comment Hearing Results: The result and vote count on each code change proposal considered at the Public Comment Hearing shall be announced at the hearing. In the event the electronic voting system is not utilized and a hand/standing count is taken in accordance with Sections 7.5.9.7 and 7.5.9.8, the vote count will not be announced if an individual standing vote count is not taken. The results shall be posted and included in the Online Governmental Consensus Ballot (see Section 8.2).

7.6 Majorities for Final Action: The required voting majority for code change proposals individually considered shall be based on the number of votes cast of eligible voters at the Public Comment Hearing shall be in accordance with the following table:

Committee Action	Desired Final Action		
	AS	AM/AMPC	D
AS	Simple Majority	2/3 Majority	Simple Majority
AM	2/3 Majority	Simple Majority to sustain the Committee Action or; 2/3 Majority on each additional modification and 2/3 Majority on entire code change proposal for AMPC	Simple Majority
D	2/3 Majority	2/3 Majority	Simple Majority

Note 1: This public comment has been submitted by the ICC Code Correlation Committee. The public comment does not request an action and is intended to identify a possible code correlation issue. See the individual public comment for more information.

Note 2: This public comment has been submitted by CP28 Administration. The public comment does not request an action and is intended to identify a procedural issue (CP28 Section 3.6.3.1.1). See the individual public comment for more information.

PROPOSED CHANGE	COMMITTEE HEARING ACTION	ALLOWABLE SUBSEQUENT MOTIONS PER SECTION 7.5.8.6 (CP# 28)	PUBLIC COMMENTS		FINAL ACTION
			DESIRED ACTION	PUBLIC COMMENT NUMBER	
INTERNATIONAL PROPERTY MAINTENANCE CODE					
G130-18 Part II	D	<i>None</i>	AMPC	1	
PM8-18 Part I	D	<i>None</i>	AMPC	1	
			AS	2	
PM8-18 Part II	D	<i>None</i>	AS	1	
PM9-18	D	<i>None</i>	AS	1, 2	
PM10-18	AM	<i>None</i>	D	1	
INTERNATIONAL BUILDING CODE – GENERAL					
G15-18 Part I	D	<i>None</i>	AS	1	
G15-18 Part II	D	<i>None</i>	AS	1	
G21-18	AS	<i>AMPC</i>	AMPC	1, 2	
P13-18	D	<i>None</i>	AMPC	1	
G1-18	D	<i>None</i>	AMPC	1	
G32-18	AM	<i>AMPC</i>	AMPC	1	
G37-18	D	<i>None</i>	AS	1	
G39-18	D	<i>None</i>	AMPC	1	
G54-18	D	<i>None</i>	AS	1	
G72-18	D	<i>None</i>	AS	1	
G76-18	D	<i>None</i>	AS	1	
G86-18	D	<i>None</i>	AMPC	1	
G87-18	D	<i>None</i>	AMPC	1	
G88-18	D	<i>None</i>	AMPC	1	
G90-18	AS	<i>AMPC</i>	AMPC	1	
G93-18	D	<i>None</i>	AMPC	1	
G94-18	D	<i>None</i>	AMPC	1	
G95-18	AS	<i>None</i>	D	1	
G97-18	AS	<i>None</i>	D	1	

PROPOSED CHANGE	COMMITTEE HEARING ACTION	ALLOWABLE SUBSEQUENT MOTIONS PER SECTION 7.5.8.6 (CP# 28)	PUBLIC COMMENTS		FINAL ACTION
			DESIRED ACTION	PUBLIC COMMENT NUMBER	
G108-18	AM	AMPC	AMPC	1, 2, 3	
			AS	4	
			AM	5	
			D	6 through 102 & 104	
			–	103 (See Note 1)	
G89-18	AM	AMPC	AMPC	1	
			–	2 (See Note 1)	
FS81-18	AM	None	D	1, 2	
			–	3 (See Note 1)	
FS5-18	AS	None	D	1	
			–	2 (See Note 1)	
FS6-18	AS	AMPC	AMPC	1	
			–	2 (See Note 1)	
FS73-18	AS	None	–	1 (See Note 1)	
G28-18	AS	None	–	1 (See Note 1)	
F266-18	AM	AMPC	AMPC	1	
			–	2 (See Note 1)	
G75-18	AM	AMPC	AMPC	1, 2, 3	
			AM	4, 5	
			D	6 through 14	
			–	15 (See Note 1)	
G80-18	AS	AMPC	AMPC	1, 2, 3	
			AS	4, 5	
			D	6 through 16	
			–	17 (See Note 1)	
G84-18	AS	AMPC	AMPC	1, 2, 3	
			AS	4, 5	
			D	6 through 11	
			–	12 (See Note 1)	
G113-18	D	None	AMPC	1	
G121-18	D	None	AS	1	
G122-18	AS	None	D	1	
G124-18	D	None	AMPC	1, 2	
G125-18	D	None	AMPC	1	

PROPOSED CHANGE	COMMITTEE HEARING ACTION	ALLOWABLE SUBSEQUENT MOTIONS PER SECTION 7.5.8.6 (CP# 28)	PUBLIC COMMENTS		FINAL ACTION
			DESIRED ACTION	PUBLIC COMMENT NUMBER	
G133-18	D	None	AMPC	1	
G135-18	D	None	AMPC	1	
G136-18	AS	AMPC	AMPC	1	
G137-18	D	None	AS	1	
G139-18	D	None	AMPC	1	
			D	2	
G140-18	D	None	AMPC	1	
G149-18	D	None	AMPC	1	
			AS	2	
G151-18	AM	AMPC	AMPC	1, 2	

INTERNATIONAL BUILDING CODE – FIRE SAFETY

FS3-18	AS	AMPC	AMPC	1	
FS8-18	AM	AMPC	AMPC	1	
FS10-18	D	None	AMPC	1	
FS15-18	D	None	AMPC	1	
FS19-18	D	None	AMPC	1	
FS20-18	D	None	AMPC	1, 2	
FS21-18	D	None	AMPC	1, 2	
FS22-18	AS	AMPC	AMPC	1	
FS23-18	D	None	AMPC	1	
FS24-18	AS	AMPC	AMPC	1	
FS29-18	D	None	AMPC	1	
FS31-18	D	None	AMPC	1, 2	
FS34-18	D	None	AS	1	
FS36-18	D	None	AMPC	1	
FS39-18	AS	AMPC	AMPC	1	
FS46-18	D	None	AS	1	
FS48-18	AS	None	D	1	
FS49-18	D	None	AMPC	1	
FS53-18	AM	AMPC	AMPC	1	
FS54-18	D	None	AMPC	1	

PROPOSED CHANGE	COMMITTEE HEARING ACTION	ALLOWABLE SUBSEQUENT MOTIONS PER SECTION 7.5.8.6 (CP# 28)	PUBLIC COMMENTS		FINAL ACTION
			DESIRED ACTION	PUBLIC COMMENT NUMBER	
FS56-18	D	None	AMPC	1	
			AS	2	
FS60-18	AS	AMPC	AMPC	1	
			D	2	
G34-18	AM	None	D	1	
M72-18	AS	AMPC	AMPC	1	
FS74-18	D	None	AMPC	1	
			D	2	
FS78-18	D	None	AMPC	1	
			AS	2	
FS82-18	D	None	AMPC	1	
FS83-18	D	None	AS	1	
FS85-18	D	None	AMPC	1	
FS91-18	D	None	AMPC	1	
FS93-18	D	None	AMPC	1, 2	
FS94-18	D	None	AS	1	
FS95-18	D	None	AMPC	1	
FS96-18	D	None	AMPC	1	
			D	2	
FS99-18	D	None	AMPC	1, 2	
			D	3	
FS103-18	D	None	AMPC	1	
FS104-18	D	None	AMPC	1	
FS108-18	AM	None	Withdrawn by Proponent		
FS110-18	D	None	AMPC	1	
FS111-18	D	None	AS	1	
FS149-18	D	None	AMPC	1	
			D	2	
S9-18	AS	None	D	1	
S17-18	D	None	AS	1	
S18-18	D	None	AS	1	
S20-18	D	None	AMPC	1	
S21-18	AS	None	D	1	
FS155-18	AS	None	–	1 (See Note 2)	

PROPOSED CHANGE	COMMITTEE HEARING ACTION	ALLOWABLE SUBSEQUENT MOTIONS PER SECTION 7.5.8.6 (CP# 28)	PUBLIC COMMENTS		FINAL ACTION
			DESIRED ACTION	PUBLIC COMMENT NUMBER	
S6-18	D	None	AS	1	
S7-18	D	None	AMPC	1	
			D	2, 3	
INTERNATIONAL BUILDING CODE – EGRESS					
E1-18	D	None	AMPC	1	
E2-18	D	None	AMPC	1	
E13-18	AS	AMPC	AMPC	1	
E15-18 Part 1	AS	AMPC	AMPC	1, 2	
E18-18	AM	AMPC	AMPC	1	
			AS	2, 3	
G35-18	AS	AMPC	AMPC	1	
E96-18	D	None	AS	1	
E20-18	D	None	AMPC	1	
E21-18	D	None	AS	1	
E22-18	D	None	AMPC	1	
E24-18	AS	None	D	1	
E30-18	AS	AMPC	AMPC	1, 2, 3, 4	
E31-18	D	None	AMPC	1	
E32-18	D	None	AMPC	1	
E33-18	D	None	AS	1	
E38-18	AM	AMPC	AMPC	1, 2	
E39-18	AS	None	D	1	
E40-18	D	None	AMPC	1	
E41-18	AS	None	D	1	
E42-18	AS	None	D	1	
E44-18	AS	AMPC	AMPC	1	
E49-18	D	None	AMPC	1	
			D	2	
E51-18	D	None	AMPC	1	
			AS	2, 3	
E52-18	AS	AMPC	AMPC	1	
			D	2	

PROPOSED CHANGE	COMMITTEE HEARING ACTION	ALLOWABLE SUBSEQUENT MOTIONS PER SECTION 7.5.8.6 (CP# 28)	PUBLIC COMMENTS		FINAL ACTION
			DESIRED ACTION	PUBLIC COMMENT NUMBER	
E53-18	D	<i>None</i>	AMPC	1	
E58-18	D	<i>None</i>	AMPC	1, 2	
E60-18	D	<i>None</i>	AS	1	
E62-18	D	<i>None</i>	AS	1	
E64-18	AM	<i>AMPC</i>	AMPC	1	
E67-18	D	<i>None</i>	AMPC	1	
E69-18	D	<i>None</i>	AMPC	1	
E70-18	D	<i>None</i>	AMPC	1, 2	
E71-18	D	<i>None</i>	AMPC	1	
E76-18	D	<i>None</i>	AMPC	1	
E79-18	D	<i>None</i>	AS	1	
E81-18	D	<i>None</i>	AMPC	1	
			AS	2, 3, 4, 5	
			D	6, 7	
E82-18	D	<i>None</i>	AMPC	1	
			A	2, 3, 4, 5, 6	
			D	7, 8	
E86-18	AM	<i>AMPC</i>	AMPC	1	
E90-18	D	<i>None</i>	AS	1	
G43-18	AS	<i>AMPC</i>	AMPC	1	
E92-18	AS	<i>AMPC</i>	AMPC	1	
E106-18	D	<i>None</i>	AMPC	1, 2	
E107-18	AM	<i>AMPC</i>	AMPC	1	
E108-18	D	<i>None</i>	AMPC	1	
E109-18	D	<i>None</i>	AS	1	
E115-18	AS	<i>AMPC</i>	AMPC	1, 2, 3	
E117-18	D	<i>None</i>	AMPC	1	
E126-18	D	<i>None</i>	AS	1	
INTERNATIONAL WILDLAND URBAN INTERFACE CODE					
WUIC3-18	D	<i>None</i>	AMPC	1, 2	
WUIC4-18	D	<i>None</i>	AS	1	
WUIC5-18	D	<i>None</i>	AMPC	1	

PROPOSED CHANGE	COMMITTEE HEARING ACTION	ALLOWABLE SUBSEQUENT MOTIONS PER SECTION 7.5.8.6 (CP# 28)	PUBLIC COMMENTS		FINAL ACTION
			DESIRED ACTION	PUBLIC COMMENT NUMBER	
INTERNATIONAL FIRE CODE					
F8-18	D	None	AMPC	1	
F13-18	D	None	AMPC	1	
F17-18	D	None	AS	1	
F18-18	D	None	AMPC	1, 2	
			D	3	
F21-18	D	None	AMPC	1	
F92-18 Part I	D	None	AMPC	1	
F92-18 Part II	D	None	AMPC	1	
F22-18	AS	AMPC	AMPC	1	
F23-18	D	None	AMPC	1	
F26-18	AM	AMPC	AMPC	1	
F28-18	D	None	AMPC	1	
F37-18	D	None	AS	1	
F38-18	D	None	AS	1	
F43-18	D	None	AS	1	
F47-18	D	None	AMPC	1	
F49-18	D	None	AMPC	1	
F63-18	AM	AMPC	AMPC	1	
F64-18	AS	AMPC	AMPC	1	
F65-18	AM	AMPC	AMPC	1, 2	
F67-18	D	None	AMPC	1	
G91-18	D	None	AS	1	
F69-18	D	None	AS	1	
F76-18	AS	None	D	1	
			–	2 (See Note 2)	
F78-18	AS	None	D	1	
			–	2 (See Note 2)	
F79-18 Part I	D	None	AMPC	1	
F79-18 Part II	D	None	AMPC	1	
F81-18	D	None	AMPC	1	
F84-18	D	None	AMPC	1	

PROPOSED CHANGE	COMMITTEE HEARING ACTION	ALLOWABLE SUBSEQUENT MOTIONS PER SECTION 7.5.8.6 (CP# 28)	PUBLIC COMMENTS		FINAL ACTION
			DESIRED ACTION	PUBLIC COMMENT NUMBER	
F85-18	D	<i>None</i>	AS	1	
F86-18	D	<i>None</i>	AS	1	
F87-18	D	<i>None</i>	AMPC	1	
F91-18	D	<i>None</i>	AMPC	1	
F93-18	D	<i>None</i>	AMPC	1	
F95-18	D	<i>None</i>	AMPC	1	
F100-18	AS	<i>AMPC</i>	AMPC	1	
F4-18 Part I	AS	<i>None</i>	D	1	
F4-18 Part II	AS	<i>None</i>	D	1	
F106-18	AS	<i>AMPC</i>	AMPC	1	
			D	2	
F110-18	AM	<i>None</i>	D	1, 2	
F117-18	AS	<i>AMPC</i>	AMPC	1	
			AS	2	
			D	3	
F126-18	AS	<i>AMPC</i>	AMPC	1	
F128-18	D	<i>None</i>	AMPC	1	
F132-18	D	<i>None</i>	AMPC	1, 2, 3	
F138-18	D	<i>None</i>	AMPC	1	
F144-18	AS	<i>None</i>	D	1	
F149-18	AM	<i>AMPC</i>	AMPC	1	
F152-18	D	<i>None</i>	AMPC	1	
F153-18	D	<i>None</i>	AMPC	1	
F158-18	D	<i>None</i>	AMPC	1	
F169-18	D	<i>None</i>	AMPC	1	
F173-18	D	<i>None</i>	AS	1	
F174-18	AS	<i>None</i>	D	1	
F180-18	D	<i>None</i>	AMPC	1	
F182-18	AS	<i>AMPC</i>	AMPC	1, 2, 3, 4	
			D	5	
F185-18	D	<i>None</i>	AMPC	1	
F193-18	D	<i>None</i>	AMPC	1	
F199-18	D	<i>None</i>	AMPC	1	
F203-18	AM	<i>AMPC</i>	AMPC	1 through 17	

PROPOSED CHANGE	COMMITTEE HEARING ACTION	ALLOWABLE SUBSEQUENT MOTIONS PER SECTION 7.5.8.6 (CP# 28)	PUBLIC COMMENTS		FINAL ACTION
			DESIRED ACTION	PUBLIC COMMENT NUMBER	
			AS	18	
			-	19 (See Note 2)	
F209-18	D	<i>None</i>	AMPC	1	
F212-18	AM	<i>AMPC</i>	AMPC	1, 2, 3	
			D	4, 5	
F226-18	D	<i>None</i>	AMPC	1	
F229-18	D	<i>None</i>	AS	1	
F243-18	AM	<i>AMPC</i>	AMPC	1, 2, 3	
F245-18	D	<i>None</i>	AMPC	1	
F254-18	AM	<i>AMPC</i>	AMPC	1	
F262-18 Part I	D	<i>None</i>	AMPC	1	
F263-18	AM	<i>AMPC</i>	AMPC	1, 2	
F264-18	AS	<i>AMPC</i>	AMPC	1, 2, 3	
			AS	4	
F267-18 Part I	D	<i>None</i>	AS	1	
F267-18 Part II	D	<i>None</i>	AS	1	
F270-18	D	<i>None</i>	AS	1	
F276-18	AS	<i>None</i>	D	1, 2, 3, 4	
F277-18	D	<i>None</i>	AMPC	1	
F303-18	D	<i>None</i>	AMPC	1	
F300-18	AM	<i>None</i>	D	1	
F304-18	AS	<i>None</i>	Public Comment Withdrawn		
F314-18	D	<i>None</i>	AMPC	1	
F316-18	D	<i>None</i>	AMPC	1, 2	
F328-18	D	<i>None</i>	AS	1	
INTERNATIONAL SWIMMING POOL AND SPA CODE					
P1-18 Part V	AS	<i>AMPC</i>	AMPC	1	
SP1-18	AS	<i>AMPC</i>	AMPC	1	
SP5-18	AS	<i>None</i>	D	1	
SP8-18	AS	<i>AMPC</i>	AMPC	1	
SP23-18	AS	<i>AMPC</i>	AMPC	1, 2	
SP39-18	AM	<i>None</i>	AS	1	
SP40-18	AM	<i>None</i>	D	1 (Assembly Action)	
SP43-18	D	<i>None</i>	AMPC	1	

PROPOSED CHANGE	COMMITTEE HEARING ACTION	ALLOWABLE SUBSEQUENT MOTIONS PER SECTION 7.5.8.6 (CP# 28)	PUBLIC COMMENTS		FINAL ACTION
			DESIRED ACTION	PUBLIC COMMENT NUMBER	
INTERNATIONAL FUEL GAS CODE					
FG1-18	AS	AMPC	AMPC	1	
FG9-18	D	None	AS	1	
FG10-18	AS	None	AS	1	
			D	2, 3 (Assembly Action)	
FG14-18	AM	None	AS	1 (Assembly Action)	
			AM	2	
FG15-18	AS	None	AS	1	
			D	2 (Assembly Action)	
P1-18 Part IV	AS	AMPC	AMPC	1	
INTERNATIONAL MECHANICAL CODE					
P1-18 Part III	D	None	AMPC	1	
M3-18	D	None	AMPC	1	
M4-18	AS	AMPC	AMPC	1	
M6-18	D	None	AS	1	
M13-18	D	None	AMPC	1	
M20-18	AS	AMPC	AMPC	1	
			D	2	
M21-18	D	None	AMPC	1	
M23-18	D	None	AMPC	1, 2	
M25-18	AS	None	D	1	
M27-18	D	None	AMPC	1, 2	
M32-18	D	None	AMPC	1, 2	
M33-18	AS	None	D	1	
M34-18	AS	None	D	1	
M40-18	D	None	AMPC	1, 2	
M50-18	D	None	AMPC	1, 2	
M51-18	D	None	AS	1	
M62-18	AS	AMPC	AMPC	1	
M64-18	AS	None	D	1	

PROPOSED CHANGE	COMMITTEE HEARING ACTION	ALLOWABLE SUBSEQUENT MOTIONS PER SECTION 7.5.8.6 (CP# 28)	PUBLIC COMMENTS		FINAL ACTION
			DESIRED ACTION	PUBLIC COMMENT NUMBER	
M67-18	D	None	AMPC	1	
M70-18	D	None	AS	1, 2	
M71-18	AM	AMPC	AMPC	1	
M73-18	AS	None	D	1, 2, 3	
M74-18	AS	AMPC	AMPC	1	
M78-18 Part I	D	None	AS	1	
M78-18 Part II	D	None	AS	1	
M81-18	AS	AMPC	AMPC	1	
M88-18	D	None	AMPC	1	
M93-18	AS	AMPC	AMPC	1	
M95-18	AM	AMPC	AMPC	1	
M96-18	D	None	AMPC	1	
M97-18	D	None	AS	1, 2	
M98-18	D	None	AMPC	1	
			AS	2	
M99-18	AS	AMPC	AMPC	1	
			AS	2	
			D	3	
M102-18	AS	None	D	1, 2	
M112-18	D	None	AS	1	
M120-18	AM	None	Public Comment Withdrawn		

INTERNATIONAL RESIDENTIAL CODE – MECHANICAL

RB5-18	AS	AMPC	AMPC	1	
			D	2	
RM3-18	D	None	AS	1	
RM5-18	D	None	AMPC	1	
RM7-18	D	None	AS	1	
RM9-18	AS	AMPC	AMPC	1	
RM12-18	D	None	AMPC	1	
RM17-18	D	None	AS	1	
RM19-18	D	None	AMPC	1, 2	
RM22-18	D	None	AMPC	1	

PROPOSED CHANGE	COMMITTEE HEARING ACTION	ALLOWABLE SUBSEQUENT MOTIONS PER SECTION 7.5.8.6 (CP# 28)	PUBLIC COMMENTS		FINAL ACTION
			DESIRED ACTION	PUBLIC COMMENT NUMBER	
RM25-18	D	<i>None</i>	AS	1	
RM27-18	D	<i>None</i>	AS	1	
RM31-18	D	<i>None</i>	AMPC	1	
RM39-18	D	<i>None</i>	AS	1	
M119-18 Part II	AS	<i>None</i>	D	1 (Assembly Action)	

INTERNATIONAL PRIVATE SEWAGE DISPOSAL CODE

PSD1-18	D	<i>None</i>	AMPC	1	
PSD3-18	D	<i>None</i>	AMPC	1	
P1-18 Part VI	D	<i>None</i>	AMPC	1	

INTERNATIONAL PLUMBING CODE

P14-18	AS	AMPC	AMPC	1	
			D	2, 3	
P15-18	AM	AMPC	AMPC	1, 2, 3	
			AM	4	
			D	5, 6	
P17-18	D	<i>None</i>	AMPC	1, 2, 3	
			D	4	
P22-18 Part I	AS	AMPC	AMPC	1	
P22-18 Part II	D	<i>None</i>	AMPC	1, 2	
P23-18	D	<i>None</i>	AS	1	
P24-18	AM	AMPC	AMPC	1	
P25-18	AS	<i>None</i>	D	1	
P27-18	D	<i>None</i>	AMPC	1	
P29-18	AS	<i>None</i>	D	1 (Assembly Action)	
P35-18	D	<i>None</i>	AS	1, 2	
P38-18 Part I	AS	AMPC	AMPC	1	
P42-18	AS	<i>None</i>	–	1 (See Note 2)	
P45-18 Part I	D	<i>None</i>	AS	1	
P45-18 Part II	D	<i>None</i>	AS	1	
P48-18 Part I	AS	<i>None</i>	–	1 (See Note 2)	

PROPOSED CHANGE	COMMITTEE HEARING ACTION	ALLOWABLE SUBSEQUENT MOTIONS PER SECTION 7.5.8.6 (CP# 28)	PUBLIC COMMENTS		FINAL ACTION
			DESIRED ACTION	PUBLIC COMMENT NUMBER	
P50-18 Part I	D	None	AMPC	1	
P50-18 Part II	D	None	AMPC	1	
P51-18	AM	AMPC	AMPC	1	
			–	2 (See Note 2)	
P53-18	D	None	AMPC	1	
P60-18	D	None	AS	1	
P64-18	D	None	AS	1	
P65-18	D	None	AS	1	
P66-18	AM	AMPC	AMPC	1	
			–	2 (See Note 2)	
P70-18	AS	None	D	1, 2, 3 (Assembly Action)	
P79-18 Part I	D	None	AS	1	
P82-18 Part I	D	None	AMPC	1, 2	
P82-18 Part II	D	None	AMPC	1, 2	
P91-18	AS	AMPC	AMPC	1, 2	
P94-18	D	None	AMPC	1	
P96-18	AM	AMPC	AMPC	1	
			AS	2	
			D	3 (Assembly Action)	
			–	4 (See Note 2)	
P99-18	D	None	AMPC	1	
P104-18	D	None	AMPC	1	
P108-18	AM	None	AS	1	
P116-18	AM	None	D	1, 2, 3	
P120-18	AM	AMPC	AMPC	1	
P121-18	D	None	AS	1	
P123-18	D	None	AS	1	
			D	2	
P124-18	D	None	AS	1	
			D	2	
P125-18	D	None	AMPC	1	
			AS	2	
			D	3	
P126-18	AS	None	D	1	

PROPOSED CHANGE	COMMITTEE HEARING ACTION	ALLOWABLE SUBSEQUENT MOTIONS PER SECTION 7.5.8.6 (CP# 28)	PUBLIC COMMENTS		FINAL ACTION
			DESIRED ACTION	PUBLIC COMMENT NUMBER	
P131-18 Part I	D	<i>None</i>	AMPC	1	
P131-18 Part II	D	<i>None</i>	AMPC	1	
P132-18 Part I	D	<i>None</i>	AMPC	1	
P132-18 Part II	D	<i>None</i>	AMPC	1, 2	

INTERNATIONAL RESIDENTIAL CODE – PLUMBING

P1-18 Part II	D	<i>None</i>	AMPC	1	
P46-18 Part II	D	<i>None</i>	AS	1, 2	
P109-18 Part II	AM	<i>None</i>	AS	1	
RP3-18	D	<i>None</i>	AMPC	1	
RP10-18	AM	<i>AMPC</i>	AMPC	1	
			D	2	
RP13-18	D	<i>None</i>	AMPC	1	
			AS	2	
RP16-18	D	<i>None</i>	AMPC	1	
			AS	2	

UPDATES TO THE 2018 DISCUSSION GUIDE & PUBLIC COMMENT AGENDA

Updated 10/01/2018

2018 ICC CODE DEVELOPMENT CYCLE TECHNICAL UPDATES TO THE 2018 PUBLIC COMMENT AGENDA FOR THE PROPOSED CHANGES TO THE:

INTERNATIONAL BUILDING CODE®
-FIRE SAFETY
-GENERAL
-STRUCTURAL

INTERNATIONAL FIRE CODE®

INTERNATIONAL FUEL GAS CODE®

INTERNATIONAL MECHANICAL CODE®

INTERNATIONAL PLUMBING CODE®

INTERNATIONAL RESIDENTIAL CODE®
-BUILDING

SUMMARY OF UPDATES:

INTERNATIONAL BUILDING CODE:

GENERAL

- G108-18: Removed extra reason statements to Public Comment 94
Removed extra reason statements to Public Comment 95
Add Public Comment 104
- G121-18: Portions of bibliography were missing from Proposed Code Change
- G133-18: Change instruction line to Public Comment 1
- G151-18: Some images did not display in Public Comment 2

FIRE SAFETY

- Hearing Order F22-18 dropped down to the next line
- FS83-18: Change made to the Proponent line of Public Comment 1
- FS108-18: Withdrawn by Proponent

STRUCTURAL

- S21-18: Change made to the Proponent line of Public Comment 1

INTERNATIONAL FIRE CODE:

- F95-18: Change made to the Proponent line of Public Comment 1
- F276-18: Change made to the request of Public Comment 1
- F300-18: Replace Public Comment 1
- F304-18: Withdrawn by Proponent

INTERNATIONAL FUEL GAS CODE:

- FG1-15: Portions of the original code change did not display

INTERNATIONAL MECHANICAL CODE:

- M3-18: Definition in Public Comment 1 should be underlined
- M4-18: Portions of definition in Public Comment 1 should be underlined
- M23-18: Change made to the Proponent line of Public Comment 1
- M72-18: Correction to Section 607.4 in Public Comment 1
- M120-18: Withdrawn by Proponent

INTERNATIONAL RESIDENTIAL CODE:

BUILDING

- RB5-18: Public Comment 1 has corrections to the text
Change made to the Proponent line of Public Comment 2

INTERNATIONAL PLUMBING CODE:

P14-18: Change made to the Proponent line of Public Comment 3
P15-18: Change made to the request of Public Comment 4
P65-18: Change made to the Proponent line of Public Comment 1
P132-18 Part II: Correction to the Public Comment number

INTERNATIONAL BUILDING CODE –GENERAL

Updated 10/01/2018

G108-18: Removed extra reason statements to Public Comment 94

G108-18

Public Comment 94:

Proponent: Stephen Skalko, Stephen V. Skalko, P.E. & Associates, LLC, representing Stephen V. Skalko, P.E. & Associates, LLC (svskalko@svskalko-pe.com) requests Disapprove.

Commenter's Reason: G108-18 should be disapproved because the issue of fire resistance of connections for mass timber construction has not been sufficiently addressed in this proposal. The present code requirements for nominal heavy timber members have an approximate 1-hour fire resistance. This code proposal adds three new types of heavy timber construction (Types IV-A, IV-B and IV-C) which have fire resistance requirements for the primary structural frame and secondary members for at least two hours (three-hours for Type IV-A primary members). There is no language to direct the code user on what should be provided or expected to protect the connections for these higher fire resistances. The topic of fire resistance protection of connections has been treated too lightly considering the importance of these connections for maintaining structural stability for these taller mass timber buildings during and after a fire incident.

The ICC Tall Wood Building Committee was told that there are proprietary connections that have been used in Europe to accomplish these higher fire resistance ratings required. However, documentation in the form of fire tests, technical reports or other reference material has not been provided to substantiate these claims.

And the CLT Handbook available for designers is not much help either [CLT Cross-Laminated Timber Handbook US Edition, 2013]. In Chapter 8, Fire, Section 5 Connections the handbook states:

Due to the high thermal conductivity of steel, metallic fasteners and plates directly exposed to fire may heat up and conduct heat into the wood members. The wood components may then experience charring on the exposed surface and around the fastener. As a result, the capacity of the metallic connection is reduced to the strength reduction of the steel fasteners at elevated temperatures and the charring of the wood members. Therefore, where a fire resistance rating is required by the IBC, connections and fasteners are required to be protected from fire exposure by wood, gypsum board or other protection approved for the required rating .

While the protection cited may increase the fire endurance of the metallic portions of the connections, the connection elements will still be subjected to elevated temperatures during a fire event. Data has not been provided to demonstrate what those elevated temperatures will be with the various protection systems noted so there is no way to evaluate the potential for internal charring of connector holes. There is also no methodology provided that would allow for a comprehensive post-fire evaluation of the remaining structure.

A technical research report on connections for tall wood buildings prepared for the National Research Council of Canada reported that the fire resistance for concealed connections may be on the order of 1 to 1-1/2 hours [Canadian Commission on Building and Fire Codes, Standing Committee on Fire Protection, Review of Fire Resistant Design of Connections, January 2017, page 8]. The report conclusion suggests that some extra overlay of wood may be necessary for the 2-hour and 3-hour fire resistance of mass timber provisions proposed by the ICC TWB Committee. This is not to suggest that 2-hour fire or 3-hour resistances of connections cannot be achieved. But, connections must be given extra attention and standard methods for the industry may not be sufficient.

This extra attention is what is lacking in the ICC TWB Code Proposals. Nothing in the proposals brings to the attention of the designer or code official this very important fire aspect of providing proper fire rated connections for the prescriptive CLT requirements. Before the membership approves provisions for taller mass timber buildings, the ICC TWB Committee should have the opportunity to perform their due diligence by a review of connections with fire resistances greater than 1-hour for mass timber buildings based on fire tests reports, technical reports or other reference material documenting that 2-hour and 3-hour fire resistance ratings can be achieved.

Because of the need to study in more depth what and how 2-hour and 3-hour fire rated connections for these proposed mass timber buildings is accomplished, this proposal should be DISAPPROVED and sent back to the ICC TWB Committee to address this critical shortcoming.

G108-18: Removed extra reason statements to Public Comment 95**G108-18***Public Comment 95:*

Proponent: Jason Krohn, Precast/Prestressed Concrete Institute, representing Precast/Prestressed Concrete Institute (jkrohn@pci.org) requests Disapprove

Commenter's Reason: G108-18 should be disapproved because the long-term performance of adhesives used in the cross-laminated timber after exposure to fire have not been thoroughly examined. Presentations on the results of fire tests performed on CLT by the National Research Council of Canada for the National Fire Protection Research Foundation were given to the ICC TWB Committee. One of the areas of concern that showed up in Phase 2 of those tests was delamination of a CLT floor/ceiling panel during the cooldown period of a test which resulted in a regrowth of the fire within the compartment. The delamination was attributed to a bonding failure of the adhesive that had been used in the manufacture of the CLT floor/ceiling panel after exposure to high heat.

To address this test finding, revisions to the adhesive requirements in 2015 edition of ANSI/APA PRG 320, Standard for Performance Rated Cross-Laminated Timber were incorporated through the APA standards process. PRG 320-2015 is referenced in the IBC as the performance standard for CLT members. In the 2018 edition of PRG 320 the adhesives used for CLT panels are required to be evaluated and meet criteria in the Annex B of the Standard titled Practice for Evaluating Elevated Temperature Performance of Adhesives Used in Cross-Laminated Timber. However, those criteria are for the purpose of evaluating the performance of adhesives used in CLT exposed to heat and flame under controlled conditions (Section B1.4). The pass/fail criteria in Section B1.3 expect the CLT floor-ceiling slab to sustain the applied load during the specified fire exposure for a period of 240 minutes without char layer fall-off resulting in fire regrowth during the cooling phase of a fully developed fire .

While this testing may be sufficient to show that an adhesive would have prevented delamination for the specified time period, it does not in any way demonstrate that the adhesives are still capable of providing the long term structural performance after exposure to elevated temperatures experienced during a fire event. And, neither does ANSI 405, Standard for Adhesives for Use in Structural Glue Laminated Timber, which is referenced in PRG 320, address long-term performance of adhesives that have been subjected to fire exposure. Like PRG 320, Section 2.1.7 of ANSI 405 is intended to qualify adhesives according to the CSA 0177 small scale flame test to avoid delamination due to intensive heat, such as fire exposure (C2.1.7). No methodology has been provided that would allow for a comprehensive post-fire evaluation of the remaining structure.

Before the membership approves provisions for taller mass timber buildings the ICC TWB Committee should have the opportunity to perform their due diligence by a review of the long-term performance of adhesives that have been subjected to fire exposure. This is especially important for buildings that may be as tall as 18-stories.

Because of the need to study in more depth the long-term performance of adhesives that have been subjected to fire exposure, this proposal should be DISAPPROVED and sent back to the ICC TWB Committee to address this critical issue.

Updated 10/01/2018

G108-18: Public Comment 104 added**G108-18***Public Comment 104:*

Proponent: Richard Popp, Meyer Concrete Pumping & Conveyor Service, LLC., representing Meyer Concrete Pumping & Conveyor Service, LLC requests Disapprove.

Commenter's Reason: Allowing wood structures to be built above the level of fire department access is a serious mistake. Wood does not offer the resilience and fire protection of non-combustible alternatives like concrete and steel. Cross-Laminated Timber chars in a fire; however, charring is not equivalent to noncombustible. Note: if the char rate is 1" per hour in a fire, then after 2 hours in a fire, a 6" thick CLT wood load bearing wall will only have 2" of structural material left. This is not acceptable and is not addressed in the code change proposals. Should you pass this, you are putting countless lives and making an even larger impact on the generations to come as the world's forests are being depleted. Be smart about this and do not pass this.

Cost Impact: The net effect of the public comment and code change proposal will not increase or decrease the cost of construction
Results in no changes to current requirements.

Updated 10/01/2018

G121-18: Portions of bibliography were missing from Proposed Code Change

G121-18

Proponent: Peter Valkov, City of Fargo, ND, representing City of Fargo, North Dakota (pvalkov@cityoffargo.com);
Christine Rose, City of Fargo, representing City of Fargo (crose@cityoffargo.com)

Bibliography:

1. <http://www.bristolite.com/blog/natural-light-and-education-the-benefits-of-daylighting-for-schools-and-colleges/>
2. <https://www.corbettinc.com/blog/2017/4/26/our-top-3-reasons-natural-light-benefits-students-schools>
3. <https://www.aia.org/articles/19541-six-design-decisions-that-will-entice-client:31>
4. <https://www.aia.org/press-releases/80866-aia-selects-2016-upjohn-research-initiative->
5. <http://www.healthyschools.org/downloads/Daylighting.pdf>
6. <https://globaldigitalcitizen.org/healthy-classrooms-infographic>
7. <http://www.sunlightinside.com/light-and-health/natural-light-improves-student-performance/>
8. <https://aiaa.aia.org/courses/aia2030-online-series-course-6-daylighting-and-integrated-lighting-design>
9. https://www.google.com/search?safe=strict&biw=1381&bih=796&tbn=isch&sa=1&ei=aPITWsilMqucjwTa5bHoCg&q=natural+light+schools&oq=natural+light+schools&gs_l=psy-ab.3...33783.35478.0.36292.6.5.1.0.0.0.96.419.5.5.0...0...1c.1.64.psy-ab..0.0.0...0.EFczITCz0e8
10. Bellia, L., A. Pedace, and G. Barbato, "Lighting in Educational Environments: An Example of A Complete Analysis of The Effects of Daylighting and Electric Light on Occupants." Building and Environment 68 (2013): 50-65
11. Day, Christopher, and Anita Midjber. Environment and Children: Passive Lessons From the Everyday Environment. Oxford, UK: Architectural Press, 2007.
12. Demir, Ayse. "Impact of Daylighting on Student and Teacher Performance." Journal of Educational Instructional Studies in the World 3, no.1 (2013)
13. Heschong, Lisa, Roger L. Wright, and Stacia Okura. "Daylighting Impacts on Human Performance in School." Journal of the Illuminating Engineering Society 31, no.2 (2002): 101-114.
<http://www.tandfonline.com/doi/pdf/10.1080/00994480.2002.10748396#.UokrsG TF2TI>.
14. <https://www.corbettinc.com/blog/2017/4/26/our-top-3-reasons-natural-light-benefits-students-schools>

Updated 10/01/2018

G133-18: Change instruction line to Public Comment 1

G133-18

Proponent: Eirene Knott, representing Metropolitan Kansas City Chapter of the ICC (eirene.knott@brrarch.com);
David Collins (dcollins@preview-group.com) requests As Modified by This Public Comment.

Replace as follows:

G151-18: Images missing from Public Comment 2

G151-18

Proponent: Ed Kullik, representing ICC Building Code Action Committee (bcac@iccsafe.org) requests As Modified by This Public Comment.

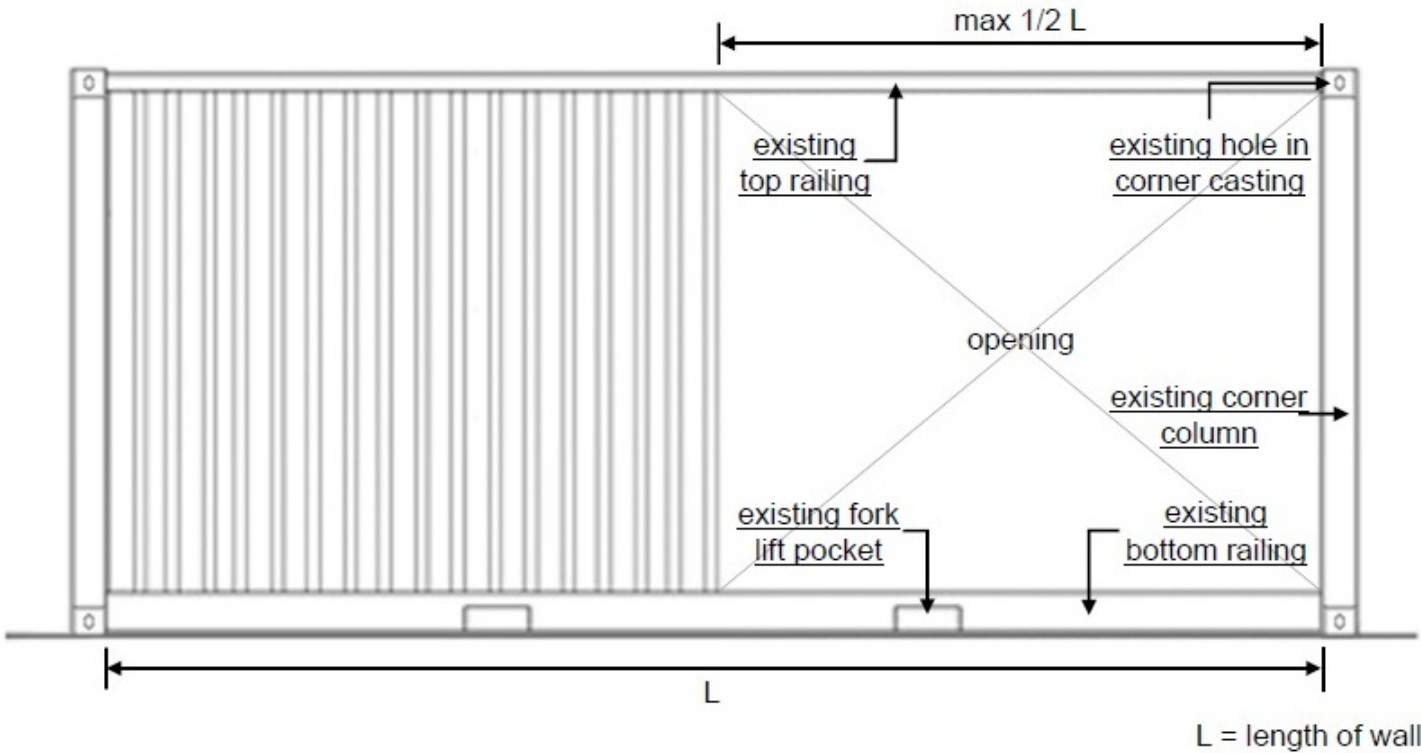
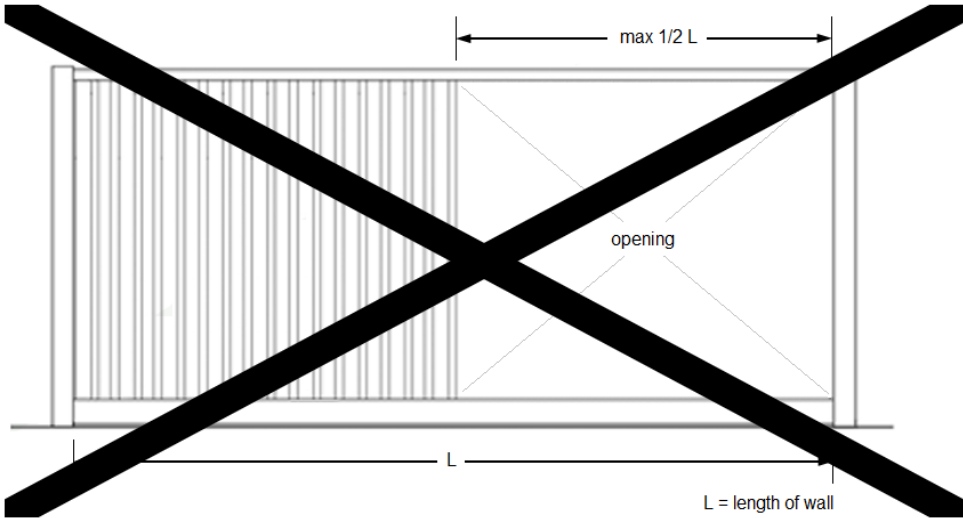

3114.8.5.3(1)
Bracing Unit Distribution--Maximum Linear Length

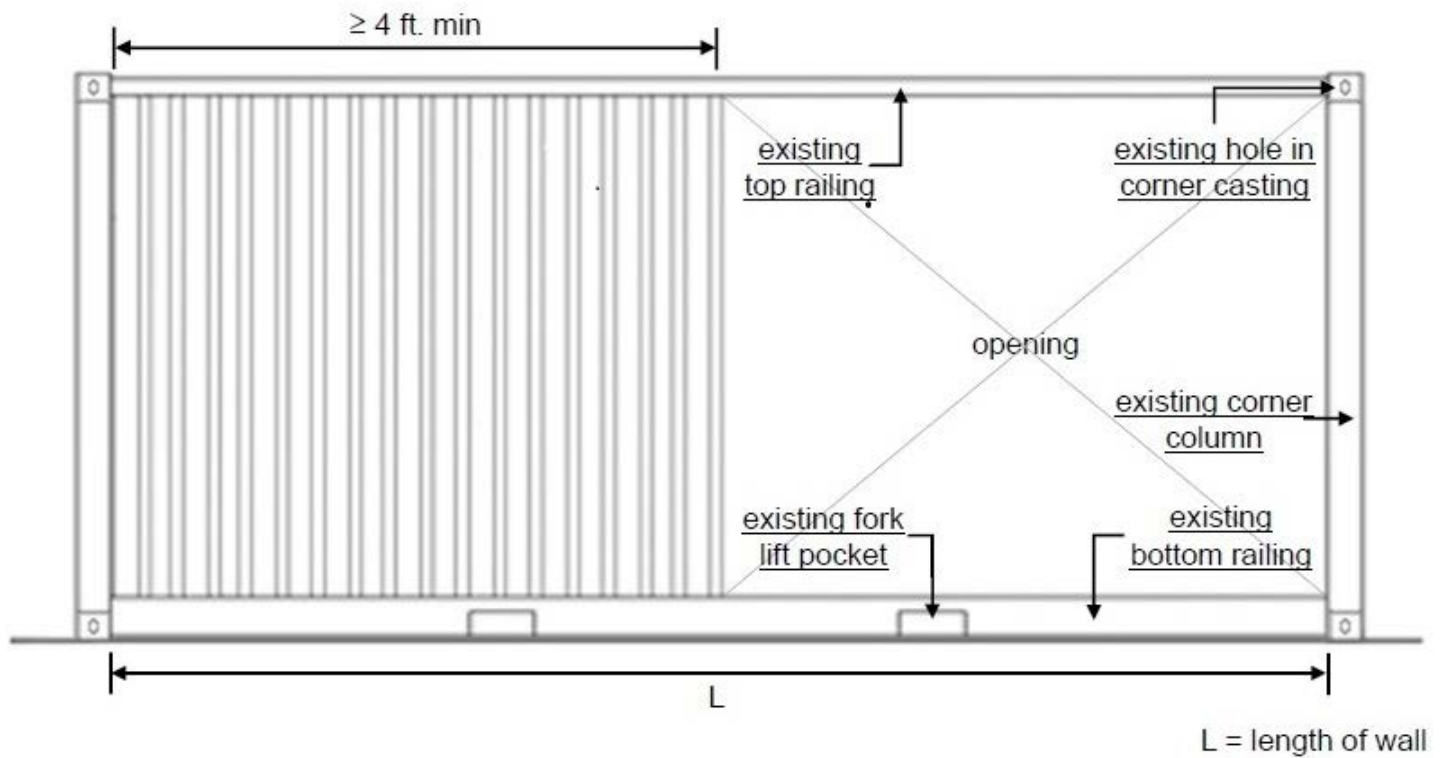
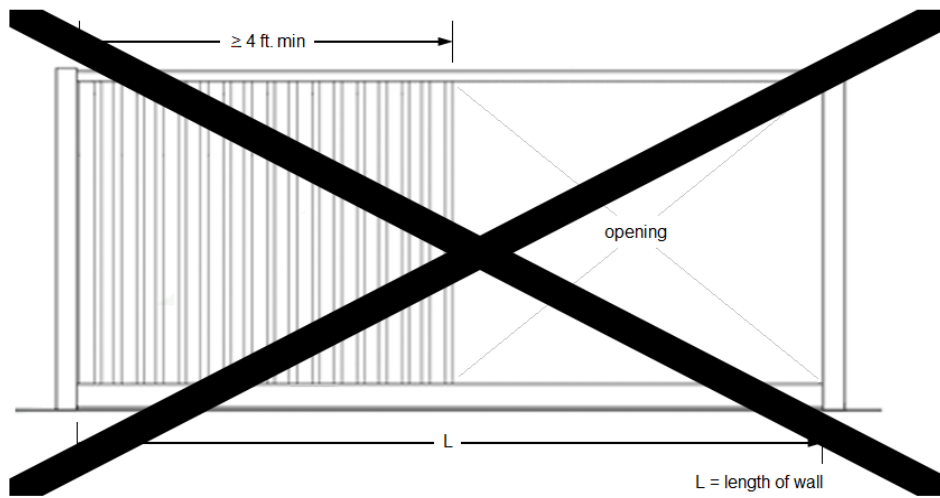

3114.8.5.3(2)
Bracing Unit Distribution -- Minimum Linear Length

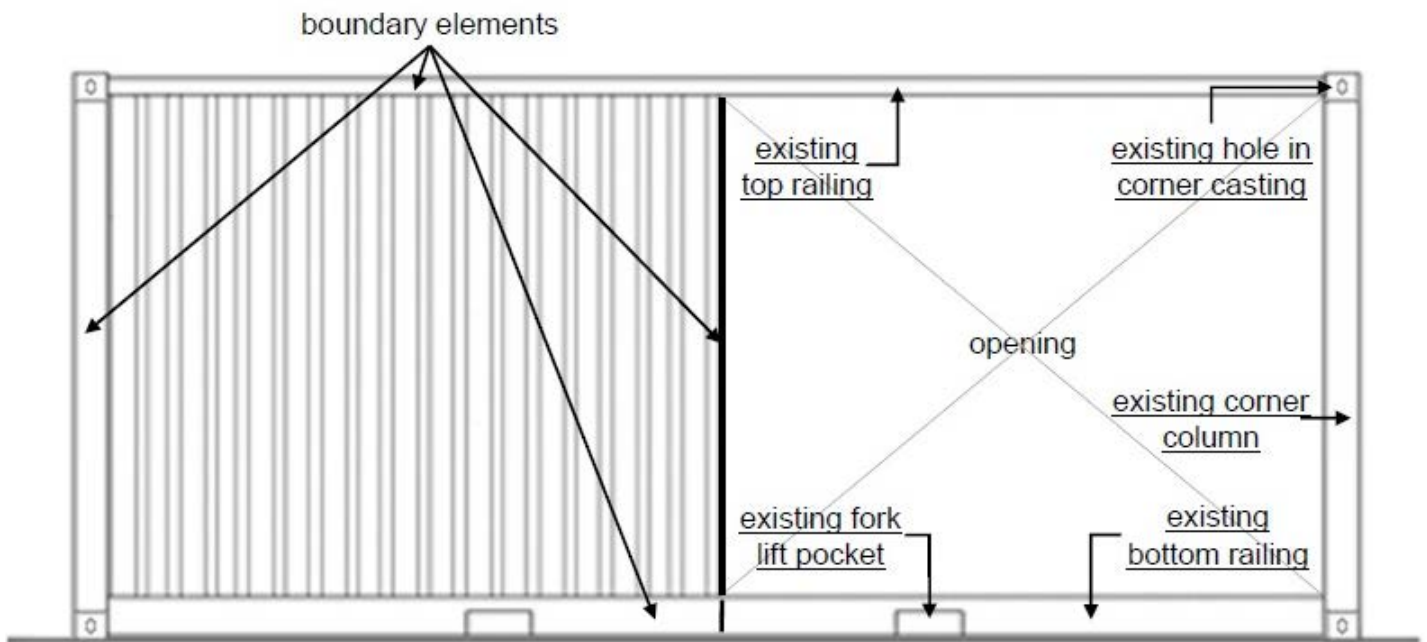
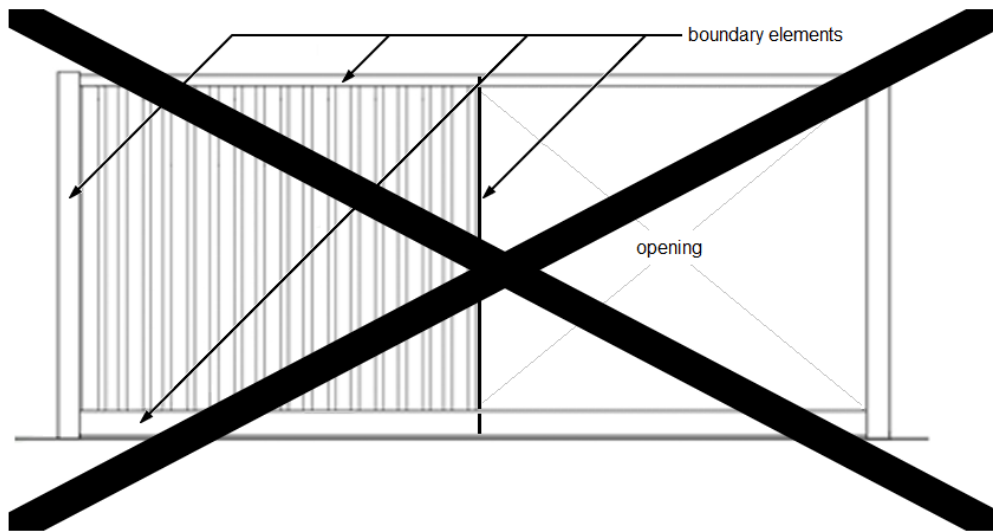

3114.8.5.3(3)
Bracing Unit Distribution -- Boundary Elements

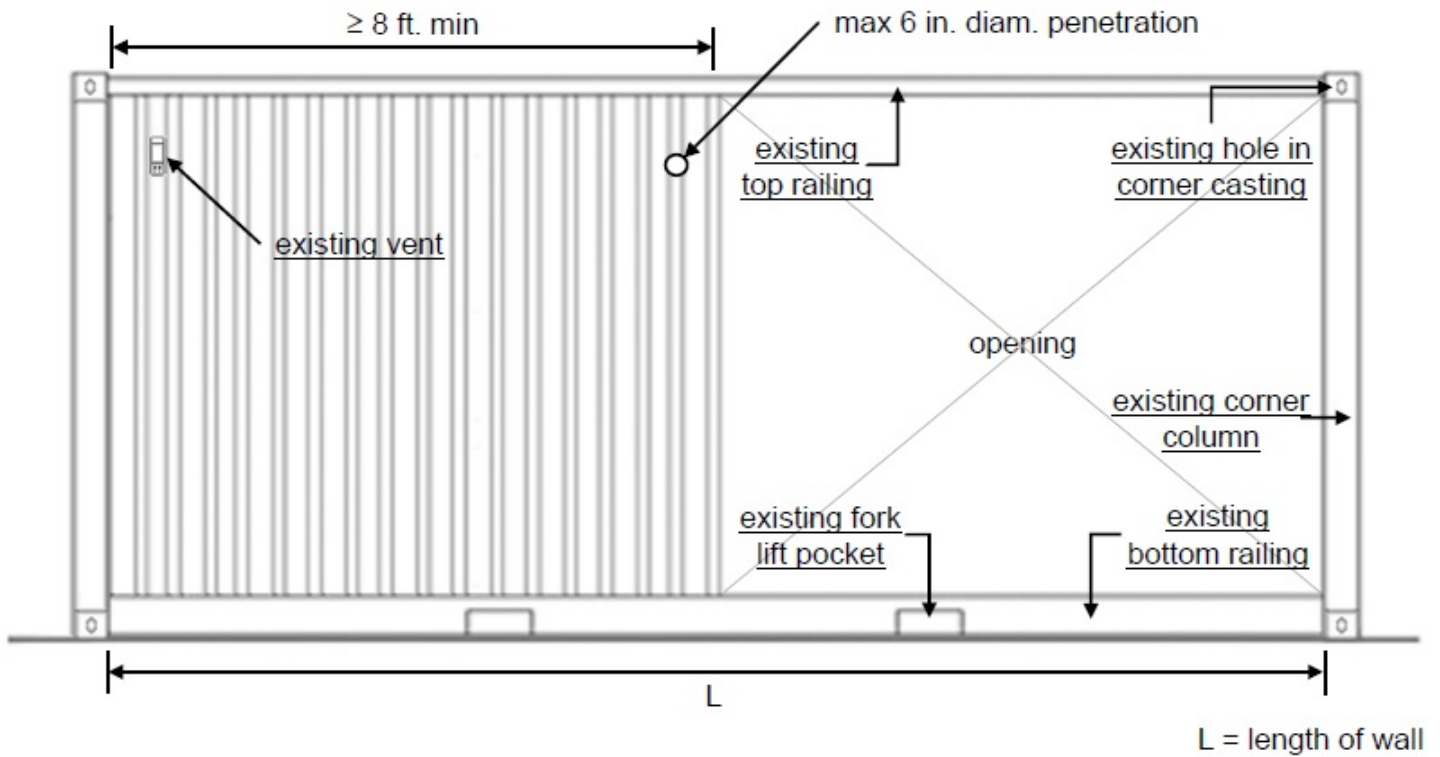
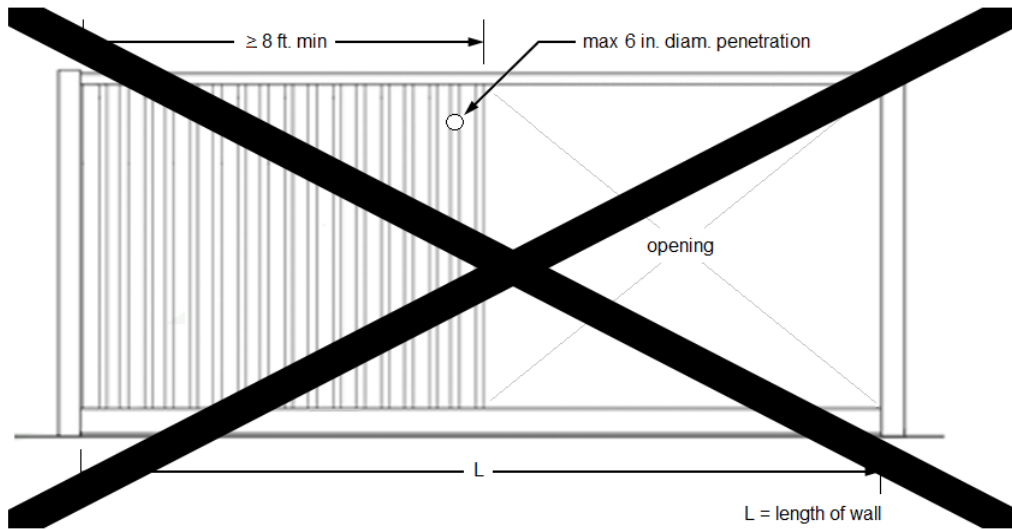

**3114.8.5.3(4)
Bracing Unit Distribution -- Penetration Limitations**

INTERNATIONAL BUILDING CODE – FIRE SAFETY

Updated 10/01/2018

FS83-18: Change made to the Proponent line of Public Comment 1

FS83-18

Public Comment 1:

Proponent: Julius Ballanco, JB Engineering and Code Consulting, P.C., representing **Bradley Corp.** (jbenigneer@aol.com); Andrew Klein, representing Building Owners and Managers Association International (andrew@asklein.com); Matt Sigler, Plumbing Manufacturers International, representing Plumbing Manufacturers International (msigler@safep plumbing.org); Ramiro Mata, representing American Society of Plumbing Engineers - Sr. Director of Technical and Regulatory Affairs (rmata@aspe.org) requests As Submitted.

Updated 10/01/2018

FS108-18

Withdrawn by Proponent

INTERNATIONAL BUILDING CODE – STRUCTURAL

Updated 10/01/2018

S21-18: Change made to the Proponent line of Public Comment 1

S21-18

Public Comment 1:

Proponent: Margo Thompson, Newport Ventures, representing National Multifamily Housing Council (mthompson@newportventures.net); Dan Buuck, National Association of Home Builders (dbuuck@nahb.org) requests Disapprove.

INTERNATIONAL FIRE CODE

Updated 10/01/2018

IFC: F22-18 moved from the same line as F92-18 Part II

IFC

(See page 745)

F8-18

F13-18

F17-18

F18-18

F21-18

F92-18 Part I

F92-18 Part II

F22-18

F23-18

Updated 10/01/2018

F95-18: Change made to the Proponent line of Public Comment 1

F95-18

Public Comment 1:

Proponent: Julius Ballanco, JB Engineering and Code Consulting, P.C., representing Bradley Corp. (jbengineer@aol.com); Andrew Klein, representing Building Owners and Managers Association International (andrew@asklein.com) requests As Modified by This Public Comment.

Updated 10/01/2018

F276-18: Change to the request to Public Comment 1

F276-18

Public Comment 1:

Proponent: Linda Purcell, representing architecture PML, Inc requests Disapprove.

Updated 10/01/2018

F300-18: Replace Public Comment 1

F300-18

Public Comment 1:

Proponent: Robert Solomon, NFPA, representing National Fire Protection Association requests Disapprove

Commenter's Reason: Although NFPA would urge deletion of all of sub-item 4, we understand that is not an appropriate action procedurally. We have recommended an action of disapproval as NFPA does not want to be seen as endorsing any code language related to the possession or sale of consumer fireworks to the public. This section as modified by the committee is referencing an outdated edition of an NFPA Standard, which negates over ten years of code development by both the NFPA Technical Committee on Pyrotechnics and the NFPA Standards Council. In 2007 the Fire Protection Research Foundation (FPRF) published a hazard assessment research report (see bibliography). As a result of that report, the NFPA Standards Council identified nine safety concerns

that were outlined in their October 2008 decision on this subject. In this decision they identified a process by which a series of approval committees would be tasked with reviewing any related research, reports, findings, or combination thereof, which would substantiate and provide a scientific basis for the nine areas identified; one of which included the submission of sprinkler design criteria for the protection of retail facilities that store and sell consumer fireworks. After nearly ten years and multiple requests without an adequate response, in their 2014 decision, the NFPA Standards Council temporarily withdrew NFPA 1124 and cease development and removed all language pertaining to storage and retail sale of consumer fireworks. It is the view of the NFPA Standards Council that there should be no standards for the storage and retail sale of consumer fireworks until such time that the remaining research needs have been addressed. If the IFC is to address the retail sale of consumer fireworks, it must do so without referencing a 12 year-old standard which contains requirements that have not been scientifically proven. See bibliography for the 2008 and 2014 Standards Council Decisions.

Bibliography:

FPRF Report

<https://www.nfpa.org/-/media/Files/News-and-Research/Resources/Research-Foundation/pyrotechnicsliteraturereview.ashx?la=en>
SC Decision 08-19

<https://www.nfpa.org/-/media/Files/Codes-and-standards/standards-council/fd08738d0819nfpa1124.ashx?la=en>
hash=549EAD8F126BE580E2A021F056DFB94097289D0F

SC Decision 14-1

https://www.nfpa.org/Assets/files/AboutTheCodes/1124/FD14_3_31_D14_1_APA_NFPA1124.pdf

Cost Impact: The net effect of the public comment and code change proposal will not increase or decrease the cost of construction Results in no changes to current requirements.

Staff Analysis: Public comments to code change proposals F300-18 and F303-18 propose revisions to Section 5601.1.3 and 5609. The actions taken need to address these differences.

Updated 10/01/2018

F304-18

Withdrawn by Proponent

INTERNATIONAL FUEL GAS CODE

Updated 10/01/2018

FG1-18: Highlighted portion of the code change proposal did not display in the Public Comment Agenda

FG1-18

Proposed Change as Submitted

Proponent: James Ranfone, representing American Gas Association (jranfone@aga.org)

Revise as follows

[M] PIPING. Where used in this code, "piping" refers to either pipe or tubing, or both.

Pipe. A rigid conduit used to convey fuel gas or other fluids.

Tubing. Semirigid conduit used to convey fuel gas or other fluids.

INTERNATIONAL MECHANICAL CODE

Updated 10/01/2018

M3-18: Definition should appear underlined

M3-18

Public Comment 1:

Proponent: David Collins, representing International Code Council Sustainability, energy and high performance code action committee (sehpcac@iccsafe.org) requests As Modified by This Public Comment.

R-VALUE (THERMAL RESISTANCE) A measure of the ability to retard the flow of heat. The R-value is the reciprocal of thermal conductance. The inverse of the time rate of heat flow through a body from one of its bounding surfaces to the other surface for a unit temperature difference between the two surfaces, under steady state conditions, per unit area (h ft² F/Btu) [(m² K)/W].

Updated 10/01/2018

M4-18: Highlighted portions of definition should appear underlined

M4-18

Public Comment 1:

Proponent: Connor Barbaree, representing ASHRAE (cbarbaree@ashrae.org) requests As Modified by This Public Comment.

FLAMMABILITY CLASSIFICATION (REFRIGERANT). The alphabetical/numerical designation used to identify the flammability of refrigerants.

Indicates a refrigerant with no flame propagation.

Indicates a refrigerant with lower flammability and lower burning velocity.

Indicates a refrigerant with lower flammability.

Indicates a refrigerant with higher flammability.

Updated 10/01/2018

M23-18: Change made to the Proponent line of Public Comment 1

M23-18

Public Comment 1:

Proponent: Julius Ballanco, JB Engineering and Code Consulting, P.C., representing **Self** (jbengineer@aol.com); Anthony Floyd, City of Scottsdale, representing City of Scottsdale (afloyd@scottsdaleaz.gov) .requests As Modified by This Public Comment.

Updated 10/01/2018

M72-18: Correction to Section 607.4 in Public Comment 1

M72-18

Public Comment 1:

Proponent: William Koffel, representing Air Movement and Control Association (wkoffel@koffel.com) requests As Modified by This Public Comment.

607.4 Access and identification.

~~Fire Access and identification of fire and smoke dampers shall be provided with an *approved* means of access, to permit inspection and maintenance of the damper and its operating parts. Dampers equipped with fusible links, internal operators, or both shall be provided with an access door that is not less than 12 inches (305mm) square or provided with a removable duct section. The access shall not affect the integrity of fire resistance-rated assemblies. The access openings shall not reduce the fire resistance rating of the assembly. Access points shall be permanently identified on the exterior by a label having letters not less than 0.5 inch (12.7 mm) in height reading: FIRE/SMOKE DAMPER, SMOKE DAMPER or FIRE DAMPER. Access doors in ducts shall be tight fitting and suitable for the required duct construction comply with **Sections 607.4.1 through 607.4.2.**~~

Updated 10/01/2018

M120-18

Withdrawn by Proponent

INTERNATIONAL RESIDENTIAL CODE – BUILDING

Updated 10/01/2018

RB5-18: Correction to highlighted text in Public Comment 1.

RB5-18

Public Comment 1:

Proponent: Connor Barbaree, representing ASHRAE (cbarbaree@ashrae.org) requests As Modified by This Public Comment.

Mechanical:

1. Portable heating *appliances*.
2. Portable ventilation *appliances*.
3. Portable cooling units.
4. Steam, hot- or chilled-water piping within any heating or cooling *equipment* regulated by this code.
5. Replacement of any minor part that does not alter approval of *equipment* or make such *equipment* unsafe.
6. Portable evaporative coolers.
7. Self-contained refrigeration systems containing 10 pounds (4.54 kg) or less of ~~non-flammable (A-1) refrigerant~~ Group A1 or A2L refrigerants in accordance with Table 1103.1 of the IMC.
8. Self-contained refrigerating systems, containing Group A1 or A2L refrigerants in accordance with Table 1103.1 of the IMC that are actuated by a motor of 1 horsepower (746W) or less.
9. Self-contained refrigerating systems, containing 0.331 pounds (150 g) or less of Group A2 or A3 refrigerants in accordance with Table 1103.1 of the IMC

Updated 10/01/2018

RB5-18: Change made to the Proponent line of Public Comment 2

RB5-18

Public Comment 2:

Proponent: Julius Ballanco, JB Engineering and Code Consulting, P.C., representing Daikin US (jbengineer@aol.com); Donald Surrena, National Association of Home Builders, representing National Association of Home Builders(dsurrena@nahb.org) requests Disapprove.

INTERNATIONAL PLUMBING CODE

Updated 10/01/2018

P14-18: Change made to the Proponent line of Public Comment 2

P14-18

Public Comment 3:

Proponent: Bryan Romney, representing self, requests Disapprove.

Updated 10/01/2018

P15-18: Change made to the request of Public Comment 4

P15-18

Public Comment 1:

Proponent: Bryan Romney, representing self, requests As Modified by Committee.

Updated 10/01/2018

P65-18: Change made to the Proponent line of Public Comment 1

P65-18

Public Comment 1:

Proponent: Julius Ballanco, representing Bradley Corp. (jbengineer@aol.com) requests As Submitted.

Updated 10/01/2018

P132-18 Part II: Correction to the Public Comment number

P132-18 Part II

Public Comment 2:

Proponent: Pennie Feehan, representing Plumbing, Mechanical, and Fuel Gas Code Action Committee (pmgac@iccsafe.org); Dave Cantrell (dave.cantrell.codes@gmail.com); Paul Gulletson (paul.gulletson@csagroup.org) requests As Modified by This Public Comment
