

# P2905.3

## Length of Hot Water Piping to Fixtures

**CHANGE TYPE:** Addition

**CHANGE SUMMARY:** The code now limits the length of hot water piping serving fixtures.

**2021 CODE: P2905.3 Hot water supply to fixtures.** The developed length of hot water piping, from the source of hot water to the fixtures that require hot water, shall not exceed 100 feet (30 480 mm). Water heaters and recirculating system piping shall be considered to be sources of hot water.

**CHANGE SIGNIFICANCE:** A new section limits the hot water supply line length to 100 feet measured from the source of hot water to the fixtures that require hot water. This provision is similar to existing language in IPC Section 607.2, except the IPC limits the length to not greater than 50 feet. Hot water supply lines greater than 100 feet waste water (proportional to pipe size) while occupants wait for hot water to reach fixtures for bathing, washing and culinary purposes. Even when hot water supply lines are insulated, the hot water remaining in the lines between demand periods cools down. Limiting the length and consequent volume of heated water in the supply lines reduces the amount of wasted water and occupant waiting time.

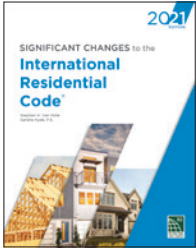

This excerpt is taken from *Significant Changes to the International Residential Code, 2021 Edition*.

The Significant Changes series takes you directly to the most important changes that impact projects. Key changes are identified then followed by in-depth discussion of how the change affects real-world application. Photos, tables and illustrations are included to further clarify application. Available for the IBC, IRC, IFC, IECC and IPC/IMC/IFGC, the Significant Changes publications are very useful training and review tools for transitioning to a new code edition.

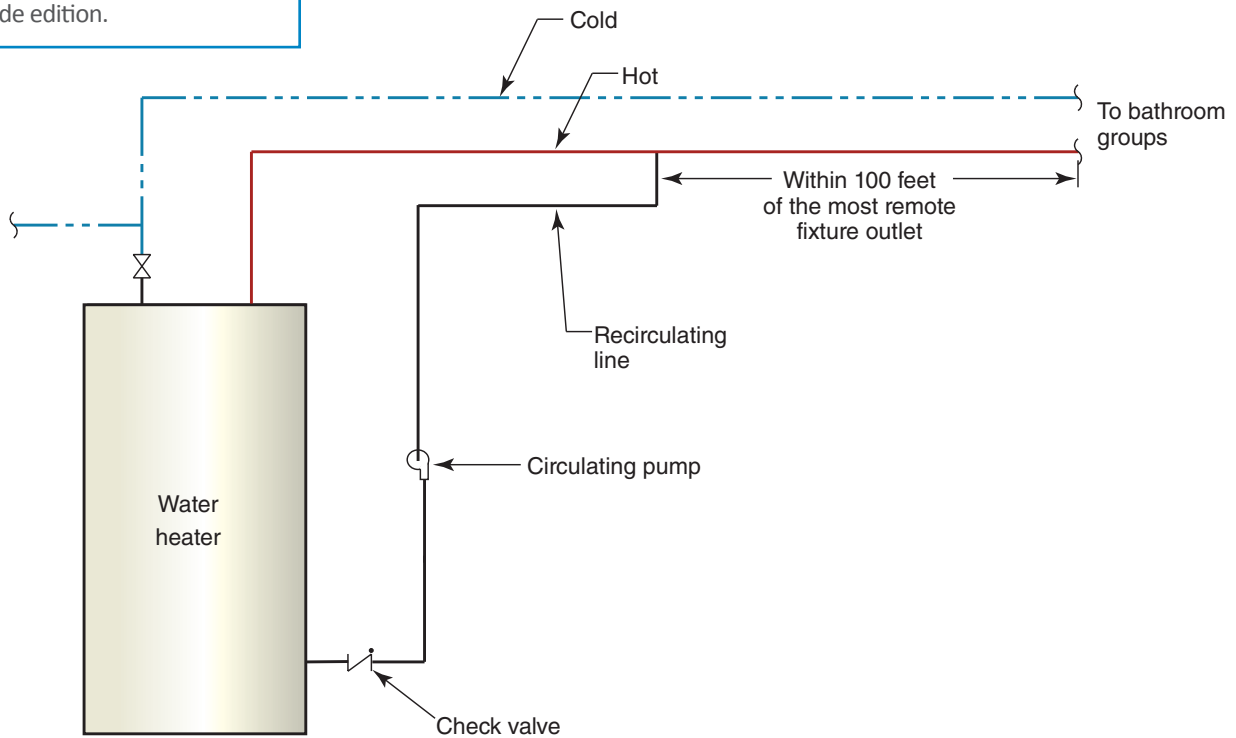

Hot water piping is limited to 100 feet from the source.