



Duct Inspection from Construction to Leakage Testing

Presenter: Mark Terzigni

Tuesday, September 12, 2017

8:00 AM - 11:15 AM



HVAC DUCT CONSTRUCTION STANDARDS 101

ICC 2017

Presented by:

Mark Terzigni
Director of Engineering
Technical Services

HVAC DUCT CONSTRUCTION STANDARDS METAL AND FLEXIBLE



HVAC
DUCT CONSTRUCTION
STANDARDS
METAL AND FLEXIBLE



SHEET METAL AND AIR CONDITIONING CONTRACTORS
NATIONAL ASSOCIATION, INC.
WWW.SMACNA.ORG



Information Required for Duct Construction

1. A comprehensive duct layout indicating sizes, design airflows, pressure class, and routing of the duct system.
2. The types of fittings to be used based on the designer's calculations of fitting losses (i.e., square versus 45° entry taps, conical versus straight taps, etc.).



Information Required for Duct Construction

3. Use of turning vanes or splitter vanes.
4. Location of access doors.
5. Location and type of control and balancing dampers.
6. Location and types of diffusers.
7. Requirements for duct insulation.



Information Required for Duct Construction

8. Location and types of any fire protection device including fire dampers, smoke dampers, combination fire/smoke dampers, and ceiling dampers. Building codes require this information to be shown on the design documents submitted for building permit.



Information Required for Duct Construction

9. Details of offsets required to route ductwork around obstructions (columns, beams, etc.).

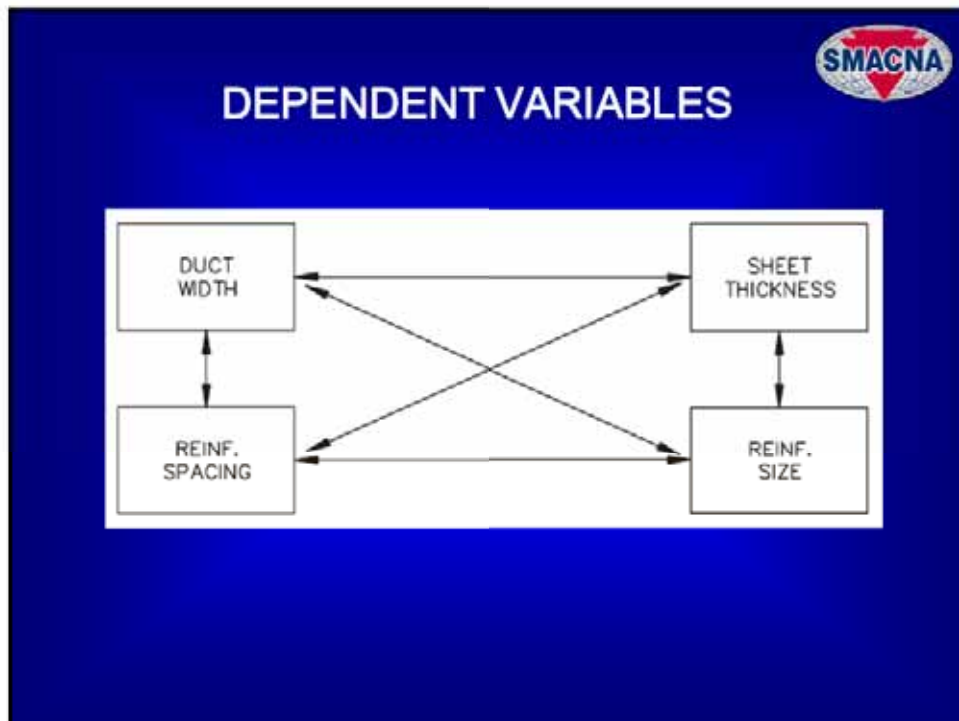
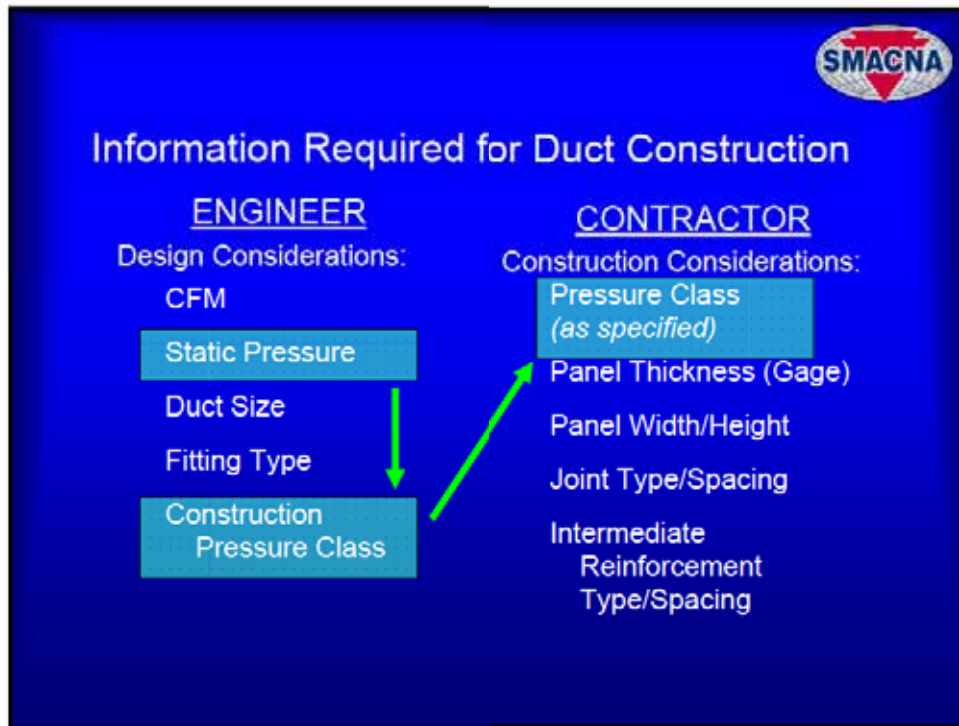



Rectangular Transverse Joints

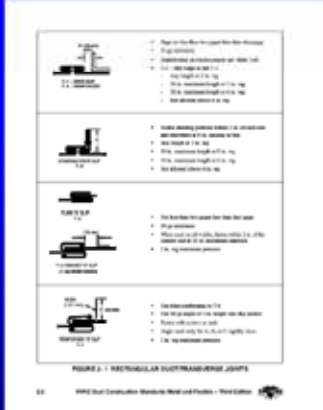



FIGURE 2-1 RECTANGULAR DUCT TRANSVERSE JOINTS

- Figure 2-1
- Pages 2.6-2.9

Rectangular



Rectangular Transverse Joints

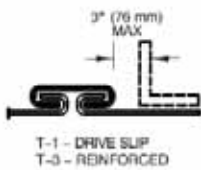

T-1 - DRIVE SLIP
T-3 - REINFORCED

- Gage no less than two gages less than duct gage
- 24 ga minimum
- Qualification as reinforcement per Table 2-48
- T-3 - Slip Gage as per T-1
 - Any length at 2 in. wg
 - 36 in. maximum length at 3 in. wg
 - 30 in. maximum length at 4 in. wg
 - Not allowed above 4 in. wg



STANDING DRIVE SLIP
T-2

- Fasten standing portions within 2 in. of each end and elsewhere at 8 in. spacing or less
- Any length at 2 in. wg
- 36 in. maximum length at 3 in. wg
- 30 in. maximum length at 4 in. wg
- Not allowed above 4 in. wg



Rectangular Transverse Joints

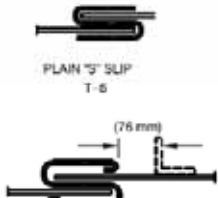

PLAIN "S" SLIP
T-6

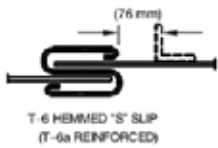

T-6 HEMMED "S" SLIP
(T-6a REINFORCED)

- Not less than two gages less than duct gage
- 24 ga minimum
- When used on all 4 sides, fasten within 2 in. of the corners and at 12 in. maximum intervals
- 2 in. wg maximum pressure

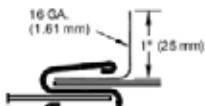

16 GA.
(1.61 mm)

1" (25 mm)

REINFORCED "S" SLIP
T-7

- Use slips conforming to T-6
- Use 16 ga angle of 1 in. height into slip pocket
- Fasten with screws at ends
- Angle used only for A, B, or C rigidity class
- 2 in. wg maximum pressure



Rectangular Transverse Joints

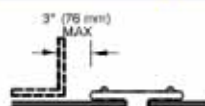

3" (76 mm)
MAX

T-8 DOUBLE "S" SLIP
(T-8 REINFORCED)

- 24 ga for 30 inch width or less
- 22 ga over 30 inch width
- Fasten to each section of the duct within 2 in. from corners and at 6 in. maximum intervals
- 1/8 in. minimum tabs to close corners



STANDING S
T-10



STANDING S (ALT)
T-11





STANDING S (ALT)
T-12

- When using S on all four sides, fasten slip to duct within 2 in. of the corner and at 12 in. maximum intervals
- Any length at 2 in. wg
- 36 in. maximum length at 3 in. wg
- 30 in. maximum length at 4 in. wg
- Not allowed above 4 in. wg



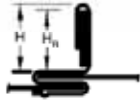

Rectangular Transverse Joints

 <p>STANDING S (BAR REINFORCED) T-13</p>	<ul style="list-style-type: none"> Fasten as per Joint T-10 Standing portion as per T-10 or T-11 to hold Flat Bar Fasten bar stock to the connector within 2 in. of the corner and at 12 in. maximum intervals <div style="border: 2px solid green; padding: 5px;"> <ul style="list-style-type: none"> Any length at 2 in. wg 36 in. maximum length at 3 in. wg 30 in. maximum length at 4 in. wg Not allowed above 4 in. wg </div>
 <p>STANDING S (ANGLE REINFORCED) T-14</p>	<ul style="list-style-type: none"> Fasten as per Joint T-10 Fasten angle to the connector or duct wall within 2 in. of the corner and at 12 in. maximum intervals <div style="border: 2px solid green; padding: 5px;"> <ul style="list-style-type: none"> Any length at 2 in. wg 36 in. maximum length at 3 in. wg 30 in. maximum length at 4 in. wg Not allowed above 4 in. wg </div>

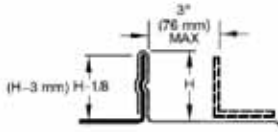

Rectangular Transverse Joints

 <p>STANDING SEAM T-15</p> <p>ANGLE REINFORCED STANDING SEAM T-16</p>	<ul style="list-style-type: none"> Button punch or otherwise fasten within 2 in. of each corner and at 6 in. maximum intervals Seal and fold corners Stagger joints on adjacent sides if using standing seam on all four sides Hammer longitudinal seam at ends of standing seam
 <p>T-21 WELDED FLANGE (T-21a REINFORCED W.F.)</p>	<ul style="list-style-type: none"> Use 1/2 in. minimum flange and end weld Flanges larger than 5/8 in. must be spot welded, bolted, riveted or screwed to prevent separation (2 in. from ends and at 8 in. maximum intervals) On 24, 22 or 20 ga. brace or weld 3/4 x 4 in. rod in corners or provide hangers at every joint



Rectangular Transverse Joints

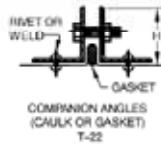

- 1/8 in. minimum flange on duct
- Angles must have welded corners
- Angles must be tack welded, bolted or screwed to the duct wall at 2 in. maximum from the ends and at 12 in. maximum intervals
- Bolt Schedule:
 - 1/8 minimum diameter at 6 in. maximum spacing at 4 in. wg or lower
 - 1/8 in. angle requires 4 in. maximum spacing at 4 in. wg
 - 4 in. maximum spacing at higher pressures

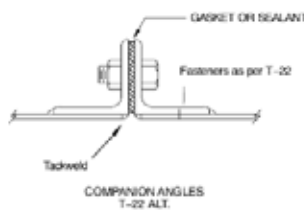

- Hold duct back 1/8 in. from vertical face of the angle and tack weld to the flange along the edge of the duct
- Fasten angle to duct as per T-22
- For additional tightness place sealant between the angle and duct or seal the weld
- If the faces of the angles are flush, thick consistency sealant may be used in lieu of gasket
- Use gasket suitable for the specific service and fit it uniformly to avoid protruding into the duct



Rectangular Transverse Joints



- Assemble per Figure 2-16
- Close corners with minimum 16 ga corner pieces and 3/8 in. bolts min.
- Lock flanges together with 6 in. long clips located within 6 in. of each corner
- Clips spaced at 15 in. maximum for 3 in. wg pressure class or lower
- Clips spaced at 12 in. maximum for 4, 6 and 10 in. wg
- Gasket to be located to form an effective seal

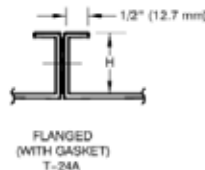

- Bolt, rivet 1 in. maximum from ends and at 6 in. maximum intervals
- Limited to 2 in. wg pressure class
- See Figure 2-16
- Gasket to be located to form an effective seal



Rectangular Transverse Joints



FLANGED
(WITH GASKET)
T-25a



FLANGED
(WITH GASKET)
T-25b

- Assemble per Figure 2-17
- Ratings may be adjusted with EI-rated bar stock or members from Tables 2-29 and 2-30
- Supplemental members may be attached to the duct wall on both sides of the joint
- Single members may be used if they are fastened through both mating flanges
- Gasket to be located to form an effective seal



GASKET
SLIP-ON
FLANGE

- Consult manufacturers for ratings established by performance documented to functional criteria in Chapter 11.



Rectangular Transverse Joints

Duct Wall	26 ga		24 ga		22 ga		20 ga or Heavier	
	Maximum Duct Width (W) and Maximum Reinforcement Spacing (RS)							
Static Pressure	W	RS	W	RS	W	RS	W	RS
½ in. wg	20 in. 18 in.	10 ft N.R.	20 in.	N.R.	20 in.	N.R.	20 in.	N.R.
1 in. wg	20 in. 14 in. 12 in.	8 ft 10 ft N.R.	20 in. 14 in.	8 ft N.R.	20 in. 18 in.	10 ft N.R.	20 in.	N.R.
2 in. wg	18 in.	5 ft	18 in. 12 in.	8 ft N.R.	18 in. 14 in.	10 ft N.R.	18 in.	N.R.
3 in. wg	12 in. 10 in.	5 ft 6 ft	18 in. 10 in.	5 ft N.R.	18 in. 12 in.	5 ft N.R.	18 in. 14 in.	6 ft N.R.
4 in. wg	Not Accepted		16 in. 8 in.	5 ft N.R.	12 in. 8 in.	6 ft N.R.	12 in.	N.R.

Table 2-48 T-1 Flat Drive Accepted as Reinforcement

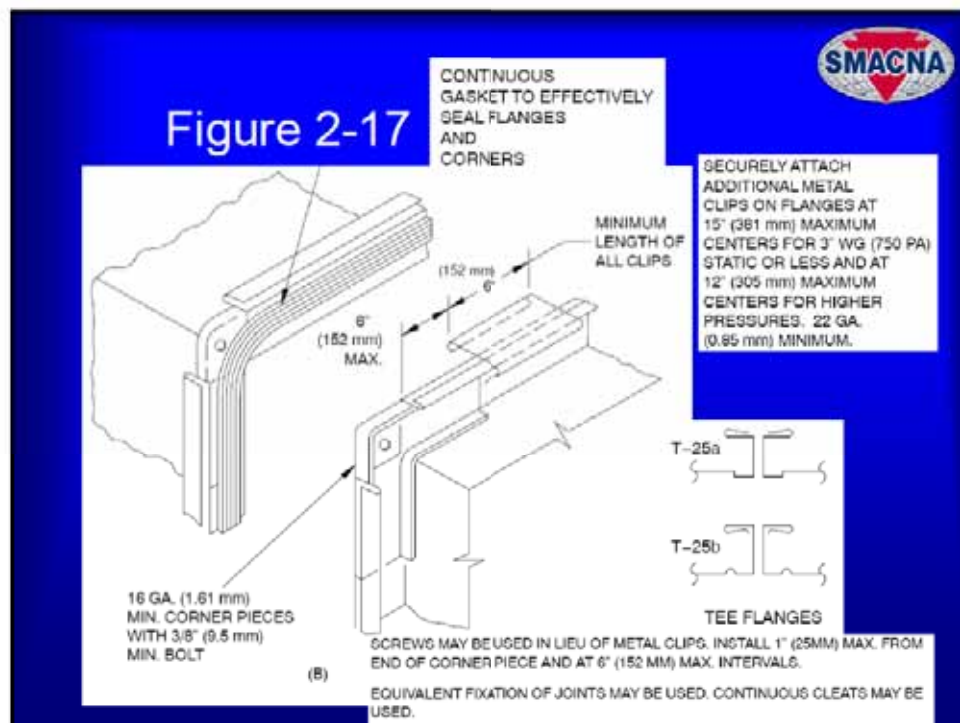
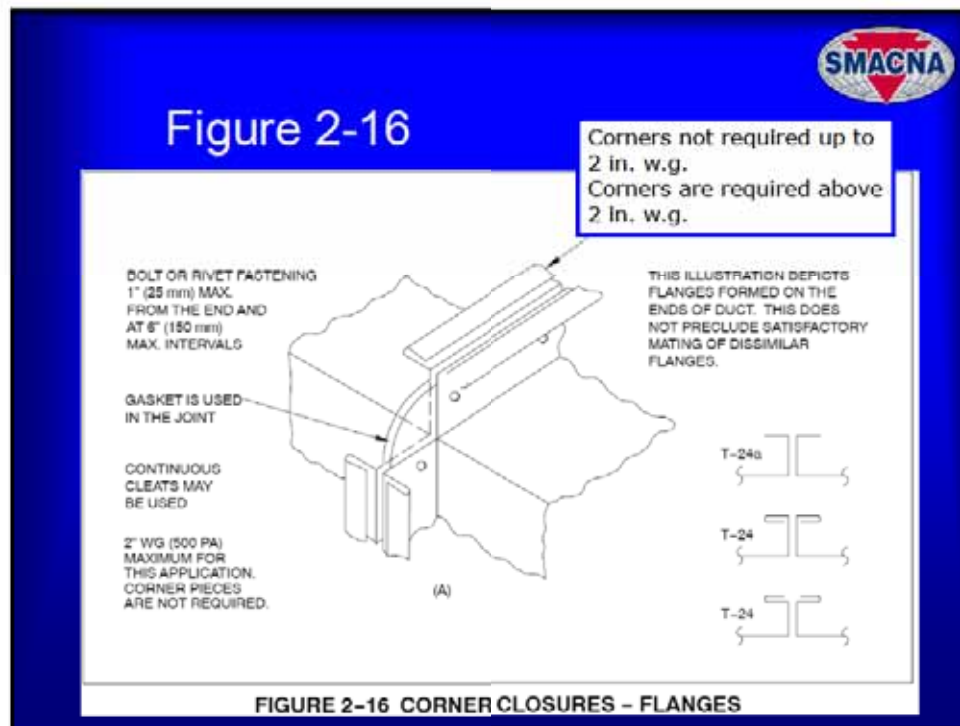



Longitudinal Seams



- Figure 2-17
- Page 2.10

Rectangular



Longitudinal Seams

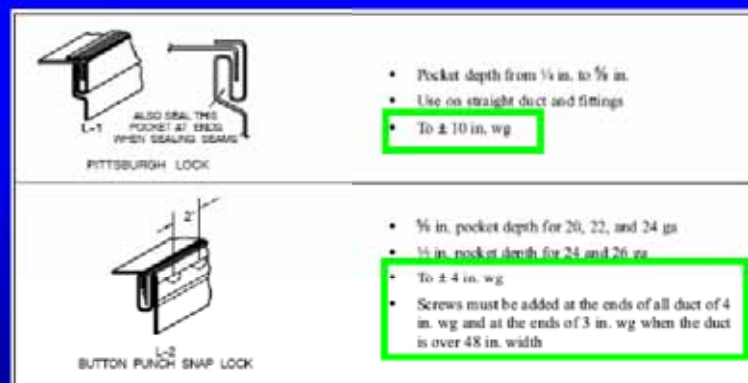



Longitudinal Seams



- To ± 10 in. wg



L-4 STANDING SEAM

- To ± 10 in. wg
- 1 in. seam up to duct width of 42 in.
- 1 ½ in. seam for larger ducts
- May be used on duct interiors
- Fasten at 2 in. maximum from ends and at 8 in. maximum intervals



Longitudinal Seams



- To ± 10 in. wg
- Fasten as per L-4



- Assemble per Figure 2-17
- Ratings may be adjusted with E1-rated bar stock or members from Tables 2-29 and 2-30
- Supplemental members may be attached to the duct wall on both sides of the joint
- Single members may be used if they are fastened through both mating flanges
- Gasket to be located to form an effective seal



Intermediate Reinforcement

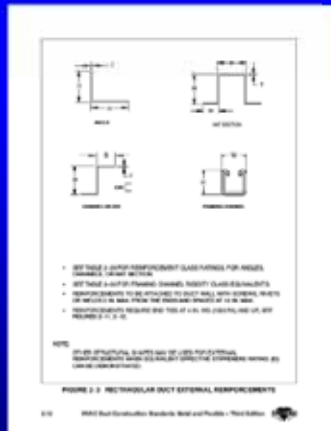

- Figure 2-3
- Page 2.12

Rectangular



Intermediate Reinforcement

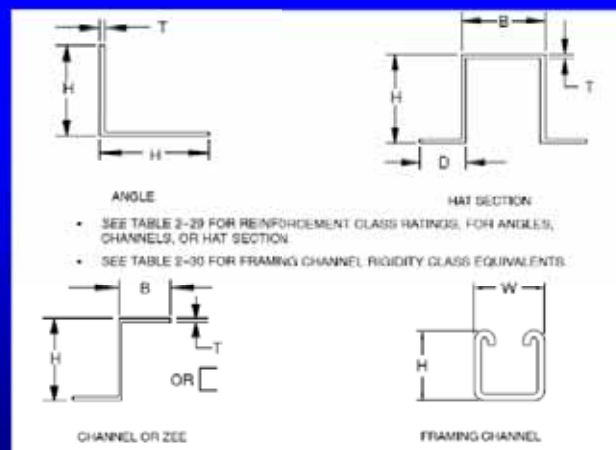



Basic Duct Construction Process

- Verify pressure class
- Check corresponding table
- Start with the larger side first
- Determine reinforcement spacing options
- Check joint reinforcement tables
- Check intermediate reinforcement tables if applicable (*tie rod options next webinar*)
- Repeat for the short side



Guide Summary (P 2.5)

The table provides reinforcement requirements for ducts based on pressure class and duct size. The columns include pressure class (e.g., 15, 20, 25, 30, 35, 40, 45, 50, 55, 60, 65, 70, 75, 80, 85, 90, 95, 100), duct size (e.g., 18, 20, 22, 24, 26, 28, 30, 32, 34, 36, 38, 40, 42, 44, 46, 48, 50, 52, 54, 56, 58, 60, 62, 64, 66, 68, 70, 72, 74, 76, 78, 80, 82, 84, 86, 88, 90, 92, 94, 96, 98, 100), and reinforcement details (e.g., reinforcement class, spacing, and tie rod requirements). A line graph is overlaid on the table, showing the relationship between duct size and reinforcement requirements. The table is titled 'Reinforcement Tables' and includes a note about the use of tie rods.

- Circles are column numbers
- Number in box is the minimum gage
- First letter is minimum reinforcement class required.
- Second letter is downsized reinforcement when used with tie rod
- Xt – t means tie rod is required



In Words...

- If the box in the table shows H-20G
- The minimum panel gage is 20
- The reinforcement required is class H at the spacing noted at the top of the column (this can be a joint or intermediate reinforcement)
- You can use G instead of H if you use a tie rod as well. (If to achieve a class G you are already required to use a tie rod then you can not use this option)



Rectangular Duct Reinforcement

2 in. wg Static Pos. or Neg.	No Reinforcement Required	Reinforcement Code for Duct Gage Number									
		Reinforcement Spacing Options									
		10 ft	4 ft	6 ft	8 ft	4 ft	3 ft	2 1/2 ft	2 ft		
Duct Dimension		①	②	③	④	⑤	⑥	⑦	⑧	⑨	⑩
10 in. and under	26 ga.	Not Required									
11 - 12 in.	26 ga.										
13 - 14 in.	24 ga.			B-26	B-26	B-26	B-26	B-26	B-26	B-26	B-26
15 - 16 in.	24 ga.			C-26	C-26	C-26	C-26	C-26	C-26	B-26	B-26
17 - 18 in.	22 ga.			C-26	C-26	C-26	C-26	C-26	C-26	C-26	B-26
19 - 20 in.	20 ga.	C-22	C-24	C-26	C-26	C-26	C-26	C-26	C-26	C-26	C-26
21 - 22 in.	18 ga.	D-22	D-24	D-26	D-26	C-26	C-26	C-26	C-26	C-26	C-26
23 - 24 in.	18 ga.	E-22	E-24	D-26	D-26	D-26	C-26	C-26	C-26	C-26	C-26
25 - 26 in.	18 ga.	E-22	E-22	E-24	D-26	D-26	C-26	C-26	C-26	C-26	C-26
27 - 28 in.	18 ga.	F-20	F-20	E-22	E-24	D-26	D-26	C-26	C-26	C-26	C-26
29 - 30 in.	18 ga.	F-20	F-20	E-22	E-24	E-26	D-26	D-26	D-26	C-26	C-26
31 - 36 in.	16 ga.	G-18	G-20	F-22	F-24	E-24	E-26	D-26	D-26	D-26	D-26
37 - 42 in.		H-16	H-18	G-20	G-22	F-24	E-24	E-26	E-26	E-26	E-26
43 - 48 in.			I-18	H-20	H-22	G-22	F-24	F-24	F-24	E-24	E-24
49 - 54 in.			I-16G	I-18G	H-20G	H-20G	G-24	F-24	F-24	F-24	F-24
55 - 60 in.				I-18G	I-20G	H-20G	G-22	G-24	F-24	F-24	F-24



Rectangular Duct Reinforcement

2 in. wg Static Pos. or Neg.	No Reinforcement Required	Reinforcement Code for Duct Gauge Number								
		Reinforcement Spacing Options								
		10 ft	3 ft	6 ft	5 ft	4 ft	3 ft	2 1/2 ft	2 ft	
①	②	③	④	⑤	⑥	⑦	⑧	⑨	⑩	
10 in. and under	26 ga.	Not Required								
11 - 12 in.	26 ga.									
13 - 14 in.	24 ga.		B-26	B-26	B-26	B-26	B-26	B-26	B-26	B-26
15 - 16 in.	24 ga.		C-26	C-26	C-26	C-26	C-26	C-26	C-26	C-26
17 - 18 in.	22 ga.		C-26	C-26	C-26	C-26	C-26	C-26	C-26	B-26
19 - 20 in.	20 ga.	C-22	C-24	C-26	C-26	C-26	C-26	C-26	C-26	C-26
21 - 22 in.	18 ga.	D-22	D-24	D-26	D-26	C-26	C-26	C-26	C-26	C-26
23 - 24 in.	18 ga.	E-22	E-24	D-26	D-26	D-26	C-26	C-26	C-26	C-26
25 - 26 in.	18 ga.	E-22	E-22	E-24	D-26	D-26	C-26	C-26	C-26	C-26
27 - 28 in.	18 ga.	F-20	E-20	E-22	E-24	D-26	D-26	C-26	C-26	C-26
29 - 30 in.	18 ga.	F-20	F-20	E-22	E-24	E-26	D-26	D-26	C-26	C-26
31 - 36 in.	16 ga.	G-18	G-20	F-22	F-24	E-24	E-26	D-26	D-26	D-26
37 - 42 in.		H-16	H-18	G-20	G-22	F-24	E-24	E-26	E-26	E-26
43 - 48 in.			I-18	H-20	H-22	G-22	F-24	F-24	E-24	E-24
49 - 54 in.			I-16G	I-18G	H-20G	H-20G	G-24	F-24	F-24	F-24
55 - 60 in.				I-18G	I-20G	H-20G	G-22	G-24	F-24	F-24



Rectangular Duct Reinforcement

2 in. wg Static Pos. or Neg.	No Reinforcement Required	Reinforcement Code for Duct Gauge Number								
		Reinforcement Spacing Options								
		10 ft	3 ft	6 ft	5 ft	4 ft	3 ft	2 1/2 ft	2 ft	
①	②	③	④	⑤	⑥	⑦	⑧	⑨	⑩	
10 in. and under	26 ga.	Not Required								
11 - 12 in.	26 ga.									
13 - 14 in.	24 ga.		B-26	B-26	B-26	B-26	B-26	B-26	B-26	B-26
15 - 16 in.	24 ga.		C-26	C-26	C-26	C-26	C-26	C-26	C-26	C-26
17 - 18 in.	22 ga.		C-26	C-26	C-26	C-26	C-26	C-26	C-26	B-26
19 - 20 in.	20 ga.	C-22	C-24	C-26	C-26	C-26	C-26	C-26	C-26	C-26
21 - 22 in.	18 ga.	D-22	D-24	D-26	D-26	C-26	C-26	C-26	C-26	C-26
23 - 24 in.	18 ga.	E-22	E-24	D-26	D-26	D-26	C-26	C-26	C-26	C-26
25 - 26 in.	18 ga.	E-22	E-22	E-24	D-26	D-26	C-26	C-26	C-26	C-26
27 - 28 in.	18 ga.	F-20	E-20	E-22	E-24	D-26	D-26	C-26	C-26	C-26
29 - 30 in.	18 ga.	F-20	F-20	E-22	E-24	E-26	D-26	D-26	C-26	C-26
31 - 36 in.	16 ga.	G-18	G-20	F-22	F-24	E-24	E-26	D-26	D-26	D-26
37 - 42 in.		H-16	H-18	G-20	G-22	F-24	E-24	E-26	E-26	E-26
43 - 48 in.			I-18	H-20	H-22	G-22	F-24	F-24	E-24	E-24
49 - 54 in.			I-16G	I-18G	H-20G	H-20G	G-24	F-24	F-24	F-24
55 - 60 in.				I-18G	I-20G	H-20G	G-22	G-24	F-24	F-24



Rectangular Duct Reinforcement

Duct Dimension ①	2 in. wg Static Pos. or Neg. ②	No Reinforcement Required	Reinforcement Code for Duct Gauge Number							
			Reinforcement Spacing Options							
			10 ft ③	8 ft ④	6 ft ⑤	5 ft ⑥	4 ft ⑦	3 ft ⑧	2 1/2 ft ⑨	2 ft ⑩
10 in. and under	26 ga.		Not Required							
11 - 12 in.	26 ga.									
13 - 14 in.	24 ga.		B-26	B-26	B-26	B-26	B-26	B-26	B-26	B-26
15 - 16 in.	24 ga.		C-26	C-26	C-26	C-26	C-26	C-26	C-26	C-26
17 - 18 in.	22 ga.		C-26	C-26	C-26	C-26	C-26	C-26	C-26	C-26
19 - 20 in.	20 ga.	C-22	C-24	C-26	C-26	C-26	C-26	C-26	C-26	C-26
21 - 22 in.	18 ga.	D-22	D-24	D-26	D-26	C-26	C-26	C-26	C-26	C-26
23 - 24 in.	18 ga.	E-22	E-24	D-26	D-26	D-26	C-26	C-26	C-26	C-26
25 - 26 in.	18 ga.	E-22	E-22	E-24	D-26	D-26	C-26	C-26	C-26	C-26
27 - 28 in.	18 ga.	F-20	E-20	E-22	E-24	D-26	D-26	C-26	C-26	C-26
29 - 30 in.	18 ga.	F-20	F-20	E-22	E-24	E-26	D-26	D-26	C-26	C-26
31 - 36 in.	16 ga.	G-18	G-20	F-22	F-24	E-24	E-26	D-26	D-26	D-26
37 - 42 in.		H-16	H-18	G-20	G-22	F-24	E-24	E-26	E-26	E-26
43 - 48 in.			I-18	H-20	H-22	G-22	F-24	F-24	E-24	E-24
49 - 54 in.			I-16G	I-18G	H-20G	H-20G	G-24	F-24	F-24	F-24
55 - 60 in.				I-18G	I-20G	H-20G	G-22	G-24	F-24	F-24



Rectangular Duct Reinforcement

Duct Dimension ①	2 in. wg Static Pos. or Neg. ②	No Reinforcement Required	Reinforcement Code for Duct Gauge Number							
			Reinforcement Spacing Options							
			10 ft ③	8 ft ④	6 ft ⑤	5 ft ⑥	4 ft ⑦	3 ft ⑧	2 1/2 ft ⑨	2 ft ⑩
10 in. and under	26 ga.		Not Required							
11 - 12 in.	26 ga.									
13 - 14 in.	24 ga.		B-26	B-26	B-26	B-26	B-26	B-26	B-26	B-26
15 - 16 in.	24 ga.		C-26	C-26	C-26	C-26	C-26	C-26	C-26	C-26
17 - 18 in.	22 ga.		C-26	C-26	C-26	C-26	C-26	C-26	C-26	C-26
19 - 20 in.	20 ga.	C-22	C-24	C-26	C-26	C-26	C-26	C-26	C-26	C-26
21 - 22 in.	18 ga.	D-22	D-24	D-26	D-26	C-26	C-26	C-26	C-26	C-26
23 - 24 in.	18 ga.	E-22	E-24	D-26	D-26	D-26	C-26	C-26	C-26	C-26
25 - 26 in.	18 ga.	E-22	E-22	E-24	D-26	D-26	C-26	C-26	C-26	C-26
27 - 28 in.	18 ga.	F-20	E-20	E-22	E-24	D-26	D-26	C-26	C-26	C-26
29 - 30 in.	18 ga.	F-20	F-20	E-22	E-24	E-26	D-26	D-26	C-26	C-26
31 - 36 in.	16 ga.	G-18	G-20	F-22	F-24	E-24	E-26	D-26	D-26	D-26
37 - 42 in.		H-16	H-18	G-20	G-22	F-24	E-24	E-26	E-26	E-26
43 - 48 in.			I-18	H-20	H-22	G-22	F-24	F-24	E-24	E-24
49 - 54 in.			I-16G	I-18G	H-20G	H-20G	G-24	F-24	F-24	F-24
55 - 60 in.				I-18G	I-20G	H-20G	G-22	G-24	F-24	F-24



Joint Reinforcement

- Table 2-31
- Starts on page 2.74
- Covers all transverse joints that qualify as reinforcement except T-1 drive slip
- For T-1 drive slip see Table 2-48 on page 2.110

Reinf. Class	T-2 Standing N		T-24 Standing N		T-1 Standing N		T-12 Standing N		T-14 Standing N	
	WT LF	WT LF	WT LF	WT LF	WT LF	WT LF	WT LF	WT LF	WT LF	WT LF
A	1.0	18 x 20 ga	0.4	18 x 20 ga	0.4	18 x 20 ga	0.4	18 x 20 ga	0.4	18 x 20 ga
B	1.0	18 x 20 ga	0.4	18 x 20 ga	0.4	18 x 20 ga	0.4	18 x 20 ga	0.4	18 x 20 ga
C	1.9	18 x 20 ga	0.4	18 x 20 ga	0.4	18 x 20 ga	0.4	18 x 20 ga	0.4	18 x 20 ga
D	2.7	18 x 20 ga	0.4	18 x 20 ga	0.4	18 x 20 ga	0.4	18 x 20 ga	0.4	18 x 20 ga
E	0.5	26 ga	0.4	18 x 20 ga	0.4	18 x 20 ga	0.4	18 x 20 ga	0.4	18 x 20 ga
F	1.0	18 x 20 ga	0.4	18 x 20 ga	0.4	18 x 20 ga	0.4	18 x 20 ga	0.4	18 x 20 ga
G	1.0	18 x 20 ga	0.4	18 x 20 ga	0.4	18 x 20 ga	0.4	18 x 20 ga	0.4	18 x 20 ga
H	1.0	18 x 20 ga	0.4	18 x 20 ga	0.4	18 x 20 ga	0.4	18 x 20 ga	0.4	18 x 20 ga
I	1.0	18 x 20 ga	0.4	18 x 20 ga	0.4	18 x 20 ga	0.4	18 x 20 ga	0.4	18 x 20 ga
J	1.0	18 x 20 ga	0.4	18 x 20 ga	0.4	18 x 20 ga	0.4	18 x 20 ga	0.4	18 x 20 ga
K	1.0	18 x 20 ga	0.4	18 x 20 ga	0.4	18 x 20 ga	0.4	18 x 20 ga	0.4	18 x 20 ga
L	1.0	18 x 20 ga	0.4	18 x 20 ga	0.4	18 x 20 ga	0.4	18 x 20 ga	0.4	18 x 20 ga
M	1.0	18 x 20 ga	0.4	18 x 20 ga	0.4	18 x 20 ga	0.4	18 x 20 ga	0.4	18 x 20 ga
N	1.0	18 x 20 ga	0.4	18 x 20 ga	0.4	18 x 20 ga	0.4	18 x 20 ga	0.4	18 x 20 ga
O	1.0	18 x 20 ga	0.4	18 x 20 ga	0.4	18 x 20 ga	0.4	18 x 20 ga	0.4	18 x 20 ga
P	1.0	18 x 20 ga	0.4	18 x 20 ga	0.4	18 x 20 ga	0.4	18 x 20 ga	0.4	18 x 20 ga
Q	1.0	18 x 20 ga	0.4	18 x 20 ga	0.4	18 x 20 ga	0.4	18 x 20 ga	0.4	18 x 20 ga
R	1.0	18 x 20 ga	0.4	18 x 20 ga	0.4	18 x 20 ga	0.4	18 x 20 ga	0.4	18 x 20 ga
S	1.0	18 x 20 ga	0.4	18 x 20 ga	0.4	18 x 20 ga	0.4	18 x 20 ga	0.4	18 x 20 ga
T	1.0	18 x 20 ga	0.4	18 x 20 ga	0.4	18 x 20 ga	0.4	18 x 20 ga	0.4	18 x 20 ga
U	1.0	18 x 20 ga	0.4	18 x 20 ga	0.4	18 x 20 ga	0.4	18 x 20 ga	0.4	18 x 20 ga
V	1.0	18 x 20 ga	0.4	18 x 20 ga	0.4	18 x 20 ga	0.4	18 x 20 ga	0.4	18 x 20 ga
W	1.0	18 x 20 ga	0.4	18 x 20 ga	0.4	18 x 20 ga	0.4	18 x 20 ga	0.4	18 x 20 ga
X	1.0	18 x 20 ga	0.4	18 x 20 ga	0.4	18 x 20 ga	0.4	18 x 20 ga	0.4	18 x 20 ga
Y	1.0	18 x 20 ga	0.4	18 x 20 ga	0.4	18 x 20 ga	0.4	18 x 20 ga	0.4	18 x 20 ga
Z	1.0	18 x 20 ga	0.4	18 x 20 ga	0.4	18 x 20 ga	0.4	18 x 20 ga	0.4	18 x 20 ga

Table 2-31: Transverse Joint Reinforcement
 For Section 2.1.4, *Minimum 1/2 in. maximum flange thickness. **Antenna adjustment for loading measurement. T-1 and T-12 through T-14 are restricted to 30 in. length of slip, up to 30 in. length of T in slip and are not recommended for service above 4 in. w.g. (1) conditions practice provisions may apply.







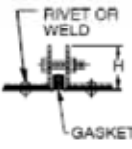

Joint Reinforcement

Reinf. Class	E1*	T-22 Companion Angles		T-24 Flanged		T-24a Flanged		T-25b Flanged	
		H x T	WT LF	T (Nom.)	WT LF	H x T (Nom.)	WT LF	H x T (Nom.)	WT LF
B	1.0	Use E		Use D		Use D		Use D	
C	1.9	Use E		Use D		Use D		Use D	
D	2.7	Use E		26 ga	0.5	1 x 22 ga	0.4	26 ga	0.5

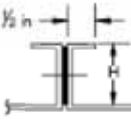

Joint Reinforcement

Rein. Class						
	T-22 Companion Angles	T-24 Flanged	T-24a Flanged	T-25a Flanged	T-25b Flanged	Slip-On Flange
I	69	$1\frac{1}{2} \times \frac{1}{4}$	3.7	20 ga (R)	1.0	4.7
J	80	$1\frac{1}{2} \times \frac{1}{4} (+)$ $2 \times \frac{1}{8}$	4.7	18 ga (R)	1.1	SEE TIE ROD TEXT

The (R) means use with a tie rod

The (+) means use for positive pressure application only



Table 2-48

Duct Wall	26 ga		24 ga		22 ga		20 ga or Heavier	
	Maximum Duct Width (W) and Maximum Reinforcement Spacing (RS)							
Static Pressure	W	RS	W	RS	W	RS	W	RS
$\frac{1}{2}$ in. wg	20 in. 18 in.	10 ft N.R.	20 in.	N.R.	20 in.	N.R.	20 in.	N.R.
1 in. wg	20 in. 14 in. 12 in.	8 ft 10 ft N.R.	20 in. 14 in.	8 ft N.R.	20 in. 18 in.	10 ft N.R.	20 in.	N.R.
2 in. wg	18 in.	5 ft	18 in. 12 in.	8 ft N.R.	18 in. 14 in.	10 ft N.R.	18 in.	N.R.
3 in. wg	12 in. 10 in.	5 ft 6 ft	18 in. 10 in.	5 ft N.R.	18 in. 12 in.	5 ft N.R.	18 in. 14 in.	6 ft N.R.
4 in. wg	Not Accepted		16 in. 8 in.	5 ft N.R.	12 in. 8 in.	6 ft N.R.	12 in.	N.R.

Table 2-48 T-1 Flat Drive Accepted as Reinforcement



Example 1

- Pressure class is positive 1/2 in. w.g.
- Dimensions are 20 in. x 12 in.
- 5 ft. joint spacing (longer if possible)
- Preferred joint type plain Slip and Drive



Example 1

½ in. wg Static Pos. or Neg.	No Reinforcement Required	Reinforcement Code for Duct Gage Number							
		Reinforcement Spacing Options							
Duct Dimension		10 ft	8 ft	6 ft	5 ft	4 ft	3 ft	2½ ft	2 ft
①	②	③	④	⑤	⑥	⑦	⑧	⑨	⑩
10 in. and under	26 ga.	Not Required							
11 – 12 in.	26 ga.								
13 – 14 in.	26 ga.								
15 – 16 in.	26 ga.								
17 – 18 in.	26 ga.								
19 – 20 in.	24 ga.	B-26	B-26	B-26	B-26	B-26	B-26	A-26	A-26
21 – 22 in.	22 ga.	B-26	B-26	B-26	B-26	B-26	B-26	B-26	A-26

Page
2.14



Example 1 Table 2-48

Duct Wall	26 ga		24 ga		22 ga		20 ga or Heavier	
	Maximum Duct Width (W) and Maximum Reinforcement Spacing (RS)							
Static Pressure	W	RS	W	RS	W	RS	W	RS
½ in. wg	20 in. 18 in.	10 ft N.R.	20 in.	N.R.	20 in.	N.R.	20 in.	N.R.
1 in. wg	20 in. 14 in. 12 in.	8 ft 10 ft N.R.	20 in. 14 in.	8 ft N.R.	20 in. 18 in.	10 ft N.R.	20 in.	N.R.
2 in. wg	18 in.	5 ft	18 in. 12 in.	8 ft N.R.	18 in. 14 in.	10 ft N.R.	18 in.	N.R.
3 in. wg	12 in. 10 in.	5 ft 6 ft	18 in. 10 in.	5 ft N.R.	18 in. 12 in.	5 ft N.R.	18 in. 14 in.	6 ft N.R.
4 in. wg	Not Accepted		16 in. 8 in.	5 ft N.R.	12 in. 8 in.	6 ft N.R.	12 in.	N.R.

Page
2.110

Table 2-48 T-1 Flat Drive Accepted as Reinforcement

Although the flat drive slip T-1 does not satisfy the EI calculation requirements for Classes A, B or C reinforcement, tests predict its suitability for use as reinforcement within the limits of the table.

N.R. – No reinforcement is required; however, the T-1 Joint may be used.



Example 1 Solutions

- Option 1
 - Use 24 gage
 - No reinforcement required either side
- Option 2
 - Use 26 gage
 - T-1 (plain drive) on the 20 in. side at a max spacing of 10 ft
 - No reinforcement required on the 12 in. side



Intermediate Reinforcement

- Table 2-29
- Starts on page 2.70
- Covers typical intermediate reinforcement types.
- For struts see Table 2-30 on page 2.72

Reinf. Class	Angle		Channel or Zee		Hat Section		
	EI*	H x T (MIN)	WT	H x B x T (MIN)	WT	H x B x D x T (MIN)	
A	0.43	Use C		Use B		Use F	
B	1.0	Use C		3/4 x 1/2 x 20 ga	0.24	Use F	
C	1.9	C 1 x 16 ga C 3/4 x 1/2	0.40 0.57	3/4 x 1/2 x 18 ga 1 x 3/4 x 20 ga	0.31	Use F	
D	2.7	H 3/4 x 1/2 C 1 x 1/2	0.57 0.80	1 x 3/4 x 18 ga	0.45	Use F	
E	6.5	C 1 1/4 x 12 ga H 1 x 1/2	0.90	2 x 1 1/4 x 20 ga	0.60	Use F	
F	12.8	H 1 1/4 x 1/2	1.02	1 1/2 x 3/4 x 18 ga	0.54	1 1/2 x 3/4 x 3/4 x 18 ga 1 1/2 x 1 1/2 x 3/4 x 20 ga	0.90 0.83

Table 2-29 Intermediate Reinforcement



Intermediate Reinforcement

Reinf. Class	Angle		Channel or Zee		Hat Section		
	EI*	H x T (MIN)	WT	H x B x T (MIN)	WT	H x B x D x T (MIN)	
A	0.43	Use C		Use B		Use F	
B	1.0	Use C		3/4 x 1/2 x 20 ga	0.24	Use F	
C	1.9	C 1 x 16 ga C 3/4 x 1/2	0.40 0.57	3/4 x 1/2 x 18 ga 1 x 3/4 x 20 ga	0.31	Use F	
D	2.7	H 3/4 x 1/2 C 1 x 1/2	0.57 0.80	1 x 3/4 x 18 ga	0.45	Use F	
E	6.5	C 1 1/4 x 12 ga H 1 x 1/2	0.90	2 x 1 1/4 x 20 ga	0.60	Use F	
F	12.8	H 1 1/4 x 1/2	1.02	1 1/2 x 3/4 x 18 ga	0.54	1 1/2 x 3/4 x 3/4 x 18 ga 1 1/2 x 1 1/2 x 3/4 x 20 ga	0.90 0.83



Intermediate Reinforcement

Reinf. Class	Angle		Channel or Zee		Hat Section		
	EI*	H x T (MIN)	WT LF	H x B x T (MIN)	WT LF	H x B x D x T (MIN)	WT LF
A	0.43	Use C		Use B		Use F	
B	1.0	Use C		3/4 x 3/4 x 20 ga	0.24	Use F	
C	1.9	C 1 x 16 ga	0.40	H denotes Hot formed C denotes Cold formed			
		C 3/4 x 3/4	0.57				
D	2.7	H 3/4 x 3/4	0.57				
		C 1 x 3/4	0.80				
E	6.5	C 1 3/4 x 12 ga H 1 x 3/4	0.90	2 x 1 3/4 x 20 ga	0.60	Use F	
F	12.8	H 1 3/4 x 3/4	1.02	1 1/2 x 3/4 x 18 ga	0.54	1 1/2 x 3/4 x 3/4 x 18 ga	0.90
						1 1/2 x 1 1/2 x 3/4 x 20 ga	0.83



Example 2

- Pressure Class is 2 in. w.g.
- Dimensions are 60 in. x 26 in.
- 5 foot joint spacing
- TDC or TDF joint
- No internal reinforcement



The Right Table (Pressure Class)

Page 2.18

Duct Dimension ①	2 in. wg Static Pos. or Neg. ②	No Reinforcement Required	Reinforcement Code for Duct Gauge Number							
			Reinforcement Spacing Options							
			10 ft	3 ft	6 ft	5 ft	4 ft	3 ft	2 1/2 ft	2 ft
③	④	⑤	⑥	⑦	⑧	⑨	⑩			
10 in. and under	26 ga.		Not Required							
11 - 12 in.	26 ga.									
13 - 14 in.	24 ga.			B-26	B-26	B-26	B-26	B-26	B-26	
15 - 16 in.	24 ga.			C-26	C-26	C-26	C-26	C-26	B-26	
17 - 18 in.	22 ga.			C-26	C-26	C-26	C-26	C-26	B-26	
19 - 20 in.	20 ga.	C-22	C-24	C-26	C-26	C-26	C-26	C-26	C-26	
21 - 22 in.	18 ga.	D-22	D-24	D-26	D-26	C-26	C-26	C-26	C-26	
23 - 24 in.	18 ga.	E-22	E-24	D-26	D-26	D-26	C-26	C-26	C-26	
25 - 26 in.	18 ga.	E-22	E-22	E-24	D-26	D-26	C-26	C-26	C-26	
27 - 28 in.	18 ga.	F-20	F-20	E-22	E-24	D-26	D-26	C-26	C-26	
29 - 30 in.	18 ga.	F-20	F-20	E-22	E-24	E-26	D-26	D-26	C-26	
31 - 36 in.	16 ga.	G-18	G-20	F-22	F-24	E-24	E-26	D-26	D-26	
37 - 42 in.		H-16	H-18	G-20	G-22	F-24	E-24	E-26	E-26	
43 - 48 in.			I-18	H-20	H-22	G-22	F-24	F-24	E-24	
49 - 54 in.			I-16G	I-18G	H-20G	H-20G	G-24	F-24	F-24	
55 - 60 in.				I-18G	I-20G	H-20G	G-22	G-24	F-24	



The Right Table (Pressure Class)

Page 2.18

Duct Dimension ①	2 in. wg Static Pos. or Neg. ②	No Reinforcement Required	Reinforcement Code for Duct Gauge Number							
			Reinforcement Spacing Options							
			10 ft	3 ft	6 ft	5 ft	4 ft	3 ft	2 1/2 ft	2 ft
③	④	⑤	⑥	⑦	⑧	⑨	⑩			
10 in. and under	26 ga.		Not Required							
11 - 12 in.	26 ga.									
13 - 14 in.	24 ga.			B-26	B-26	B-26	B-26	B-26	B-26	
15 - 16 in.	24 ga.			C-26	C-26	C-26	C-26	C-26	B-26	
17 - 18 in.	22 ga.			C-26	C-26	C-26	C-26	C-26	B-26	
19 - 20 in.	20 ga.	C-22	C-24	C-26	C-26	C-26	C-26	C-26	C-26	
21 - 22 in.	18 ga.	D-22	D-24	D-26	D-26	C-26	C-26	C-26	C-26	
23 - 24 in.	18 ga.	E-22	E-24	D-26	D-26	D-26	C-26	C-26	C-26	
25 - 26 in.	18 ga.	E-22	E-22	E-24	D-26	D-26	C-26	C-26	C-26	
27 - 28 in.	18 ga.	F-20	F-20	E-22	E-24	D-26	D-26	C-26	C-26	
29 - 30 in.	18 ga.	F-20	F-20	E-22	E-24	E-26	D-26	D-26	C-26	
31 - 36 in.	16 ga.	G-18	G-20	F-22	F-24	E-24	E-26	D-26	D-26	
37 - 42 in.		H-16	H-18	G-20	G-22	F-24	E-24	E-26	E-26	
43 - 48 in.			I-18	H-20	H-22	G-22	F-24	F-24	E-24	
49 - 54 in.			I-16G	I-18G	H-20G	H-20G	G-24	F-24	F-24	
55 - 60 in.				I-18G	I-20G	H-20G	G-22	G-24	F-24	



The Right Table (Pressure Class)

Page 2.18

Duct Dimension ①	2 in. wg Static Pos. or Neg. ②	No Reinforcement Required	Reinforcement Code for Duct Gauge Number							
			Reinforcement Spacing Options							
			10 ft	8 ft	6 ft	5 ft	4 ft	3 ft	2½ ft	2 ft
③	④	⑤	⑥	⑦	⑧	⑨	⑩			
10 in. and under	26 ga.		Not Required							
11 – 12 in.	26 ga.									
13 – 14 in.	24 ga.			B-26	B-26	B-26	B-26	B-26	B-26	B-26
15 – 16 in.	24 ga.			C-26	C-26	C-26	C-26	C-26	C-26	B-26
17 – 18 in.	22 ga.			C-26	C-26	C-26	C-26	C-26	C-26	B-26
19 – 20 in.	20 ga.	C-22	C-24	C-26	C-26	C-26	C-26	C-26	C-26	C-26
21 – 22 in.	18 ga.	D-22	D-24	D-26	D-26	C-26	C-26	C-26	C-26	C-26
23 – 24 in.	18 ga.	E-22	E-24	D-26	D-26	D-26	C-26	C-26	C-26	C-26
25 – 26 in.	18 ga.	E-22	E-22	E-24	D-26	D-26	C-26	C-26	C-26	C-26
27 – 28 in.	18 ga.	F-20	E-20	E-22	E-24	D-26	D-26	C-26	C-26	C-26
29 – 30 in.	18 ga.	F-20	F-20	E-22	E-24	E-26	D-26	D-26	C-26	C-26
31 – 36 in.	16 ga.	G-18	G-20	F-22	F-24	E-24	E-26	D-26	D-26	D-26
37 – 42 in.		H-16	H-18	G-20	G-22	F-24	E-24	E-26	E-26	E-26
43 – 48 in.			I-18	H-20	H-22	G-22	F-24	F-24	E-24	E-24
49 – 54 in.			I-16G	I-18G	H-20G	I-20G	G-24	E-24	F-24	F-24
55 – 60 in.				I-18G	I-20G	I-20G	G-22	G-24	F-24	F-24

Joint Reinforcement

Page 2.76

Reinf. Class	EI*	H x T	WT LF	T-22 Companion Angles		T-24 Flanged		T-24a Flanged		T-25a Flanged		T-25b Flanged	
				T (Nom.)	WT LF	H x T (Nom.)	WT LF	H x T (Nom.)	WT LF	H x T (Nom.)	WT LF		
B	1.0	Use E		Use D		Use D		Use D		Use D		Use D	
C	1.9	Use E		Use D		Use D		Use D		Use D		Use D	
D	2.7	Use E	26 ga.	0.5	1 x 22 ga.	0.4	26 ga.	0.5					
E	6.5	C 1 x 3/8	1.7	24 ga.	0.6	Use F	24 ga.	0.6					
F	12.8	H 1 x 3/8	1.7	22 ga.	0.7	1 1/2 x 20 ga.	0.6	22 ga.	0.7				
G	15.8	1 1/8 x 3/8	2.1	22 ga (R) 20 G	1.0	1 1/2 x 18 ga.	0.8	22 ga (R) 20 ga	1.0				
H	26.4	C 1 1/2 x 3/8 (+) H 1 1/2 x 3/8	2.6	18 ga.	1.1			18 ga.	1.1				
I	69	1 1/2 x 3/4	3.7	20 ga (R)	1.0			20 ga (R)	1.0				



Joint Reinforcement

Page 2.76

Reinf. Class	T-22 Companion Angles			T-24 Flanged		T-24a Flanged		T-25a Flanged		T-25b Flanged	
	EI*	H x T	WT LF	T (Nom.)	WT LF	H x T (Nom.)	WT LF	H x T (Nom.)	WT LF	H x T (Nom.)	WT LF
B	1.0	Use E		Use D		Use D		Use D		Use D	
C	1.9	Use E		Use D		Use D		Use D		Use D	
D	2.7	Use E		26 ga	0.5	1 x 22 ga	0.4	26 ga	0.5		
E	6.5	C 1 x 3/8	1.7	24 ga	0.6	Use F		24 ga	0.6		
F	12.8	H 1 x 3/8	1.7	22 ga	0.7	1 1/2 x 20 ga	0.6	22 ga	0.7		
G	15.8	1 1/2 x 3/8	2.1	22 ga (R) 20 G	1.0	1 1/2 x 18 ga	0.8	22 ga (R) 20 ga	1.0		
H	26.4	C 1 1/2 x 3/8 (+) H 1 1/2 x 3/8	2.6	18 ga	1.1			18 ga	1.1		
I	69	1 1/2 x 3/8	3.7	20 ga (R)	1.0			20 ga (R)	1.0		

Intermediate Reinforcement

Page 2.70

Reinf. Class	Angle			Channel or Zee		Hat Section	
	EI*	H x T (MIN)	WT LF	E x B x T (MIN)	WT LF	H x B x D x T (MIN)	WT LF
A	0.43	Use C		Use B		Use F	
B	1.0	Use C		3/8 x 1/2 x 20 ga	0.24	Use F	
C	1.9	C 1 x 16 ga C 3/4 x 3/8	0.40 0.57	3/8 x 1/2 x 18 ga 1 x 3/8 x 20 ga	0.31	Use F	
D	2.7	H 3/4 x 3/8 C 1 x 3/8	0.57 0.80	1 x 3/8 x 18 ga	0.45	Use F	
E	6.5	C 1 1/4 x 12 ga H 1 x 3/8	0.90	2 x 1 1/2 x 20 ga	0.60	Use F	
F	12.8	H 1 1/4 x 3/8	1.02	1 1/2 x 3/8 x 18 ga	0.54	1 1/2 x 3/8 x 3/8 x 18 ga 1 1/2 x 1 1/2 x 3/8 x 20 ga	0.90 0.83
G	15.8	1 1/2 x 3/8	1.23	1 1/2 x 3/8 x 16 ga	0.66	1 1/2 x 3/8 x 3/8 x 18 ga	0.80
H	26.4	1 1/2 x 3/8	1.78	1 1/2 x 3/8 x 18 ga	0.83	1 1/2 x 1 1/2 x 3/8 x 18 ga	1.08



Intermediate Reinforcement

Reinf. Class	Angle			Channel or Zee		Hat Section	
	EI*	H x T (MIN)	WT LF	E x B x T (MIN)	WT LF	H x B x D x T (MIN)	WT LF
A	0.43	Use C		Use B		Use F	
B	1.0	Use C		3/4 x 3/4 x 20 ga	0.24	Use F	
C	1.9	C 1 x 16 ga C 3/4 x 3/4	0.40 0.57	3/4 x 1/2 x 18 ga 1 x 3/4 x 20 ga	0.31	Use F	
D	2.7	H 3/4 x 3/4 C 1 x 3/4	0.57 0.80	1 x 3/4 x 18 ga	0.45	Use F	
E	6.5	C 1 1/4 x 12 ga H 1 x 3/4	0.90	2 x 1 1/4 x 20 ga	0.60	Use F	
F	12.8	H 1 1/4 x 3/4	1.02	1 1/2 x 3/4 x 18 ga	0.54	1 1/2 x 3/4 x 3/4 x 18 ga 1 1/2 x 1 1/2 x 3/4 x 20 ga	0.90 0.83
G	15.8	1 1/2 x 3/4	1.23	1 1/2 x 3/4 x 16 ga	0.66	1 1/2 x 3/4 x 3/4 x 18 ga	0.80
H	22.2	1 1/2 x 7/8	1.78	1 1/2 x 7/8 x 16 ga	0.90	1 1/2 x 1 1/2 x 3/4 x 18 ga	1.08

Page 2.70



Intermediate Reinforcement

Channel (Strut)			Reinforcement Class Per Table 2-29
H	W	GA	
5/8 in.	5/8 in.	19	A, B, C
5/8 in.	1 1/8 in.	14	D
7/8 in.	1 1/8 in.	12	D, E
1 1/8 in.	1 1/8 in.	12	F, G
2 7/8 in.	1 7/8 in.	12	H, I, J
3 3/4 in.	1 3/4 in.	12	K, L

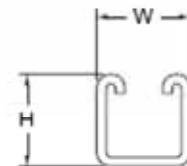

Table 2-30 Framing Channel



The Right Table (Pressure Class)

Page 2.18

Duct Dimension ①	2 in. wg Static Pos. or Neg. ②	No Reinforcement Required	Reinforcement Code for Duct Gauge Number							
			Reinforcement Spacing Options							
			10 ft	8 ft	6 ft	5 ft	4 ft	3 ft	2½ ft	2 ft
③	④	⑤	⑥	⑦	⑧	⑨	⑩			
10 in. and under	26 ga.		Not Required							
11 - 12 in.	26 ga.									
13 - 14 in.	24 ga.		B-26	B-26	B-26	B-26	B-26	B-26	B-26	B-26
15 - 16 in.	24 ga.		C-26	C-26	C-26	C-26	C-26	C-26	B-26	B-26
17 - 18 in.	22 ga.		C-26	C-26	C-26	C-26	C-26	C-26	C-26	B-26
19 - 20 in.	20 ga.	C-22	C-24	C-26	C-26	C-26	C-26	C-26	C-26	C-26
21 - 22 in.	18 ga.	D-22	D-24	D-26	D-26	C-26	C-26	C-26	C-26	C-26
23 - 24 in.	18 ga.	E-22	E-24	D-26	D-26	D-26	C-26	C-26	C-26	C-26
25 - 26 in.	18 ga.	E-22	F-22	E-24	D-26	D-26	C-26	C-26	C-26	C-26
27 - 28 in.	18 ga.	F-20	E-20	E-22	E-24	D-26	D-26	D-26	C-26	C-26
29 - 30 in.	18 ga.	F-20	F-20	E-22	E-24	E-26	D-26	D-26	C-26	C-26
31 - 36 in.	16 ga.	G-18	G-20	F-22	F-24	E-24	E-26	D-26	D-26	D-26
37 - 42 in.		H-16	H-18	G-20	G-22	F-24	E-24	E-26	E-26	E-26
43 - 48 in.			I-18	H-20	H-22	G-22	F-24	F-24	E-24	E-24
49 - 54 in.			J-16G	I-18G	H-20G	I-20G	G-24	F-24	F-24	F-24
55 - 60 in.				I-18G	I-20G	I-20G	G-22	G-24	F-24	F-24

Joint Reinforcement

Page 2.76

Reinf. Class	T-22 Companion Angles		T-24 Flanged		T-24a Flanged		T-25b Flanged		
	E1*	H x T	WT LF	T (Nom.)	WT LF	H x T (Nom.)	WT LF	H x T (Nom.)	WT LF
B	1.0	Use E		Use D		Use D		Use D	
C	1.9	Use E		Use D		Use D		Use D	
D	2.6	Use E		26 ga	0.6	1½ x 20 ga	0.6	26 ga	0.5
E	6.5	C 1 x ½	1.7	24 ga	0.6	Use F		24 ga	0.6
F	12.8	H 1 x ½	1.7	22 ga	0.7	1½ x 20 ga	0.6	22 ga	0.7
G	15.8	1¼ x ½	2.1	22 ga (R) 20 G	1.0	1½ x 18 ga	0.8	22 ga (R) 20 ga	1.0
H	26.4	C 1½ x ½ (+) H 1½ x ½	2.6	18 ga	1.1			18 ga	1.1
I	69	1½ x ¾	3.7	20 ga (R)	1.0			20 ga (R)	1.0



Example 2 Solution

- Duct gage is 20
- Joint spacing is 5 feet (56 ¼ in.)
- TDC/TDF for transverse joint
- Intermediate reinforcement (2 ½ feet)
 - G class
 - Angle 1 ½ x 1 ½ x 1/8
 - Not required on the 26 in. side



Intermediate External Reinforcement

- Reinforcement Intervals do not need to coincide
- At 4 in. positive pressure and above reinforcements must be tied
- Must be fastened to the duct within 2 in. from the corner (unless tied)
- Maximum fastener spacing is 12 in.

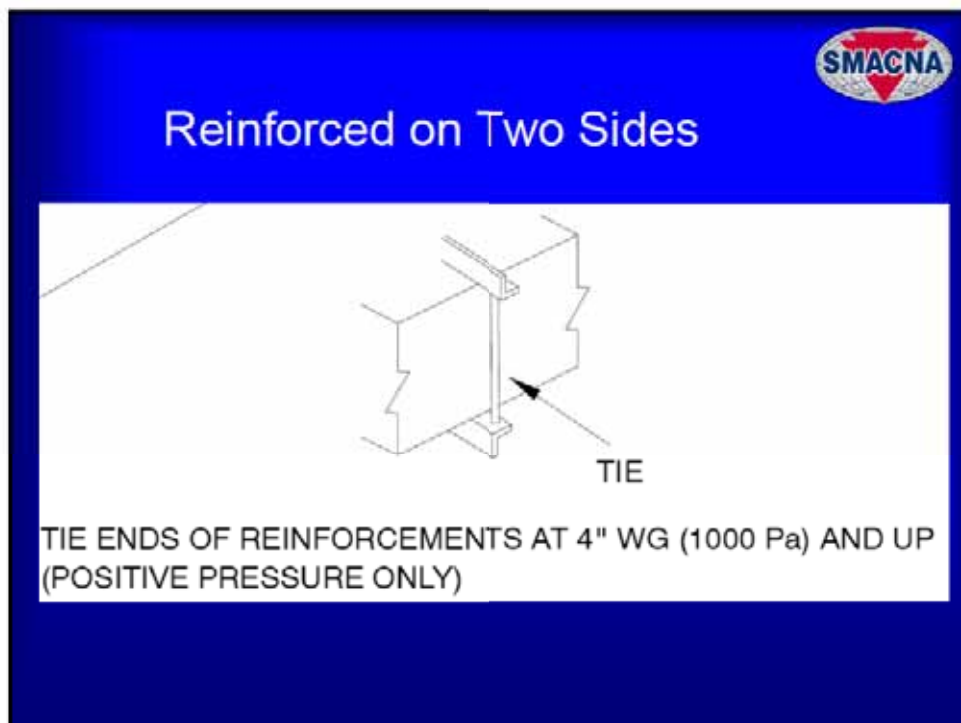
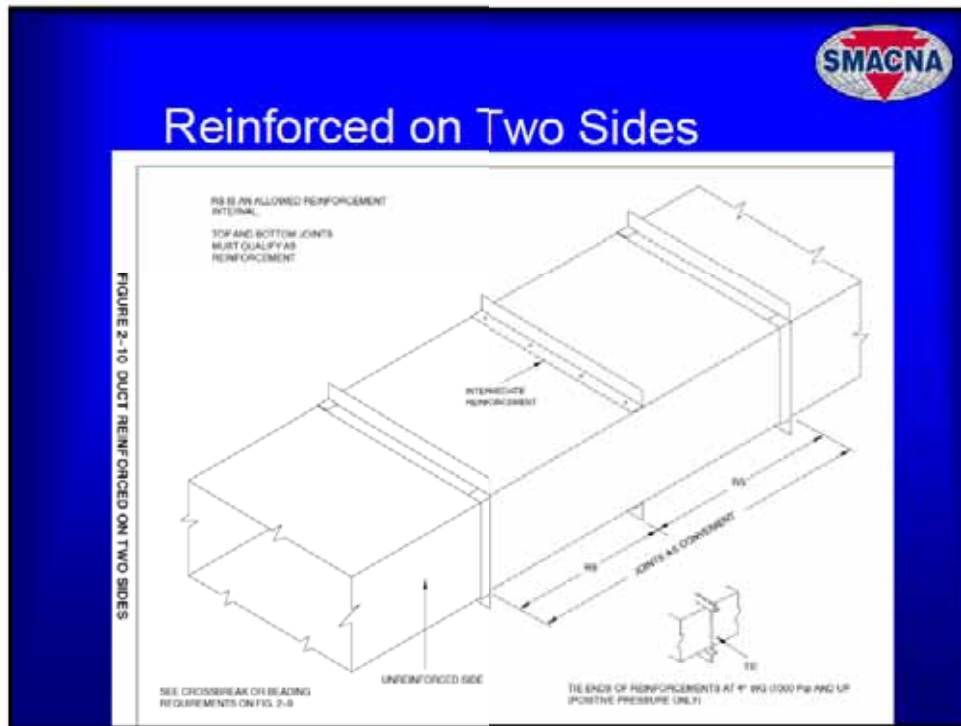



Reinforced on Four Sides

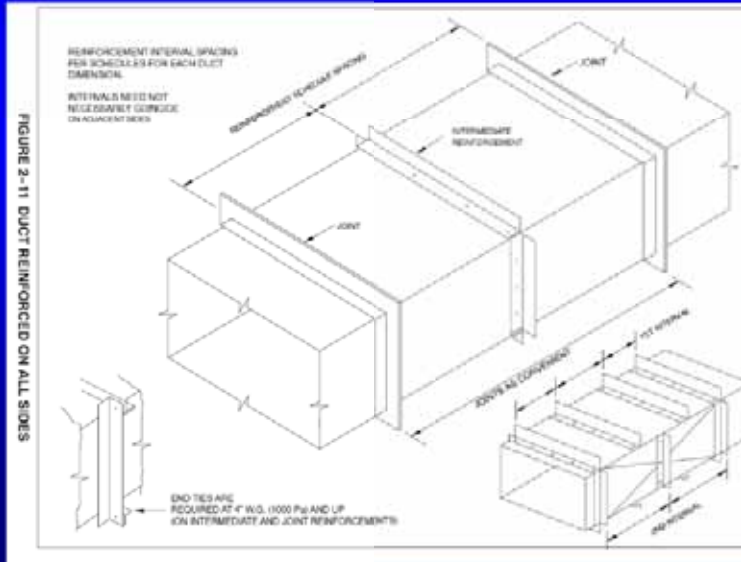
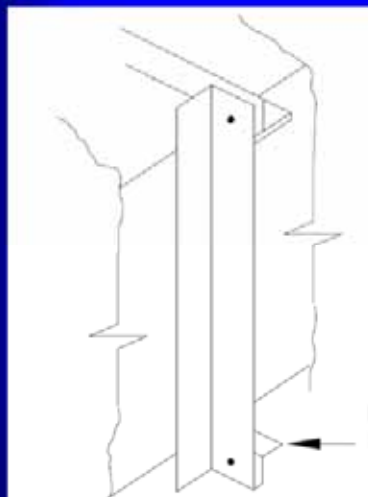

FIGURE 2-11 DUCT REINFORCED ON ALL SIDES



Reinforced on Four Sides



END TIES ARE
REQUIRED AT 4" W.G. (1000 Pa) AND UP
(ON INTERMEDIATE AND JOINT REINFORCEMENTS)



Reinforced on Four Sides

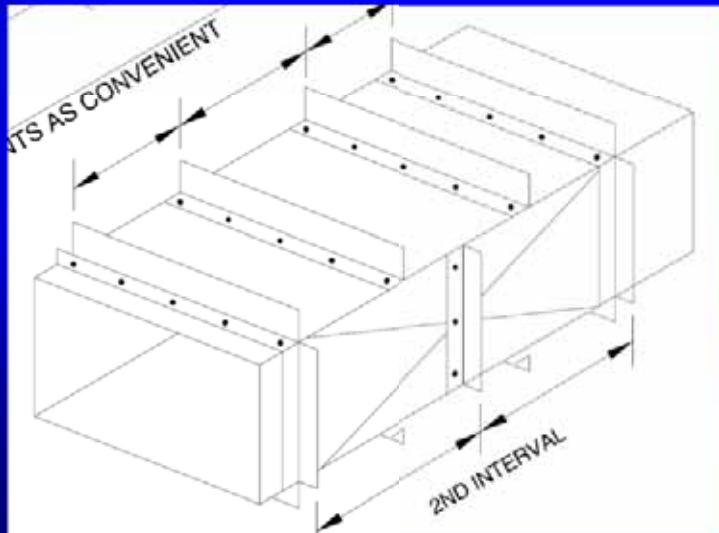

Reinforcement Attachment

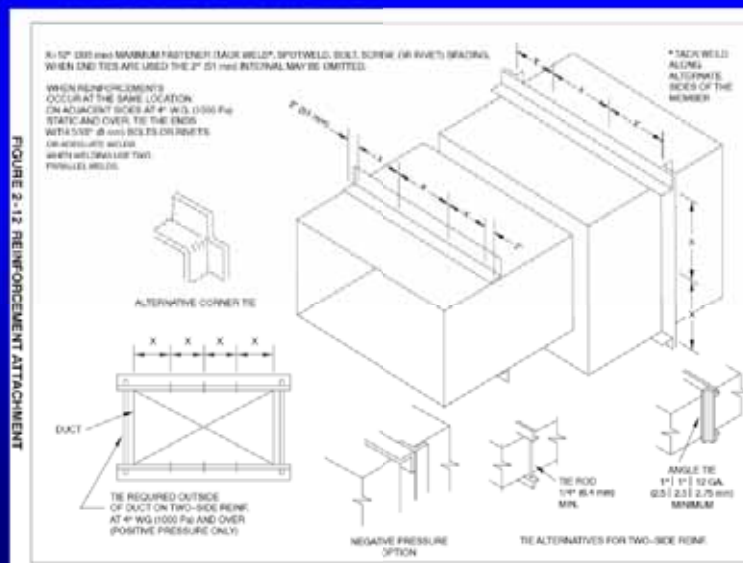



EI Ratings



FLANGED
(WITH GASKET)
T-25a







FLANGED
(WITH GASKET)
T-25b

- Assemble per Figure 2-17
- Ratings may be adjusted with EI-rated bar stock or members from Tables 2-29 and 2-30
- Supplemental members may be attached to the duct wall on both sides of the joint
- Single members may be used if they are fastened through both mating flanges
- Gasket to be located to form an effective seal

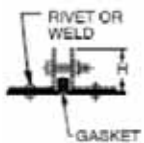

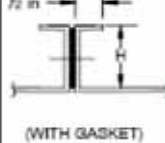
EI Ratings

Reinf. Class			 H = 1 1/2 in. (WITH GASKET)		 1/2 in. (WITH GASKET)		 H = 1 1/2 in. WITH GASKET T-25a Flanged  H = 1 1/2 in. WITH GASKET T-25b Flanged		
	T-22 Companion Angles		T-24 Flanged		T-24a Flanged				
	E1*	H x T	WT	T (Nom.)	WT	H x T (Nom.)	WT	H x T (Nom.)	WT
		LF			LF		LF		LF
B	1.0	Use E		Use D		Use D		Use D	
C	1.9	Use E		Use D		Use D		Use D	
D	2.7	Use E		26 ga	0.5	1 x 22 ga	0.4	26 ga	0.5



EI Ratings

Reinf. Class	Angle		Channel or Zee		Hat Section	
	H x T (MIN)	WT LF	H x B x T (MIN)	WT LF	H x B x D x T (MIN)	WT LF
A	Use C		Use B		Use F	
B	Use C		$\frac{3}{4} \times \frac{1}{2} \times 20$ ga	0.24	Use F	
C	C 1×16 ga	0.40	$\frac{3}{4} \times \frac{1}{2} \times 18$ ga	0.31	Use F	
	C $\frac{3}{4} \times \frac{1}{2}$	0.57	$1 \times \frac{3}{4} \times 20$ ga			
D	H $\frac{3}{4} \times \frac{1}{2}$	0.57	$1 \times \frac{3}{4} \times 18$ ga	0.45	Use F	
	C $1 \times \frac{1}{2}$	0.80				
E	C $1 \frac{1}{4} \times 12$ ga H $1 \times \frac{1}{2}$	0.90	$2 \times 1 \frac{1}{2} \times 20$ ga	0.60	Use F	
F	H $1 \frac{1}{4} \times \frac{1}{2}$	1.02	$1 \frac{1}{2} \times \frac{3}{4} \times 18$ ga	0.54	$1 \frac{1}{2} \times \frac{3}{4} \times \frac{3}{4} \times 18$ ga	0.90
					$1 \frac{1}{2} \times 1 \frac{1}{2} \times \frac{3}{4} \times 20$ ga	0.83



Example 3

- Pressure class negative 4 in. w.g.
- Size 36 x 30
- 5 ft joint using TDC/TDF
- External reinforcement only

Example 3

4 in. wg Static Pos. or Neg.	No Reinforcement Required	Rein
Duct		