

INTERNATIONAL CODE COUNCIL

2009/2010 CODE DEVELOPMENT CYCLE

PROPOSED CHANGES TO THE 2009 EDITIONS OF THE

INTERNATIONAL BUILDING CODE®
INTERNATIONAL ENERGY CONSERVATION CODE®
INTERNATIONAL EXISTING BUILDING CODE®
INTERNATIONAL FIRE CODE®
INTERNATIONAL FUEL GAS CODE®
INTERNATIONAL MECHANICAL CODE®
INTERNATIONAL PLUMBING CODE®
INTERNATIONAL PRIVATE SEWAGE DISPOSAL CODE®
INTERNATIONAL PROPERTY MAINTENANCE CODE®
INTERNATIONAL RESIDENTIAL CODE®
INTERNATIONAL WILDLAND-URBAN INTERFACE CODE®
INTERNATIONAL ZONING CODE®

October 24 2009 – November 11, 2009

Hilton Baltimore
Baltimore, MD



First Printing

Publication Date: August 2009

Copyright © 2009

By

International Code Council, Inc.

ALL RIGHTS RESERVED. This 2009/2010 Code Development Cycle Proposed Changes to the 2009 *International Codes* is a copyrighted work owned by the International Code Council, Inc. Without advanced written permission from the copyright owner, no part of this book may be reproduced, distributed, or transmitted in any form or by any means, including, without limitations, electronic, optical or mechanical means (by way of example and not limitation, photocopying, or recording by or in an information storage retrieval system). For information on permission to copy material exceeding fair use, please contact: Publications, 4051 West Flossmoor Road, Country Club Hills, IL 60478 (Phone 1-888-422-7233).

Trademarks: "International Code Council," the "International Code Council" logo are trademarks of the International Code Council, Inc.

PRINTED IN THE U.S.A.

TABLE OF CONTENTS

	PAGE
Introduction	iii
2009 ICC Code Development Hearings	iii
Registration and Voting	iii
Advanced Registration	iv
Code Development Process Changes	iv
Procedures	iv
Assembly Action	v
Multiple Part Code Change Proposals	v
Administrative Code Development Committee	v
Analysis Statements	v
Reference Standards	vi
Referenced Standards Updates	vi
Modifications	vi
Code Correlation Committee	vi
2009/2010 Code Development Schedule	vii
2009/2010 Staff Secretaries	ix
Scoping Revisions — Within the IBC	x
ICC Website	xi
CP #28-05 Code Development	xii
Cross Index of Proposed Changes	xxiii
Hearing Schedule	xxxii
2009/2010 Proposed Changes	xxxiii
2009/2010 Registration Form	xxxiv

INTRODUCTION

The proposed changes published herein have been submitted in accordance with established procedures and are distributed for review. The publication of these changes constitutes neither endorsement nor question of them but is in accordance with established procedures so that any interested individuals may make their views known to the relevant code committee and others similarly interested. In furtherance of this purpose, the committee will hold an open public hearing at the date and place shown below for the purpose of receiving comments and arguments for or against such proposed changes. Those who are interested in testifying on any of the published changes are expected to be represented at these hearings.

This compilation of code change proposals is available in electronic form only. As part of ICC's green initiative, ICC will no longer print and distribute this document. The compilation of code change proposals will be posted on the ICC website, and CD copies will be distributed to all interested parties on our list.

2009 ICC CODE DEVELOPMENT HEARINGS

These proposed changes will be discussed in public hearings to be held on October 24, 2009 through October 31, 2009 and November 4-11, 2009 at the Hilton Baltimore, Baltimore, Maryland. The code committees will conduct their public hearings in accordance with the schedule shown on page xxxii.

REGISTRATION AND VOTING

All members of ICC may vote on any assembly motion on proposed code changes to all International Codes. **For identification purposes, eligible voting members must register, at no cost, in order to vote.** The registration desk will be open in the lobby of the convention center according to the following schedule:

Friday, October 23 rd	3:00 pm to 6:00 pm
Saturday, October 24 th through Wednesday November 11 th	7:30 am to 5:00 pm

Council Policy #28-Code Development (page xii) requires that ICC's membership records regarding ICC members reflect the eligible voters 10 days prior to the start of the Code Development Hearings. This process includes new as well as changes to voting status. Section 5.7.4 of CP #28 (page xix) reads as follows:

5.7.4 Eligible Voters: All members of ICC in attendance at the public hearing shall be eligible to vote on floor motions. Only one vote authorized for each eligible attendee. Code Development Committee member shall be eligible to vote on floor motions. Application, whether new or updated, for ICC membership must be received by the Code Council ten days prior to the commencement of the first day of the public hearing.

As such, new membership application as well as renewal applications must be received by ICC's Member Services Department by October 14, 2009. These records will be used to verify eligible voter status for the Code Development Hearings. Members are strongly encouraged to review their membership records for accuracy well in advance of the hearings so that any necessary changes are made prior to the October 14, 2009 deadline. For information on application for new membership and membership renewal, please go to www.iccsafe.org/membership/join.html or call ICC Member Services at 1-888-ICC SAFE (422-7233)

It should be noted that a corporate member has a single vote. Only one representative of a corporate member will be issued a voting badge. ICC Staff will be contacting corporate members regarding who the designated voting representative will be.

ADVANCED REGISTRATION

You are encouraged to advance register by filling out the registration form available at www.iccsafe.org/codesforum.

CODE DEVELOPMENT PROCESS CHANGES

As noted in the posted Advisory Statement of February 4, 2009, the revised Code Development Process includes maintaining the current 3-year publication cycle with a single cycle of code development between code editions. The schedule for the 2009/2010 Code Development Cycle is the transitional schedule for the revised code development process. As noted, there will be two Final Action Hearings in 2010—one for the modified Group A, and one for the modified Group B. The codes that will comprise the Group A and Group B hearings will be announced prior to the Code Development Hearings in Baltimore. See the Code Development Process Notes included with the Schedule on page viii.

PROCEDURES

The procedures for the conduct of the public hearing are published in *Council Policy #28-Code Development (CP#28)* ("Procedures") on page xii. The attention of interested parties is specifically directed to Section 5.0 of the Procedures. These procedures indicate the conduct of, and opportunity to participate in the ICC Code Development Process. Please review these procedures carefully to familiarize yourself with the process.

There have been a number of revisions to the procedures. Included among these revisions are the following:

- Section 2.3: **Supplements:** ICC will no longer produce a Supplement to each edition of the I-Codes. A new edition of the I-Codes will be based upon activity of a single code change cycle.
- Section 3.3.3: **Multiple code change proposals:** A proponent is not permitted to submit multiple code changes to one section of a code unless the subject matter of each proposal is different.
- Section 4.5.1: **Administrative update of standards:** Updating of standards without a change to code text (administrative update) shall be a code change proposal dealt with by the Administrative Code Development Committee. The updating of standards procedures have also changed. See discussion on updating of standards on page vi.
- Section 4.7: **Code change posting:** All code change proposals are required to be posted on the ICC website 30 days before the code development hearings. Published copies will not be provided.
- Section 5.2.2: **Conflict of interest:** Clarification is added that a committee member who steps down from the dais because of a conflict of interest is allowed to provide testimony from the floor on that code change proposal.
- Section 5.4.6.2: **Proponent rebuttal testimony:** Where the code change proposal is submitted by multiple proponents, only one proponent of the joint submittal to be allotted additional time for rebuttal.
- Section 5.5.2: **Modifications:** The chair rules a modification in or out of order. The chair's decision is final. No challenge in a point of order is allowed for this ruling.

Section 5.7.3: **Assembly Actions:** Several changes have been made to assembly actions. See explanation page v

Section 7.3.8.2: **Initial motion at final action hearings:** A successful assembly action becomes the initial motion at the final action hearings. See explanation page v.

ASSEMBLY ACTION

The procedures regarding assembly action at the Code Development Hearings have been revised to place more weight on the results of that action (see Section 5.7 of CP #28 on page viii). Some important items to note regarding assembly action are:

- A successful assembly action now requires a 2/3 majority rather than a simple majority.
- After the committee decision on a code change proposal is announced by the moderator, any one in the assembly may make a motion for assembly action.
- After a motion for assembly action is made and seconded, the moderator calls for a floor vote in accordance with Section 5.7.2. *No additional testimony will be permitted.*
- A successful assembly action becomes the initial motion considered at the Final Action Hearings. This also means that the required vote at the Final Action Hearings to uphold the assembly action is a simple majority.

MULTIPLE PART CODE CHANGE PROPOSALS

It is common for ICC to receive code change proposals for more than one code or more than 1 part of a code that is the responsibility of more than one committee. For instance, a code change proposal could be proposing related changes to the text of IBC Chapter 4 (IBC-General), IBC Chapter 7 (IBC-Fire Safety), and the IFC Chapter 27 (IFC). When this occurs, a single committee will now hear all of the parts, unless one of the parts is a change to the IRC, in which case the respective IRC committee will hear that part separately.

ADMINISTRATIVE CODE DEVELOPMENT COMMITTEE

A new committee for the 2009/2010 Code Change Cycle and going forward is the Administrative Code Development Committee. This committee will hear code change proposals to the administrative provisions of the I-Codes (Chapter 1 of each code.) The purpose of this committee is to achieve, inasmuch as possible, uniformity in the administrative provisions of all I-Codes when such uniformity is warranted.

ANALYSIS STATEMENTS

Various proposed changes published herein contain an “analysis” that appears after the proponent’s reason. These comments do not advocate action by the code committees or the voting membership for or against a proposal. The purpose of such comments is to identify pertinent information that is relevant to the consideration of the proposed change by all interested parties, including those testifying, the code committees and the voting membership. Staff analyses customarily identify such things as: conflicts and duplication within a proposed change and with other proposed changes and/or current code text; deficiencies in proposed text and/or substantiation; text problems such as wording defects and vagueness; background information on the development of current text; and staff’s review of proposed reference standards for compliance with the Procedures. Lack of an analysis indicates neither support for, nor opposition to a proposal.

REFERENCE STANDARDS

Proposed changes that include the addition of a reference to a new standard (i.e. a standard that is not currently referenced in the I-Codes.) will include in the proposal the number, title and edition of the proposed standard. This identifies to all interested parties the precise document that is being proposed and which would be included in the referenced standards chapter of the code if the proposed change is approved. Proponents of code changes which propose a new standard have been directed to forward copies of the standard to the Code Committee and an analysis statement will be posted on the ICC website indicating the status of compliance of the standard with the ICC referenced standards criteria in Section 3.6 of CP #28 (see page xiv). (See the ICC Website page xi) The analysis statements for referenced standards will be posted on or before September 24, 2009. This information will also be published and made available at the hearings.

REFERENCED STANDARDS UPDATES

At the end of the agenda of the Administrative Code Development Committee is a code change proposal that is an administrative update of the referenced standards contained in the I-Codes. This code change proposal, ADM39-09/10 contains a list of standards for which the respective promulgators have indicated that the standard has been updated. The codes that these standards appear in are indicated beside each listed referenced standard. This update will then apply to every code in which the standard appears.

It should be noted that in accordance with Section 4.5.1 of CP #28 (see page xvi), standards promulgators have until December 1, 2011 to finalize and publish any updates to standards in the administrative update. If the standard is not finalized by December 1, 2011, the code will be revised to reference the previously listed year edition of that standard.

MODIFICATIONS

Those who are submitting modification for consideration by the respective Code Development Committee are required to submit a Copyright Release in order to have their modifications considered (Section 3.3.4.5 of CP #28). It is preferred that such release be executed in advance – the form is at <http://www.iccsafe.org/cs/codes/publicforms.htm>. Copyright release forms will also be available at the hearings. Please note that an individual need only sign one copyright release for submittals of all code change proposals, modification, and public comments in this code change cycle for which the individual might be responsible. **Please be sure to review Section 5.5.2 of CP #28 for the modification process.** The Chair of the respective code development committee rules a modification in or out of order. That ruling is final, with no challenge allowed. The proponent submitting a modification is required to supply 20 printed copies. The minimum font size must be 12 point.

CODE CORRELATION COMMITTEE

In every code change cycle, there are code change proposals that are strictly editorial. The Code Correlation Committee approves all proposals deemed editorial. A list of code correlation committee actions will be posted on the ICC website by September 24, 2009.

2009/2010 ICC CODE DEVELOPMENT SCHEDULE

STEP IN CODE DEVELOPMENT CYCLE	DATE	
DEADLINE FOR RECEIPT OF APPLICATIONS FOR CODE COMMITTEES	January 2, 2009	
DEADLINE FOR RECEIPT OF CODE CHANGE PROPOSALS	June 1, 2009	
WEB POSTING OF "PROPOSED CHANGES TO THE I-CODES"	August 24, 2009	
DISTRIBUTION DATE OF "PROPOSED CHANGES TO THE I-CODES" (Limited distribution – see notes)	October 3, 2009	
CODE DEVELOPMENT HEARING (CDH) ALL CODES – see notes	October 24 2009 – November 11, 2009 Hilton Baltimore Baltimore, MD	
WEB POSTING OF "REPORT OF THE PUBLIC HEARING"	December 16, 2009	
DISTRIBUTION DATE OF "REPORT OF THE PUBLIC HEARING" (Limited distribution – see notes)	January 11, 2010	
IN ACCORDANCE WITH THE NEW CODE DEVELOPMENT PROCESS (see notes), THE CODES WILL BE SPLIT INTO TWO GROUPS WITH SEPARATE PUBLIC COMMENT DEADLINES AND FINAL ACTION HEARINGS		
	GROUP A (see notes)	GROUP B (see notes)
DEADLINE FOR RECEIPT OF PUBLIC COMMENTS	February 8, 2010	July 1, 2010
WEB POSTING OF PUBLIC COMMENTS "FINAL ACTION AGENDA"	March 15, 2010	August 26, 2010
DISTRIBUTION DATE OF PUBLIC COMMENTS "FINAL ACTION AGENDA" (Limited distribution see notes)	April 16, 2010	September 27, 2010
FINAL ACTION HEARINGS (FAH)	May 14 – 23, 2010 Dallas, TX	Oct 28 – Nov 1, 1020 Charlotte, NC
ANNUAL CONFERENCES	<p><u>October 24 – November 11, 2009</u> 2009 ICC Annual Conference and Code Development Hearing Balitmore, MD</p> <p><u>October 25 – November 1, 2010</u> 2010 ICC Annual Conference and Final Action Hearing Charlotte, NC</p>	
RESULTING PUBLICATION	2012 – I-Codes (available April, 2011)	

Code Development Process Notes:

As noted in the posted Advisory Statement of February 4, 2009, the revised Code Development Process includes maintaining the current 3-year publication cycle with a single cycle of code development between code editions. Implemented as follows:

- Transitional Process – 2009/2010 only
 - Single Code Development Hearing (CDH) for all codes in 2009
 - Two Final Action Hearings (FAH) in 2010 – modified Groups A and B (see below)
 - Public 2012 edition in April, 2011
- New Process – 2012/2013 and going forward
 - Code Committee application deadline (all codes); June 1, 2011
 - Codes split into two groups: Group A and Group B
 - Group A: IBC; IFGC; IMC; IPC; IPSDC
 - Code change deadline: January 3, 2012
 - Code Development Hearing: April/May 2012
 - Final Action Hearing: October/November 2012 (in conjunction with Annual Conference)
 - Group B: Admin (Ch. 1 of I-Codes); IEBC; IECC; IFC; IPerfC; IPMC; IRC; IWUIC; IZC
 - Code change deadline: January 3, 2013
 - Code Development Hearing: April/May 2013
 - Final Action Hearing: October/November 2013 (in conjunction with Annual Conference)
 - Publish 2015 edition in April, 2014
 - Repeat for subsequent editions

2009/2010 Cycle Notes:

- Revised code change deadline of June 1st posted on March 19th
- Distribution date: Complimentary code development cycle document distribution will be limited to CD's mailed to those who are on ICC's code change document mailing list.
- Code Development Hearings: The Baltimore Code Development Hearings will include 12 I-Codes (no changes to the ICC Performance Code. The hearings will be held in the conventional two track format with the hearings split before and after the Annual Conference during the periods of October 24 – 31 and November 4 – 11. The specific codes and hearing order to be determined based on code change volume.
- Final Action Hearing Groupings: Final Action Hearing logistics dictate that the hearings will not be split along established Group A and B codes (see above) due to hotel commitments which limit the amount of hearing time at the October/2010 FAH versus the May/2010 FAH. Tentatively, the May/2010 FAH will include Group A codes plus certain Group B codes to be determined based on code change volume.

2009/2010 STAFF SECRETARIES

IBC-General Chapters 1-6, 12, 13, 27-34	IBC-Fire Safety Chapters 7, 8, 9, 14, 26	IBC-Means of Egress Chapters 10, 11	IBC-Structural Chapters 15-25
Kermit Robinson ICC Whittier District Office 1-888-ICC-SAFE, ext. 3317 FAX: 562/699-4522 krobinson@iccsafe.org	Ed Wirtschoreck ICC Chicago District Office 1-888-ICC-SAFE, ext 4317 FAX: 708/799-0320 ewirtschoreck@iccsafe.org	Kim Paarlberg ICC Indianapolis Field Office 1-888-ICC-SAFE, ext 4306 FAX: 708/799-0320 kpearlberg@iccsafe.org	Alan Carr ICC NW Resource Center 1-888-ICC-SAFE, ext 7601 FAX: 425/637-8939 acarr@iccsafe.org

IEBC	IECC	IFC	IFGC
Beth Tubbs ICC Northbridge Field Office 1-888-ICC-SAFE, ext 7708 FAX: 419/ 730-6531 btubbs@iccsafe.org	Dave Bowman ICC Chicago District Office 1-888-ICC-SAFE, ext 4323 FAX: 708/799-0320 dmeyers@iccsafe.org	Bill Rehr/ Beth Tubbs ICC Chicago District Office 1-888-ICC-SAFE, ext 4342 FAX: 708/799-0320 brehr@iccsafe.org btubbs@iccsafe.org	Gregg Gress ICC Chicago District Office 1-888-ICC-SAFE, ext 4343 FAX: 708/799-0320 ggress@iccsafe.org

IMC	ICC PC	IPMC	IPC/IPSDC
Gregg Gress ICC Chicago District Office 1-888-ICC-SAFE, ext 4343 FAX: 708/799-0320 ggress@iccsafe.org	Beth Tubbs ICC Northbridge Field Office 1-888-ICC-SAFE, ext 7708 FAX: 419/ 730-6531 btubbs@iccsafe.org	Ed Wirtschoreck ICC Chicago District Office 1-888-ICC-SAFE, ext 4317 FAX: 708/799-0320 ewirtschoreck@iccsafe.org	Fred Grable ICC Chicago District Office 1-888-ICC-SAFE, ext 4359 FAX: 708/799-0320 fgrable@iccsafe.org

IRC-Building/Energy	IRC Mechanical	IRC Plumbing	IWUIC
Larry Franks/ Dave Bowman ICC Northbridge Field Office 1-888-ICC-SAFE, ext 5279 FAX: 205/592-7001 lfranks@iccsafe.org dbowman@iccsafe.org	Gregg Gress ICC Chicago District Office 1-888-ICC-SAFE, ext 4343 FAX: 708/799-0320 ggress@iccsafe.org	Fred Grable ICC Chicago District Office 1-888-ICC-SAFE, ext 4359 FAX: 708/799-0320 fgrable@iccsafe.org	Bill Rehr ICC Chicago District Office 1-888-ICC-SAFE, ext 4342 FAX: 708/799-0320 brehr@iccsafe.org

IZC	ADMINISTRATIVE Chapter 1 All Codes Except IRC
Ed Wirtschoreck ICC Chicago District Office 1-888-ICC-SAFE, ext 4317 FAX: 708/799-0320 ewirtschoreck@iccsafe.org	Dave Bowman ICC Chicago District Office 1-888-ICC-SAFE, ext 4323 FAX: 708/799-0320 dbowman@iccsafe.org

SCOPING REVISIONS – WITHIN THE IBC

The 2009/2010 Staff Secretaries assignments on page ix indicate which chapters of the International Building Code are generally within the responsibility of each IBC Code Committee. However, within each of these IBC Chapters are subjects that are most appropriately maintained by another IBC Code Committee. For example, the provisions of Section 3008.1 deal with occupant evacuation elevators. Therefore, even though Chapter 30 is within the responsibility of the IBC General Committee, this section would most appropriately be maintained by the IBC Means of Egress Committee. The following table indicates responsibilities by IBC Code Committees other than the main committee for those chapters, for code changes submitted for the 2009/2010 Cycle.

SECTION	CHAPTER MAINTAINED BY	SECTION MAINTAINED BY	CODE CHANGES
403.2.3	IBC-General	IBC-Structural	E5 Part I (Heard by IBC-MOE)
403.5.1	IBC-General	IBC-Structural	E5 Part I (Heard by IBC-MOE)
403.5.2	IBC-General	IBC-Means of Egress	G46
403.5.4	IBC-General	IBC-Structural	E5 Part I (Heard by IBC-MOE)
403.5.4	IBC-General	IBC-Means of Egress	G47
403.6.1	IBC-General	IBC-Means of Egress	G48, G49
408.3.8	IBC-General	IBC-Structural	E5 Part I (Heard by IBC-MOE)
410.5.3.1	IBC-General	IBC-Structural	E5 Part I (Heard by IBC-MOE)
419.3.0	IBC-General	IBC-Means of Egress	G79
1505.1.0	IBC-Structural	IBC-Fire Safety	S10, S11
1505.8.0	IBC-Structural	IBC-Fire Safety	S12, S13
1507.16.0	IBC-Structural	IBC-Fire Safety	S10, S11
1508.1.0	IBC-Structural	IBC-Fire Safety	S24
1508.2.0	IBC-Structural	IBC-Fire Safety	S25
1509.0.0	IBC-Structural	IBC-General	S26, S27
1509.6.(new)	IBC-Structural	IBC-General	S28
1704.15.0	IBC-Structural	IBC-Fire Safety	S126, S127,S128
3007.1.0	IBC-General	IBC-Means of Egress	G48,G157
3007.2.(new)	IBC-General	IBC-Means of Egress	G158, G159
3007.2.0	IBC-General	IBC-Means of Egress	G160
3007.3.(new)	IBC-General	IBC-Means of Egress	G158, G161
3007.4.(new)	IBC-General	IBC-Means of Egress	G162
3007.4.2	IBC-General	IBC-Means of Egress	G163
3007.4.3	IBC-General	IBC-Means of Egress	G176
3007.5.1.(NEW)	IBC-General	IBC-Means of Egress	G164
3007.7.1	IBC-General	IBC-Means of Egress	G165, G166
3007.8.0	IBC-General	IBC-Means of Egress	G167
3008.1.0	IBC-General	IBC-Means of Egress	G168, G170
3008.1.1	IBC-General	IBC-Means of Egress	G169
3008.10.0	IBC-General	IBC-Means of Egress	G174
3008.10.1	IBC-General	IBC-Means of Egress	G175
3008.11.3	IBC-General	IBC-Means of Egress	G176
3008.11.5	IBC-General	IBC-Means of Egress	G177
3008.3.(NEW)	IBC-General	IBC-Means of Egress	G165, G166
3008.4.(NEW)	IBC-General	IBC-Means of Egress	G171
3008.4.0	IBC-General	IBC-Means of Egress	G46
3008.7.0	IBC-General	IBC-Means of Egress	G172
3008.9.0	IBC-General	IBC-Means of Egress	G173
3401.4.0	IBC-General	IBC-Structural	G190
3401.4.1	IBC-General	IBC-Structural	G191
3401.4.3	IBC-General	IBC-Structural	G190
3401.5.(NEW)	IBC-General	IBC-Structural	G192

SECTION	CHAPTER MAINTAINED BY	SECTION MAINTAINED BY	CODE CHANGES
3402.1.0	IBC-General	IBC-Structural	G193
3403.4.1	IBC-General	IBC-Structural	G190
3404.4.1	IBC-General	IBC-Structural	G190
3405.1.1	IBC-General	IBC-Structural	G192
3405.2.0	IBC-General	IBC-Structural	G193, G194
3405.2.1	IBC-General	IBC-Structural	G193, G190
3405.2.2	IBC-General	IBC-Structural	G193
3405.2.3	IBC-General	IBC-Structural	G193, G195
3405.3.0	IBC-General	IBC-Structural	G193
3405.4.0	IBC-General	IBC-Structural	G193, G194
3405.5.0	IBC-General	IBC-Structural	G196
3408.4.0	IBC-General	IBC-Structural	G190, G197
3408.4.0	IBC-General	IBC-Structural	G190
403.2.3	IBC-General	IBC-Structural	E5 Part I (Heard by IBC-MOE)
403.5.1	IBC-General	IBC-Structural	E5 Part I (Heard by IBC-MOE)
403.5.2	IBC-General	IBC-Means of Egress	G46
403.5.4	IBC-General	IBC-Structural	E5 Part I (Heard by IBC-MOE)
403.5.4	IBC-General	IBC-Means of Egress	G47
403.6.1	IBC-General	IBC-Means of Egress	G48, G49
408.3.8	IBC-General	IBC-Structural	E5 Part I (Heard by IBC-MOE)
410.5.3.1	IBC-General	IBC-Structural	E5 Part I (Heard by IBC-MOE)
419.3.0	IBC-General	IBC-Means of Egress	G79

ICC WEBSITE – [WWW.ICCSAFE.ORG](http://www.iccsafe.org)

While great care has been exercised in the publication of this document, errata to proposed changes may occur. Errata, if any, identified prior to the Code Development Hearings will be posted on the ICC website at <http://www.iccsafe.org>. Users are encouraged to periodically review the ICC Website for updates to errata to the 2009/2010 Code Development Cycle Proposed Changes. Additionally, analysis statements for code changes which propose a new referenced standard will be updated to reflect the staff review of the standard for compliance with Section 3.6 of the Procedures.



CP# 28-05 CODE DEVELOPMENT

Approved: 9/24/05

Revised: 2/27/09

CP # 28-05 is an update to *ICC's Code Development Process for the International Codes* dated May 15, 2004.

1.0 Introduction

- 1.1 **Purpose:** The purpose of this Council Policy is to prescribe the Rules of Procedure utilized in the continued development and maintenance of the International Codes (Codes).
- 1.2 **Objectives:** The ICC Code Development Process has the following objectives:
 - 1.2.1 The timely evaluation and recognition of technological developments pertaining to construction regulations.
 - 1.2.2 The open discussion of proposals by all parties desiring to participate.
 - 1.2.3 The final determination of Code text by officials representing code enforcement and regulatory agencies and by honorary members.
- 1.3 **Code Publication:** The ICC Board of Directors (ICC Board) shall determine the title and the general purpose and scope of each Code published by the ICC.
 - 1.3.1 **Code Correlation:** The provisions of all Codes shall be consistent with one another so that conflicts between the Codes do not occur. Where a given subject matter or code text could appear in more than one Code, the ICC Board shall determine which Code shall be the primary document, and therefore which code development committee shall be responsible for review and maintenance of the code text. Duplication of content or text between Codes shall be limited to the minimum extent necessary for practical usability of the Codes, as determined in accordance with Section 4.4.
- 1.4 **Process Maintenance:** The review and maintenance of the Code Development Process and these Rules of Procedure shall be by the ICC Board. The manner in which ICC codes are developed embodies core principles of the organization. One of those principles is that the final content of ICC codes is determined by a majority vote of the governmental and honorary members. It is the policy of the Board that there shall be no change to this principle without the affirmation of two-thirds of the governmental and honorary members responding.
- 1.5 **Secretariat:** The Chief Executive Officer shall assign a Secretariat for each of the Codes. All correspondence relating to code change proposals and public comments shall be addressed to the Secretariat.
- 1.6 **Video Taping:** Individuals requesting permission to video tape any meeting, or portion thereof, shall be required to provide the ICC with a release of responsibility disclaimer and shall acknowledge that they have insurance coverage for liability and misuse of video tape materials. Equipment and the process used to video tape shall, in the judgment of the ICC Secretariat, be conducted in a manner that is not disruptive to the meeting. The ICC shall not be responsible for equipment, personnel or any other provision necessary to accomplish the videotaping. An unedited copy of the video tape shall be forwarded to ICC within 30 days of the meeting.

2.0 Code Development Cycle

- 2.1 **Intent:** The code development cycle shall consist of the complete consideration of code change proposals in accordance with the procedures herein specified, commencing with the deadline for submission of code change proposals (see Section 3.5) and ending with publication of final action on the code change proposals (see Section 7.6).

- 2.2 **New Editions:** The ICC Board shall determine the schedule for publishing new editions of the Codes. Each new edition shall incorporate the results of the code development activity since the last edition.
- 2.3 **Supplements:** The results of code development activity between editions may be published.
- 2.4 **Emergency Procedures:** In the event that the ICC Board determines that an emergency amendment to any Code is warranted, the same may be adopted by the ICC Board. Such action shall require an affirmative vote of at least two-thirds of the ICC Board.

The ICC membership shall be notified within ten days after the ICC Boards' official action of any emergency amendment. At the next Annual Business Meeting, any emergency amendment shall be presented to the members for ratification by a majority of the ICC Governmental Member Representatives and Honorary Members present and voting.

All code revisions pursuant to these emergency procedures and the reasons for such corrective action shall be published as soon as practicable after ICC Board action. Such revisions shall be identified as an emergency amendment.

Emergency amendments to any Code shall not be considered as a retro-active requirement to the Code. Incorporation of the emergency amendment into the adopted Code shall be subjected to the process established by the adopting authority.

3.0 Submittal of Code Change Proposals

- 3.1 **Intent:** Any interested person, persons or group may submit a code change proposal which will be duly considered when in conformance to these Rules of Procedure.
- 3.2 **Withdrawal of Proposal:** A code change proposal may be withdrawn by the proponent (WP) at any time prior to Final Action Consideration of that proposal. A withdrawn code change proposal shall not be subject to a public hearing, motions, or Final Action Consideration.
- 3.3 **Form and Content of Code Change Submittals:** Each code change proposal shall be submitted separately and shall be complete in itself. Each submittal shall contain the following information:
 - 3.3.1 **Proponent:** Each code change proposal shall include the name, title, mailing address, telephone number, and email address of the proponent.
 - 3.3.1.1 If a group, organization or committee submits a code change proposal, an individual with prime responsibility shall be indicated.
 - 3.3.1.2 If a proponent submits a code change on behalf of a client, group, organization or committee, the name and mailing address of the client, group, organization or committee shall be indicated.
 - 3.3.2 **Code Reference:** Each code change proposal shall relate to the applicable code sections(s) in the latest edition of the Code.
 - 3.3.2.1 If more than one section in the Code is affected by a code change proposal, appropriate proposals shall be included for all such affected sections.
 - 3.3.2.2 If more than one Code is affected by a code change proposal, appropriate proposals shall be included for all such affected Codes and appropriate cross referencing shall be included in the supporting information.
 - 3.3.3 **Multiple code change proposals to a code section.** A proponent shall not submit multiple code change proposals to the same code section. When a proponent submits multiple code change proposals to the same section, the proposals shall be considered as incomplete proposals and processed in accordance with Section 4.3. This restriction shall not apply to code change proposals that attempt to address differing subject matter within a code section.
 - 3.3.4 **Text Presentation:** The text proposal shall be presented in the specific wording desired with deletions shown struck out with a single line and additions shown underlined with a single line.

- 3.3.4.1 A charging statement shall indicate the referenced code section(s) and whether the proposal is intended to be an addition, a deletion or a revision to existing Code text.
 - 3.3.4.2 Whenever practical, the existing wording of the text shall be preserved with only such deletions and additions as necessary to accomplish the desired change.
 - 3.3.4.3 Each proposal shall be in proper code format and terminology.
 - 3.3.4.4 Each proposal shall be complete and specific in the text to eliminate unnecessary confusion or misinterpretation.
 - 3.3.4.5 The proposed text shall be in mandatory terms.
- 3.3.5 **Supporting Information:** Each code change proposal shall include sufficient supporting information to indicate how the proposal is intended to affect the intent and application of the Code.
- 3.3.5.1 **Purpose:** The proponent shall clearly state the purpose of the proposed code change (e.g. clarify the Code; revise outdated material; substitute new or revised material for current provisions of the Code; add new requirements to the Code; delete current requirements, etc.)
 - 3.3.5.2 **Reasons:** The proponent shall justify changing the current Code provisions, stating why the proposal is superior to the current provisions of the Code. Proposals which add or delete requirements shall be supported by a logical explanation which clearly shows why the current Code provisions are inadequate or overly restrictive, specifies the shortcomings of the current Code provisions and explains how such proposals will improve the Code.
 - 3.3.5.3 **Substantiation:** The proponent shall substantiate the proposed code change based on technical information and substantiation. Substantiation provided which is reviewed in accordance with Section 4.2 and determined as not germane to the technical issues addressed in the proposed code change shall be identified as such. The proponent shall be notified that the proposal is considered an incomplete proposal in accordance with Section 4.3 and the proposal shall be held until the deficiencies are corrected. The proponent shall have the right to appeal this action in accordance with the policy of the ICC Board. The burden of providing substantiating material lies with the proponent of the code change proposal.
 - 3.3.5.4 **Bibliography:** The proponent shall submit a bibliography of any substantiating material submitted with the code change proposal. The bibliography shall be published with the code change and the proponent shall make the substantiating materials available for review at the appropriate ICC office and during the public hearing.
 - 3.3.5.5 **Copyright Release:** The proponent of code change proposals, floor modifications and public comments shall sign a copyright release reading: "I hereby grant and assign to ICC all rights in copyright I may have in any authorship contributions I make to ICC in connection with any proposal and public comment, in its original form submitted or revised form, including written and verbal modifications submitted in accordance Section 5.5.2. I understand that I will have no rights in any ICC publications that use such contributions in the form submitted by me or another similar form and certify that such contributions are not protected by the copyright of any other person or entity."
 - 3.3.5.6 **Cost Impact:** The proponent shall indicate one of the following regarding the cost impact of the code change proposal: 1) the code change proposal will increase the cost of construction; or 2) the code change proposal will not increase the cost of construction. This information will be included in the published code change proposal.
- 3.4 **Number:** One copy of each code change proposal, two copies of each proposed new referenced standard and one copy of all substantiating information shall be submitted. Additional copies may be requested when determined necessary by the Secretariat to allow such information to be distributed to the code development committee. Where such additional copies are requested, it shall be the responsibility of the proponent to send such copies to the respective code development committee. A copy of the code change proposal in electronic form is preferred.
- 3.5 **Submittal Deadline:** Each code change proposal shall be received at the office of the Secretariat by the posted deadline. Such posting shall occur no later than 120 days prior to the code change deadline. The submitter of a proposed code change is responsible for the proper and timely receipt of all pertinent materials by the Secretariat.
- 3.6 **Referenced Standards:** In order for a standard to be considered for reference or to continue to be referenced by the Codes, a standard shall meet the following criteria:

3.6.1 Code References:

- 3.6.1.1** The standard, including title and date, and the manner in which it is to be utilized shall be specifically referenced in the Code text.
- 3.6.1.2** The need for the standard to be referenced shall be established.

3.6.2 Standard Content:

- 3.6.2.1** A standard or portions of a standard intended to be enforced shall be written in mandatory language.
- 3.6.2.2** The standard shall be appropriate for the subject covered.
- 3.6.2.3** All terms shall be defined when they deviate from an ordinarily accepted meaning or a dictionary definition.
- 3.6.2.4** The scope or application of a standard shall be clearly described.
- 3.6.2.5** The standard shall not have the effect of requiring proprietary materials.
- 3.6.2.6** The standard shall not prescribe a proprietary agency for quality control or testing.
- 3.6.2.7** The test standard shall describe, in detail, preparation of the test sample, sample selection or both.
- 3.6.2.8** The test standard shall prescribe the reporting format for the test results. The format shall identify the key performance criteria for the element(s) tested.
- 3.6.2.9** The measure of performance for which the test is conducted shall be clearly defined in either the test standard or in Code text.
- 3.6.2.10** The standard shall not state that its provisions shall govern whenever the referenced standard is in conflict with the requirements of the referencing Code.
- 3.6.2.11** The preface to the standard shall announce that the standard is promulgated according to a consensus procedure.

3.6.3 Standard Promulgation:

- 3.6.3.1** Code change proposals with corresponding changes to the code text which include a reference to a proposed new standard or a proposed update of an existing referenced shall comply with this section. The standard shall be completed and readily available prior to Final Action Consideration based on the cycle of code development which includes the proposed code change proposal. In order for a new standard to be considered for reference by the Code, such standard shall be submitted in at least a consensus draft form in accordance with Section 3.4. Updating of standards without corresponding code text changes shall be accomplished administratively in accordance with Section 4.5.
- 3.6.3.2** The standard shall be developed and maintained through a consensus process such as ASTM or ANSI.

4.0 Processing of Proposals

- 4.1 Intent:** The processing of code change proposals is intended to ensure that each proposal complies with these Rules of Procedure and that the resulting published proposal accurately reflects that proponent's intent.
- 4.2 Review:** Upon receipt in the Secretariat's office, the code change proposals will be checked for compliance with these Rules of Procedure as to division, separation, number of copies, form, language, terminology, supporting statements and substantiating data. Where a code change proposal consists of multiple parts which fall under the maintenance responsibilities of different code committees, the Secretariat shall determine the code committee responsible for determining the committee action in accordance with Section 5.6.
- 4.3 Incomplete Proposals:** When a code change proposal is submitted with incorrect format, without the required information or judged as not in compliance with these Rules of Procedure, the Secretariat shall notify the proponent of the specific deficiencies and the proposal shall be held until the deficiencies are corrected, with a final date set for receipt of a corrected submittal. If the Secretariat receives the corrected proposal after the final date, the proposal shall be held over until the next code development cycle. Where there are otherwise no deficiencies addressed by this section, a proposal that incorporates a new referenced standard shall be processed with an analysis of referenced standard's compliance with the criteria set forth in Section 3.6.
- 4.4 Editorial:** The Chief Executive Officer shall have the authority at all times to make editorial and format changes to the Code text, or any approved changes, consistent with the intent, provisions and style of the Code. An editorial or format change is a text change that does not affect the scope or application of the code requirements.

4.5 Updating Standards:

4.5.1 Standards referenced in the 2012 Edition of the I-Codes: The updating of standards referenced by the Codes shall be accomplished administratively by the Administrative code development committee in accordance with these full procedures except that the deadline for availability of the updated standard and receipt by the Secretariat shall be December 1, 2011. The published version of the 2012 Code which references the standard will refer to the updated edition of the standard. If the standard is not available by the deadline, the edition of the standard as referenced by the newly published Code shall revert back to the reference contained in the previous edition and an errata to the Code issued. Multiple standards to be updated may be included in a single proposal.

4.5.2 Standards referenced in the 2015 Edition and following Editions of the I-Codes: The updating of standards referenced by the Codes shall be accomplished administratively by the Administrative code development committee in accordance with these full procedures except that multiple standards to be updated may be included in a single proposal. The standard shall be completed and readily available prior to Final Action Consideration of the Administrative code change proposal which includes the proposed update.

4.6 Preparation: All code change proposals in compliance with these procedures shall be prepared in a standard manner by the Secretariat and be assigned separate, distinct and consecutive numbers. The Secretariat shall coordinate related proposals submitted in accordance with Section 3.3.2 to facilitate the hearing process.

4.7 Publication: All code change proposals shall be posted on the ICC website at least 30 days prior to the public hearing on those proposals and shall constitute the agenda for the public hearing. Code change proposals which have not been published shall not be considered.

5.0 Public Hearing

5.1 Intent: The intent of the public hearing is to permit interested parties to present their views including the cost and benefits on the code change proposals on the published agenda. The code development committee will consider such comments as may be presented in the development of their action on the disposition of such proposals. At the conclusion of the code development committee deliberations, the committee action on each code change proposal shall be placed before the hearing assembly for consideration in accordance with Section 5.7.

5.2 Committee: The Code Development Committees shall be appointed by the applicable ICC Council.

5.2.1 Chairman/Moderator: The Chairman and Vice-Chairman shall be appointed by the Steering Committee on Councils from the appointed members of the committee. The ICC President shall appoint one or more Moderators who shall act as presiding officer for the public hearing.

5.2.2 Conflict of Interest: A committee member shall withdraw from and take no part in those matters with which the committee member has an undisclosed financial, business or property interest. The committee member shall not participate in any committee discussion on the matter or any committee vote. Violation thereof shall result in the immediate removal of the committee member from the committee. A committee member who is a proponent of a proposal shall not participate in any committee discussion on the matter or any committee vote. Such committee member shall be permitted to participate in the floor discussion in accordance with Section 5.5 by stepping down from the dais.

5.2.3 Representation of Interest: Committee members shall not represent themselves as official or unofficial representatives of the ICC except at regularly convened meetings of the committee.

5.2.4 Committee Composition: The committee may consist of representation from multiple interests. A minimum of thirty-three and one-third percent (33.3%) of the committee members shall be regulators.

5.3 Date and Location: The date and location of each public hearing shall be announced not less than 60 days prior to the date of the public hearing.

5.4 General Procedures: *The Robert's Rules of Order* shall be the formal procedure for the conduct of the public hearing except as a specific provision of these Rules of Procedure may otherwise dictate. A quorum shall consist of a majority of the voting members of the committee.

- 5.4.1 **Chair Voting:** The Chairman of the committee shall vote only when the vote cast will break a tie vote of the committee.
 - 5.4.2 **Open Meetings:** Public hearings of the Code Development Committees are open meetings. Any interested person may attend and participate in the Floor Discussion and Assembly Consideration portions of the hearing. Only eligible voters (see Section 5.7.4) are permitted to vote on Assembly Considerations. Only Code Development Committee members may participate in the Committee Action portion of the hearings (see Section 5.6).
 - 5.4.3 **Presentation of Material at the Public Hearing:** Information to be provided at the hearing shall be limited to verbal presentations and modifications submitted in accordance with Section 5.5.2. Audio-visual presentations are not permitted. Substantiating material submitted in accordance with Section 3.3.4.4 and other material submitted in response to a code change proposal shall be located in a designated area in the hearing room and shall not be distributed to the code development committee at the public hearing.
 - 5.4.4 **Agenda Order:** The Secretariat shall publish an agenda for each public hearing, placing individual code change proposals in a logical order to facilitate the hearing. Any public hearing attendee may move to revise the agenda order as the first order of business at the public hearing, or at any time during the hearing except while another proposal is being discussed. Preference shall be given to grouping like subjects together, and for moving items back to a later position on the agenda as opposed to moving items forward to an earlier position. A motion to revise the agenda order is subject to a 2/3 vote of those present and voting.
 - 5.4.5 **Reconsideration:** There shall be no reconsideration of a proposed code change after it has been voted on by the committee in accordance with Section 5.6; or, in the case of assembly consideration, there shall be no reconsideration of a proposed code change after it has been voted on by the assembly in accordance with Section 5.7.
 - 5.4.6 **Time Limits:** Time limits shall be established as part of the agenda for testimony on all proposed changes at the beginning of each hearing session. Each person requesting to testify on a change shall be given equal time. In the interest of time and fairness to all hearing participants, the Moderator shall have limited authority to modify time limitations on debate. The Moderator shall have the authority to adjust time limits as necessary in order to complete the hearing agenda.
 - 5.4.6.1 **Time Keeping:** Keeping of time for testimony by an individual shall be by an automatic timing device. Remaining time shall be evident to the person testifying. Interruptions during testimony shall not be tolerated. The Moderator shall maintain appropriate decorum during all testimony.
 - 5.4.6.2 **Proponent Testimony:** The Proponent is permitted to waive an initial statement. The Proponent shall be permitted to have the amount of time that would have been allocated during the initial testimony period plus the amount of time that would be allocated for rebuttal. Where the code change proposal is submitted by multiple proponents, this provision shall permit only one proponent of the joint submittal to be allotted additional time for rebuttal.
 - 5.4.7 **Points of Order:** Any person participating in the public hearing may challenge a procedural ruling of the Moderator or the Chairman. A majority vote of the eligible voters as determined in Section 5.7.4 shall determine the decision.
- 5.5 **Floor Discussion:** The Moderator shall place each code change proposal before the hearing for discussion by identifying the proposal and by regulating discussion as follows:
- 5.5.1 **Discussion Order:**
 1. *Proponents.* The Moderator shall begin by asking the proponent and then others in support of the proposal for their comments.
 2. *Opponents.* After discussion by those in support of a proposal, those opposed hereto, if any, shall have the opportunity to present their views.
 3. *Rebuttal in support.* Proponents shall then have the opportunity to rebut points raised by the opponents.
 4. *Rerebuttal in opposition.* Opponents shall then have the opportunity to respond to the proponent's rebuttal.
 - 5.5.2 **Modifications:** Modifications to proposals may be suggested from the floor by any person participating in the public hearing. The person proposing the modification is deemed to be the proponent of the modification.

5.5.2.1 Submission and Written Copies. All modifications must be written, unless determined by the Chairman to be either editorial or minor in nature. The modification proponent shall provide 20 copies to the Secretariat for distribution to the committee.

5.5.2.2 Criteria. The Chairman shall rule proposed modifications in or out of order before they are discussed on the floor. A proposed modification shall be ruled out of order if it:

1. is not legible, unless not required to be written in accordance with Section 5.5.2.1; or
2. changes the scope of the original proposal; or
3. is not readily understood to allow a proper assessment of its impact on the original proposal or the code.

The ruling of the Chairman on whether or not the modification is in or out of order shall be final and is not subject to a point of order in accordance with Section 5.4.7.

5.5.2.3 Testimony. When a modification is offered from the floor and ruled in order by the Chairman, a specific floor discussion on that modification is to commence in accordance with the procedures listed in Section 5.5.1.

5.6 Committee Action: Following the floor discussion of each code change proposal, one of the following motions shall be made and seconded by members of the committee.

1. Approve the code change proposal as submitted (AS) or
2. Approve the code change proposal as modified with specific modifications (AM), or
3. Disapprove the code change proposal (D)

Discussion on this motion shall be limited to Code Development Committee members. If a committee member proposes a modification which had not been proposed during floor discussion, the Chairman shall rule on the modification in accordance with Section 5.5.2.2. If a committee member raises a matter of issue, including a proposed modification, which has not been proposed or discussed during the floor discussion, the Moderator shall suspend the committee discussion and shall reopen the floor discussion for comments on the specific matter or issue. Upon receipt of all comments from the floor, the Moderator shall resume committee discussion.

The Code Development Committee shall vote on each motion with the majority dictating the committee's action. Committee action on each code change proposal shall be completed when one of the motions noted above has been approved. Each committee vote shall be supported by a reason.

The Code Development Committee shall maintain a record of its proceedings including the action on each code change proposal.

5.7 Assembly Consideration: At the conclusion of the committee's action on a code change proposal and before the next code change proposal is called to the floor, the Moderator shall ask for a motion from the public hearing attendees who may object to the committee's action. If a motion in accordance with Section 5.7.1 is not brought forward on the committee's action, the results of the public hearing shall be established by the committee's action. If a motion in accordance with Section 5.7.1 is brought forward and

is sustained in accordance with Section 5.7.3, both the committee's action and the assemblies' action shall be reported as the results of the public hearing. Where a motion is sustained in accordance with Section 5.7.3, such action shall be the initial motion considered at Final Action Consideration in accordance with Section 7.3.8.2.

5.7.1 Floor Motion: Any attendee may raise an objection to the committee's action in which case the attendee will be able to make a motion to:

1. Approve the code change proposal as submitted from the floor (ASF), or
2. Approve the code change proposal as modified from the floor (AMF) with a specific modification that has been previously offered from the floor and ruled in order by the Chairman during floor discussion (see Section 5.5.2) or has been offered by a member of the Committee and ruled in order by the Chairman during committee discussion (see Section 5.6), or
3. Disapprove the code change proposal from the floor (DF).

- 5.7.2 Discussion:** On receipt of a second to the floor motion, the Moderator shall place the motion before the assembly for a vote. No additional testimony shall be permitted.
- 5.7.3 Assembly Action:** The assembly action shall be in accordance with the following majorities based on the number of votes cast by eligible voters (See 5.7.4).

Committee Action	Desired Assembly Action		
	ASF	AMF	DF
AS	--	2/3 Majority	2/3 Majority
AM	2/3 Majority	2/3 Majority	2/3 Majority
D	2/3 Majority	2/3 Majority	--

- 5.7.4 Eligible Voters:** All members of ICC in attendance at the public hearing shall be eligible to vote on floor motions. Only one vote authorized for each eligible attendee. Code Development Committee members shall be eligible to vote on floor motions. Application, whether new or updated, for ICC membership must be received by the Code Council ten days prior to the commencement of the first day of the public hearing.

- 5.8 Report of the Public Hearing:** The results of the public hearing, including committee action and successful assembly action, shall be posted on the ICC website not less than 60 days prior to Final Action Consideration except as approved by the ICC Board.

6.0 Public Comments

- 6.1 Intent:** The public comment process gives attendees at the Final Action Hearing an opportunity to consider specific objections to the results of the public hearing and more thoughtfully prepare for the discussion for Final Action Consideration. The public comment process expedites the Final Action Consideration at the Final Action Hearing by limiting the items discussed to the following:
- 6.1.1** Consideration of items for which a public comment has been submitted; and
 - 6.1.2** Consideration of items which received a successful assembly action at the public hearing.
- 6.2 Deadline:** The deadline for receipt of a public comment to the results of the public hearing shall be announced at the public hearing but shall not be less than 30 days from the availability of the report of the results of the public hearing (see Section 5.8).
- 6.3 Withdrawal of Public Comment:** A public comment may be withdrawn by the public commenter at any time prior to Final Action Consideration of that comment. A withdrawn public comment shall not be subject to Final Action Consideration. If the only public comment to a code change proposal is withdrawn by the public commenter prior to the vote on the consent agenda in accordance with Section 7.3.4, the proposal shall be considered as part of the consent agenda. If the only public comment to a code change proposal is withdrawn by the public commenter after the vote on the consent agenda in accordance with Section 7.3.4, the proposal shall continue as part of the individual consent agenda in accordance with Section 7.3.5, however the public comment shall not be subject to Final Action Consideration.
- 6.4 Form and Content of Public Comments:** Any interested person, persons, or group may submit a public comment to the results of the public hearing which will be considered when in conformance to these requirements. Each public comment to a code change proposal shall be submitted separately and shall be complete in itself. Each public comment shall contain the following information:
- 6.4.1 Public comment:** Each public comment shall include the name, title, mailing address, telephone number and email address of the public commenter. If group, organization, or committee submits a public comment, an individual with prime responsibility shall be indicated. If a public comment is submitted on behalf a client, group, organization or committee, the name and mailing address of the client, group, organization or committee shall be indicated. The scope of the public comment shall be consistent with the scope of the original code change proposal, committee action or successful assembly action. Public comments which are determined as not within the scope of the code change proposal, committee action or successful assembly action shall be identified as such. The public commenter shall be notified that the public comment is considered an incomplete public comment in accordance with Section 6.5.1 and the public comment shall be held until the deficiencies are corrected. A copyright release in accordance with Section 3.3.4.5 shall be provided with the public comment.

- 6.4.2 Code Reference:** Each public comment shall include the code change proposal number and the results of the public hearing, including successful assembly actions, on the code change proposal to which the public comment is directed.
- 6.4.3 Multiple public comments to a code change proposal.** A proponent shall not submit multiple public comments to the same code change proposal. When a proponent submits multiple public comments to the same code change proposal, the public comments shall be considered as incomplete public comments and processed in accordance with Section 6.5.1. This restriction shall not apply to public comments that attempt to address differing subject matter within a code section.
- 6.4.4 Desired Final Action:** The public comment shall indicate the desired final action as one of the following:
1. Approve the code change proposal as submitted (AS), or
 2. Approve the code change proposal as modified (AM) by one or more specific modifications published in the Results of the Public Hearing or published in a public comment, or
 3. Disapprove the code change proposal (D)
- 6.4.5 Supporting Information:** The public comment shall include in a statement containing a reason and justification for the desired final action on the code change proposal. Reasons and justification which are reviewed in accordance with Section 6.4 and determined as not germane to the technical issues addressed in the code change proposal or committee action shall be identified as such. The public commenter shall be notified that the public comment is considered an incomplete public comment in accordance with Section 6.5.1 and the public comment shall be held until the deficiencies are corrected. The public commenter shall have the right to appeal this action in accordance with the policy of the ICC Board. A bibliography of any substantiating material submitted with a public comment shall be published with the public comment and the substantiating material shall be made available at the Final Action Hearing.
- 6.4.6 Number:** One copy of each public comment and one copy of all substantiating information shall be submitted. Additional copies may be requested when determined necessary by the Secretariat. A copy of the public comment in electronic form is preferred.

6.5 Review: The Secretariat shall be responsible for reviewing all submitted public comments from an editorial and technical viewpoint similar to the review of code change proposals (See Section 4.2).

6.5.1 Incomplete Public Comment: When a public comment is submitted with incorrect format, without the required information or judged as not in compliance with these Rules of Procedure, the public comment shall not be processed. The Secretariat shall notify the public commenter of the specific deficiencies and the public comment shall be held until the deficiencies are corrected, or the public comment shall be returned to the public commenter with instructions to correct the deficiencies with a final date set for receipt of the corrected public comment.

6.5.2 Duplications: On receipt of duplicate or parallel public comments, the Secretariat may consolidate such public comments for Final Action Consideration. Each public commenter shall be notified of this action when it occurs.

6.5.3 Deadline: Public comments received by the Secretariat after the deadline set for receipt shall not be published and shall not be considered as part of the Final Action Consideration.

6.6 Publication: The public hearing results on code change proposals that have not been public commented and the code change proposals with public commented public hearing results and successful assembly actions shall constitute the Final Action Agenda. The Final Action Agenda shall be posted on the ICC website at least 30 days prior to Final Action consideration.

7.0 Final Action Consideration

7.1 Intent: The purpose of Final Action Consideration is to make a final determination of all code change proposals which have been considered in a code development cycle by a vote cast by eligible voters (see Section 7.4).

7.2 Agenda: The final action consent agenda shall be comprised of proposals which have neither an assembly action nor public comment. The agenda for public testimony and individual consideration shall be comprised of proposals which have a successful assembly action or public comment (see Sections 5.7 and 6.0).

7.3 Procedure: *The Robert's Rules of Order* shall be the formal procedure for the conduct of the Final Action Consideration except as these Rules of Procedure may otherwise dictate.

- 7.3.1 Open Meetings:** Public hearings for Final Action Consideration are open meetings. Any interested person may attend and participate in the Floor Discussion.
- 7.3.2 Agenda Order:** The Secretariat shall publish an agenda for Final Action Consideration, placing individual code change proposals and public comments in a logical order to facilitate the hearing. The proponents or opponents of any proposal or public comment may move to revise the agenda order as the first order of business at the public hearing, or at any time during the hearing except while another proposal is being discussed. Preference shall be given to grouping like subjects together and for moving items back to a later position on the agenda as opposed to moving items forward to an earlier position. A motion to revise the agenda order is subject to a 2/3 vote of those present and voting.
- 7.3.3 Presentation of Material at the Public Hearing:** Information to be provided at the hearing shall be limited to verbal presentations. Audio-visual presentations are not permitted. Substantiating material submitted in accordance with Section 6.4.4 and other material submitted in response to a code change proposal or public comment shall be located in a designated area in the hearing room.
- 7.3.4 Final Action Consent Agenda:** The final action consent agenda (see Section 7.2) shall be placed before the assembly with a single motion for final action in accordance with the results of the public hearing. When the motion has been seconded, the vote shall be taken with no testimony being allowed. A simple majority (50% plus one) based on the number of votes cast by eligible voters shall decide the motion.
- 7.3.5 Individual Consideration Agenda:** Upon completion of the final action consent vote, all proposed changes not on the final action consent agenda shall be placed before the assembly for individual consideration of each item (see Section 7.2).
- 7.3.6 Reconsideration:** There shall be no reconsideration of a proposed code change after it has been voted on in accordance with Section 7.3.8.
- 7.3.7 Time Limits:** Time limits shall be established as part of the agenda for testimony on all proposed changes at the beginning of each hearing session. Each person requesting to testify on a change shall be given equal time. In the interest of time and fairness to all hearing participants, the Moderator shall have limited authority to modify time limitations on debate. The Moderator shall have the authority to adjust time limits as necessary in order to complete the hearing agenda.
- 7.3.7.1 Time Keeping:** Keeping of time for testimony by an individual shall be by an automatic timing device. Remaining time shall be evident to the person testifying. Interruptions during testimony shall not be tolerated. The Moderator shall maintain appropriate decorum during all testimony.
- 7.3.8 Discussion and Voting:** Discussion and voting on proposals being individually considered shall be in accordance with the following procedures:
- 7.3.8.1 Allowable Final Action Motions:** The only allowable motions for final action are Approval as Submitted, Approval as Modified by one or more modifications published in the Final Action Agenda, and Disapproval.
- 7.3.8.2 Initial Motion:** The Code Development Committee action shall be the initial motion considered, unless there was a successful assembly action in accordance with Section 5.7.3. If there was a successful assembly action, it shall be the initial motion considered. If the assembly action motion fails, the code development committee action shall become the next motion considered.
- 7.3.8.3 Motions for Modifications:** Whenever a motion under consideration is for Approval as Submitted or Approval as Modified, a subsequent motion and second for a modification published in the Final Action Agenda may be made (see Section 6.4.3). Each subsequent motion for modification, if any, shall be individually discussed and voted before returning to the main motion. A two-thirds majority based on the number of votes cast by eligible voters shall be required for a successful motion on all modifications.
- 7.3.8.4 Voting:** After dispensing with all motions for modifications, if any, and upon completion of discussion on the main motion, the Moderator shall then ask for the vote on the main motion. If the motion fails to receive the majority required in Section 7.5, the Moderator shall ask for a new motion.
- 7.3.8.5 Subsequent Motion:** If the initial motion is unsuccessful, a motion for one of the other allowable final actions shall be made (see Section 7.3.8.1) and dispensed with until a successful final action is achieved. If a successful final action is not achieved, Section 7.5.1 shall apply.

7.3.9 Proponent testimony: The Proponent of a public comment is permitted to waive an initial statement. The Proponent of the public comment shall be permitted to have the amount of time that would have been allocated during the initial testimony period plus the amount of time that would be allocated for rebuttal. Where a public comment is submitted by multiple proponents, this provision shall permit only one proponent of the joint submittal to waive an initial statement.

7.3.10 Points of Order: Any person participating in the public hearing may challenge a procedural ruling of the Moderator. A majority vote of the eligible voters as determined in Section 5.7.4 shall determine the decision.

7.4 Eligible voters: ICC Governmental Member Representatives and Honorary Members in attendance at the Final Action Hearing shall have one vote per eligible attendee on all International Codes. Applications, whether new or updated, for governmental member voting representative status must be received by the Code Council ten days prior to the commencement of the first day of the Final Action Hearing in order for any designated representative to be eligible to vote.

7.5 Majorities for Final Action: The required voting majority based on the number of votes cast of eligible voters shall be in accordance with the following table:

Public Hearing Action (see note)	Desired Final Action		
	AS	AM	D
AS	Simple Majority	2/3 Majority	Simple Majority
AM	2/3 Majority	Simple Majority to sustain the Public Hearing Action or; 2/3 Majority on additional modifications and 2/3 on overall AM	Simple Majority
D	2/3 Majority	2/3 Majority	Simple Majority

Note: The Public Hearing Action includes the committee action and successful assembly action.

7.5.1 Failure to Achieve Majority Vote: In the event that a code change proposal does not receive any of the required majorities for final action in Section 7.5, final action on the code change proposal in question shall be disapproval.

7.6 Publication: The Final action on all proposed code changes shall be published as soon as practicable after the determination of final action. The exact wording of any resulting text modifications shall be made available to any interested party.

8.0 Appeals

8.1 Right to Appeal: Any person may appeal an action or inaction in accordance with CP-1.

2009/2010 ICC CODE DEVELOPMENT CYCLE CROSS INDEX OF PROPOSED CODE CHANGES

Some of the proposed code changes include sections that are outside of the scope of the chapters or the code listed in the table of 2009/2010 Staff Secretaries on page ix. This is done in order to facilitate coordination among the International Codes which is one of the fundamental principles of the International Codes.

Listed in this cross index are proposed code changes that include sections of codes or codes other than those listed on page ix. For example, IBC Section 402.16.5 is proposed for revision in Part II of code change F58-09/10, which is to be heard by the IFC Committee. This section of the IBC is typically the responsibility of the IBC General Committee as listed in the table of 2009/2010 Staff Secretaries. It is therefore identified in this cross index. Another example is Section 905.4 of the International Fire Code. The International Fire Code is normally maintained by the IFC Committee, but Section 905.4 will be considered for revision in proposed code change G31-09/10 and will be placed on the IBC General Committee agenda. In some instances, there are other subsections that are revised by an identified code change that is not included in the cross index. For example, numerous sections in Chapter 10 of the International Fire Code would be revised by the proposed changes to Chapter 10 of the IBC. This was done to keep the cross index brief enough for easy reference.

This information is provided to assist users in locating all of the proposed code changes that would affect a certain section or chapter. For example, to find all of the proposed code changes that would affect Chapter 7 of the IBC, review the proposed code changes in the Volume 1 monograph for the IBC Fire Safety Committee (listed with a FS prefix) then review this cross reference for Chapter 7 of the IBC for proposed code changes published in other code change groups. While care has been taken to be accurate, there may be some omissions in this list.

Letter prefix: Each proposed change number has a letter prefix that will identify where the proposal is published. The letter designations for proposed changes and the corresponding publications are as follows:

PREFIX	PROPOSED CHANGE GROUP (see monograph table of contents for location)
ADM	Administrative
E	International Building Code - Means of Egress
EB	International Existing Building Code
EC	International Energy Conservation Code
F	International Fire Code
FG	International Fuel Gas Code
FS	International Building Code - Fire Safety
G	International Building Code - General
M	International Mechanical Code
PC	ICC Performance Code
P	International Plumbing Code
PSD	International Private Sewage Disposal Code
PM	International Property Maintenance Code
RB	International Residential Code - Building
RE	International Residential Code - Energy
RM	International Residential Code - Mechanical
RP	International Residential Code - Plumbing
S	International Building Code - Structural
WUIC	International Wildland-Urban Interface Code
Z	International Zoning Code

INTERNATIONAL BUILDING CODE	
Chapter 1	ADM1 Part I
101.2	ADM2
101.3	ADM3
102.4	ADM4 Part I
104.10.1(New)	ADM5
105.2	ADM6 Part I
105.2.4	ADM7 Part I
106.1	S55-09/10
107.2	ADM9 Part I
107.2.2	ADM10
107.2.3	ADM11
107.2.6	ADM12
108.1	ADM13
109.3.10.1	ADM14 Part I
110.3	ADM8 Part II
110.3.6	ADM23 Part I (Heard by IBC-FS Committee)
110.6	ADM15 Part II
113.2.1	ADM5
117 (New)	ADM16 Part I
R202	EB3 , EB4
202	G2 Part I– Heard by Structural
303.1	E140, E141
Table 307.1(1)	F186, F187
307.2	F186, F190, F196
307.4	F187
402.11	F58, Part II
402.12.1	F58, Part II
402.16.5	F58, Part II
403.2.3	E5 – Part I
403.2.3.1	E5 – Part I
403.2.3.2	E5 – Part I
403.3.1.1 (IFC 914.3.1.1.1)	E5 – Part II
403.5.1	E5 – Part I
403.5.4	E5 – Part I
406.2.2	E151 Part I
406.6.6.1	F178
406.6.6.1.1 (New)	F178
408.3.8	E5 – Part I
410.5.3.1 (New)	E5 – Part I
414.2.1	F189
414.2.2	F190
Table 414.2.2	F189
414.2.4	F189
414.7.2 (IFC 2705.4.4)	E5 – Part II
Table 415.8.2.1.1	F165
415.8.2.6	F162, Part I
415.8.3	F167
415.8.4.6.2 (IFC 1803.12.1.2)	E5 – Part II
415.8.11.2	F161
416	F155
501.2	F18
505.3	E6
505.4	E6

705.2	E5 – Part I, E137
705.11	G81
707.3.2	E5 – Part I
707.3.3 (New)	E5 – Part I
707.3.10 new	G81
707.3.10 (New)	E132
707.4	E5 – Part I
707.5.1	G178
707.5.1	E5 – Part I
707.6	E5 – Part I
707.7.1	E5 – Part I
708.1	E5 – Part I
708.2	E5 – Part I
708.3 (New)	E5 – Part I
708.6	E5 – Part I
708.14.1	G44 Part I
709.1	G82
709.3	G81
709.4	G81
709.5	E5 – Part I
710.5	G15, G21
712.4	G178
717.3.2	G81
717.4.2	G81, G82
712.4	E5 – Part I
Table 715.4	E5 – Part I
715.4.4	E5 – Part I
715.4.6.1	E5 – Part I
715.4.7.2	E5 – Part I
716.5.1	F162, Part II
716.5.2	E5 – Part I
Table 803.9	E5 – Part I
804.4	E5 – Part I
804.4.1	E5 – Part I
806.1	F57
901.2.1	F62
901.6.3	F193, Part II
907.5.2.3.4	E151 Part II
909.5 (IFC 909.5, IMC 513.5)	E5 – Part II
911.1.2	F22
911.1.5	F23, F24, F25
911.1.5	G44 Part II
1006.1	G21
1007.1	EB10
1008.1.9.6	G65
1009.7	G67 – Heard by MOE
1013.1 (New)	FS154
1013.8 (New)	FS154
1015.1 and Table 1015.1	G16
1015.6	G67 – Heard by MOE
1015.6.1	G67 – Heard by MOE
1015.7 new	G16
1021.2	G16, G20
Table 1021.2	G20
1022.1	G52
1022.1	G67 – Heard by MOE

IBC (continued)	
1103.2.12	G16
1106.3	G65
1106.4	G65
1107.5.2	G22, G23
1107.5.3	G20
1107.6.4.1	G21
1110.3	G177 – Heard by MOE
Table 1604.5	G65
1703.5.4 (New)	FS101
1704.16	F135
1704.16.1	F135
1704.16.2	F135
2303.3 (New)	FS133
2606.7	E5 – Part I
2702 (New)	F31
2702.2.21 (New)	F33
2902.4	E151 Part III
2902.1	P20
Table 2902.1	P21, P22, P23, P24
2902.2	P25
2902.2.1 (New)	P26
2902.3	P27
2902.4.1	P28
2902.3.5 (New)	P30
2902.5 (New)	P31
2902.3.2	P35
2902.1.3	P46
2902.3	P162
3001.3	E151 Part I
3003.3 (New)	F20, Part II
3007.4.1	E5 – Part I
3007.5	E5 – Part I
3008.11.1	E5 – Part I
3108.1	S85-09/10
3403.5 (New)	F114, Part II
3404.6	E20 Part I, E21 Part I
3404.7 (New)	F114, Part II
3405.2	EB6
3405.2.1	EB6
3405.3.1	EB8 , EB9
3408.4	S41-09/10
3411.1	EB11 , EB14
3411.1	E156 Part I
3411.4	EB10 , EB11 , EB14 , EB32
3411.4.1	EB10 , EB32
3411.4.2	EB10 , EB14 , EB32 , EB33
3411.5	EB10 , EB11
3411.6	EB10 , EB11 , EB14
3411.6	E151 Part I
3411.7	EB14
3411.7 (New)	EB11
3411.8	EB11
3411.8	E 152 Part I
3411.8 (New)	EB10
3411.8.1(New)	EB10
3411.8.5	EB11
3411.8.8	EB14

3411.8.9	EB11 , EB14
3411.8.15 (New)	E 152 Part I
3411.8.15.1 (New)	E 152 Part I
3411.8.15.2 (New)	E 152 Part I
3411.8.16 (New)	E 152 Part I
3411.9	EB10 , EB14
3412.2.5	EB14
3412.6.11	E20 Part I, E21 Part I
Table 3412.6.11(1)	E20 Part I, E21 Part I
Chapter 35	F58, Part II
Chapter 35	ADM39
K101.3	ADM3
Appendix I	G2 – Heard by IBC -S
Appendix L (New)	F236, Part II
Appendix L (New)	S108-09/10
INTERNATIONALENERGY CONSERVATION CODE	
Chapter 1	ADM1 Part III
101.3	ADM3, ADM24 (Heard by IECC Committee)
101.4.4	ADM27 (Heard by IECC Committee)
101.4.6	ADM25 (Heard by IECC Committee)
101.5.1	ADM17
101.5.2	ADM26 (Heard by IECC Committee)
102.1.1	ADM28 (Heard by IECC Committee) ADM31 (Heard by IECC Committee)
102.1.2	ADM29 (Heard by IECC Committee)
103.1	ADM17
103.2	ADM9 Part I
104.2	ADM15 Part I
106.1	ADM4
110	ADM16 Part I
Ch. 6	ADM39
INTERNATIONAL EXISTING BUILDING CODE	
Chapter 1	ADM1 Part II
101.2	ADM2
101.3	ADM3
Table 101.5.4.1	S41-09/10
101.5.4.2	S41-09/10
Table 101.5.4.2	S41-09/10
101.5.4.2	ADM32 (Heard by IBC-S Committee) ADM33 (Heard by IBC-S Committee)
102.4	ADM4
106.2.1	ADM9 Part I
107.1	ADM13
109.3.6(New)	ADM23
109.6	ADM15 Part I
118	ADM16 Part I

IEBC (continued)	
202	S91-09/10
301.1	G187
301.1.1	G188
301.2	G190 – Heard by IBC –S
301.2.1	G191 – Heard by IBC-S
301.2.3	G190 – Heard by IBC – S
301.3	G192 – Heard by IBC-S
302.4.1	G190 – Heard by IBC – S
302.5 (New)	F114, Part III
303.4.1	G190 – Heard by IBC-S
303.6	E20 Part I, E21 Part I
303.7 (New)	F114, Part III
304.1.1	G192 – Heard by IBC-S
304.2	G193, G194 – Both heard by IBC-S
304.2.1	G190, G193, G194 – All heard by IBC - S
304.2.2	G193, G194 – Both heard by IBC-S
304.2.3	G193, G194, G195 – All heard by IBC-S
304.3	G193 – Heard by IBC-S
304.3.1	G193 – Heard by IBC-S
304.3.2	G193 – Heard by IBC-S
304.4	G193, G194 – Both heard by IBC-S
304.5	G193, G196 – Both heard by IBC-S
307.4	G190, G197 – Both heard by IBC-S
307.4	S41-09/10
309.1	G198, G199
310.1	E156 Part I
310.6	E151 Part I
310.8	E152
310.8.8	G200 – Heard by MOE
310.8.15 (New)	E152
310.8.15.1 (New)	E152
310.8.15.2 (New)	E152
310.8.16 (New)	E152
605.1	E 151 Part IV, E152 Part II, E156 Part II
605.1.15 (New)	E152 Part II
605.1.15.1 (New)	E152 Part II
605.1.15.2 (New)	E152 Part II
605.1.16 (New)	E152 Part II
704.4.3	F114, Part III
907.3.1	S41-09/10
907.3.2	S41-09/10
1004.1	F114, Part III
1202.2	S146-09/10
1202.2.1	S146-09/10
1301.6.2.1	G201
1301.6.14	G202
1301.6.14.1	G202
1301.6.19	G203
1301.6.11	E20 Part I, E21 Part I
Table 1301.6.11(1)	E20 Part I, E21 Part I

1401.3.1 new	G184
1401.5 new	G185
Chapter 15	ADM39
A102.2	S41-09/10
INTERNATIONAL FIRE CODE	
Chapter 1	ADM1 Part IV
101.2	ADM19
101.3	ADM3
102.5	ADM20
102.7	ADM4
105.1.1	ADM21
105.4.2	ADM9 Part I
105.4.2.1	ADM10
105.4.3	ADM9 Part I
105.6.2	ADM34 (Heard by IFC Committee)
107.2.1	ADM35 (Heard by IFC Committee)
114 (New)	ADM16 Part I
202	
Def of Group A	G10, G11, G12, G13, G14
Def of Group B	G6, G15
Def of Group E	G16
Def of Group F	G18, G19
Def of Group I	G16, G20, G21, G22, G23, G24
Def of Group M	G25
Def of Group R	G20, G21, G22, G23, G26, G27, G28, G29
Def of Group S	G19
508.1.5 (IBC 911.1.5)	G44, Part II
603.4	M8 PII
607.4	G153, Part II
803.8	FS136 Part II
901.4.3 (New)	FS29
903.2.2	G15
903.2.3	G15
903.2.4.2 (new)	G19
903.2.6	G16, G20, G21
903.2.6.1	G21
903.2.8	G20
903.2.9.1	G19
903.3.1.3	G20
903.3.2	G20
904.5.2.3.3	G21
905.3.3.	G31
905.4	G31
907.2.2	G15
907.2.2.1	G15
907.2.6	G20
907.2.6.2	G20
907.5.2.3.4	E151 Part II
909.5 (IBC 909.5, IMC 513.5)	E5 – Part II
914.3.1.1.1 (IBC 403.3.1.1)	E5 – Part II

IFC (continued)	
914.6.1	G70 – Heard by IFC
914.8.2.2	G71 – Heard by IFC
Chapter 10 See IBC MOE changes	
1007.1	EB10
1030.4.1	E93 Part II
1404.5	G185 Part II
IFC 1803.12.1.2 (IBC 415.8.4.6.2)	E5 – Part II
2303.2	G64
IFC 2705.4.4 (IBC 414.7.2)	E5 – Part II
3904.1.2	G73 Part II – Heard by IFC
4604.7	E20 Part II, E21 Part II
Table 4604.7	E20 Part II, E21 Part II
Chapter 47	ADM39
INTERNATIONAL FUEL GAS CODE	
Chapter 1	ADM1 Part V
101.4	ADM3
102.8	ADM4
107.2	ADM8 Part I
111 (New)	ADM16 Part I
301.11	S92-09/10, Part III
306.5	M11, M12
306.5.1	M13
410.4 (New)	F148, Part II
Chapter 8	ADM39
INTERNATIONAL MECHANICAL CODE	
Chapter 1	ADM1 Part VI
102.8	ADM4
102.3	ADM36 (Heard by IMC Committee)
102.4	ADM37 (Heard by IMC Committee)
107.2	ADM8 Part I
202	FG14 PII
301.3 thru 301.5	FG14 PII
301.6	FG10 PI
301.13	S92-09/10, Part IV
307.3	FG11 PI
401.4	S92-09/10, Part IV
501.2.1	S92-09/10, Part IV
502.4	F43
502.5	F43
502.5.2	F43
502.8.4	F194
502.10.2	F162, Part I
510.7	F161, Part II
513.3	F135
513.10.2	F137
513.12	F138
513.12.1	F139
513.13.1	F140
602.4	S92-09/10, Part IV
603.13	S92-09/10, Part IV
606.2	F120

606.2.1 (New)	F120
606.2.2	F120
607.1	FS108, FS117
607.1.1	FS108, FS117
607.2	FS108, FS117
607.2.1	FS117
607.2.2	FS108, FS117
607.3.1	FS70, FS109
607.3.2.2	FS110
607.3.2.3	FS110
607.5	FS117
607.5.1	FS117
607.5.1	F162, Part II
607.5.1.1	FS117
607.5.2	FS117
607.5.2.1	FS117
607.5.3	FS114, FS117
607.5.4	FS117
607.5.5	FS111, FS112, FS113, FS117
607.5.6	FS117
607.5.7	FS117
607.6	FS117
607.6.1	FS115, FS117
607.6.2	FS117
607.6.2.1	FS117
607.6.3	FS116, FS117
607.7	FS117
918.6	FG32 PII
513.5 (IBC 909.5, IFC 909.5)	E5 – Part II
IMC 601.2 (IBC 1018.5, IFC 1018.5)	E116
1106.5	F39
1106.5.1	F39
1305.2.1	S92-09/10, Part IV
INTERNATIONAL PLUMBING CODE	
Chapter 1	ADM1 Part VII
101.3	ADM3
102.8	ADM4
107.2	ADM8 Part I
111 (New)	ADM16 Part I
202	FS124 Part II
309.2	S92-09/10, Part II
Table 403.1	G16, G20, G65
403.1	G16
403.2	G16
403.4	E151 Part III
1107.1	S2-09/10, Part I (Heard by IPC)
Chapter 13	ADM39
INT. PRIVATE SEWAGE DISPOSAL CODE	
Chapter 1	ADM1 Part IX
101.3	ADM3
102.10	ADM4
105.4	P1 Part II

IPSDC (continued)	
105.4.1	P1 Part II
105.4.2	P1 Part II
105.4.3	P1 Part II
105.4.4	P1 Part II
105.4.5	P1 Part II
105.4.6	P1 Part II
111 (New)	ADM 16 Part I
Section 304 (New)	P1 Part II
INTERNATIONAL PROPERTY MAINTENANCE CODE	
Chapter 1	ADM1 Part VIII
101.3	ADM3
102.3	ADM22
102.7	ADM4
108.1.3	ADM38 (Heard by IPMC Committee)
110.1	ADM38 (Heard by IPMC Committee)
113 (New)	ADM16 Part I
304.18.1	E60 Part II
606.1	G153 Part III
704.2	F114, Part I
704.3	F114, Part I
704.4	F114, Part II ; F115
Chapter 8	ADM39
INTERNATIONAL RESIDENTIAL CODE	Note: All Code Change Parts for IRC are heard by the applicable IRC Committee except ADM39
Chapter 1	ADM 1 Part XII
R101.2	G28 Part II
R101.4	ADM3 Part II
R102.4	ADM4 Part II
R105.2	ADM6 Part II
R105.2.4 (New)	ADM7 Part II
R106.1.1	ADM9 Part II
R109.1.6.1	ADM14 Part II
R109.4	ADM15 Part II
110.3	ADM8 Part I
R115 (New)	ADM16 Part II
R202	FS124 Part III
R202	FG14 PIII
R202	M1 PII
R202	E8 Part II, E100 Part II, E156 Part III, E194 Part II
R202	F108, Part II; F132, Part II
R202	P2 Part II, P92 Part II, P128 Part II, P152 Part II
R202	G2 Part II, G5 Part II, G28 Part II
301.13	S92-09/10, Part IV
Figure R301.2(2)	S97-09/10, Part II
R301.2.1.1	S87-09/10, Part II
Table R301.5	S57-09/10, Part II, S61-09/10, Part II, S62-09/10, Part II, S66-09/10, Part II

R302.1	FS155 Part II
R302.1.2	FS155 Part II
R302.6	G56 Part II
R302.11.1	FS118 Part II
R308.3.1	S219-09/10, Part II
R308.4	S218-09/10, Part II
R308.4.1 (New)	S218-09/10, Part II
R308.4.2 (New)	S218-09/10, Part II
R308.4.3 (New)	S218-09/10, Part II
R308.4.4 (New)	S218-09/10, Part II
R308.4.5 (New)	S218-09/10, Part II
R308.4.6 (New)	S218-09/10, Part II
R308.4.7 (New)	S218-09/10, Part II
R308.6.1	S144-09/10, Part II
R310.1	E150 Part II
R311.2	E60 Part III
R311.2.1 (New)	E60 Part III
R311.3.1	E58 Part II
R311.4	E122 Part II
R311.7.4	E70 Part II, E71 Part II, E72 Part II
R311.7.4.1	E74 Part II
R311.7.4.2	E74 Part II
R311.7.4.3	E75 Part II
R311.7.4.3.1 (New)	E75 Part II
R311.7.4.3.2 (New)	E75 Part II
R311.7.4.3.3 (New)	E75 Part II
R311.7.7.3	E97 Part II
R312.2	E100 Part II
R314.1	F108, Part II; F112, Part II
R314.2	F108, Part II
R314.3	F108, Part II; F115, Part II
R314.4	F108, Part II; F115, Part II
R314.5	F115, Part II
R314.5 (New)	F116, Part II
R314.5.1 (New)	F116, Part II
R314.5.2 (New)	F116, Part II
R314.5.3 (New)	F116, Part II
R315	F132, Part II
R316.4	FS160 Part II
R316.5.3	FS168 Part II, FS169 Part II
R316.5.4	FS168 Part II, FS169 Part II
R316.5.13 (New)	FS171 Part II
R316.7	FS176 Part II
R316.8	FS176 Part II
R317.3	S203-09/10, Part II
R317.3.1	S203-09/10, Part II
R317.3.2	S203-09/10, Part II
R317.3.3	S203-09/10, Part II
R317.3.4	S203-09/10, Part II
R317.4.1 (New)	S207-09/10, Part II
R317.4.2	S207-09/10, Part II
R320.2 (New)	E156 Part III
R402.2	S162-09/10, Part II
R403.3.4	FS176 Part II
R404.1.2.3.6.1	FS176 Part II
R503.2.1	S200-09/10, Part II
R503.2.1.1	S200-09/10, Part II

IRC (continued)	
Table R601.3.1	FS147 Part II
R602.3	S200-09/10, Part II
R602.9	S214-09/10, Part II
R604.1	S199-09/10, Part II
R606.1	S171-09/10, Part II
R606.1.1	S171-09/10, Part II
R606.12.1	S171-09/10, Part II
R606.12.3.1	S171-09/10, Part II
R702.2.1	S222-09/10, Part II
R702.2.2	S222-09/10, Part II
R702.3.1	S222-09/10, Part II
R702.4.2	S224-09/10, Part II
R703.1.1	FS140 Part II
R703.3	FS156 Part II
R703.4	FS156 Part II
R703.4	S199-09/10, Part II
Table R703.4	FS156 Part II
R703.5.1	FS156 Part II
R703.6.1	FS156 Part II
R703.6.3	S225-09/10, Part II
R703.7.4.1	FS156 Part II
R703.11.2	FS156 Part II
R703.11.2.1	FS156 Part II
R703.11.2.2	FS156 Part II
R703.11.2.3	FS156 Part II
R703.12	FS150 Part II, FS151 Part II
703.12.1	FS150 Part II, FS151 Part II
R802.1.3	S201-09/10, Part II
R802.1.3.1	S201-09/10, Part II
R802.1.3.2	S201-09/10, Part II
R802.1.3.3	S201-09/10, Part II
R803.2.1	S200-09/10, Part II
R806.1	G146 Part II
R806.2	G145 Part II
R903.2.2	S3-09/10, Part II
R903.4	S2-09/10, Part III (heard by IRC Plumbing)
R903.4.1	S2-09/10, Part III (heard by IRC Plumbing)
Table R905.2.4.1(2)	S14-09/10, Part II
R905.2.7.2	S15-09/10, Part II
R905.2.8.5 (New)	S16-09/10, Part II
R905.3.3.3	S15-09/10, Part II
R905.4.3.2 (New)	S15-09/10, Part II
R905.4.5.1 (New)	S17-09/10, Part II
R905.5.3.2 (New)	S15-09/10, Part II
R905.6.3.2 (New)	S15-09/10, Part II
R905.7.3.2 (New)	S15-09/10, Part II
R905.8.3.2 (New)	S15-09/10, Part II
R905.9.2	S18-09/10, Part II
R905.10.5.1 (New)	S15-09/10, Part II
R905.14.3	S20-09/10, Part II
Table R905.14.3 (New)	S20-09/10, Part II
R905.15	S21-09/10, Part II
R905.15.1	S21-09/10, Part II
R905.15.2	S21-09/10, Part II

R905.15.3	S21-09/10, Part II
R905.16 (New)	S22-09/10, Part III, S23-09/10, Part II
R905.16.1 (New)	S22-09/10, Part III, S23-09/10, Part II
R905.16.1.1 (New)	S23-09/10, Part II
R905.16.2 (New)	S22-09/10, Part III
R905.16.3 (New)	S22-09/10, Part III
R907.3	S30-09/10, Part II
R1003.9.1 (New)	S182-09/10, Part II
R1003.9.3 (New)	S182-09/10, Part II
R1003.11.1	M114 PII
R1005.7	M117 PII
R1004.2	M119 PII
T N1101.2	EC1 Part II
N1101.4.2.1(New)	EC2 Part II
N1101.6	EC4
Chapter 11	EC11 Part II, EC 13 Part II, EC16, Part II, EC19 Part II, EC25 Part II
N1101.2.2	EC21
N1101.7	EC28
N1101.9	EC22 Part II, EC23 Part II
N1102	EC26
N1102.1	EC31
N1103.2.1	EC26
Table N1102.1, Table N1102.1.2, Table1102.2.5	EC27, EC29, EC30, EC31, EC32, EC34, EC35, EC36, EC38, EC39, EC40, EC41, EC42, EC43, EC45, EC46, EC47, EC48, EC50, EC54, EC55, EC60, EC102 (All Part II)
Table N1102.1.4 (New) N1102.1.4(New)	EC56 Part II
N1102.2.2	EC59 Part II
N1102.2.2.1(New)	EC64 Part II
N1102.2.3 (New)	EC63 Part II
Table N1102.2.5	EC66 Part II
N1102.2.11	EC68 Part II
N1102.2.12(New)	EC69 Part II
Table N1102.4.2	EC26 Part II, EC59 Part II
Table N1102.1.4 (New) N1102.1.4(New)	EC57 Part II
N1102.3 (New)	EC71 Part II
N1102.3.3 (New)	EC72 Part II
N1102.3.3 (New)	EC73 Part II
N1102.3.3 (New)	EC74 Part II
N1102.3.4	EC76 Part II
N1102.3.5	EC68 Part II
N1102.3.6 (New)	EC96 Part II
N1102.3.7(New)	EC78 Part II
N1102.4.1	EC79, EC82, EC83
N1102.4.1.1(New)	EC79 Part II
N1102.4.1.2 (New)	EC79 Part II
N1102.4.2	EC81, EC82, EC83, EC86, EC90

IRC (continued)	
N1102.4.2.1.1 (New)	EC80 Part II
N1102.4.2.1.1 (New)	EC87 Part II
N1102.4.3	EC79 Part II, EC89 Part II
N1102.4.4	EC91 Part II
N1102.4.5	EC92 Part II
N1102.4.6	EC84
N1103.1	EC100 Part II
N1103.1.1	EC101 Part II
N1103.1.3 (New)	EC100 Part II
N1103.2.1	EC103 Part II
N1103.2.2	EC103, EC104, EC107 (All Part II)
N1103	
N1103.2.3	EC103 Part II, EC109 Part II,
N1103.3	EC117 Part II
N1103.3	EC123 Part II
N1103.4	EC115 Part II, EC116
N1103.4 (New)	EC114 Part II
N1103.4 (New)	EC118 Part II
N1103.4.1	EC112 Part II
N1103.4.2	EC112 Part II
N1103.5	EC79 Part II, EC131 Part II
N1103.5 (New)	EC119 Part II
N1103.5.1	EC99 Part II
N1103.6	EC120 Part II
T N1103.6 (New)	EC121 Part II
N1103.8	EC124 Part II
N1103.9	EC125 Part II
N1103.10 (New)	EC126 Part II
N1104 (New)	EC131 Part II
N1104.1	EC127, EC129, EC130 (All Part II)
N1104.1.1	EC18
M1301.2 thru M1301.5	FG14 PIII
M1303.1	M6 PII
M1303.1	FG10 PIII
M1307.3, P2801.6	M10 PII
M1401.1	M9 PII
M1407.1	M121 PII
M1411.5	FG11 PIII
M1411.6	M130 PII, M131 PII
M1411.6.1	M133 PII
M1413.1	M126 PII
M1413.2	M126 PII
M1502.4.1	M35 PII, M36 PII
M1502.4.2	M35 PII
M1502.4.4.1	M35 PII
M1502.4.4	M38 PII, M39 PII, M40 PII
M1502.4.4.2	M38 PII
M1502.4.4.3	M39 PII, M40 PII
M1503.1	M45 PII
M1503.2	M46 PII
M1506.1	M31 PII
M1601.1.1	M97 PII
Table M1601.1.1(2)	M98 PII

M1601.1.2	M102 PII, M103 PII
M1601.4.1	M105 PII
M1601.4	M110 PII
M1601.3	M111 PII, M112 PII
M1602.2	FG32 PIII
M2005.1	M127 PII
M2001.1.1	M128 PII
Table M2101.1	M140 PII, M141 PII, M142 PII
M2104.5	M148 PII
M2201.5	M151 PII
M2201.5	M151 PII
M2204.2	M152 PII
P2503.6	P18 Part II
P2503.8.2	P19 Part II, P106 Part II
P2601.2	P152 Part II
P2603.3	P8 Part II
P2603.4	P16 Part II
P2603.5	P10 Part II
Table P2605.1	P70 Part II
P2608.1	P7 Part II
P2608.4	P7 Part II
Table P2608.4	P7 Part II
Table P2701.1	P37 Part II
P2706.1	P121 Part II
P2708.1.1	P52 Part II
P2708.4 (New)	P53 Part II
P2709.2.1	P54 PartII
P2709.2.2	P54 PartII
P2709.2.4 (New)	P55 PartII
P2713.1	P40 Part II, P41 Part II
P2721.2	P42 Part II
P2722.5 (New)	P60 Part II
P2724.1 (New)	P61 Part II
P2803.6	P62 Part II
P2803.6 (New)	P63 Part II
P2803.6.1	P64 Part II
P2801.1.2	EC122 Part II
P2801.5	P65 Part II. P66 Part II P67 Part II
P2801.5.1	P67 Part II
P2801.5.3 (New)	P158 Part II
P2901.1	P87 Part II
P2902.1	P102 Part II
Table P2902.3	P83 Part II, P93 Part II
P2902.3.2	P93 Part II
P2902.3.3	P103 Part II
P2902.3.4	P96 Part II, P104 Part II
P2902.3.5	P95 Part II
P2902.3.6	P94 Part II
P2902.4	P94 Part II
P2902.4.2	P94 Part II
P2902.4.3	P86 Part II
P2902.5.1	P103 Part II
P2902.5.2	P154 Part II, P160 Part II
P2902.5.3	P100 Part II

IRC (continued)	
P2902.5.4	P99 Part II
P2902.5.4.1	P99 Part II
P2902.5.5	P94 Part II
P2902.6	P90 Part II
P2903.3.1	P157 Part II
P2903.5	P72 Part II
P2503.5.1	P156 Part II
Table P2903.6(1)	P153 Part II
P2903.9.5	P86 Part II
P2903.11 (New)	P75 Part II
P2904.3.1	P70 Part II
P2904.4.3	P94 Part II
Table P2904.6.2(8)	P70 Part II
Table P2904.6.2(9)	P70 Part II
P2905.4	P69 Part II
Table P2905.4	P68 Part II, P70 Part II
Table P2905.5	P70 Part II, P71 Part II
Table P2905.6	P70 Part II
P2905.9.1.2	P84 Part II
P2905.19 (New)	P70 Part II, P73 Part II
P2905.19.1(New)	P70 Part II
P2905.19.2 (New)	P70 Part II
P2908.1	P108 Part II
P2908.2	P108 Part II
P3001.4 (New)	P109 Part II
P3002.3.1	P111 Part II
P3003.9.2	P110 Part II
P3003.14.2	P110 Part II
P3003.19	P36 Part II
P3007.3.2.1 (New)	P114 Part II
P3007.3.3 (New)	P115 Part II
P3007.3.3.1 (New)	P115 Part II
P3007.3.3.2 (New)	P115 Part II
P3007.3.5	P116 Part II
P3009 (New)	P152 Part II
P3103.4	P124 Part II
P3103.5	P159 Part II
P3111.2	P128 Part II
P3111.3	P127 Part II
P3113.4.1	P131 Part II
P3201.5	P135 Part II
P3201.2	P136 Part II
Chapter 44	P60 Part II, P68 Part II, P69 Part II, P70 Part II, P71 Part II, P73 Part II, P83 Part II, P106 Part II, P108 Part II, P135 Part II, P136 Part II, P157 Part II
Chapter 44	F108, Part II; F132, Part II
Chapter 44	ADM39
Appendix H	G2 Part II
Appendix K	G147 Part II
Appendix L	G204 Part II

INT. WILDLAND-URBAN INTERFACE CODE	
Chapter 1	ADM1 Part X
101.3	ADM3
102.4	ADM4
115 (New)	ADM16 Part I
Chapter 15	ADM39
INTERNATIONAL ZONING CODE	
Chapter 1	ADM1 Part XI
101.2	ADM3
112 (New)	ADM16 Part I
Chapter 14	ADM39

2009/2010 ICC CODE DEVELOPMENT HEARING SCHEDULE

October 24 – November 11, 2009

Hilton Baltimore

Unless noted by “Start no earlier than X am/pm,” each Code Committee will begin immediately upon completion of the hearings for the prior Committee. Thus the actual start times for the various Code Committees are tentative. The hearing volume is higher than previous cycles. The schedule anticipates that the hearings will finish by the times noted as “Finish” for each track and each week.

CODE DEVELOPMENT HEARINGS: OCTOBER 24 - 31

	Saturday October 24	Sunday October 25	Monday October 26	Tuesday October 27	Wednesday October 28	Thursday October 29	Friday October 30	Saturday October 31
TRACK 1	Start 8 am IWUIC IFC End 8 pm	Start 10 am IFC End 8 pm	Start 8 am IFC IRC-Energy (Start no earlier than 1 pm) End 8 pm	Start 8 am IRC – Energy End 8 pm	Start 8 am IRC-Building (Start no earlier than 8 am) End 8 pm	Start 8 am IRC- Building End 8 pm	Start 8 am IRC – Building Admin (Start no earlier than 3 pm) End 8 pm	Start 8 am Admin Finish 3 pm
	Start 8 am IBC- Structural End 8 pm	Start 10 am IBC- Structural End 8 pm	Start 8 am IBC- Structural End 8 pm	Start 8 am IBC- Structural End 8 pm	Start 8 am IECC (Start no earlier than 8 am) End 8 pm	Start 8 am IECC End 8 pm	Start 8 am IECC End 8 pm	Start 8 am IECC Finish 8 pm

ANNUAL CONFERENCE: NOVEMBER 1 - 4

CODE DEVELOPMENT HEARINGS: NOVEMBER 4 - 11

	Wednesday November 4	Thursday November 5	Friday November 6	Saturday November 7	Sunday November 8	Monday November 9	Tuesday November 10	Wednesday November 11
TRACK 1	Start 8 am IPM/ZC IEBC IBC-Fire Safety End 5 pm	Start 8 am IBC-Fire Safety End 8 pm	Start 8 am IBC – Fire Safety IBC – General (Start no earlier than 3 pm) End 8 pm	Start 8 am IBC - General End 8 pm	Start 10 am IBC – General IBC – Egress (Start no earlier than 3 pm) End 8 pm	Start 8 am IBC - Egress End 8 pm	Start 8 am IBC - Egress End 8 pm	Start 8 am IBC - Egress Finish 12 pm
	Start 8 am IPC/IPSDC End 5 pm	Start 8 am IPC/IPSDC End 9 pm	Start 8 am IMC (Start no earlier than 8 am) End 9 pm	Start 8 am IMC IRC- Plumbing/ Mechanical (Start no earlier than 1 pm) End 9 pm	Start 10 am IRC – Plumbing/ Mechanical End 9 pm	Start 8 am IRC – Plumbing/ Mechanical IFGC (Start no earlier than 8 am) Finish 9 pm	NO HEARINGS TRACK 2 COMPLETED	

Notes:

- Hearing times may be modified at the discretion of the Chairman. Breaks will be announced.
- Proposed code changes submitted to the International Wildland-Urban Interface Code (IWUIC) to be heard by the IFC Committee.
- Proposed code changes submitted to the International Zoning (Z) and Property Maintenance (PM) Codes to be heard by the IPM/Z Committee.
- “Admin” is a new code committee who will hear changes that affect coordination of Chapter 1 of all the I-Codes, except the IRC, and referenced standards updates.

2009/2010 PROPOSED CHANGES TO THE INTERNATIONAL CODES

CODE	PAGE
Administrative Provisions (All Codes)	ADM1
International Building Code	
Fire Safety	IBC-FS1
General	IBC-G1
Means of Egress	IBC-E1
Structural	IBC-S1
International Energy Conservation Code.....	EC1
International Existing Building Code	EB1
International Fuel Gas Code.....	FG1
International Fire Code	F1
International Mechanical Code	M1
International Plumbing Code	P1
International Private Sewage Disposal Code	PSD1
International Property Maintenance Code	PM1
International Residential Code	
Building/Energy	IRC-RB1
Plumbing	IRC-RP1
Mechanical	IRC-RM1
International Wildland-Urban Interface Code (To be heard by the IFC Committee).....	WUIC1
International Zoning Code (To be heard by the IPM/IZC Committee)	Z1



Registration Delegate

2009 Annual Conference and Code Development Hearings
Hearings: October 24–31 and November 4–11
Hilton Baltimore
Conference: November 1–4
Baltimore Convention Center

FIRST NAME AND M.I. _____ LAST NAME/SURNAME _____

JOB TITLE _____

JURISDICTION/ORGANIZATION _____

MAILING ADDRESS _____

CITY _____ STATE/PROVINCE _____ ZIP/POSTAL CODE _____

COUNTRY _____ E-MAIL (MUST PROVIDE TO RECEIVE CONFIRMATION) _____

PHONE (SPECIFY COUNTRY AND CITY CODE IF OUTSIDE THE U.S.) _____ FAX (SPECIFY COUNTRY AND CITY CODE IF OUTSIDE THE U.S.) _____

Are you an ICC Member? NO YES, my ICC Membership Number is: _____ Check here if this is your first ICC Conference.

Type of Registration	ICC Member BEFORE SEPTEMBER 1	Nonmember	ICC Member AFTER SEPTEMBER 1	Nonmember
<input type="checkbox"/> Full Conference Registration (includes all business, education and social functions)	\$495*	\$625*	\$560*	\$685*
<input type="checkbox"/> Code Development Hearings only (Registration is required to verify voting status)	FREE Registration		FREE Registration	
<input type="checkbox"/> One-Day Education	\$125	\$160	\$160	\$190
<input type="checkbox"/> Monday, November 2 <input type="checkbox"/> Tuesday, November 3				
<input type="checkbox"/> Golf Tournament (per person)** Handicap _____	\$75	\$75	\$125	\$125
<input type="checkbox"/> Golf Club Rental**				
<input type="checkbox"/> Men's <input type="checkbox"/> Women's <input type="checkbox"/> Left <input type="checkbox"/> Right	\$25	\$25	\$25	\$25
All fees are in U.S. dollars.				TOTAL \$ _____



Payment Options:

- BILL ME (ICC MEMBERS ONLY)
- CHECK (PAYABLE TO ICC)
- VISA MASTERCARD
- AMERICAN EXPRESS

SIGNATURE _____

CREDIT CARD NUMBER _____ EXP. DATE _____

The Code Council reserves the right to photograph or videotape events for promotional purposes. Your registration serves as permission for ICC to copyright, publish and use your likeness in print, online or in other media. If you do not wish to be photographed or videotaped, please tell the camera operator.

Cancellation Policy: All cancellation requests must be received in writing. Cancellations received prior to September 1 will receive a full refund. Requests received between September 2–October 5 will be refunded, less a \$50 administrative charge. Cancellations received after October 5 will not be eligible for a refund.

*Take \$10 off when you register online.

**Payment is required with registration.

TO ATTEND EDUCATION SESSIONS, PLEASE COMPLETE THE EDUCATION PROGRAM FORM ON REVERSE.

Save \$10 When You Register Online

Register online: www.iccsafe.org/conference

Fax to: (708) 799-2307

Mail to: 2009 ICC Annual Conference
International Code Council
4051 W. Flossmoor Road
Country Club Hills, IL 60478

Phone registrations are not accepted.
Please do not fax AND mail your registration.

Lodging information available online.

If you have any questions, please call
1-888-ICC-SAFE, x4226 or x4229.

REQUIRED INFORMATION FOR EDUCATION PROGRAM

Last Name _____ First Name _____

SESSION SELECTION

If you are registering for the full conference, please enter a session number for each time slot.

If you are registering for one day of education only, please check the day you will be attending and enter your session selection number.

Monday, November 2

1:15 pm–4:15 pm

Session selection: # _____

Tuesday, November 3

1:15 pm–4:15 pm

Session selection: # _____

EARN CEUs

Earn continuing education recognition for attending sessions at the Conference. Indicate your choice(s) and provide your license or credential number (ID number) for each:

ALABAMA

- Board of Heating & Air Conditioning Contractors
ID Number _____

CALIFORNIA

- Council for Interior Design Certification/CCIDC
ID Number _____

CONNECTICUT

- Department of Public Safety, Office of Education & Data Management
ID Number _____

FLORIDA

- Building Code Administrators & Inspectors Board
ID Number _____
- Florida Professional Engineers Board
ID Number _____

GEORGIA

- Fire Fighter Standards and Training Council
ID Number _____

KANSAS

- Johnson County Contractor Licensing
ID Number _____

KENTUCKY

- Division of Building Code Enforcement, Department of Housing, Buildings, & Construction
ID Number _____

MAINE

- State Planning Office
ID Number _____

MASSACHUSETTS

- Board of Building Regulations and Standards
ID Number _____

MARYLAND

- Hartford County Department of Inspections, License & Permits, Building Services
ID Number _____

MICHIGAN

- Office of Fire Safety
ID Number _____
- Bureau of Construction Codes
ID Number _____

MISSOURI

- Board of Professional Registration – APELSA
ID Number _____

NEW JERSEY

- Department of Community Affairs, Division of Codes and Standards
ID Number _____
- Department of Community Affairs, Division of Fire Safety
ID Number _____

NEW YORK

- Department of State, Codes Division
Requires Social Security # _____
ID Number _____
- Department of State, Office of Fire Prevention
Requires Social Security # _____
FDID #/City Code _____
County Code _____
ID Number _____

NORTH CAROLINA

- Code Officials Qualification Board
Requires Driver's License # _____
ID Number _____

OHIO

- Ohio Department of Commerce, Board of Building Standards
ID Number _____
- Ohio Department of Commerce, Division of Industrial Compliance, Plumbing Section
ID Number _____

OKLAHOMA

- Construction Industries Board, Inspector Examining Committee
ID Number _____

PENNSYLVANIA

- Department of Labor and Industry
ID Number _____

RHODE ISLAND

- State Building Code Commission
ID Number _____

SOUTH CAROLINA

- Department of Labor, Licensing and Regulation Board of Building Codes Council
ID Number _____

TENNESSEE

- Commerce and Insurance, Fire Prevention Division (aka State Fire Marshal's Office)
ID Number _____

TEXAS

- Department of Licensing and Regulation, Electrical Safety and Licensing Advisory Board
ID Number _____

UTAH

- Division of Occupational and Professional Licensing, Contractor Licensing
ID Number _____

WISCONSIN

- Safety and Buildings Division
ID Number _____

AMERICAN INSTITUTE OF ARCHITECTS

ID Number _____

AMERICAN SOCIETY OF HOME INSPECTORS

ID Number _____

INTERNATIONAL CODE COUNCIL

ID Number _____

OTHER

ID Number _____

Many professional organizations, boards, and state agencies recognize ICC educational offerings. If you do not find your professional organization or agency listed above, you may still be able to earn continuing education credit by attending these educational sessions. To find out if a specific ICC offering has been recognized by a specific board/agency for continuing education credit, contact the applicable agency/board. ICC cannot guarantee that a specific professional board, organization or agency will recognize an ICC educational offering.

2009/2010 PROPOSED CHANGES TO THE INTERNATIONAL BUILDING CODE C MEANS OF EGRESS

MEANS OF EGRESS CODE COMMITTEE

Stephen Thomas, CBO - Chair

President
Colorado Code Consulting
Denver, CO

Jim Budzinski – Vice Chair

Fire Chief (Retired)
Tamarac, FL

Bart Alspaugh, MCP

Building Inspector II
City of Lake Saint Louis
Lake St. Louis, MO

Jason Averill

Group Leader
National Institute of Standards and Technology
Gaithersburg, MD

Tom Barrs

Senior Plans Examiner
City of Scottsdale
Scottsdale, AZ

Neil Burning, CBO

Manager, Plans Examination
Clark County Development Services-Bldg Div.
Las Vegas, NV

James Dawson

Fire Marshal
Chesterfield County Fire and EMS
Chesterfield, VA

David Frable

Senior Fire Protection Engineer
U.S. General Services Administration,
Bldg Services
Geneva, IL

Jeffrey Heiss

Construction Official
Township of Warren
Warren, NJ

James Hodgens

Deputy Chief
New York City Fire Department
Brooklyn, NY

Gary Lampella

Building Official
City of Redmond
Redmond, OR

Larry Lehman

Building Division Chief
State of Michigan
Department of Energy, Labor & Economic
Growth
Bureau of Construction Codes
Lansing, MI

Paul Martin

Rep: National Association of State Fire Marshals
Acting Chief - Bureau of Fire Prevention
New York State Office of Fire Prevention and
Control
Albany, NY

Brad Schiffer, AIA

Architect
Brad Schiffer/TAXIS Inc.
Naples, FL

John Stovall

Rep: National Association of Home Builders
NSArchitects
Rockville, MD

Staff Secretariat:

Kimberly Paarlberg, RA
Senior Staff Architect
International Code Council

TENTATIVE ORDER OF DISCUSSION

2009/2010 PROPOSED CHANGES TO THE INTERNATIONAL BUILDING CODE MEANS OF EGRESS

The following is the tentative order in which the proposed changes to the code will be discussed at the public hearings. Proposed changes which impact the same subject have been grouped to permit consideration in consecutive changes.

Proposed change numbers that are indented are those which are being heard out of numerical order. Indentation **does not** necessarily indicate that one change is related to another. Proposed changes may be grouped for purposes of discussion at the hearing at the discretion of the chair. Note that some AIBC-E® code change proposals are not included on this list, as they are being heard by other committees. Please consult the Cross Index of Proposed Changes.

E1-09/10	E46-09/10	E91-09/10	G170-09/10
E2-09/10	E47-09/10	E92-09/10	G171-09/10
E3-09/10	E48-09/10	E93-09/10, Part I	G172-09/10
E4-09/10	E49-09/10	E93-09/10, Part II	G173-09/10
E194-09/10, Part I	E50-09/10	E94-09/10	G174-09/10
E7-09/10	E51-09/10	E95-09/10	G175-09/10
E8-09/10 Part I	E52-09/10	E96-09/10	G176-09/10
G79-09/10	E53-09/10	E97-09/10, Part I	G177-09/10
G95-09/10	E54-09/10	E98-09/10	E119-09/10
E9-09/10	E55-09/10	E99-09/10	E120-09/10
E10-09/10	E56-09/10	E100-09/10, Part I	E121-09/10
E11-09/10	E57-09/10	E101-09/10	E122-09/10, Part I
E12-09/10	E58-09/10, Part I	E102-09/10	E123-09/10
E13-09/10	E59-09/10	E103-09/10	G52-09/10
E14-09/10	E60-09/10, Part I	E104-09/10	E124-09/10
E15-09/10	E60-09/10, Part II	E105-09/10	E125-09/10
E16-09/10	E61-09/10	E106-09/10	E126-09/10
E17-09/10	E62-09/10	E6-09/10	E127-09/10
E18-09/10	E63-09/10	E107-09/10	E128-09/10
E19-09/10	E64-09/10	G67-09/10	E129-09/10
E20-09/10, Part I	E65-09/10	E108-09/10	E130-09/10
E20-09/10, Part II	E66-09/10	E109-09/10	E131-09/10
E21-09/10, Part I	E5-09/10, Part I	E110-09/10	E132-09/10
E21-09/10, Part II	E5-09/10, Part II	E111-09/10	E133-09/10
E22-09/10	E67-09/10	E112-09/10	E134-09/10
E23-09/10	E68-09/10	E113-09/10	E135-09/10
E24-09/10	E69-09/10	E114-09/10	E136-09/10
E25-09/10	E70-09/10, Part I	E115-09/10	E137-09/10
E26-09/10	E71-09/10, Part I	E116-09/10	E138-09/10
E27-09/10	E72-09/10, Part I	E117-09/10	E139-09/10
E28-09/10	E73-09/10	E118-09/10	E140-09/10
E29-09/10	E74-09/10, Part I	G46-09/10	E141-09/10
E30-09/10	E75-09/10, Part I	G47-09/10	E142-09/10
E31-09/10	E76-09/10	G48-09/10	E143-09/10
E32-09/10	E77-09/10	G49-09/10	E144-09/10
E33-09/10	E78-09/10	G157-09/10	E145-09/10
E34-09/10	E79-09/10	G158-09/10	E146-09/10
E35-09/10	E80-09/10	G159-09/10	E147-09/10
E36-09/10	E81-09/10	G160-09/10	E148-09/10
E37-09/10	E82-09/10	G161-09/10	E149-09/10
E38-09/10	E83-09/10	G162-09/10	E150-09/10, Part I
E39-09/10	E84-09/10	G163-09/10	E151-09/10, Part I
E40-09/10	E85-09/10	G164-09/10	E151-09/10, Part II
E41-09/10	E86-09/10	G165-09/10	E151-09/10, Part III
E42-09/10	E87-09/10	G166-09/10	E151-09/10, Part IV
E43-09/10	E88-09/10	G167-09/10	E152-09/10, Part I
E44-09/10	E89-09/10	G168-09/10	E152-09/10, Part II
E45-09/10	E90-09/10	G169-09/10	E153-09/10

E154-09/10
E155-09/10
E156-09/10, Part I
E156-09/10, Part II
E157-09/10
E158-09/10
E159-09/10
E160-09/10
E161-09/10
E162-09/10
E163-09/10
E164-09/10
E165-09/10
E166-09/10
E167-09/10
E168-09/10
E169-09/10
E170-09/10
 G200-09/10
E171-09/10
E172-09/10
E173-09/10
E174-09/10
E175-09/10
E176-09/10
E178-09/10
E179-09/10
E180-09/10
E181-09/10
E182-09/10
E183-09/10
E184-09/10
E185-09/10
E186-09/10
E187-09/10
E188-09/10
E189-09/10
E190-09/10
E191-09/10
E192-09/10
E193-09/10

E1-09/10

1001.4 (New) (IFC [B] 1001.4 (New))

Proponent: Paul K. Heilstedt, PE, FAIA, Chair, representing ICC Code Technology Committee (CTC)

Add new text as follows:

1001.4 Fire safety and evacuation plans: Fire safety and evacuation plans shall be provided for all occupancies and buildings where required by the *International Fire Code*. Such fire safety and evacuation plans shall comply with the applicable provisions of Sections 401.2 and 404 of the *International Fire Code*.

Reason: The ICC Board established the ICC Code Technology Committee (CTC) as the venue to discuss contemporary code issues in a committee setting which provides the necessary time and flexibility to allow for full participation and input by any interested party. The code issues are assigned to the CTC by the ICC Board as "areas of study". Information on the CTC, including: meeting agendas; minutes; reports; resource documents; presentations; and all other materials developed in conjunction with the CTC effort can be downloaded from the following website: <http://www.iccsafe.org/cs/cc/ctc/index.html>. Since its inception in April/2005, the CTC has held seventeen meetings - all open to the public.

This proposed change is a result of the CTC's investigation of the area of study entitled "Review of NIST WTC Recommendations". The scope of the activity is noted as:

Review the recommendations issued by NIST in its report entitled "Final Report on the Collapse of the World Trade Center Towers", issued September 2005, for applicability to the building environment as regulated by the I-Codes. To evaluate the necessity of developing code changes in response to the NIST report.

This proposal is similar to E3-07/08 last cycle. However, based on fire service input, it has been expanded to include the reference to Section 401.2 of the IFC which states:

401.2 Approval. Where required by this code, fire safety plans, emergency procedures and employee traing programs shall be approved by the fire code official.

This added reference identifies the scope of responsibility of the evaluation of the plans.

The purpose of this code change proposal is to provide consistent requirements for jurisdictions regarding requirements for fire safety and evacuation plans. We feel fire safety and evacuation plans are important issues that impact occupant egress during an emergency and therefore meets the intent of the IBC and needs to be addressed. In addition, many jurisdictions across the country currently have adopted the IBC, however many of these same jurisdictions have not adopted the IFC. This reference will ensure that at least the fire safety and evacuation plans of the IFC are adopted by reference. Enforcement of the provisions is not an issue based on the reference to Section 401.2. The provisions are clearly within the scope of the IFC.

Cost Impact: The code change proposal will not increase the cost of construction.

Public Hearing: Committee:	AS	AM	D
Assembly:	ASF	AMF	DF

ICCFILENAME:Heilstedt-E2-1001.4

E2-09/10

1002.1 (IFC [B] 1002.1)

Proponent: Gregory R. Keith, Professional heuristic Development, representing The Boeing Company

Revise as follows:

1002.1 (IFC [B] 1002.1) Definitions. The following words and terms shall, for the purposes of this chapter and as used elsewhere in this code, have the meanings shown herein.

CORRIDOR. An enclosed exit access component that defines and provides a path of egress travel ~~to an exit~~.

Reason: The current definition of "CORRIDOR" is somewhat misleading. Obviously, there are two types of corridors: Fire-resistance rated and non-fire-resistance rated. Section 1018.6 states, "Fire-resistance-rated corridors shall be continuous from the point of entry to an exit..." This provision supports the philosophy that once a given level of protection is achieved, such level of protection shall not be reduced until arrival at the exit discharge. With the non-fire-resistance rated corridor, however, there is no inherent level of protection. It is not uncommon in building design for non-rated corridors to connect open office areas without leading to an exit. The proposed language will correlate with the definition of 'aisle' in declaring that unprotected exit access components provide a path of egress travel, but not necessarily directly to an exit. This proposal eliminates potential confusion created by the current definition and lets the technical requirements of Section 1018.6 stand on their own merit. Approval of this proposal will resolve a potential conflict in stated intent for commonly used corridor provisions.

Cost Impact: The code change proposal will not increase the cost of construction.

Public Hearing: Committee:	AS	AM	D
Assembly:	ASF	AMF	DF

ICCFILENAME:Keith-E2-1002.1-Corridor

E3-09/10

1002.1 (IFC [B] 1002.1)

Proponent: David S. Collins, FAIA, The Preview Group, Inc., representing The American Institute of Architects

Revise as follows:

1002.1 (IFC [B] 1002.1) Definitions. The following words and terms shall, for the purposes of this chapter and as used elsewhere in this code, have the meanings shown herein.

EXIT. That portion of a means of egress system ~~which is separated from other interior spaces of a building or structure by fire-resistance-rated construction and opening protectives as required to provide a protected path of egress travel between the exit access and the exit discharge or public way. Exits include exterior exit doors at the level of exit discharge, vertical exit enclosures, exit passageways, horizontal exits, exterior exit stairways, exterior exit ramps and horizontal exits.~~

Reason: The current definition of "EXIT" contains several technical inaccuracies. The definition of exit includes absolute, universal criteria for an exit that describe protection and fire resistance that isn't required on all exit components. Obviously, exterior exit stairways and exterior exit ramps are not interior spaces nor are they necessarily constructed with fire-resistance rated construction and opening protectives. This proposal also acknowledges that some exit components (i.e. an exterior exit door at the level of discharge) may lead directly to the public way. This change simplifies the definition by removing the absolutes and limiting it to describing what part an exit plays in the more general term and application of "means of egress."

The laundry list of "exterior exit doors at the level of exit discharge, vertical exit enclosures, exit passageways, horizontal exits, exterior exit stairways, and exterior exit ramps and horizontal exits" should also be removed, as they are not a definition, but a list of elements that the code includes as part of the "exit." Specific sections elsewhere in the code determine that the "components" are or are not acceptable as exits, such as the allowance for exit access on open stairways in exceptions 3 and 4 in Section 1016.1, which are permitted to be counted as exits from a floor by exceptions in Section 1021.1. This is already a convoluted procedure for determining what is an exit. Additional confusion caused by a list that is not inclusive is only an added burden to understanding exits. This list in the definition is at least incomplete or incorrect since it doesn't include the allowed exceptions. The proposed language will eliminate confusion and misunderstanding of what the code intends.

Cost Impact: The code change proposal will not increase the cost of construction

Public Hearing: Committee:	AS	AM	D
Assembly:	ASF	AMF	DF

ICCFILENAME:Collins-E5-1002.1

E4-09/10

1002.1 (IFC [B] 1002.1)

Proponent: Gregory R. Keith, Professional heuristic Development, representing The Boeing Company

Revise as follows:

1002.1 (IFC [B] 1002.1) Definitions. The following words and terms shall, for the purposes of this chapter and as used elsewhere in this code, have the meanings shown herein.

EXIT. That portion of a means of egress system ~~which is separated from other interior spaces of a building or structure by fire-resistance-rated construction and opening protectives as required to provide a protected path of egress travel between the exit access and the exit discharge or public way. Exits components include exterior exit doors at the level of exit discharge, vertical exit enclosures, exit passageways, horizontal exits, exterior exit stairways, and exterior exit ramps and horizontal exits.~~

Reason: The current definition of "EXIT" contains several technical inaccuracies. It contains some absolute information that is not necessarily applicable to all exit components. Obviously, exterior exit stairways and exterior exit ramps are not interior spaces nor are they necessarily constructed of fire-resistance rated construction and opening protectives. Accordingly, this specific language has been removed from the definition. This proposal also acknowledges that some exit components (i.e. an exterior exit door at the level of discharge) may lead directly to the public way. The term exit "component" was added to the definition of exit so as to be consistent with numerous other means of egress provisions. (Please see the definition of "EXIT ENCLOSURE" and "EXIT PASSAGEWAY.") Additionally, the title of Section 1022 was changed from "vertical exit enclosures" to "exit enclosures" in the 2009 Edition of the IBC. The term "vertical" has been removed from the proposed definition so as to be consistent with current terminology. The definition of "EXIT" is fundamental to proper means of egress system design. It is imperative that it be informative and precise. The proposed language will eliminate confusion and misunderstanding as to what the IBC intends.

Cost Impact: The code change proposal will not increase the cost of construction.

Public Hearing: Committee:	AS	AM	D
Assembly:	ASF	AMF	DF

ICCFILENAME:Keith-E1-1001.1-Exit

E5-09/10

403, 408, 410, 414, 415, 705, 707, 708, 709, 712, 715, 716, 803, 804, [F]909, 1002, 1006, 1007, 1009, 1010, 1015, 1016, 1021, 1022, 1023, 1024, 1025, 1026, 1027, 1028, 1110, 2606, 3007, 3008; (IFC 909, 914.3.1.1, [B]1002, [B]1006, [B]1007, [B]1009, [B]1010, [B]1015, [B]1016, [B]1021, [B]1022, [B]1023, [B]1024, [B]1025, [B]1026, [B]1027, [B]1028, 1803.12.1.2, 2705.4.4); (IMC [F] 513.5)

Proponent: Paul K. Heilstedt, PE, FAIA, Chair, representing ICC Code Technology Committee (CTC)

THIS IS A 2 PART CODE CHANGE. BOTH PARTS WILL BE HEARD BY THE IBC MEANS OF EGRESS COMMITTEE AS 2 SEPARATE CODE CHANGES. SEE THE TENTATIVE HEARING ORDERS FOR THIS COMMITTEE.

PART I – IBC MEANS OF EGRESS

Revise as follows:

SECTION 1002 (IFC [B] 1002) DEFINITIONS

1002.1 (IFC [B] 1002.1) Definitions. The following words and terms shall, for the purposes of this chapter and as used elsewhere in this code, have the meanings shown herein.

EXIT. That portion of a means of egress system ~~which is separated from other interior spaces of a building or structure by fire-resistance-rated construction and opening protectives as required to provide a protected path of egress travel~~ between the exit access and the exit discharge. Exits ~~components~~ include exterior exit doors at the level of exit discharge, ~~vertical exit enclosures~~ interior exit stairways, interior exit ramps, exit passageways, horizontal exits, exterior exit stairways, and exterior exit ramps ~~and horizontal exits~~.

EXIT ACCESS DOORWAY. A door or access point along the path of egress travel from an occupied room, area or space where the path of egress enters an intervening room, corridor, ~~unenclosed~~ exit access stair or ~~unenclosed~~ exit access ramp.

EXIT ACCESS RAMP. An interior ramp that is not a required interior exit ramp.

EXIT ACCESS STAIRWAY. An interior stairway that is not a required interior exit stairway.

EXIT ENCLOSURE. ~~An exit component that is separated from other interior spaces of a building or structure by fire-resistance-rated construction and opening protectives, and provides for a protected path of egress travel in a vertical or horizontal direction to the exit discharge or the public way.~~

INTERIOR EXIT RAMP. An exit component that serves to meet one or more means of egress design requirements, such as required number of exits or exit access travel distance, and provides for a protected path of egress travel to the exit discharge or public way.

INTERIOR EXIT STAIRWAY. An exit component that serves to meet one or more means of egress design requirements, such as required number of exits or exit access travel distance, and provides for a protected path of egress travel to the exit discharge or public way.

SECTION 1009 (IFC [B] 1009) STAIRWAYS

1009.1 (IFC [B] 1009.1) General. Stairways serving occupied portions of a building shall comply with the requirements of this section.

1009.2 (IFC [B] 1009.2) Interior exit stairways. Interior exit stairways shall lead directly to the exterior of the building or shall be extended to the exterior of the building with an exit passageway conforming to the requirements of Section 1023, except as permitted in Section 1027.1.

1009.2.1 (IFC [B] 1009.2.1) Where required. Interior exit stairways shall be included, as necessary, to meet one or more means of egress design requirements, such as required number of exits or exit access travel distance.

1009.2.2 (IFC [B] 1009.2.2) Enclosure. All interior exit stairways shall be enclosed in accordance with the provisions of Section 1022.

1009.3 (IFC [B] 1009.3) Exit access stairways. Floor openings between stories created by exit access stairways shall be enclosed.

Exceptions:

1. In other than Group I-2 and I-3 occupancies, exit access stairways that serve, or atmospherically communicate between, only two stories, are not required to be enclosed.
2. Exit access stairways serving and contained within a single residential dwelling unit or sleeping unit in Group R-1, R-2 or R-3 occupancies are not required to be enclosed.
3. In buildings with only Group B or M occupancies, exit access stairway openings are not required to be enclosed provided that the building is equipped throughout with an automatic sprinkler system in accordance with Section 903.3.1.1, the area of the floor opening between stories does not exceed twice the horizontal projected area of the exit access stairway, and the opening is protected by a draft curtain and closely spaced sprinklers in accordance with NFPA 13.
4. In other than Groups B and M occupancies, exit access stairway openings are not required to be enclosed provided that the building is equipped throughout with an automatic sprinkler system in accordance with Section 903.3.1.1, the floor opening does not connect more than four stories, the area of the floor opening between stories does not exceed twice the horizontal projected area of the exit access stairway, and the opening is protected by a draft curtain and closely spaced sprinklers in accordance with NFPA 13.
5. Exit access stairways within an atrium complying with the provisions of Section 404 are not required to be enclosed.
6. Exit access stairways and ramps in open parking garages that serve only the parking garage are not required to be enclosed.
7. Stairways serving outdoor facilities where all portions of the means of egress are essentially open to the outside are not required to be enclosed.
8. Exit access stairways serving stages complying with Section 410.5.3.1 and 1015.6 are not required to be enclosed.
9. Stairways are permitted to be open between the balcony, gallery or press box and the main assembly floor in occupancies such as theaters, places of religious worship, auditoriums and sports facilities.
10. In Group I-3 occupancies, exit access stairways constructed in accordance with Section 408.5 are not required to be enclosed.

1009.3.1 (IFC [B] 1009.3.1) Construction. Where required, enclosures for exit access stairways shall be constructed in accordance with this section. Exit access stairway enclosures shall be constructed as fire barriers in accordance with Section 707 or horizontal assemblies in accordance with Section 712, or both.

1009.3.1.1 (IFC [B] 1009.3.1.1) Materials. Exit access stairway enclosures shall be of materials permitted by the building type of construction.

1009.3.1.2 (IFC [B] 1009.3.1.2) Fire-resistance rating. Exit access stairway enclosures shall have a fire-resistance rating of not less than 2 hours where connecting four stories or more, and not less than 1 hour where connecting less than four stories. The number of stories connected by the exit access stairway enclosures shall include any basements, but not any mezzanines. Exit access stairway enclosures shall have a fire-resistance rating not less than the floor assembly penetrated, but need not exceed 2 hours.

1009.3.1.3 (IFC [B] 1009.3.1.3) Continuity. Exit access stairway enclosures shall have continuity in accordance with Section 707.5 for fire barriers or Section 712.4 for horizontal assemblies as applicable.

1009.3.1.4 (IFC [B] 1009.3.1.4) Openings. Openings in an exit access stairway enclosure shall be protected in accordance with Section 715 as required for fire barriers. Doors shall be self- or automatic-closing by smoke detection in accordance with Section 715.4.8.3.

1009.3.1.4.1 (IFC [B] 1009.3.1.4.1) Prohibited openings. Openings other than those necessary for the purpose of the exit access stairway enclosure shall not be permitted in exit access stairway enclosures.

1009.3.1.5 (IFC [B] 1009.3.1.5) Penetrations. Penetrations in an exit access stairway enclosure shall be protected in accordance with Section 713 as required for fire barriers.

1009.3.1.5.1 (IFC [B] 1009.3.1.5.1) Prohibited penetrations. Penetrations other than those necessary for the purpose of the exit access stairway enclosure shall not be permitted in exit access stairway enclosures.

1009.3.1.6 (IFC [B] 1009.3.1.6) Joints. Joints in an exit access stairway enclosure shall comply with Section 714.

1009.3.1.7 (IFC [B] 1009.3.1.7) Ducts and air transfer openings. Penetrations of an exit access stairway enclosure by ducts and air transfer openings shall comply with Section 716.

1009.3.1.8 (IFC [B] 1009.3.1.8) Exterior walls. Where exterior walls serve as a part of an exit access stairway enclosure, such walls shall comply with the requirements of Section 705 for exterior walls and the fire-resistance-rated enclosure requirements shall not apply.

1009.4 1009.4 (IFC [B] 1009.4 1009.4) Stairway width. *(No change to text)*

(Renumber subsequent sections)

SECTION 1010 RAMPS

1010.2 (IFC [B] 1010.2) Enclosure. All interior exit ramps shall be enclosed in accordance with the applicable provisions of Section 1022. Exit access ramps shall be enclosed in accordance with the provisions of Section 1009.3 for enclosure of stairways.

(Renumber subsequent sections)

1010.7 1010.8 (IFC [B] 1010.7 1010.8) Ramp construction. All ramps shall be built of materials consistent with the types permitted for the type of construction of the building, except that wood handrails shall be permitted for all types of construction. Ramps used as an exit shall conform to the applicable requirements of Sections 1022.1 through 1022.6 for exit enclosures.

SECTION 1016 (IFC [B] 1016) EXIT ACCESS TRAVEL DISTANCE

1016.1 (IFC [B] 1016.1) General Travel distance limitations. Travel distance within the exit access portion of the means of egress system shall be in accordance with this section. Exits shall be so located on each story such that the maximum length of exit access travel, measured from the most remote point within a story along the natural and unobstructed path of egress travel to an exterior exit door at the level of exit discharge, an entrance to a vertical exit enclosure, an exit passageway, a horizontal exit, an exterior exit stairway or an exterior exit ramp shall not exceed the distances given in Table 1016.1.

Exceptions:

1. Travel distance in open parking garages is permitted to be measured to the closest riser of open exit stairways.
2. In outdoor facilities with open exit access components and open exterior exit stairways or exit ramps, travel distance is permitted to be measured to the closest riser of an exit stairway or the closest slope of the exit ramp.
3. In other than occupancy Groups H and I, the exit access travel distance to a maximum of 50 percent of the exits is permitted to be measured from the most remote point within a building to an exit using unenclosed exit access stairways or ramps when connecting a maximum of two stories. The two connected stories shall be provided with at least two means of egress. Such interconnected stories shall not be open to other stories.
4. In other than occupancy Groups H and I, exit access travel distance is permitted to be measured from the most remote point within a building to an exit using unenclosed exit access stairways or ramps in the first and second stories above grade plane in buildings equipped throughout with an automatic sprinkler system in accordance with Section 903.3.1.1. The first and second stories above grade plane shall be provided with at least two means of egress. Such interconnected stories shall not be open to other stories.

5. ~~Where applicable, travel distance on unenclosed exit access stairways or ramps and on connecting stories shall also be included in the travel distance measurement. The measurement along stairways shall be made on a plane parallel and tangent to the stair tread nosings in the center of the stairway.~~

1016.2 (IFC [B] 1016.2) Limitations. Exit access travel distance shall not exceed the values given in Table 1016.2.

TABLE ~~4016.4~~ 1016.2 (IFC [B] ~~TABLE 4016.4~~ 1016.2)
EXIT ACCESS TRAVEL DISTANCE^a
(Portions of table not shown remain unchanged)

4016.2 1016.2.1 (IFC [B] 4016.2 1016.2.1) Exterior egress balcony increase. Exit access travel distances specified in ~~Section 1016.4 Table 1016.2~~ shall be increased up to an additional 100 feet (30 480 mm) provided the last portion of the exit access leading to the exit occurs on an exterior egress balcony constructed in accordance with Section 1019. The length of such balcony shall not be less than the amount of the increase taken.

1016.3 (IFC [B] 1016.3) Measurement. Exit access travel distance shall be measured from the most remote point within a story along the natural and unobstructed path of horizontal and vertical egress travel to the entrance to an exit.

Exceptions:

1. In open parking garages, exit access travel distance is permitted to be measured to the closest riser of an exit access stairway or the closest slope of an exit access ramp.
2. In outdoor facilities with open exit access components, exit access travel distance is permitted to be measured to the closest riser of an exit access stairway or the closest slope of an exit access ramp.

1016.3.1 (IFC [B] 1016.3.1) Exit access stairways and ramps. Travel distance on exit access stairways or ramps shall be included in the exit access travel distance measurement. The measurement along stairways shall be made on a plane parallel and tangent to the stair tread nosings in the center of the stair and landings. The measurement along ramps shall be made on the walking surface in the center of the ramp and landings.

SECTION 1021(IFC [B] 1021)
NUMBER OF EXITS AND ~~CONTINUITY~~ EXIT CONFIGURATION

1021.1 (IFC [B] 1021.1) General. Each story and occupied roof shall have the minimum number of exits, or access to exits, as specified in this section. The required number of exits, or exit access stairways or ramps providing access to exits, from any story shall be maintained until arrival at grade or a public way. Exits or access to exits from any story shall be configured in accordance with this section. Each story above the second story of a building shall have a minimum of one interior or exterior exit stairway, or interior or exterior exit ramp. At each story above the second story that requires a minimum of three or more exits, or access to exits, a minimum of 50% of the required exits shall be interior or exterior exit stairways, or interior or exterior exit ramps.

Exceptions:

1. Interior exit stairways and interior exit ramps are not required in open parking garages where the means of egress serves only the open parking garage.
2. Interior exit stairways and interior exit ramps are not required in outdoor facilities where all portions of the means of egress are essentially open to the outside.

1021.1 (IFC [B] 1021.1) Exits from stories. All spaces within each story shall have access to the minimum number of approved independent exits as specified in Table 1021.1 based on the occupant load of the story. For the purposes of this chapter, occupied roofs shall be provided with exits as required for stories.

Exceptions:

- ~~1. As modified by Section 403.15 (Additional exit stairway).~~
- ~~2. As modified by Section 1021.2.~~
- ~~3. Exit access stairways and ramps that comply with Exception 3 or 4 of Section 1016.1 shall be permitted to provide the minimum number of approved independent exits required by Table 1021 on each story.~~
- ~~4. In Groups R-2 and R-3 occupancies, one means of egress is permitted within and from individual dwelling units with a maximum occupant load of 20 where the dwelling unit is equipped throughout with an automatic sprinkler system in accordance with Section 903.3.1.1 or 903.3.1.2.~~

5. Within a story, rooms and spaces complying with Section 1015.1 with exits that discharge directly to the exterior at the level of exit discharge, are permitted to have one exit.

The required number of exits from any story shall be maintained until arrival at grade or the public way.

**TABLE 1021.1 (IFC [B] TABLE 1021.1)
MINIMUM NUMBER OF EXITS FOR OCCUPANT LOAD**

OCCUPANT LOAD (persons per story)	MINIMUM NUMBER OF EXITS (per story)
1-500	2
501-1,000	3
More than 1,000	4

1021.1.2 (IFC [B] 1021.1.2) Parking structures. Parking structures shall not have less than two exits from each parking tier, except that only one exit is required where vehicles are mechanically parked. Unenclosed vehicle ramps shall not be considered as required exits unless pedestrian facilities are provided.

1021.1.3 (IFC [B] 1021.1.3) Helistops. The means of egress from helistops shall comply with the provisions of this chapter, provided that landing areas located on buildings or structures shall have two or more exits. For landing platforms or roof areas less than 60 feet (18 288 mm) long, or less than 2,000 square feet (186 m²) in area, the second means of egress is permitted to be a fire escape, alternating tread device or ladder leading to the floor below.

1021.2 (IFC [B] 1021.2) Number of exits Single exits. Only one exit shall be required from Group R-3 occupancy buildings or from stories of other buildings as indicated in Table 1021.2. Occupancies shall be permitted to have a single exit in buildings otherwise required to have more than one exit if the areas served by the single exit do not exceed the limitations of Table 1021.2. Mixed occupancies shall be permitted to be served by single exits provided each individual occupancy complies with the applicable requirements of Table 1021.2 for that occupancy. Where applicable, cumulative occupant loads from adjacent occupancies shall be considered in accordance with the provisions of Section 1004.1. Basements with a single exit shall not be located more than one story below grade plane. Two exits, or exit access stairways or ramps providing access to exits, from any story or occupied roof shall be provided where one of the following conditions exists:

1. The occupant load exceeds one of the values in Table 1021.2.
2. The exit access travel distance exceeds that specified in Table 1021.2 as determined in accordance with the provisions of Section 1016.1.
3. Helistop landing areas located on buildings or structures shall be provided with two exits, or exit access stairways or ramps providing access to exits.

Exceptions:

1. Rooms, areas and spaces complying with Section 1015.1 with exits that discharge directly to the exterior at the level of exit discharge, are permitted to have one exit.
2. Group R-3 occupancy buildings shall be permitted to have a one exit.
3. Parking garages where vehicles are mechanically parked shall be permitted to have one exit.
4. Air traffic control towers shall be provided with the minimum number of exits specified in Section 412.3.
5. Individual dwelling units with a maximum occupant load of 20 in Group R-2 and R-3 occupancies shall be permitted to one exit.
6. Group R-3 and R-4 congregate residences shall be permitted to have one exit.

Where one exit, or exit access stairway or ramp providing access to exits at other stories, is permitted to serve individual stories, mixed occupancies shall be permitted to be served by single exits provided each individual occupancy complies with the applicable requirements of Table 1021.2 for that occupancy. Where applicable, cumulative occupant loads from adjacent occupancies shall be considered in accordance with the provisions of Section 1004.1. Basements with one exit shall not be located more than one story below grade plane.

**TABLE 1021.2 (IFC [B] TABLE 1021.2)
STORIES WITH ONE EXIT OR ACCESS TO ONE EXIT**

STORY	OCCUPANCY	MAXIMUM OCCUPANTS (OR DWELLING UNITS) PER FLOOR STORY	AND MAXIMUM EXIT ACCESS TRAVEL DISTANCE
First story or basement	A, B ^{b,d} , E ^{c,e} , F ^{b,d} , M, U, S ^{b,d}	49 occupants and	75 feet
	H-2, H-3	3 occupants and	25 feet
	H-4, H-5, I, R	10 occupants and	75 feet
	S	29 occupants and	100 feet
Second story	B ^b , F, M, S ^a	29 occupants and	75 feet
	R-2	4 dwelling units and	50 feet
Third story	R-2 ^{a,e}	4 dwelling units and	50 feet
Fourth story and above	NP	NA	NA

For SI: 1 foot = 3048 mm

NP = Not Permitted

NA = Not Applicable

a. For the required number of exits for parking structures, see Section 1021.1.2.

b. For the required number of exits for air traffic control towers, see Section 412.3.

c. Buildings classified as Group R-2 equipped throughout with an automatic sprinkler system in accordance with Section 903.3.1.1 or 903.3.1.2 and provided with emergency escape and rescue openings in accordance with Section 1026.

d. Group B, F and S occupancies in buildings equipped throughout with an automatic sprinkler system in accordance with Section 903.3.1.1 shall have a maximum travel distance of 100 feet.

e. Day care occupancies shall have a maximum occupant load of 10.

1021.2.1 (IFC [B] 1021.2.1) Three or more exits. Three exits, or exit access stairways or ramps providing access to exits at other stories, shall be provided from any story or occupied roof with an occupant load of 501-1,000. Four exits, or exit access stairways or ramps providing access to exits at other stories, shall be provided from any story or occupied roof with an occupant load greater than 1,000.

1021.2.2 (IFC [B] 1021.2.2) Additional exits. In buildings over 420 feet in height, additional exits shall be provided in accordance with Section 403.5.2.

1021.3 (IFC [B] 1021.3) Exit configuration continuity. Exits, or exit access stairways or ramps providing access to exits at other stories, shall be arranged in accordance with the provisions of Section 1015.2 through 1015.2.2. Exits shall be continuous from the point of entry into the exit to the exit discharge.

1021.3.1 (IFC [B] 1021.3.1) Access to exits at adjacent levels. Access to exits at other levels shall be by stairways or ramps. Where access to exits occurs from adjacent building levels, the horizontal and vertical exit access travel distance to the closest exit shall not exceed that specified in Section 1016.1. Access to exits at other levels shall be from an adjacent story.

Exception: Landing platforms or roof areas for helistops that are less than 60 feet (18 288 mm) long, or less than 2,000 square feet (186 m²) in area, shall be permitted to access the second exit by a fire escape, alternating tread device or ladder leading to the story or level below.

1021.4 (IFC [B] 1021.4) Vehicular ramps. Vehicular ramps shall not be considered as an exit access ramp unless pedestrian facilities are provided.

1021.4 (IFC [B] 1021.4) Exit door arrangement. Exit door arrangement shall meet the requirements of Sections 1015.2 through 1015.2.2.

**SECTION 1022 (IFC [B] 1022)
EXIT ENCLOSURES INTERIOR EXIT STAIRWAYS AND RAMPS**

1022.1 (IFC [B] 1022.1) General. Interior exit stairways and interior exit ramps serving as an exit component in a means of egress system shall comply with the requirements of this section. Interior exit stairways and ramps shall lead directly to the exterior of the building or shall be extended to the exterior of the building with an exit passageway conforming to the requirements of Section 1023, except as permitted in Section 1027.1. An interior exit stairway or ramp shall not be used for any purpose other than as a means of egress.

~~1022.1 1022.2 (IFC [B] 1022.1 1022.2) Enclosures required Construction.~~ Enclosures for interior exit stairways and interior exit ramps shall be enclosed with constructed as fire barriers in accordance with Section 707 or horizontal assemblies constructed in accordance with Section 712, or both. Interior exit stairway and ramp Exit enclosures shall have a fire-resistance rating of not less than 2 hours where connecting four stories or more and not less than 1 hour where connecting less than four stories. The number of stories connected by the interior exit stairways or ramps exit enclosure shall include any basements, but not any mezzanines. Interior exit stairways and ramps exit enclosures shall have a fire-resistance rating not less than the floor assembly penetrated, but need not exceed 2 hours. Exit enclosures shall lead directly to the exterior of the building or shall be extended to the exterior of the building with an exit passageway conforming to the requirements of Section 1023, except as permitted in Section 1027.1. An exit enclosure shall not be used for any purpose other than means of egress.

Exceptions-Exception: Interior exit stairways and ramps in Group I-3 occupancies in accordance with the provisions of Section 408.3.8.

1. In all occupancies, other than Groups H and I occupancies, a stairway is not required to be enclosed when the stairway serves an occupant load of less than 10 and the stairway complies with either Item 1.1 or 1.2. In all cases, the maximum number of connecting open stories shall not exceed two.
 - 1.1 The stairway is open to not more than one story above its level of exit discharge;
 - 1.2 The stairway is open to not more than one story below its level of exit discharge.
2. Exits in buildings of Group A-5 where all portions of the means of egress are essentially open to the outside need not be enclosed.
3. Stairways serving and contained within a single residential dwelling unit or sleeping unit in Group R-1, R-2 or R-3 occupancies are not required to be enclosed.
4. Stairways in open parking structures that serve only the parking structure are not required to be enclosed.
5. Stairways in Group I-3 occupancies, as provided for in Section 408.3.8, are not required to be enclosed.
6. Means of egress stairways as required by Sections 410.5.3 and 1015.6.1 are not required to be enclosed.
7. Means of egress stairways from balconies, galleries and press boxes as provided for in Section 1028.5.1, are not required to be enclosed.

~~1022.2 1022.3 (IFC [B] 1022.2 1022.3) Termination.~~ Exit enclosures Interior exit stairways and ramps shall terminate at an exit discharge or a public way.

Exception: An exit enclosures Interior exit stairways and ramps shall be permitted to terminate at an exit passageway complying with Section 1023, provided the exit passageway terminates at an exit discharge or a public way.

~~1022.2.1 1022.3.1 (IFC [B] 1022.2.1 1022.3.1) Extension.~~ Where an exit enclosures interior exit stairways and ramps are is extended to an exit discharge or a public way by an exit passageway, the exit enclosure interior exit stairway and ramp shall be separated from the exit passageway by a fire barrier constructed in accordance with Section 707 or a horizontal assembly constructed in accordance with Section 712, or both. The fire-resistance rating shall be at least equal to that required for the exit enclosure interior exit stairway and ramp. A fire door assembly complying with Section 715.4 shall be installed in the fire barrier to provide a means of egress from the exit enclosure interior exit stairway and ramp to the exit passageway. Openings in the fire barrier other than the fire door assembly are prohibited. Penetrations of the fire barrier are prohibited.

Exception: Penetrations of the fire barrier in accordance with Section 1022.4 shall be permitted.

~~1022.3 1022.4 (IFC [B] 1022.3 1022.4) Openings and penetrations.~~ Exit enclosure Interior exit stairway and ramp opening protectives shall be in accordance with the requirements of Section 715.

Openings in exit enclosures interior exit stairways and ramps other than unprotected exterior openings shall be limited to those necessary for exit access to the enclosure from normally occupied spaces and for egress from the enclosure.

Elevators shall not open into an exit enclosures Interior exit stairways and ramps.

~~1022.4 1022.5 (IFC [B] 1022.4 1022.5) Penetrations.~~ Penetrations into and openings through an exit enclosure Interior exit stairways and ramps are prohibited except for required exit doors, equipment and ductwork necessary for independent ventilation or pressurization, sprinkler piping, standpipes, electrical raceway for fire department communication systems and electrical raceway serving the exit enclosure interior exit stairway and ramp and terminating at a steel box not exceeding 16 square inches (0.010 m²). Such penetrations shall be protected in

accordance with Section 713. There shall be no penetrations or communication openings, whether protected or not, between adjacent ~~exit enclosures~~ interior exit stairways and ramps.

1022.5 1022.6 (IFC [B] 1022.5 1022.6) Ventilation. Equipment and ductwork for ~~exit enclosure~~ interior exit stairway and ramp ventilation as permitted by Section 1022.4 shall comply with one of the following items:

1. Such equipment and ductwork shall be located exterior to the building and shall be directly connected to the ~~exit enclosure~~ interior exit stairway and ramp by ductwork enclosed in construction as required for shafts.
2. Where such equipment and ductwork is located within the ~~exit enclosure~~ interior exit stairway and ramp, the intake air shall be taken directly from the outdoors and the exhaust air shall be discharged directly to the outdoors, or such air shall be conveyed through ducts enclosed in construction as required for shafts.
3. Where located within the building, such equipment and ductwork shall be separated from the remainder of the building, including other mechanical equipment, with construction as required for shafts.

In each case, openings into the fire-resistance-rated construction shall be limited to those needed for maintenance and operation and shall be protected by opening protectives in accordance with Section 715 for shaft enclosures.

The ~~Exit enclosure~~ interior exit stairway and ramp ventilation systems shall be independent of other building ventilation systems.

1022.6 1022.7 (IFC [B] 1022.6 1022.7) Exit enclosure Interior exit stairway and ramp exterior walls. Exterior walls of ~~the an exit enclosure~~ interior exit stairway and ramp shall comply with the requirements of Section 705 for exterior walls. Where nonrated walls or unprotected openings enclose the exterior of the stairway and the walls or openings are exposed by other parts of the building at an angle of less than 180 degrees (3.14 rad), the building exterior walls within 10 feet (3048 mm) horizontally of a nonrated wall or unprotected opening shall have a fire-resistance rating of not less than 1 hour. Openings within such exterior walls shall be protected by opening protectives having a fire protection rating of not less than ¾ hour. This construction shall extend vertically from the ground to a point 10 feet (3048 mm) above the topmost landing of the stairway or to the roof line, whichever is lower.

1022.7 1022.8 (IFC [B] 1022.7 1022.8) Discharge identification. A ~~stairway in an exit enclosure~~ An interior exit stairway and ramp shall not continue below its level of exit discharge unless an approved barrier is provided at the level of exit discharge to prevent persons from unintentionally continuing into levels below. Directional exit signs shall be provided as specified in Section 1011.

1022.8 1022.9 (IFC [B] 1022.8 1022.9) Floor identification signs. A sign shall be provided at each floor landing in ~~exit enclosures~~ an interior exit stairway and ramp connecting more than three stories designating the floor level, the terminus of the top and bottom of the ~~exit enclosure~~ interior exit stairway and ramp and the identification of the stair or ramp. The signage shall also state the story of, and the direction to, the exit discharge and the availability of roof access from the ~~enclosure~~ interior exit stairway and ramp for the fire department. The sign shall be located 5 feet (1524 mm) above the floor landing in a position that is readily visible when the doors are in the open and closed positions. Floor level identification signs in tactile characters complying with ICC A117.1 shall be located at each floor level landing adjacent to the door leading from the ~~enclosure~~ interior exit stairway and ramp into the corridor to identify the floor level.

1022.8.1 1022.9.1 (IFC [B] 1022.8.1 1022.9.1) Signage requirements. Stairway identification signs shall comply with all of the following requirements:

1. The signs shall be a minimum size of 18 inches (457 mm) by 12 inches (305 mm).
2. The letters designating the identification of the ~~stair enclosure~~ interior exit stairway and ramp shall be a minimum of 1 1/2 inches (38 mm) in height.
3. The number designating the floor level shall be a minimum of 5 inches (127 mm) in height and located in the center of the sign.
4. All other lettering and numbers shall be a minimum of 1 inch (25 mm) in height.
5. Characters and their background shall have a nonglare finish. Characters shall contrast with their background, with either light characters on a dark background or dark characters on a light background.
6. When signs required by Section 1022.8 are installed in ~~interior exit enclosures~~ the interior exit stairways and ramps of buildings subject to Section 1024, the signs shall be made of the same materials as required by Section 1024.4.

1022.9 1022.10 (IFC [B] 1022.9 1022.10) Smokeproof enclosures and pressurized stairways and ramps. In buildings required to comply with Section 403 or 405, each of the ~~exit enclosures~~ interior exit stairways and ramps

servicing a story with a floor surface located more than 75 feet (22 860 mm) above the lowest level of fire department vehicle access or more than 30 feet (9144 mm) below the finished floor of a level of exit discharge serving such stories shall be a smokeproof enclosure or pressurized stairway or ramp in accordance with Section 909.20.

SECTION 403 HIGH-RISE BUILDINGS

403.2.3 Structural integrity of interior exit stairways ~~exit enclosures~~ and elevator hoistway enclosures. For high-rise buildings of occupancy category III or IV in accordance with Section 1604.5, and for all buildings that are more than 420 feet (128 000 mm) in building height, enclosures for interior exit stairways ~~exit enclosures~~ and elevator hoistway enclosures shall comply with Sections 403.2.3.1 through 403.2.3.4.

403.2.3.1 Wall assembly. The wall assemblies making up the enclosures for interior exit stairways ~~exit enclosures~~ and elevator hoistway enclosures shall meet or exceed Soft Body Impact Classification Level 2 as measured by the test method described in ASTM C 1629/C 1629M.

403.2.3.2 Wall assembly materials. The face of the wall assemblies making up the enclosures for interior exit stairways ~~exit enclosures~~ and elevator hoistway enclosures that are not exposed to the interior of the enclosures for interior exit stairways ~~exit enclosures~~ or elevator hoistway enclosure shall be constructed in accordance with one of the following methods:

1. The wall assembly shall incorporate not less than two layers of impact-resistant construction board each of which meets or exceeds Hard Body Impact Classification Level 2 as measured by the test method described in ASTM C 1629/C 1629M.
2. The wall assembly shall incorporate not less than one layer of impact-resistant construction material that meets or exceeds Hard Body Impact Classification Level 3 as measured by the test method described in ASTM C 1629/C 1629M.
3. The wall assembly incorporates multiple layers of any material, tested in tandem, that meet or exceed Hard Body Impact Classification Level 3 as measured by the test method described in ASTM C 1629/C 1629M.

403.5.1 Remoteness of interior exit stairways ~~enclosures~~. The Required interior exit stairway ~~stairways~~ ~~enclosures~~ shall be separated by a distance not less than 30 feet (9144 mm) or not less than one-fourth of the length of the maximum overall diagonal dimension of the building or area to be served, whichever is less. The distance shall be measured in a straight line between the nearest points of the ~~exit stairway enclosures~~ interior exit stairways. In buildings with three or more interior exit stairway enclosures, at least two of the interior exit stairway enclosures shall comply with this section. Interlocking or scissor stairs shall be counted as one interior exit stairway.

403.5.4 Smokeproof ~~exit enclosures~~. Every required exit stairway serving floors more than 75 feet (22 860 mm) above the lowest level of fire department vehicle access shall comply with Sections 909.20 and 1022.9.

SECTION 408 GROUP I-3

408.3.8 Interior exit stairway and ramp construction ~~enclosures~~. One of the required interior exit stairway or ramp ~~exit enclosures~~ in each building shall be permitted to have glazing installed in doors and interior walls at each landing level providing access to the ~~enclosure~~ interior exit stairway or ramp, provided that the following conditions are met:

1. The interior exit stairway or ramp ~~exit enclosures~~ shall not serve more than four floor levels.
2. Exit doors shall not be less than 3/4-hour fire door assemblies complying with Section 715.4
3. The total area of glazing at each floor level shall not exceed 5,000 square inches (3m²) and individual panels of glazing shall not exceed 1,296 square inches (0.84 m²).
4. The glazing shall be protected on both sides by an automatic sprinkler system. The sprinkler system shall be designed to wet completely the entire surface of any glazing affected by fire when actuated.
5. The glazing shall be in a gasketed frame and installed in such a manner that the framing system will deflect without breaking (loading) the glass before the sprinkler system operates.
6. Obstructions, such as curtain rods, drapery traverse rods, curtains, drapes or similar materials shall not be installed between the automatic sprinklers and the glazing.

SECTION 410 STAGES AND PLATFORMS

410.5.3.1 Stairway and ramp enclosure. Exit access stairways and ramps serving the stage are not required to be enclosed. Exit access stairways serving the lighting and access catwalks, galleries and gridirons are not required to be enclosed.

SECTION 705 EXTERIOR WALLS

705.2 Projections. Cornices, eave overhangs, exterior balconies and similar projections extending beyond the exterior wall shall conform to the requirements of this section and Section 1406. Exterior egress balconies and exterior exit stairways and ramps shall also comply with Sections 1019 and 1026, respectively. Projections shall not extend beyond the distance determined by the following three methods, whichever results in the lesser projection:

1. A point one-third the distance from the exterior face of the wall to the lot line where protected openings or a combination of protected and unprotected openings are required in the exterior wall.
2. A point one-half the distance from the exterior face of the wall to the lot line where all openings in the exterior wall are permitted to be unprotected or the building is equipped throughout with an automatic sprinkler system installed under the provisions of Section 705.8.2.
3. More than 12 inches (305 mm) into areas where openings are prohibited.

Buildings on the same lot and considered as portions of one building in accordance with Section 705.3 are not required to comply with this section.

SECTION 707 FIRE BARRIERS

707.3.2 Interior exit stairway and ramp construction enclosures. The fire-resistance rating of the fire barrier separating building areas from an interior exit stairway or ramp shall comply with Section 1022.1.

707.3.3 Enclosures for exit access stairways. The fire-resistance rating of the fire barrier separating building areas from an exit access stairway or ramp shall comply with Section 1009.3.1.2.

707.4 Exterior walls. Where exterior walls serve as a part of a required fire-resistance-rated shaft or stairway or ramp exit enclosure, or separation, such walls shall comply with the requirements of Section 705 for exterior walls and the fire-resistance-rated enclosure or separation requirements shall not apply.

Exception: Exterior walls required to be fire-resistance rated in accordance with Section 1019 for exterior egress balconies, Section ~~1022.6~~ 1022.7 for interior exit stairways and ramps enclosures and Section 1026.6 for exterior exit stairways and ramps and stairways.

707.5.1 Supporting construction. The supporting construction for fire barriers shall be protected to afford the required fire-resistance rating of the fire barrier supported. Hollow vertical spaces within a fire barrier shall be fireblocked in accordance with Section 717.2 at every floor level.

Exceptions:

1. The maximum required fire-resistance rating for assemblies supporting fire barriers separating tank storage as provided in Section 415.6.2.1 shall be 2 hours, but not less than required by Table 601 for the building construction type.
2. Shaft enclosures shall be permitted to terminate at a top enclosure complying with Section 707.12.
3. Supporting construction for 1-hour fire barriers required by Table 508.2.5 in buildings of Type IIB, IIIB and VB construction is not required to be fire-resistance rated unless required by other sections of this code.
4. Interior exit stairway and ramp enclosures required by Section 1022.2 and exit access stairway and ramp enclosures required by Section 1009.3 shall be permitted to terminate at a top enclosure complying with Section 707.12.

707.6 Openings. Openings in a fire barrier shall be protected in accordance with Section 715. Openings shall be limited to a maximum aggregate width of 25 percent of the length of the wall, and the maximum area of any single opening shall not exceed 156 square feet (15 m²). Openings in enclosures for exit access stairways and ramps, interior

exit stairways and ramps ~~exit enclosures~~ and exit passageways shall also comply with Sections 1022.3 and 1023.5, respectively.

Exceptions:

1. Openings shall not be limited to 156 square feet (15 m²) where adjoining floor areas are equipped throughout with an automatic sprinkler system in accordance with Section 903.3.1.1.
2. Openings shall not be limited to 156 square feet (15 m²) or an aggregate width of 25 percent of the length of the wall where the opening protective is a fire door serving ~~an enclosure~~ for exit access stairways, exit access ramps, interior exit stairways and interior exit ramps ~~exit enclosures~~.
3. Openings shall not be limited to 156 square feet (15 m²) or an aggregate width of 25 percent of the length of the wall where the opening protective has been tested in accordance with ASTM E 119 or UL263 and has a minimum fire-resistance rating not less than the fire-resistance rating of the wall.
4. Fire window assemblies permitted in atrium separation walls shall not be limited to a maximum aggregate width of 25 percent of the length of the wall.
5. Openings shall not be limited to 156 square feet (15 m²) or an aggregate width of 25 percent of the length of the wall where the opening protective is a fire door assembly in a fire barrier separating an enclosures for exit access stairways, exit access ramps, interior exit stairways and interior exit ramps ~~exit enclosures~~ from an exit passageway in accordance with Section 1022.2.1.

707.7.1 Prohibited penetrations. Penetrations into ~~an enclosure~~ for exit access stairways, exit access ramps, interior exit stairways, interior exit ramps ~~exit enclosures~~ or an exit passageway shall be allowed only when permitted by Section 1009.3.1.5, 4022.4 1022.5 or 1023.6, respectively.

SECTION 708 SHAFT ENCLOSURES

708.1 General. The provisions of this section shall apply to shafts required to protect openings and penetrations through floor/ceiling and roof/ceiling assemblies. Exit access stairways and exit access ramps shall be protected in accordance with the applicable provisions of Section 1009. Interior exit stairways and interior exit ramps shall be protected in accordance with the requirements of Section 1022. ~~Shaft enclosures shall be constructed as fire barriers in accordance with Section 707 or horizontal assemblies in accordance with Section 712, or both.~~

708.2 Shaft enclosure required. Openings through a floor/ceiling assembly shall be protected by a shaft enclosure ~~complying with this section.~~

Exceptions:

1. A shaft enclosure is not required for openings totally within an individual residential dwelling unit and connecting four stories or less.
2. A shaft enclosure is not required in a building equipped throughout with an automatic sprinkler system in accordance with Section 903.3.1.1 for an escalator opening ~~or stairway that is not a portion of the means of egress~~ protected according to Item 2.1 or 2.2.
 - 2.1. Where the area of the floor opening between stories does not exceed twice the horizontal projected area of the escalator ~~or stairway~~ and the opening is protected by a draft curtain and closely spaced sprinklers in accordance with NFPA 13. In other than Groups B and M, this application is limited to openings that do not connect more than four stories.
 - 2.2. Where the opening is protected by approved power-operated automatic shutters at every penetrated floor. The shutters shall be of noncombustible construction and have a fire-resistance rating of not less than 1.5 hours. The shutter shall be so constructed as to close immediately upon the actuation of a smoke detector installed in accordance with Section 907.3 and shall completely shut off the well opening. Escalators shall cease operation when the shutter begins to close. The shutter shall operate at a speed of not more than 30 feet per minute (152.4 mm/s) and shall be equipped with a sensitive leading edge to arrest its progress where in contact with any obstacle, and to continue its progress on release therefrom.
3. A shaft enclosure is not required for penetrations by pipe, tube, conduit, wire, cable and vents protected in accordance with Section 713.4.
4. A shaft enclosure is not required for penetrations by ducts protected in accordance with Section 716.6. Grease ducts shall be protected in accordance with the International Mechanical Code.
5. In other than Group H occupancies, a shaft enclosure is not required for floor openings complying with the provisions for atriums in Section 404.

6. A shaft enclosure is not required for approved masonry chimneys where annular space is fireblocked at each floor level in accordance with Section 717.2.5.
7. In other than Groups I-2 and I-3, a shaft enclosure is not required for a floor opening or an air transfer opening that complies with the following:
 - 7.1. Does not connect more than two stories.
 - ~~7.2. Is not part of the required means of egress system.~~
 - 7.3. Is not concealed within the construction of a wall or a floor/ceiling assembly.
 - 7.4. Is not open to a corridor in Group I and R occupancies.
 - 7.5. Is not open to a corridor on nonsprinklered floors in any occupancy.
 - 7.6. Is separated from floor openings and air transfer openings serving other floors by construction conforming to required shaft enclosures.
 - 7.7. Is limited to the same smoke compartment.
8. A shaft enclosure is not required for automobile ramps in open and enclosed parking garages constructed in accordance with Sections 406.3 and 406.4, respectively.
9. A shaft enclosure is not required for floor openings between a mezzanine and the floor below.
10. A shaft enclosure is not required for joints protected by a fire-resistant joint system in accordance with Section 714.
- ~~11. A shaft enclosure shall not be required for floor openings created by unenclosed stairs or ramps in accordance with Exception 3 or 4 in Section 1016.1.~~
- ~~1142.~~ Floor openings protected by floor fire doors in accordance with Section 712.8.
- ~~13. In Group I-3 occupancies, a shaft enclosure is not required for floor openings in accordance with Section 408.5.~~
- ~~1244.~~ A shaft enclosure is not required for elevator hoistways in open or enclosed parking garages that serve only the parking garage.
- ~~1345.~~ In open or enclosed parking garages a shaft enclosure is not required to enclose mechanical exhaust or supply duct systems when such duct system is contained within and serves only the parking garage.
- ~~1446.~~ Where permitted by other sections of this code.

708.3 Construction. Shaft enclosures shall be constructed as fire barriers in accordance with Section 707 or horizontal assemblies in accordance with Section 712, or both.

708.3 708.4 Materials. (No change to text)

708.4 708.5 Fire-resistance rating. (No change to text)

708.5 708.6 Continuity. (No change to text)

708.6 708.7 Exterior walls. Where exterior walls serve as a part of a required shaft enclosure, such walls shall comply with the requirements of Section 705 for exterior walls and the fire-resistance-rated enclosure requirements shall not apply.

Exception: Exterior walls required to be fire-resistance rated in accordance with Section 1019.2 for exterior egress balconies, Section ~~4022.6~~ 1022.7 for interior exit stairways and ramps ~~exit enclosures~~ and Section 1026.6 for exterior exit stairways and ramps and stairways.

(Renumber subsequent sections)

SECTION 709 FIRE PARTITIONS

709.5 Exterior walls. Where exterior walls serve as a part of a required fire-resistance-rated separation, such walls shall comply with the requirements of Section 705 for exterior walls, and the fire-resistance-rated separation requirements shall not apply.

Exception: Exterior walls required to be fire-resistance rated in accordance with Section 1019.2 for exterior egress balconies, Section 1022.6 for interior exit stairways and ramps ~~exit enclosures~~ and Section 1026.6 for exterior exit stairways and ramps and stairways.

**SECTION 712
HORIZONTAL ASSEMBLIES**

712.4 Continuity. Assemblies shall be continuous without openings, penetrations or joints except as permitted by this section and Sections 708.2, 713.4, 714, ~~1009.3~~ and 1022.1. Skylights and other penetrations through a fire-resistance-rated roof deck or slab are permitted to be unprotected, provided that the structural integrity of the fire-resistance-rated roof assembly is maintained. Unprotected skylights shall not be permitted in roof assemblies required to be fire-resistance rated in accordance with Section 704.10. The supporting construction shall be protected to afford the required fire-resistance rating of the horizontal assembly supported.

Exception: In buildings of Type IIB, IIIB or VB construction, the construction supporting the horizontal assembly is not required to be fire-resistance-rated at the following:

1. Horizontal assemblies at the separations of incidental uses as specified by Table 508.2.5, provided the required fire-resistance rating does not exceed 1 hour.
2. Horizontal assemblies at the separations of dwelling units and sleeping units as required by Section 420.3.
3. Horizontal assemblies at smoke barriers constructed in accordance with Section 710.

**SECTION 715
OPENING PROTECTIVES**

**TABLE 715.4
FIRE DOOR AND FIRE SHUTTER FIRE PROTECTION RATINGS**

TYPE OF ASSEMBLY	REQUIRED ASSEMBLY RATING (hours)	MINIMUM FIRE DOOR AND FIRE SHUTTER ASSEMBLY RATING (hours)
Fire barriers having a required fire-resistance rating of 1 hour: Shaft, exit Enclosures for shafts, exit access stairways, exit access ramps, interior exit stairways, interior exit ramps and exit passageway walls	1	1
Other fire barriers	1	3/4

(Portions of table not shown remain unchanged)

715.4.4 Doors in ~~exit enclosures~~ interior exit stairways and ramps and exit passageways. Fire door assemblies in ~~interior exit stairways and ramps~~ ~~exit enclosures~~ and exit passageways shall have a maximum transmitted temperature end point of not more than 450°F (250°C) above ambient at the end of 30 minutes of standard fire test exposure.

Exception: The maximum transmitted temperature rise is not required in buildings equipped throughout with an automatic sprinkler system installed in accordance with Section 903.3.1.1 or 903.3.1.2.

715.4.6.1 Fire door labeling requirements. Fire doors shall be labeled showing the name of the manufacturer or other identification readily traceable back to the manufacturer, the name or trademark of the third-party inspection agency, the fire protection rating and, where required for fire doors in ~~interior exit stairways and ramps~~ ~~exit enclosures~~ and exit passageways by Section 715.4.4, the maximum transmitted temperature end point. Smoke and draft control doors complying with UL 1784 shall be labeled as such and shall also comply with Section 715.4.6.3. Labels shall be approved and permanently affixed. The label shall be applied at the factory or location where fabrication and assembly are performed.

715.4.7.2 Exit and Elevator, stairway and ramp protectives. Approved fire-protection-rated glazing used in fire door assemblies in elevator, ~~stairways and ramps~~ ~~exit enclosures~~ shall be so located as to furnish clear vision of the passageway or approach to the elevator, ~~ramp or stairway~~ or ramp.

**SECTION 716
DUCT AND TRANSFER OPENINGS**

716.5.2 Fire barriers. Ducts and air transfer openings of fire barriers shall be protected with approved fire dampers installed in accordance with their listing. Ducts and air transfer openings shall not penetrate enclosures for stairways ramps exit enclosures and exit passageways except as permitted by Sections 1022.4 and 1023.6, respectively.

Exception: Fire dampers are not required at penetrations of fire barriers where any of the following apply:

1. Penetrations are tested in accordance with ASTM E119 or UL 263 as part of the fire-resistance-rated assembly.
2. Ducts are used as part of an approved smoke control system in accordance with Section 909 and where the use of a fire damper would interfere with the operation of a smoke control system.
3. Such walls are penetrated by ducted HVAC systems, have a required fire-resistance rating of 1 hour or less, are in areas of other than Group Hand are in buildings equipped throughout with an automatic sprinkler system in accordance with Section 903.3.1.1 or 903.3.1.2. For the purposes of this exception, a ducted HVAC system shall be a duct system for conveying supply, return or exhaust air as part of the structure's HVAC system. Such a duct system shall be constructed of sheet steel not less than No. 26 gage thickness and shall be continuous from the air-handling appliance or equipment to the air outlet and inlet terminals.

**SECTION 803
WALL AND CEILING FINISHES**

**TABLE 803.9
INTERIOR WALL AND CEILING FINISH REQUIREMENTS BY OCCUPANCY^k**

GROUP	SPRINKLERED ^l		NONSPRINKLERED			
		<u>Interior exit stairways, interior exit ramps exit enclosures and exit passageways</u> a, b	<u>Corridors and enclosure for exit access stairways and exit access ramps</u>	Rooms and enclosed spaces ^c	<u>Interior exit stairways, interior exit ramps exit enclosures and exit passageways</u> a, b	<u>Corridors and enclosure for exit access stairways and exit access ramps</u>

(Portions of table not shown remain unchanged)

For SI: 1 inch = 25.4 mm, 1 square foot = 0.0929m².

- a. Class C interior finish materials shall be permitted for wainscotting or paneling of not more than 1,000 square feet of applied surface area in the grade lobby where applied directly to a noncombustible base or over furring strips applied to a noncombustible base and fireblocked as required by Section 803.11.1.
- b. In ~~other than Group I-3 occupancies, exit enclosures of~~ in buildings less than three stories above grade plane of ~~other than Group I-3, Class B interior finish for nonsprinklered buildings and Class C interior finish for sprinklered buildings shall be permitted~~ in interior exit stairways and ramps.
- c. Requirements for rooms and enclosed spaces shall be based upon spaces enclosed by partitions. Where a fire-resistance rating is required for structural elements, the enclosing partitions shall extend from the floor to the ceiling. Partitions that do not comply with this shall be considered enclosing spaces and the rooms or spaces on both sides shall be considered one. In determining the applicable requirements for rooms and enclosed spaces, the specific occupancy thereof shall be the governing factor regardless of the group classification of the building or structure.
- d. Lobby areas in Group A-1, A-2 and A-3 occupancies shall not be less than Class B materials.
- e. Class C interior finish materials shall be permitted in places of assembly with an occupant load of 300 persons or less.
- f. For places of religious worship, wood used for ornamental purposes, trusses, paneling or chancel furnishing shall be permitted.
- g. Class B material is required where the building exceeds two stories.
- h. Class C interior finish materials shall be permitted in administrative spaces.
- i. Class C interior finish materials shall be permitted in rooms with a capacity of four persons or less.
- j. Class B materials shall be permitted as wainscotting extending not more than 48 inches above the finished floor in corridors and exit access stairways and ramps.
- k. Finish materials as provided for in other sections of this code.
- l. Applies when ~~the exit enclosures, exit passageways, corridors or rooms and enclosed spaces are~~ protected by an automatic sprinkler system installed in accordance with Section 903.3.1.1 or 903.3.1.2.

**SECTION 804
INTERIOR FLOOR FINISH**

804.4 Interior floor finish requirements. In all occupancies, interior floor finish and floor covering materials for interior exit stairways and ramps ~~exit enclosures~~, exit passageways, corridors and rooms or spaces not separated from

corridors by full-height partitions extending from the floor to the underside of the ceiling shall withstand a minimum critical radiant flux as specified in Section 804.4.1.

804.4.1 Minimum critical radiant flux. Interior floor finish and floor covering materials in enclosures for stairways and ramp exit enclosures, exit passageways and corridors shall not be less than Class I in Groups I-1, I-2 and I-3 and not less than Class II in Groups A, B, E, H, I-4, M, R-1, R-2 and S. In all areas, floor covering materials shall comply with the DOCFF-1 "pill test" (CPSC 16 CFR, Part 1630).

Exception: Where a building is equipped throughout with an automatic sprinkler system in accordance with Section 903.3.1.1 or 903.3.1.2, Class II materials are permitted in any area where Class I materials are required, and materials complying with the DOC FF-1 "pill test" (CPSC 16 CFR, Part 1630) are permitted in any area where Class II Materials are required.

SECTION 1006 (IFC [B] 1006) MEANS OF EGRESS ILLUMINATION

1006.3 (IFC [B] 1006.3) Illumination emergency power. The power supply for means of egress illumination shall normally be provided by the premises' electrical supply.

In the event of power supply failure, an emergency electrical system shall automatically illuminate all of the following areas:

1. Aisles and unenclosed egress stairways in rooms and spaces that require two or more means of egress.
2. Corridors, interior exit stairways and ramps ~~exit enclosures~~ and exit passageways in buildings required to have two or more exits.
3. Exterior egress components at other than their levels of exit discharge until exit discharge is accomplished for buildings required to have two or more exits.
4. Interior exit discharge elements, as permitted in Section 1027.1, in buildings required to have two or more exits.
5. Exterior landings as required by Section 1008.1.6 for exit discharge doorways in buildings required to have two or more exits.

The emergency power system shall provide power for a duration of not less than 90 minutes and shall consist of storage batteries, unit equipment or an on-site generator. The installation of the emergency power system shall be in accordance with Chapter 27.

SECTION 1007 (IFC [B] 1007) ACCESSIBLE MEANS OF EGRESS

1007.2 (IFC [B] 1007.2) Continuity and components. Each required accessible means of egress shall be continuous to a public way and shall consist of one or more of the following components:

1. Accessible routes complying with Section 1104.
2. Interior exit stairways complying with Sections 1007.3 and 1022.
3. Interior exit access stairways between two stories complying with Sections 1007.3 and 1009.3.
- 3.4 Exterior exit stairways complying with Sections 1007.3 and 1026.
- 4.5. Elevators complying with Section 1007.4.
- 5.6. Platform lifts complying with Section 1007.5.
- 6.7. Horizontal exits complying with Section 1025.
- 7.8. Ramps complying with Section 1010.
- 8.9. Areas of refuge complying with Section 1007.6.

Exceptions:

1. Where the exit discharge is not accessible, an exterior area for assisted rescue shall be provided in accordance with Section 1007.7.
2. Where the exit stairway is open to the exterior, the accessible means of egress shall include either an area of refuge in accordance with Section 1007.6 or an exterior area for assisted rescue in accordance with Section 1007.7.

1007.3 (IFC [B] 1007.3) Stairways. In order to be considered part of an accessible means of egress, ~~an exit access stairway as permitted by Section 1016.1 or exit a stairway between stories~~ shall have a clear width of 48 inches (1219 mm) minimum between handrails and shall either incorporate an area of refuge within an enlarged floor-level landing or shall be accessed from either an area of refuge complying with Section 1007.6 or a horizontal exit. Exit access stairways that connect levels in the same story are not permitted as part an accessible means of egress.

Exceptions:

- ~~1. The area of refuge is not required at open exit access or exit stairways as permitted by Sections 1016.1 and 1022.1 in buildings that are equipped throughout with an automatic sprinkler system installed in accordance with Section 903.3.1.1 or 903.3.1.2.~~
- ~~1.2. The clear width of 48 inches (1219 mm) between handrails is not required at exit access stairways as permitted by Section 1016.1 or exit stairways in buildings equipped throughout with an automatic sprinkler system installed in accordance with Section 903.3.1.1 or 903.3.1.2.~~
- ~~2.3. Areas of refuge are not required at exit stairways in buildings equipped throughout by an automatic sprinkler system installed in accordance with Section 903.3.1.1 or 903.3.1.2.~~
- ~~3.4. The clear width of 48 inches (1219 mm) between handrails is not required for exit stairways accessed from a horizontal exit.~~
- ~~4.5. Areas of refuge are not required at exit stairways serving open parking garages.~~
- ~~5.6. Areas of refuge are not required for smoke protected seating areas complying with Section 1028.6.2.~~
- ~~6.7. The areas of refuge are not required in Group R-2 occupancies.~~

1007.6 (IFC [B] 1007.6) Areas of refuge. Every required area of refuge shall be accessible from the space it serves by an accessible means of egress. The maximum travel distance from any accessible space to an area of refuge shall not exceed the travel distance permitted for the occupancy in accordance with Section 1016.1. Every required area of refuge shall have direct access to a stairway ~~within an exit enclosure~~ complying with Sections 1007.3 and 1022 or an elevator complying with Section 1007.4. Where an elevator lobby is used as an area of refuge, the shaft and lobby shall comply with Section 1022.9 for smokeproof enclosures except where the elevators are in an area of refuge formed by a horizontal exit or smoke barrier.

Exceptions:

- ~~1. A stairway serving an area of refuge is not required to be enclosed where permitted in Sections 1016.1 and 1022.1.~~
- ~~2. A smokeproof enclosure is not required for an elevator lobby used as an area of refuge where the elevator is not required to be enclosed.~~

1007.6.2 (IFC [B] 1007.6.2) Separation. Each area of refuge shall be separated from the remainder of the story by a smoke barrier complying with Section 710 or a horizontal exit complying with Section 1025. Each area of refuge shall be designed to minimize the intrusion of smoke.

Exception: Areas of refuge located within an ~~exit enclosure~~ for exit access stairways or interior exit stairways.

1007.7.2 (IFC [B] 1007.7.2) Exterior exit stairway. Exterior ~~exit~~ stairways that are part of the means of egress for the exterior area for assisted rescue shall provide a clear width of 48 inches (1219 mm) between handrails.

1007.8 (IFC [B] 1007.8) Two-way communication. A two-way communication system shall be provided at the elevator landing on each accessible floor that is one or more stories above or below the story of exit discharge complying with Sections 1007.8.1 and 1007.8.2.

Exceptions:

1. Two-way communication systems are not required at the elevator landing where the two-way communication system is provided within areas of refuge in accordance with Section 1007.6.3.
2. Two-way communication systems are not required on floors provided with ~~exit~~ ramps conforming to the provisions of Section 1010.

**SECTION 1015 (IFC [B] 1015)
EXIT AND EXIT ACCESS DOORWAYS**

1015.2.1 (IFC [B] 1015.2.1) Two exits or exit access doorways. Where two exits or exit access doorways are required from any portion of the exit access, the exit doors or exit access doorways shall be placed a distance apart equal to not less than one-half of the length of the maximum overall diagonal dimension of the building or area to be served measured in a straight line between exit doors or exit access doorways. Interlocking or scissor stairs shall be counted as one ~~exit~~ stairway.

Exceptions:

1. Where ~~exit enclosures~~ interior exit stairways are provided as a portion of the required exit and are interconnected by a 1-hour fire-resistance-rated corridor conforming to the requirements of Section 1018, the required exit separation shall be measured along the shortest direct line of travel within the corridor.
2. Where a building is equipped throughout with an automatic sprinkler system in accordance with Section 903.3.1.1 or 903.3.1.2, the separation distance of the exit doors or exit access doorways shall not be less than one-third of the length of the maximum overall diagonal dimension of the area served.

**SECTION 1023 (IFC [B] 1023)
EXIT PASSAGEWAYS**

1023.3 (IFC [B] 1023.3) Construction. Exit passageway enclosures shall have walls, floors and ceilings of not less than 1-hour fire-resistance rating, and not less than that required for any connecting ~~exit enclosure~~ interior exit stairway or ramp. Exit passageways shall be constructed as fire barriers in accordance with Section 707 or horizontal assemblies constructed in accordance with Section 712, or both.

1023.5 (IFC [B] 1023.5) Openings and penetrations. Exit passageway opening protectives shall be in accordance with the requirements of Section 715.

Except as permitted in Section 402.4.6, openings in exit passageways other than exterior openings shall be limited to those necessary for exit access to the exit passageway from normally occupied spaces and for egress from the exit passageway.

Where an ~~exit enclosure~~ interior exit stairway or ramp is extended to an exit discharge or a public way by an exit passageway, the exit passageway shall also comply with Section 1022.2.1.

Elevators shall not open into an exit passageway.

**SECTION 1024 (IFC [B] 1024)
LUMINOUS EGRESS PATH MARKINGS**

1024.2 (IFC [B] 1024.2) Markings within exit components enclosures. Egress path markings shall be provided in ~~exit enclosures, including vertical exit enclosures~~ interior exit stairways, interior exit ramps and exit passageways, in accordance with Sections 1024.2.1 through 1024.2.6.

1024.2.4 (IFC [B] 1024.2.4) Perimeter demarcation lines. Stair landings and other floor areas within ~~exit enclosures~~ interior exit stairways, interior exit ramps and exit passageways, with the exception of the sides of steps, shall be provided with solid and continuous demarcation lines on the floor or on the walls or a combination of both. The stripes shall be 1 to 2 inches (25mm to 51 mm) wide with interruptions not exceeding 4 inches (102 mm).

Exception: The minimum width of 1 inch (25 mm) shall not apply to outlining stripes listed in accordance with UL 1994.

1024.2.4.1 (IFC [B] 1024.2.4.1) Floor-mounted demarcation lines. Perimeter demarcation lines shall be placed within 4 inches (102 mm) of the wall and shall extend to within 2 inches (51 mm) of the markings on the leading edge of landings. The demarcation lines shall continue across the floor in front of all doors.

Exception: Demarcation lines shall not extend in front of exit discharge doors that lead out of an exit enclosure and through which occupants must travel to complete the exit path.

1024.2.4.2 (IFC [B] 1024.2.4.2) Wall-mounted demarcation lines. Perimeter demarcation lines shall be placed on the wall with the bottom edge of the stripe no more than 4 inches (102 mm) above the finished floor. At the top or bottom of the stairs, demarcation lines shall drop vertically to the floor within 2 inches (51 mm) of the step or landing edge. Demarcation lines on walls shall transition vertically to the floor and then extend across the floor where a line on the floor is the only practical method of outlining the path. Where the wall line is broken by a door, demarcation lines on walls shall continue across the face of the door or transition to the floor and extend across the floor in front of such door.

Exception: Demarcation lines shall not extend in front of exit discharge doors that lead out of an exit ~~enclosure~~ and through which occupants must travel to complete the exit path.

1024.2.6 (IFC [B] 1024.2.6) Doors within the exit path from exit enclosures. Doors through which occupants ~~within an exit enclosure~~ must pass in order to complete the exit path shall be provided with markings complying with Sections 1024.2.6.1 through 1024.2.6.3.

1024.3 (IFC [B] 1024.3) Uniformity. Placement and dimensions of markings shall be consistent and uniform throughout the same ~~exit enclosure~~.

1024.5 (IFC [B] 1024.5) Illumination. ~~Exit enclosures~~ Where photoluminescent exit path markings are installed shall be provided with the minimum means of egress illumination required by Section 1006 for at least 60 minutes prior to periods when the building is occupied.

SECTION 1025 (IFC [B] 1025) HORIZONTAL EXIT

1025.4 (IFC [B] 1025.4) Capacity of refuge area. The refuge area of a horizontal exit shall be a space occupied by the same tenant or a public area and each such refuge area shall be adequate to accommodate the original occupant load of the refuge area plus the occupant load anticipated from the adjoining compartment. The anticipated occupant load from the adjoining compartment shall be based on the capacity of the horizontal exit doors entering the refuge area. The capacity of the refuge area shall be computed based on a net floor area allowance of 3 square feet (0.2787 m²) for each occupant to be accommodated therein.

Exception: The net floor area allowable per occupant shall be as follows for the indicated occupancies:

1. Six square feet (0.6 m²) per occupant for occupancies in Group I-3.
2. Fifteen square feet (1.4 m²) per occupant for ambulatory occupancies in Group I-2.
3. Thirty square feet (2.8 m²) per occupant for nonambulatory occupancies in Group I-2.

The refuge area into which a horizontal exit leads shall be provided with exits adequate to meet the occupant requirements of this chapter, but not including the added occupant load imposed by persons entering it through horizontal exits from other areas. At least one refuge area exit shall lead directly to the exterior or to an interior exit stairway or ramp ~~exit enclosure~~.

Exception: The adjoining compartment shall not be required to have a stairway or door leading directly outside, provided the refuge area into which a horizontal exit leads as stairways or doors leading directly outside and are so arranged that egress shall not require the occupants to return through the compartment from which egress originates.

SECTION 1026 (IFC [B] 1026) ~~EXTERIOR EXIT RAMPS AND STAIRWAYS~~ AND RAMPS

1026.6 (IFC [B] 1026.6) Exterior ~~ramps and stairway~~ and ramp protection. Exterior exit ~~ramps and stairways~~ and ramps shall be separated from the interior of the building as required in Section 1022.1. Openings shall be limited to those necessary for egress from normally occupied spaces.

Exceptions:

1. Separation from the interior of the building is not required for occupancies, other than those in Group R-1 or R-2, in buildings that are no more than two stories above grade plane where a level of exit discharge serving such occupancies is the first story above grade plane.

2. Separation from the interior of the building is not required where the exterior ~~ramp or stairway or ramp~~ is served by an exterior ramp or balcony that connects two remote exterior stairways or other approved exits, with a perimeter that is not less than 50 percent open. To be considered open, the opening shall be a minimum of 50 percent of the height of the enclosing wall, with the top of the openings no less than 7 feet (2134 mm) above the top of the balcony.
3. Separation from the interior of the building is not required for an exterior ~~ramp or stairway or ramp~~ located in a building or structure that is permitted to have unenclosed ~~interior~~ exit access stairways in accordance with Section ~~1009.3~~ 1022.1.
4. Separation from the interior of the building is not required for exterior ~~ramps or stairways or ramps~~ connected to open-ended corridors, provided that Items 4.1 through 4.4 are met:
 - 4.1 The building, including corridors, ~~ramps or stairways or ramps~~, shall be equipped throughout with an automatic sprinkler system in accordance with Section 903.3.1.1 or 903.3.1.2.
 - 4.2 The open-ended corridors comply with Section 1018.
 - 4.3 The open-ended corridors are connected on each end to an exterior exit ~~ramp or stairway or ramp~~ complying with Section 1026.
5. At any location in an open-ended corridor where a change of direction exceeding 45 degrees (0.79 rad) occurs, a clear opening of not less than 35 square feet (3.3 m²) or an exterior ~~ramp or stairway or ramp~~ shall be provided. Where clear openings are provided, they shall be located so as to minimize the accumulation of smoke or toxic gases.

SECTION 1027 (IFC [B] 1027) EXIT DISCHARGE

1027.1 (IFC [B] 1027.1) General. Exits shall discharge directly to the exterior of the building. The exit discharge shall be at grade or shall provide direct access to grade. The exit discharge shall not reenter a building. The combined use of Exceptions 1 and 2 below shall not exceed 50 percent of the number and capacity of the required exits.

Exceptions:

1. A maximum of 50 percent of the number and capacity of ~~the exit enclosures interior exit stairways and ramps~~ is permitted to egress through areas on the level of discharge provided all of the following are met:
 - 1.1 Such ~~exit~~ enclosures egress to a free and unobstructed path of travel to an exterior exit door and such exit is readily visible and identifiable from the point of termination of the ~~exit~~ enclosure.
 - 1.2 The entire area of the level of exit discharge is separated from areas below by construction conforming to the fire-resistance rating for the ~~exit~~ enclosure.
 - 1.3 The egress path from the ~~exit enclosure interior exit stairway and ramp~~ on the level of exit discharge is protected throughout by an approved automatic sprinkler system. All portions of the level of exit discharge with access to the egress path shall either be protected throughout with an automatic sprinkler system installed in accordance with Section 903.3.1.1 or 903.3.1.2, or separated from the egress path in accordance with the requirements for the enclosure of ~~exits interior exit stairways or ramps~~.
2. A maximum of 50 percent of the number and capacity of the ~~exit enclosures for interior exit stairways and ramps~~ is permitted to egress through a vestibule provided all of the following are met:
 - 2.1 The entire area of the vestibule is separated from areas below by construction conforming to the fire-resistance rating for the ~~exit~~ enclosure.
 - 2.2 The depth from the exterior of the building is not greater than 10 feet (3048 mm) and the length is not greater than 30 feet (9144 mm).
 - 2.3 The area is separated from the remainder of the level of exit discharge by construction providing protection at least the equivalent of approved wired glass in steel frames.
 - 2.4 The area is used only for means of egress and exits directly to the outside.
3. ~~Stairways in open parking garages complying with Section 1022.1, Exception 4, are permitted to egress through the open parking garage at their levels of exit discharge.~~
4. Horizontal exits complying with Section 1025 shall not be required to discharge directly to the exterior of the building.

SECTION 1028 (IFC [B] 1028) ASSEMBLY

1028.5.1 (IFC [B] 1028.5.1) Enclosure of openings. ~~Interior stairways and other vertical openings shall be enclosed in an exit enclosure in accordance with Section 1009, as provided in Section 1022.1, except that stairways are permitted to be open between the balcony, gallery or press box and the main assembly floor in occupancies such as~~

~~theaters, places of religious worship, auditoriums and sports facilities. At least one accessible means of egress is required from a balcony, gallery or press box level containing accessible seating locations in accordance with Section 1007.3 or 1007.4.~~

SECTION 1110 SIGNAGE

1110.3 Other signs. Signage indicating special accessibility provisions shall be provided as shown:

1. Each assembly area required to comply with Section 1108.2.7 shall provide a sign notifying patrons of the availability of assistive listening systems.

Exception: Where ticket offices or windows are provided, signs are not required at each assembly area provided that signs are displayed at each ticket office or window informing patrons of the availability of assistive listening systems.

2. At each door to an area of refuge, an exterior area for assisted rescue, an egress stairway, exit passageway and exit discharge, signage shall be provided in accordance with Section 1011.3.
3. At areas of refuge, signage shall be provided in accordance with Section 1007.11.
4. At exterior areas for assisted rescue, signage shall be provided in accordance with Section 1007.11.
5. At two-way communication systems, signage shall be provided in accordance with Section 1007.8.2.
6. Within ~~exit enclosures~~ interior exit stairways and ramps, signage shall be provided in accordance with Section 1022.8.

SECTION 2606 LIGHT-TRANSMITTING PLASTICS

2606.7 Light-diffusing systems. Unless the building is equipped throughout with an automatic sprinkler system in accordance with Section 903.3.1.1, light-diffusing systems shall not be installed in the following occupancies and locations:

1. Group A with an occupant load of 1,000 or more.
2. Theaters with a stage and proscenium opening and an occupant load of 700 or more.
3. Group I-2.
4. Group I-3.
5. ~~Vertical exit enclosures~~ Interior exit stairways and ramps and exit passageways.

SECTION 3007 FIRE SERVICE ACCESS ELEVATOR

3007.4.1 Access. The fire service access elevator lobby shall have direct access to an ~~exit enclosure~~ for an interior exit stairway.

3007.5 Standpipe hose connection. A Class I standpipe hose connection in accordance with Section 905 shall be provided in the ~~exit enclosure~~ interior exit stairway and ramp having direct access from the fire service access elevator lobby.

SECTION 3008 OCCUPANT EVACUATION ELEVATORS

3008.11.1 Access. The occupant evacuation elevator lobby shall have direct access to an ~~exit enclosure~~ interior exit stairway or ramp.

PART II – IFC

SECTION 403 HIGH-RISE BUILDINGS

[F] 403.3.1.1 (IFC 914.3.1.1.1) Riser location. Sprinkler risers shall be placed in interior exit stairways and ramps ~~exit enclosures~~ that are remotely located in accordance with Section 1015.2.

SECTION 414 HAZARDOUS MATERIALS

[F] 414.7.2 (IFC 2705.4.4) Dispensing, use and handling. Where hazardous materials having a hazard ranking of 3 or 4 in accordance with NFPA 704 are transported through corridors ~~or exit enclosures~~, interior exit stairways or ramps or exit passageways there shall be an emergency telephone system, a local manual alarm station or an approved alarm-initiating device at not more than 150-foot (45 720 mm) intervals and at each exit and exit access doorway throughout the transport route. The signal shall be relayed to an approved central, proprietary or remote station service or constantly attended on-site location and shall also initiate a local audible alarm.

SECTION 415 GROUPS H-1, H-2, H-3, H-4 AND H-5

[F] 415.8.4.6.2 (IFC 1803.12.1.2) ~~Exit access~~ Corridors and interior exit stairways and exit ramps enclosures. Emergency alarms for ~~exit access corridors and exit enclosures~~ interior exit stairways and ramps and exit passageways shall comply with Section 414.7.2.

SECTION 909 SMOKE CONTROL SYSTEMS

[F] 909.5 (IFC 909.5, IMC [F] 513.5) Smoke barrier construction. Smoke barriers shall comply with Section 710, and shall be constructed and sealed to limit leakage areas exclusive of protected openings. The maximum allowable leakage area shall be the aggregate area calculated using the following leakage area ratios:

1. Walls: $A/A_w = 0.00100$
2. Interior exit enclosures stairways and ramps and exit passageways: $A/A_w = 0.00035$
3. Enclosed exit access stairways and ramps and all other shafts: $A/A_w = 0.00150$
4. Floors and roofs: $A/A_F = 0.00050$

where:

- A = Total leakage area, square feet (m^2).
A_F = Unit floor or roof area of barrier, square feet (m^2).
A_w = Unit wall area of barrier, square feet (m^2).

The leakage area ratios shown do not include openings due to doors, operable windows or similar gaps. These shall be included in calculating the total leakage area.

Reason: The ICC Board established the ICC Code Technology Committee (CTC) as the venue to discuss contemporary code issues in a committee setting which provides the necessary time and flexibility to allow for full participation and input by any interested party. The code issues are assigned to the CTC by the ICC Board as "areas of study". Information on the CTC, including: meeting agendas; minutes; reports; resource documents; presentations; and all other materials developed in conjunction with the CTC effort can be downloaded from the following website: <http://www.iccsafe.org/cs/cc/ctc/index.html>. Since its inception in April/2005, the CTC has held seventeen meetings - all open to the public.

This proposed change is a result of the CTC's investigation of the area of study entitled "Unenclosed Interior Stairways". The scope of the activity is noted as:

Scope: The current code allows limited use of unenclosed exit stairs. During the previous code development cycles, numerous code changes have been submitted to clarify the intent and application of the code provisions relative to issues such as: exit versus exit access; travel distance measurements; contribution to the minimum number of required exits; etc. Due to the inter-relationship of code provisions, this requires a comprehensive analysis in order to clarify the code requirements.

Objectives:

- A. The Unenclosed Interior Stairway Work Group will answer the following questions based on the current Means of Egress system that is composed of exit, exit access and exit discharge components:
 1. Can an unenclosed interior stairway qualify as an exit?
 2. If an un-enclosed interior stairway can qualify as an exit what is the entrance to the exit (where does the exit begin)?
 3. If an un-enclosed interior stairway can qualify as an exit where does the exit discharge begin (where does the exit end)?
 4. How is travel distance measured when an un-enclosed interior stairway is used as an element in a means of egress?
 5. Does the Minimum Number of Exits Section (1019.1 in the 2006 IBC) require entry to the required exits on each story?
- B. The Unenclosed Interior Stairway Work Group will draft recommend code changes, as determined necessary, to effectively communicate the code requirements based on the answers to the above questions.

(Note that all references to stairs in this reason statement are inclusive of ramps)

Preface: Over that last several code development cycles, there have been numerous proposals intended to address the technical relationships between unenclosed interior stairways, travel distance and the required numbers and location of exits. Through these various proposals, it became evident that there was considerable confusion and disagreement as to what the IBC actually requires or implies. Although some minor changes were approved over time, cumulatively, they did little to resolve the underlying technical question being what part of the three part means of egress system is an unenclosed stair between stories. More specifically: Are stairs that are required to meet means of egress design requirements such as number of exits or exit access travel distance but allowed to be unenclosed an exit or an exit access? Are stairs that are not required for means of egress and supplemental but required to be enclosed do to the number of stories connected required to be protected as a shaft or as an exit enclosure? How should travel distance be measured when unenclosed stairs are part of the path of travel? Can required exits per floor be on an adjacent floor and accessed through an open stair?

At the hearings in Palm Springs the ICC Means of Egress Code Development Committee determined that proper attention could not be provided to the issues in that forum and referred the dilemma to the ICC Code Technology Committee. The CTC agreed that the issue should be researched and assigned a study group to investigate the matter and develop a code change proposal to resolve the issues.

This proposal is based on the following concepts:

All stairs within a building are elements of the means of egress system and must comply with chapter 10

Unenclosed stairways are not exits

All Exit Stairways, to qualify as an exit, must be enclosed with a fire rated enclosure consisting of exit stair shafts and passageways based on current exit enclosure provisions

All stairways that are permitted to be open or are not required stairways for egress purposes are Exit Access Stairways

Exit access stairways must be enclosed with fire rated enclosures based on shaft provisions or may be open in accordance exceptions based on the current exceptions;

Exit access travel distance is measured to an entrance to an exit

Exit access travel distance includes the travel distance on Exit access stairways

Entrances to exits on each story are not mandatory and access to exits on other stories is permissible within certain limitations

The code change in general: All of the current exceptions that will allow for an unenclosed opening to accommodate a stairway in chapter 7 and 10 are being relocated to proposed section 1009.3 including current exceptions to sections 708,1016, and 1022. Section 708 for shaft enclosures is being modified to only address floor openings that do not contain a stairway. All enclosure requirements for stairways, exit or exit access, will originate in section 1009. All fire rated enclosure requirements for exit stairs will remain in chapter 10 and exit access stair enclosure requirements will be placed in proposed section 1009.3 based on current section 708 construction requirements. Ramps will be treated the same as stairways. The new formalized concept of Exit Access Stairway is codified in proposed section 1009.3. New definitions are proposed for Exit Access Stairway(ramp) and Interior Exit Stairway(Ramp).

Specific section change explanations:

Modifications to current section 1002- The definition of Exit is proposed to be modified to remove the fire rated construction provisions from the definition because the construction requirements belong in the code text of section 1022. The definition should be focused on what the exit is, which is simply the component that is between the exit access and the exit discharge. The list of components that qualify as exits has been retained. Additionally "Exit Enclosure" is proposed to be replaced with new terms "Interior Exit Stairway" and "Interior Exit Ramp". This concept is that the exit stairway or ramp in its entirety comprises the exit component, not just the enclosure. New definitions are proposed for Exit Access Ramp and Stairway to support the new concept of their use in proposed section 1009.3. The concept is that all interior stairways and ramps that are not formal exits, whether they are required means of egress components or not, are exit access components.

Modifications to current section 1009-In general, the concept with the changes to 1009 and companion changes to other sections is that 1009 is the point source for all requirements relating to interior stair code requirements including opening protection requirements. Figuratively speaking all stairs lead to section 1009. New sections 1009.1 through 1009.4 have been proposed for addition to current section 1009. 1009.1 establishes that all stairways serving occupied portions of a building must comply with section 1009, whether the stairs are required or not. 1009.2 establishes that exit stairs must lead out of the building directly or through an exit passageway or exit discharge component as is currently required. Section 1009.2.1 establishes the general requirement for when an exit stairway is required. Section 1009.2.2 directs the code user to section 1022 for detailed requirements for construction of the exit stairway including the current enclosure requirements. Proposed section 1009.3 is the new section established to regulate enclosure of exit access stairs. The base line is that all exit access stairs must be enclosed with exceptions to follow. All of the current exceptions in sections 708,1016, and 1022 have been moved to this section, as exceptions to the baseline requirement for enclosure because all open stairs are exit access stairs per this proposal. The exceptions either in text or concept are in 1009.3 with every attempt made to keep them as they are currently applied. New section 1009.3.1 and sub-sections are the construction requirements for enclosure of exit access stairs with the exit access stair would not qualify for one of the exceptions that would allow the stairway to be unenclosed. These requirements have been copied from section 708 Shaft enclosures because current code allows stairways that are not used as exits to meet shaft enclosure requirements of current section 708; current exit enclosure requirements of 1022 are only applicable to required exit stairs.

New section 1010.2-This section is proposed as simply a cross reference for ramps so that they are designed for enclosure no differently than stairways.

Modifications to current section 1016.1-The section is proposed for re-organization based on separation general provisions from specific design provisions. Exceptions 1 and 2 to 1016.1 were moved to proposed section 1016.3 do to conversion of existing section 1016.1 into a general section. Exceptions 3 and 4 to 1016.1 were deleted because the intended use of those exceptions is now captured in proposed modifications to current section 1021.1 and 1021.3.1.

Modifications to current section 1016.1- Exit access added for consistency and the table reference was changed to 1016.2 because this proposal includes changing the table number and reference section.

New section 1016.3- New section 1016.3 is proposed to separate the measurement requirements of exit access travel distance into a stand alone section for better clarity and order.

Modifications to current section 1021.1-Changed the section to a general section. The first sentence proposed replacement is a mix of language clean and addition of the proposed new terms "exit and exit access stairways or ramps". The added second underlined text that proposes to require at least one exit stairway serving each story above the section is the relocation of the concept intended by current exceptions 3 and 4 to 1016.1 that have been proposed for deletion. Exceptions for open parking garages and outdoor facilities were relocated to this section. All of the specific provisions regarding required number of exits were moved from the proposed general section 1021.1 to a new section 1021.2.

Modifications to current section 1021.2-The bulk of this sections changes are to improve the format and flow of the section in keeping with moving specific requirements out of the beginning General section and laying out the requirements for number of exits and configuration in a more logical format. Proposed section 1021.3.1 has a provision that limits the access of exits on another floor to an adjacent level.

Modifications to current section 1022-The section title is proposed to be changed to the new term Interior Exit Stairways and Ramps. Some minor editorial changes have been made to the section and the new terms have been inserted into the text. The deleted last two sentences of 1022.1 (proposed 1022.2) were relocated to proposed section 1009.2.

New Section 410.5.3.1- Based on deletion of current exception #6 to 1022.1 the allowance for open stairs serving stages and support areas has been relocated to chapter 4 under the current stage exit provisions in chapter 4. This is cross referenced in proposed 1009.3 Exception #7.

New exception #3 to Section 706-Added cross-reference to top of shaft enclosure allowance in current section 707.12 to allow use for exit and exit access stair termination. This was done in conjunction with adding exit access stair enclosure requirements, modeled after shaft enclosure requirements, into section 1009.

Modifications to current section 708-Added the sentence in general section 708.1 that removes stair openings from regulation by section 708 and directs the code user to section 1009 for all stair opening protection requirements. As a companion to the intent of that change current exceptions numbers 2 (stair part), 7.2, 11 and 13 that address permissible unenclosed floor openings for stairs have been proposed for deletion and to be moved to section 1009.3: current #2 to proposed 1009.3 Exception #3; current #7.2 and #11 to proposed 1009.3 Exception #1; current #13 to proposed 1009.3 Exception #9. See below for a comparison of the suggested revisions between the Open Stairway study group recommendations and the Vertical Openings committee.

Proposed new section 708.3-Shaft enclosure construction provisions were moved out of the general section in 708.1 and into a new section titled Construction.

Modifications to current section 708.3-In current sections 1002 and 1022 the term "Exit Enclosure" is proposed to be replaced with new terms "Interior Exit Stairway" and "Interior Exit Ramp". This change is companion to that change in term.

Modification to Sections following the main proposal are correlative items to match the proposed revisions to terminology and are not intended to change the scope of the code. Sections that were also reviewed for correlation, but are not proposed to be revised include 403, 408, 410, 414, 415, 705, 707, 708, 709, 712, 715, 716, 803, 804, 909, 1006, 1007, 1015, 1023, 1024, 1025, 1026, 1027, 1028, 1110, 2606, 3007, 3008.

Comparison of CTC proposals for open stairway and vertical openings:

This is a comparison between the overlapping portions of the proposals from the Vertical opening study group and the Open stairway study group. The text in the columns is to compare requirements that may be addressing the same type of provisions. The CTC committee did not feel that there were conflicts in these two proposals, however, in the interest of providing complete information to those participating in the code change process, this matrices should make reviewing for potential conflicts much easier. The first half is the exceptions currently in 708.2 and Section 1022 (exit access stairways). The 2nd half is the construction requirements.

Open Stairway Proposals	Vertical opening Proposals
	Section 708 Section 712
	Shaft Enclosures Vertical Openings
<p><i>For Stairways –</i> 1009.3 Exit access stairways. Floor openings between stories created by exit access stairways shall be enclosed. Exceptions: (See below)</p> <p><i>For Ramps –</i> 1010.2 Enclosure. All interior exit ramps shall be enclosed in accordance with the applicable provisions of Section 1022. Exit access ramps shall be enclosed in accordance with the applicable provisions of Section 1009.3.</p> <p>708.1 General. The provisions of this section shall apply to shafts required to protect openings and penetrations through floor/ceiling and roof/ceiling assemblies. Exit access stairways and ramps shall be protected in accordance with the applicable provisions of Section 1009. Interior exit stairways and ramps shall be protected in accordance with the requirements of Section 1022. Shaft enclosures shall be constructed as fire barriers in accordance with Section 707 or horizontal assemblies in accordance with Section 712, or both.</p>	<p>708.4 712.1 General. The provisions of this section shall apply to the vertical opening applications listed in Sections 712.1.1 through 712.1.18. shafts required to protect openings and penetrations through floor/ceiling and roof/ceiling assemblies. Shaft enclosures shall be constructed as fire barriers in accordance with Section 707 or horizontal assemblies in accordance with Section 712, or both.</p>
	<p>708.2 Shaft enclosure required. Openings through a floor/ceiling assembly shall be protected by a shaft enclosure complying with this Section. Exceptions:</p>
	<p>712.1.1 Smoke compartments. Vertical openings contained entirely within a shaft enclosure complying with Section 709 shall be permitted.</p>
<p>1009.3 - 2. Exit access stairways serving and contained within a single residential dwelling unit or sleeping unit in Group R-1, R-2 or R-3 occupancies are not required to be enclosed.</p>	<p>708.2 - 4, 712.1.2 Individual dwelling unit. A shaft enclosure is not required for Unconcealed vertical openings totally within an individual residential dwelling unit and connecting four stories or less shall be permitted.</p>
<p>708.2 - 2. A shaft enclosure is not required in a building is equipped throughout with an automatic sprinkler system in accordance with Section 903.3.1.1 for an escalator opening or stairway that is not a portion of the means of egress protected according to Item 2.1 or 2.2;</p>	<p>708.2 - 2, 712.1.3 Escalator and Stairway Openings. A shaft enclosure is not required in Where a building is equipped throughout with an automatic sprinkler system in accordance with Section 903.3.1.1 for an escalator opening or stairway that is not a portion of the means of egress shall be protected according to Item 2.1 or 2.2 712.1.3.1 or 712.1.3.2:</p>
<p>708.2 - 2.1. Where the area of the floor opening between stories does not exceed twice the horizontal projected area of the escalator or</p>	<p>708.2 - 2.1, 712.1.3.1 Opening size. Where the area of the floor vertical opening between stories does not exceed twice the horizontal projected</p>

Open Stairway Proposals	Vertical opening Proposals
<p>stairway and the opening is protected by a draft curtain and closely spaced sprinklers in accordance with NFPA 13. In other than Groups B and M, this application is limited to openings that do not connect more than four stories.</p>	<p>area of the escalator or stairway and the opening is protected by a draft curtain and closely spaced sprinklers in accordance with NFPA 13. In other than Groups B and M, this application is limited to openings that do not connect more than four stories.</p>
	<p>708.2-2.2, 712.1.3.2 Automatic shutters. Where the vertical opening is protected by approved power-operated automatic shutters at every penetrated floor. The shutters shall be of noncombustible construction and have a fire-resistance rating of not less than 1.5 hours. The shutter shall be so constructed as to close immediately upon the actuation of a smoke detector installed in accordance with Section 907.11 and shall completely shut off the well opening. Escalators shall cease operation when the shutter begins to close. The shutter shall operate at a speed of not more than 30 feet per minute (152.4 mm/s) and shall be equipped with a sensitive leading edge to arrest its progress where in contact with any obstacle, and to continue its progress on release there from.</p>
	<p>708.2-3, 712.1.4 Penetrations. A shaft enclosure is not required for penetrations by pipe, tube, conduit, wire, cable and vents shall be protected in accordance with Section 713.4-712.4.</p>
	<p>708.2-4, 712.1.5 Ducts. A shaft enclosure is not required for Penetrations by ducts shall be protected in accordance with Section 716.6. Grease ducts shall be protected in accordance with the <i>International Mechanical Code</i>.</p>
<p>1009.3 - 4. Exit access stairways within an atrium complying with the provisions of Section 404 need not be enclosed.</p>	<p>708.2-5, 712.1.6 Atriums. In other than Group H occupancies, a shaft enclosure is not required for floor openings complying with the provisions for atriums in complying with Section 404 shall be permitted.</p>
	<p>708.2-6, 712.1.7 Masonry chimney. A shaft enclosure is not required for approved masonry chimneys shall be permitted where the annular space is fireblocked at each floor level in accordance with Section 717.2.5.</p>
<p>1009.3 - 1. In other than Group I-2 and I-3 occupancies, exit access stairways that serve, or atmospherically communicate between, only two stories, need not be enclosed.</p> <p>708.2 - 7. In other than Groups I-2 and I-3, a shaft enclosure is not required for a floor opening or an air transfer opening that complies with the following:</p> <ul style="list-style-type: none"> 7.1. Does not connect more than two stories. 7.2. Is not part of the required means of egress system. 7.3. Is not concealed within the construction of a wall or a floor/ceiling assembly. 7.4. Is not open to a corridor in Group I and R occupancies. 7.5. Is not open to a corridor on nonsprinklered floors in any occupancy. 7.6. Is separated from floor openings and air transfer openings serving other floors by construction conforming to required shaft enclosures. 7.7. Is limited to the same smoke compartment. 	<p>708.2-7, 712.1.8 Two story openings. In other than Groups I-2 and I-3, a shaft enclosure is not required for a floor opening that is not used as one of the applications listed in this section shall be permitted if it complies with all the items below or an air transfer opening that complies with the following:</p> <ul style="list-style-type: none"> 7-4 1. Does not connect more than two stories. 7-2 2. Does not contain a stairway or ramp required by Chapter 10. Is not part of the required means of egress system. 3 Does not penetrate a horizontal assembly that separates fire areas or smoke barriers that separate smoke compartments. 7-3 4. Is not concealed within the construction of a wall or a floor/ceiling assembly. 7-4 5. Is not open to a corridor in Group I and R occupancies. 7-5 6. Is not open to a corridor on nonsprinklered floors in any occupancy. 7-6 7. Is separated from floor openings and air transfer openings serving other floors by construction conforming to required shaft enclosures. 7-7. Is limited to the same smoke compartment.
<p>1009.3 -5. Exit access stairways and ramps in open parking garages that serve only the parking garage are not required to be enclosed.</p>	<p>708.2-8, 712.1.9 Parking garages. A shaft enclosure is not required for Automobile ramps in open and enclosed parking garages shall be permitted where constructed in accordance with Sections 406.3 and 406.4, respectively.</p>
	<p>708.2-9, 712.1.10 Mezzanine. A shaft enclosure is not required for vertical floor openings between a mezzanine complying with Section 505 and the floor below shall be permitted, and the floor below.</p>
	<p>708.2-10, 712.1.11 Joints. A shaft enclosure is not required for Joints shall be permitted where complying protected by a fire-resistant joint system in accordance with Section 714-715.</p>
<p>1009.2 - 3. In buildings with only group B or M occupancies, exit access stairway openings are not required to be enclosed provided that the building is equipped throughout with an automatic sprinkler system in accordance with Section 903.3.1.1, the area of the floor opening between stories does not exceed twice the horizontal projected area of the exit access stairway, and the opening is protected by a draft curtain and closely spaced sprinklers in accordance with NFPA 13.</p> <p>708.2 - 11. A shaft enclosure shall not be required for floor openings created by unenclosed stairs or ramps in accordance with Exception 3 or 4 in Section 1016.1.</p>	<p>708.2-11, 712.1.12 Unenclosed stairs and ramps. A shaft enclosure shall not be required for vertical floor openings created by unenclosed stairs or ramps in accordance with Exception 3 or 4 in Section 1016.1 shall be permitted.</p>
	<p>708.2-12, 712.1.13 Floor Fire Doors. Floor Vertical openings shall be permitted where protected by floor fire doors in accordance with Section 712.8-711.8.</p>

Open Stairway Proposals	Vertical opening Proposals
<p><u>1009.3 - 9.</u> In Group I-3 occupancies, an exit access enclosure is not required for floor openings in accordance with Section 408.5.</p> <p>708.2 - 13. In Group I-3 occupancies, a shaft enclosure is not required for floor openings in accordance with Section 408.5.</p>	<p>708.2 - 13, 712.1.14. Group I-3. In Group I-3 occupancies, a shaft enclosure is not required for floor vertical openings shall be permitted in accordance with Section 408.5.</p>
	<p>708.2 - 14, 712.1.15 Elevators in parking garages. A shaft enclosure is not required for vertical openings for elevator hoistways in open or enclosed parking garages that serve only the parking garage, and complying with 406.3 and 406.4 respectively, shall be permitted.</p>
	<p>708.2 - 15, 712.1.16 Duct systems in parking garages. Vertical openings for mechanical exhaust or supply duct systems in open or enclosed parking garages a shaft enclosure is not required to enclose mechanical exhaust or supply duct systems complying with 406.3 and 406.4 respectively, shall be permitted to be unenclosed where such duct system is contained within and serves only the parking garage.</p>
	<p>712.1.17 Nonfire-resistance-rated joints. Joints in or between floors without a required fire-resistance rating shall be permitted in accordance with section 711.4.1.</p>
	<p>708.2 - 16, 712.1.18 Openings otherwise permitted. Vertical openings shall be Where permitted where allowed by other sections of this code</p>
<p><u>1009.3 - 6.</u> Stairways serving outdoor facilities where all portions of the means of egress are essentially open to the outside.</p>	
<p><u>1009.3 - 7.</u> Exit access stairways serving stages shall comply with Section 410.5.3.1 and 1015.6.</p>	
<p><u>1009.3 - 8.</u> Exit access stairways serving balconies, galleries and press boxes shall comply with Section 1028.5.1.</p>	
	<p>SECTION 713 SHAFT ENCLOSURES</p>
<p><u>1009.3.1 Construction.</u> Where required, enclosures for exit access stairways shall be constructed in accordance with this section. Exit access stairway enclosures shall be constructed as fire barriers in accordance with Section 707 or horizontal assemblies in accordance with Section 712, or both.</p>	<p>713.1 General. The provisions of this section shall apply to shafts required to protect openings and penetrations through floor/ceiling and roof/ceiling assemblies. Shaft enclosures shall be constructed as fire barriers in accordance with Section 707 or horizontal assemblies in accordance with Section 711, or both.</p>
<p><u>1009.3.1.1 Materials.</u> Exit access stairway enclosures shall be of materials permitted by the building type of construction.</p>	<p>708.3 713.2 Materials. The shaft enclosure shall be of materials permitted by the building type of construction.</p>
<p><u>1009.3.1.2 Fire-resistance rating.</u> Exit access stairway enclosures shall have a fire-resistance rating of not less than 2 hours where connecting four stories or more, and not less than 1 hour where connecting less than four stories. The number of stories connected by the exit access stairway enclosures shall include any basements, but not any mezzanines. Exit access stairway enclosures shall have a fire-resistance rating not less than the floor assembly penetrated, but need not exceed 2 hours.</p>	<p>708.4 713.3 Fire-resistance rating. Shaft enclosures shall have a fire-resistance rating of not less than 2 hours where connecting four stories or more, and not less than 1 hour where connecting less than four stories. The number of stories connected by the shaft enclosure shall include any basements but not any mezzanines. Shaft enclosures shall have a fire-resistance rating not less than the floor assembly penetrated, but need not exceed 2 hours. Shaft enclosures shall meet the requirements of Section 703.2.1.</p>
<p><u>1009.3.1.3 Continuity.</u> Exit access stairway enclosures shall have continuity in accordance with Section 707.5 for fire barriers or Section 712.4 for horizontal assemblies as applicable.</p>	<p>708.5 713.4 Continuity. Shaft enclosures shall be constructed as fire barriers in accordance with Section 707 or horizontal assemblies constructed in accordance with Section 712, or both, and shall have continuity in accordance with Section 707.5 for fire barriers or Section 712.4 for horizontal assemblies as applicable.</p>
<p><u>1009.3.1.8 Exterior walls.</u> Where exterior walls serve as a part of an exit access stairway enclosure, such walls shall comply with the requirements of Section 705 for exterior walls and the fire-resistance-rated enclosure requirements shall not apply.</p> <p>708.6 708.7 Exterior walls. Where exterior walls serve as a part of a required shaft enclosure, such walls shall comply with the requirements of Section 705 for exterior walls and the fire-resistance-rated enclosure requirements shall not apply.</p> <p>Exception: Exterior walls required to be fire-resistance rated in accordance with Section 1019.2 for exterior egress balconies, Section 1022.6 1022.7 for enclosures for interior exit stairways and ramps exit enclosures and Section 1026.6 for exterior exit ramps and stairways.</p>	<p>708.6 713.5 Exterior Walls. Where exterior walls serve as a part of a required shaft enclosure, such walls shall comply with the requirements of Section 705 for exterior walls and the fire-resistance-rated enclosure requirements shall not apply.</p> <p>Exception: Exterior walls required to be fire-resistance rated in accordance with Section 1019.2 for exterior egress balconies, Section 1022.6 for exit enclosures and Section 1026.6 for exterior exit ramps and stairways.</p>
<p><u>1009.3.1.4 Openings.</u> Openings in an exit access stairway enclosure shall be protected in accordance with Section 715 as required for fire</p>	<p>708.7 713.6 Openings. Openings in a shaft enclosure shall be protected in accordance with Section 715 as required for fire barriers. Doors shall be</p>

Open Stairway Proposals	Vertical opening Proposals
barriers. Doors shall be self- or automatic-closing by smoke detection in accordance with Section 715.4.8.3.	self- or automatic closing by smoke detection in accordance with Section 715.4.8.3.
1009.3.1.4.1 Prohibited openings. Openings other than those necessary for the purpose of the exit access stairway enclosure shall not be permitted in exit access stairway enclosures.	708.7.4 713.6.1 Prohibited openings. Openings other than those necessary for the purpose of the shaft shall not be permitted in shaft enclosures.
1009.3.1.5 Penetrations. Penetrations in a shaft enclosure shall be protected in accordance with Section 713 as required for fire barriers.	708.8 713.7 Penetrations. Penetrations in a shaft enclosure shall be protected in accordance with Section 713 as required for <i>fire barriers</i> .
1009.3.1.5.1 Prohibited penetrations. Penetrations other than those necessary for the purpose of the exit access stairway enclosure shall not be permitted in exit access stairway enclosures.	708.8.1 713.7.1 Prohibited penetrations. Penetrations other than those necessary for the purpose of the shaft shall not be permitted in shaft enclosures.
1009.3.1.6 Joints. Joints in an exit access stairway enclosure shall comply with Section 714.	708.9 713.8 Joints. Joints in a shaft enclosure shall comply with Section 714.
1009.3.1.7 Ducts and air transfer openings. Penetrations of an exit access stairway enclosure by ducts and air transfer openings shall comply with Section 716.	708.10 713.9 Duct and air transfer openings. Penetrations of a shaft enclosure by ducts and air transfer openings shall comply with Section 716.
<p>706.5 Continuity. Fire barriers shall extend from the top of the floor/ceiling assembly below to the underside of the floor or roof slab or deck above and shall be securely attached thereto. Such fire barriers shall be continuous through concealed spaces, such as the space above a suspended ceiling. The supporting construction for fire barriers shall be protected to afford the required fire-resistance rating of the fire barrier supported, except for 1-hour fire-resistance-rated incidental use area separations as required by Table 508.2 in buildings of Type IIB, IIIB and VB construction. Hollow vertical spaces within a fire barrier shall be fireblocked in accordance with Section 717.2 at every floor level.</p> <p>Exceptions:</p> <ol style="list-style-type: none"> 1. The maximum required fire-resistance rating for assemblies supporting fire barriers separating tank storage as provided in section 415.6.2.1 shall be 2 hours, but not less than required by Table 601 for the building construction type. 2. Shaft enclosures shall be permitted to terminate at a top enclosure complying with Section 707.12. 3. Interior exit stairway and ramp enclosures required by Section 1009.2.2 and exit access stairway and ramp enclosures required by Section 1009.3 shall be permitted to terminate at a top enclosure complying with Section 707.12. 	<p>708.11 713.10 Enclosure at the bottom. (No change to text)</p> <p>708.12 713.11 Enclosure at top. A shaft enclosure that does not extend to the underside of the roof sheathing, deck or slab of the building shall be enclosed at the top with construction of the same <i>fire-resistance rating</i> as the topmost floor penetrated by the shaft, but not less than the <i>fire-resistance rating</i> required for the shaft enclosure.</p>
	708.13 713.12 Refuse and laundry chutes (No change to text and subsections)
	708.14 713.13 Elevator, dumbwaiter and other hoistways. (No change to text and subsections)

Cost Impact: The code change proposal will increase the cost of construction.

PART I – IBC MEANS OF EGRESS

Public Hearing: Committee: AS AM D
Assembly: ASF AMF DF

PART II – IFC

Public Hearing: Committee: AS AM D
Assembly: ASF AMF DF

ICCFILENAME:Heilsted-G8-410.5.3.1

E6–09/10

505.3, 505.4, 1002.1, 1006.3, 1011.1, 1015 (IFC [B] 1002.1, 1006.3, 1011.1, 1015)

Proponent: Anne VonWeller, Murray City, and Ron Clements, Chesterfield County Building Inspection Department, representing the Utah Chapter of the International Code Council

Revise as follows:

1002.1 (IFC [B] 1002.1) Definitions. The following words and terms shall, for the purposes of this chapter, have the meanings shown herein.

EXIT ACCESS DOORWAY POINT. A door or access point along the path of egress travel within the exit access from an occupied room, area or space where the path of egress enters an intervening room, corridor, unenclosed exit access stair or unenclosed exit access ramp.

SECTION 1015 (IFC [B] 1015.1) EXITS AND EXIT ACCESS DOORWAYS POINTS FOR ROOMS AND SPACES

1015.1 (IFC [B] 1015.1) Number required ~~Exit or exit access doorways from spaces.~~ Two exits or exit access ~~points doorways~~ from any room or space shall be provided where one of the following conditions exists:

Exception: Group I-2 occupancies shall comply with Sections 1014.2.2 through 1014.2.7

1. The occupant load of the room or space exceeds one of the values in Table 1015.1.

Exception: In Groups R-2 and R-3 occupancies, one exit or exit access point means of egress is permitted within and from individual dwelling units with a maximum occupant load of 20 where the dwelling unit is equipped throughout with an automatic sprinkler system in accordance with Section 903.3.1.1 or 903.3.1.2.

2. The common path of egress travel exceeds one of the limitations of Section 1014.3.
3. Where required by Section 1015.3, 1015.4, 1015.5, 1015.6 or 1015.6.1.

Where a building contains mixed occupancies, each individual occupancy shall comply with the applicable requirements for that occupancy. Where applicable, cumulative occupant loads from adjacent occupancies shall be considered in accordance with the provisions of Section 1004.1.

TABLE 1015.1 (IFC [B] 1015.1) ROOMS & SPACES WITH ONE EXIT OR EXIT ACCESS DOORWAYS POINT

(Portions of table not shown remain unchanged)

1015.1.1 (IFC [B] 1015.1.1) Additional ~~Three or more exits or exit access doorways points.~~ Three exits or exit access ~~doorways points~~ shall be provided from any room or space with an occupant load of 501 to 1,000. Four exits or exit access doorways shall be provided from any room or space with an occupant load greater than 1,000.

1015.2 (IFC [B] 1015.2) Availability ~~Exit or exit access doorways arrangement.~~ Required exits and exit access ~~points~~ shall be located in a manner that makes their availability obvious. Exits and exit access points shall be unobstructed at all times. Exit and exit access ~~doorways points~~ shall be arranged in accordance with Sections ~~1015.3, 1015.2.1 and 1015.2.2.~~

~~1015.2.4~~ 1015.3 (IFC [B] ~~1015.2.4~~ 1015.3) Arrangement ~~Two exits or exit access doorways.~~ Where two or more exits or exit access ~~doorways points~~ are required from any portion of the exit access, at least two of the exit doors or exit access doorways points shall be placed a distance apart equal to not less than one-half of the length of the maximum overall diagonal dimension of the building or area to be served measured in a straight line between exit doors or exit access ~~doorways points~~. For doors and doorways such distance shall be measured from the center of doors and openings. For unenclosed interior stairways and ramps such distance shall be measured from the center of the first stair riser or beginning of ramp slope. Interlocking or scissor stairs shall be counted as one exit or exit access point stairway.

Exceptions:

- ~~1.2.~~ Where a building is equipped throughout with an automatic sprinkler system in accordance with Section 903.3.1.1 or 903.3.1.2, the separation distance of the ~~exit doors or exit access doorways~~ shall not be less than one-third of the length of the maximum overall diagonal dimension of the area served.
- ~~2.1.~~ Where exit enclosures are provided as a portion of the required exit and such exit enclosures are interconnected by a 1-hour fire-resistance-rated corridor conforming to the requirements of Section 1018, the required ~~exit~~ separation distance shall be measured along the shortest direct line of egress travel within the corridor.

~~1015.2.2 (IFC [B] 1015.2.2) Three or more exits or exit access doorways.~~ Where access to three or more exits is required, at least two exit doors or exit access doorways shall be arranged in accordance with the provisions of Section 1015.2.1.

~~1015.3 1015.4 (IFC [B] 1015.3 1015.4) Boiler, incinerator and furnace rooms.~~ Two exit access ~~doorways~~ points are required in boiler, incinerator and furnace rooms where the area is over 500 square feet (46 m²) and any fuel-fired equipment exceeds 400,000 British thermal units (Btu) (422 000 KJ) input capacity. Where two exit access ~~doorways~~ points are required, one is permitted to be a fixed ladder or an alternating tread device. Exit access ~~doorways~~ points shall be separated by a horizontal distance equal to one-half the length of the maximum overall diagonal dimension of the room.

~~1015.4 1015.5 (IFC [B] 1015.4 1015.5) Refrigeration machinery rooms.~~ Machinery rooms larger than 1,000 square feet (93 m²) shall have not less than two exits or exit access ~~doorways~~ points. Where two exit access ~~doorways~~ points are required, one such ~~doorways~~ points is permitted to be served by a fixed ladder or an alternating tread device. Exit access ~~doorways~~ points shall be separated by a horizontal distance equal to one-half the maximum horizontal dimension of room.

All portions of machinery rooms shall be within 150 feet (45 720 mm) of an exit or exit access ~~doorways~~ point. An increase in travel distance is permitted in accordance with Section 1016.1.

Doors shall swing in the direction of egress travel, regardless of the occupant load served. Doors shall be tight fitting and self-closing.

~~1015.5 1015.6 (IFC [B] 1015.5 1015.6) Refrigerated rooms or spaces.~~ Rooms or spaces having a floor area larger than 1,000 square feet (93m²), containing a refrigerant evaporator and maintained at a temperature below 68°F (20°C), shall have access to not less than two exits or exit access ~~doorways~~ points.

Travel distance shall be determined as specified in Section 1016.1, but all portions of a refrigerated room or space shall be within 150 feet (45 720 mm) of an exit or exit access ~~doorways~~ points where such rooms are not protected by an approved automatic sprinkler system in accordance with Section 903.3.1.1. Egress is allowed through adjoining refrigerated rooms or spaces.

Exception: Where using refrigerants in quantities limited to the amounts based on the volume set forth in the International Mechanical Code.

~~1015.6 1015.7 (IFC [B] 1015.6 1015.7) Stage means of egress.~~ Where two ~~means of egress~~ exits or exit access points are required, based on the stage size or occupant load, one ~~means of egress~~ exit or exit access point shall be provided on each side of the stage.

~~1015.6.4 1015.7.1 (IFC [B] 1015.6.4 1015.7.1) Gallery, gridiron and catwalk means of egress.~~ The means of egress from lighting and access catwalks, galleries and gridirons shall meet the requirements for occupancies in Group F-2.

Exceptions:

1. A minimum width of 22 inches (559 mm) is permitted for lighting and access catwalks.
2. Spiral stairs are permitted in the means of egress.
3. Stairways required by this subsection need not be enclosed.
4. Stairways with a minimum width of 22 inches (559 mm), ladders, or spiral stairs are permitted in the means of egress.

5. A second ~~means of egress~~ exit or exit access point is not required from these areas where a means of escape to a floor or to a roof is provided. Ladders, alternating tread devices or spiral stairs are permitted in the means of escape.
6. Ladders are permitted in the means of egress.

SECTION 505 MEZZANINES

505.3 Egress. Each occupant of a mezzanine shall have access to at least two independent exits ~~means of egress~~ where the common path of egress travel exceeds the limitations of Section 1014.3. Where an unenclosed stairway provides a means of exit access from a mezzanine, the maximum travel distance includes the distance traveled on the stairway measured in the plane of the tread nosing. Accessible means of egress shall be provided in accordance with Section 1007.

Exception: A single exit or exit access point ~~means of egress~~ shall be permitted in accordance with Section 1015.1.

505.4 Openness. A mezzanine shall be open and unobstructed to the room in which such mezzanine is located except for walls not more than 42 inches (1067 mm) high, columns and posts.

Exceptions:

1. Mezzanines or portions thereof are not required to be open to the room in which the mezzanines are located, provided that the occupant load of the aggregate area of the enclosed space does not exceed 10.
2. A mezzanine having two or more exits or exit access points ~~means of egress~~ is not required to be open to the room in which the mezzanine is located if at least one exit or exit access point ~~of the means of egress~~ provides direct access to an exit from the mezzanine level.
3. Mezzanines or portions thereof are not required to be open to the room in which the mezzanines are located, provided that the aggregate floor area of the enclosed space does not exceed 10 percent of the mezzanine area.
4. In industrial facilities, mezzanines used for control equipment are permitted to be glazed on all sides.
5. In occupancies other than Groups H and I, that are no more than two stories above grade plane and equipped throughout with an automatic sprinkler system in accordance with Section 903.3.1.1, a mezzanine having access to two or more exits ~~means of egress~~ shall not be required to be open to the room in which the mezzanine is located.

SECTION 1006 MEANS OF EGRESS ILLUMINATION

1006.3 (IFC [B] 1006.3) Illumination emergency power. The power supply for means of egress illumination shall normally be provided by the premises' electrical supply.

In the event of power supply failure, an emergency electrical system shall automatically illuminate all of the following areas:

1. Aisles and unenclosed ~~egress~~ exit access stairways and ramps in rooms and spaces that require two or more exits or exit access points. ~~means of egress~~.
2. Corridors, exit enclosures and exit passageways in buildings required to have two or more exits.
3. Exterior egress components at other than their levels of exit discharge until exit discharge is accomplished for buildings required to have two or more exits.
4. Interior exit discharge elements, as permitted in Section 1027.1, in buildings required to have two or more exits.
5. Exterior landings as required by Section 1008.1.6 for exit discharge doorways in buildings required to have two or more exits.

The emergency power system shall provide power for a duration of not less than 90 minutes and shall consist of storage batteries, unit equipment or an on-site generator. The installation of the emergency power system shall be in accordance with Chapter 27.

SECTION 1011 EXIT SIGNS

1011.1 (IFC [B] 1011.1) Where required. Exits and exit access ~~doors~~ points shall be marked by an approved exit sign readily visible from any direction of egress travel. The path of egress travel to exits and within exits shall be marked by readily visible exit signs to clearly indicate the direction of egress travel in cases where the exit or the path of egress travel is not immediately visible to the occupants. Intervening means of egress doors within exits shall be marked by exit signs. Exit sign placement shall be such that no point in an exit access corridor or exit passageway is more than 100 feet (30 480mm) or the listed viewing distance for the sign, which ever is less, from the nearest visible exit sign.

Exception:

1. Exit signs are not required in rooms, spaces or areas which require only one exit or exit access point.
2. Main exterior exit doors or gates that are obviously and clearly identifiable as exits need not have exit signs where approved by the building official.
3. Exit signs are not required in occupancies in Group U and individual sleeping units or dwelling units in Group R-1, R-2 or R-3.
4. Exit signs are not required in dayrooms, sleeping rooms or dormitories in occupancies in Group I-3.
5. In occupancies in Groups A-4 and A-5, exit signs are not required on the seating side of vomitories or openings into seating areas where exit signs are provided in the concourse that are readily apparent from the vomitories. Egress lighting is provided to identify each vomitory or opening within the seating area in an emergency.

Reason:

Background

The 2009 edition added a definition for 'exit access doorway' to clarify that the provisions for exit access doorways applied to components where there is not always a doorway, such as the transition point along the path of egress to unenclosed interior stairways and ramps.

During the discussions of the CTC's Unenclosed Stairway Work Group it was recognized a more clear term was needed to describe the 'point' where requirements such as those for number, availability, and arrangement should be applied. 'Exit Access Point' was very clear and straight forward.

Most of the language in the above proposal was developed in the study group. However, it was determined 'exit access point' was beyond the scope of the specific study. There was a good deal of support for the concept and we were encouraged to bring it forward as a separate change.

The Changes

The one word change in the definition going from 'doorway' to 'point' is the focus of the change. The new term is carried throughout the change. Also, 'within the exit access' was added to make clear an 'exit access point' is only applicable in those portions of the means of egress.

The name of the section was expanded to assist users and avoid confusion with Section 1020.

'Means of egress' was changed to 'exit or exit access point' in several places because means of egress applies to all occupied portions of a building. The change occurs where a term refers to the number of required components which is more appropriate than the general term.

In 1015.3 we have made it clear exactly where to measure the required separation distance between egress components in the exit access. How many debates have been about "Do we measure to the center of the door? The closest edge? The furthest edge? We chose the center. This becomes more important to pin down when now using the concept of 'point'.

Changes to 505, 1006.3, and 1011.1 are for correlation with those in 1015.

Cost Impact: The code change proposal will not increase the cost of construction.

Public Hearing: Committee:	AS	AM	D
Assembly:	ASF	AMF	DF

ICCFILENAME:Vonweller-E3-1023.6

E7-09/10

1002.1 (IFC [B] 1002.1)

Proponent: Edward A Hite, CML, representing self

Revise definition as follows:

1002.1 (IFC [B] 1002.1) Definitions. The following words and terms shall, for the purposes of this chapter and as used elsewhere in the code, have the meanings shown herein:

PANIC HARDWARE. A ~~door-latching bar~~ bar assembly incorporating a device that releases ~~the~~ a lock or latch upon the application of force in the direction of egress travel.

Reason:

1. Latching is only required with fire exit hardware and in areas such as corridors to control smoke.

2. Bars directly releasing locking mechanisms not necessarily attached to the bar, itself, should also be considered panic bars.
3. Currently, panic hardware would need to be a bar in order to meet the requirements of 1008.1.10.1, #3.

Cost Impact: The code change will not increase the cost of construction.

Public Hearing: Committee:	AS	AM	D
Assembly:	ASF	AMF	DF

ICCFILENAME: HITE-E1-1002-PANIC HARDWARE

E8–09/10

1002.1 (IFC [B] 1002.1); IRC R202

Proponent: David W. Cooper, Stair Manufacturing and Design Consultants, representing the Stairway Manufacturers' Association, Inc.

THIS IS A 2 PART CODE CHANGE. PART I WILL BE HEARD BY THE MEANS OF EGRESS COMMITTEE. PART II WILL BE HEARD BY THE IRC BUILDING/ENERGY COMMITTEE. SEE THE TENTATIVE HEARING ORDERS FOR THESE COMMITTEES.

PART I – IBC MEANS OF EGRESS

Add new text as follows:

1002.1 (IFC [B] 1002.1) Definitions. The following words and terms shall, for the purposes of this chapter and as used elsewhere in this code, have the meanings shown herein.

PROJECTED TREAD DEPTH. The full depth dimension of a tread with a nosing projection or the sum of the tread depth measured between adjacent nosings and the depth of the nosing projection.

NOSING PROJECTION. The additional depth of a tread in excess of the tread depth or the distance between the edges of adjacent treads overlapping horizontally.

RISER. The vertical component of a step or stair.

PART II – IRC BUILDING/ENERGY

Revise as follows:

SECTION R202 DEFINITIONS

RISER.

1. The vertical component of a *step or stair*
2. A water pipe that extends vertically one full story or more to convey water to branches or to a group of fixtures

Reason:

Part I -These definitions clarify the intent of the code.

Projected Tread Depth is currently incorrectly characterized as the tread depth in reference to measuring alternating tread devices. This definition will allow for the same terminology to apply to all vertical egress devices as it does to both stairs and ship ladders. Please see our related change to Alternating tread devices.

Nosing projection needs to be better understood by all that use the code. One of the most common misinterpretations akin to the measurement of tread depth is the concept of a nosing projection and how it is measured. This simple definition is long overdue.

Riser is currently listed in the IRC with a definition for a plumbing application. Please see our change to the IRC as well.

Part II-These definitions clarify the intent of the code.

Riser – I the 07/09 cycle the IRC committee pointed out that the term riser was confused with riser height and that further confusion was caused by the present definition of a plumbing application. The stair term is more commonly known and is therefore listed first. The existing definition remains unchanged.

Cost Impact: The code change will not increase the cost of construction.

PART I – IBC MEANS OF EGRESS

Public Hearing: Committee:	AS	AM	D
Assembly:	ASF	AMF	DF

PART II – IRC BUILDING/ENERGY

Public Hearing: Committee: AS AM D
Assembly: ASF AMF DF

ICCFILENAME:Cooper-G1-202

E9–09/10

1003.5 (IFC [B] 1003.5)

Proponent: Homer Maiel, PE, CBO, City of San Jose, representing ICC Tri-Chapter (Peninsula, East Bay, Monterey Bay)

Revise as follows:

1003.5 (IFC [B] 1003.5) Elevation change. Where changes in elevation of less than 12 inches (305 mm) exist in the means of egress, sloped surfaces shall be used. Where the slope is greater than one unit vertical in 20 units horizontal (5-percent slope), ramps complying with Section 1010 shall be used. Where the difference in elevation is 6 inches (152 mm) or less, the ramp shall be equipped with either handrails or floor finish materials that contrast with adjacent floor finish materials.

Exceptions:

1. A single step with a maximum riser height of 7 inches (178 mm) is permitted for buildings with occupancies in Groups F, H, R-2, R-3, S and U at exterior doors not required to be accessible.
2. A stair with a single riser or with two risers and a tread is permitted at locations not required to be accessible by Chapter 11, provided that the risers and treads comply with Section 1009.3, the minimum depth of the tread is 13 inches (330 mm) and at least one handrail complying with Section 1012 is provided within 30 inches (762 mm) of the centerline of the normal path of egress travel on the stair.
3. A step is permitted in aisles serving seating that has a difference in elevation less than 12 inches (305 mm) at locations not required to be accessible by Chapter 11, provided that the risers and treads comply with Section 1025.11 and the aisle is provided with a handrail complying with Section 1025.13.

Throughout a story in a Group I-2 occupancy, any change in elevation in portions of the ~~exit access~~ means of egress that serve nonambulatory persons shall be by means of a ramp or sloped walkway.

Reason: The last paragraph was changed in Palms Springs (E13-07/08). The proponent argued that corridors should not be the only component of MOE mentioned in this section. It was argued that passageways should also be considered. Although the reasoning was sound, "exit access" was added to the Code language. Exit passageways are part of exit component of MOE not exit access. In order to capture all components of MOE, "exit access" is eliminated here and "means of egress" is added.

Cost Impact: The code change proposal will not increase the cost of construction.

Public Hearing: Committee: AS AM D
Assembly: ASF AMF DF

ICCFILENAME:Maiel-E3-1003.5

E10–09/10

1004.1, 1004.1.1, 1004.1.1.1(New), 1004.4, 1004.5, 1004.6, 1005.1, 1005.1.1(New), 1005.1.2(New); [IFC [B] 1004.1, 1004.1.1, 1004.1.1.1(New), 1004.4, 1004.5, 1004.6, 1005.1, 1005.1.1(New), 1005.1.2(New)]

Proponent: Gregory R. Keith, Professional heuristic Development, representing The Boeing Company

Revise as follows:

SECTION 1004 OCCUPANT LOAD

1004.1 (IFC [B] 1004.1) Design occupant load. In determining means of egress requirements, the number of occupants for whom means of egress facilities shall be provided shall be determined in accordance with this section.

Where occupants from accessory areas egress through a primary space, the calculated occupant load for the primary space shall include the total occupant load of the primary space plus the number of occupants egressing through it from the accessory area.

1004.1.1 (IFC [B] 1004.1.1) Cumulative occupant loads. Where the path of egress travel includes intervening rooms, areas or spaces, cumulative occupant loads shall be determined in accordance with this section.

1004.1.1.1 (IFC [B] 1004.1.1.1) Intervening spaces. Where occupants egress from one room, area or space through another, the design occupant load shall be based on the cumulative occupant loads of all rooms, areas or spaces to that point along the path of egress travel.

1004.6 1004.1.1.2 (IFC [B] 1004.6 1004.1.1.2) Mezzanine Adjacent levels. The occupant load of a mezzanine or story level with egress onto through a room, or area or space on an adjacent level below shall be added to that room or area's the occupant load of that room, area or space, and the capacity of the exits shall be designed for the total occupant load thus established.

1004.1.4 1004.1.2 (IFC [B] 1004.1.4 1004.1.2) Areas without fixed seating. (No change to text)

TABLE 1004.1.4 1004.1.2 (IFC [B] 1004.1.4 1004.1.2)
MAXIMUM FLOOR AREA ALLOWANCES PER OCCUPANT
(No change to table)

1004.2 (IFC [B] 1004.2) Increased occupant load. (No change to text)

1004.3 (IFC [B] 1004.3) Posting of occupant load. (No change to text)

1004.4 (IFC [B] 1004.4) Exiting from multiple levels. Where exits serve more than one floor, only the occupant load of each floor considered individually shall be used in computing the required capacity of the exits at that floor, provided that the exit capacity shall not decrease in the direction of egress travel.

1004.5 (IFC [B] 1004.5) Egress convergence. Where means of egress from floors above and below converge at an intermediate level, the capacity of the means of egress from the point of convergence shall not be less than the sum of the two floors.

1004.7 1004.4 (IFC [B] 1004.7 1004.4) Fixed seating. (No change to text)

1004.8 1004.5 (IFC [B] 1004.8 1004.5) Outdoor areas. (No change to text)

1004.9 1004.6 (IFC [B] 1004.9 1004.6) Multiple occupancies. (No change to text)

SECTION 1005
EGRESS WIDTH

1005.1 (IFC [B] 1005.1) Minimum required egress width. The means of egress width shall not be less than required by this section. The total width of means of egress in inches (mm) shall not be less than the total occupant load served by the means of egress multiplied by 0.3 inches (7.62 mm) per occupant for stairways and 0.2 inches (5.08 mm) per occupant for other egress components. The width shall not be less than specified elsewhere in this code. Multiple means of egress shall be sized such that the loss of any one means of egress shall not reduce the available capacity width to less than 50 percent of the required capacity width. The maximum capacity required width from any story of a building shall be maintained to the termination of the means of egress.

Exception: Means of egress complying with Section 1028.

1005.1.1 (IFC [B] 1005.1.1) Egress from multiple levels. Where exits serve more than one story, only the occupant load of each story considered individually shall be used in computing the required width of the exits at that story, provided that the exit width shall not decrease in the direction of egress travel.

1005.1.2 (IFC [B] 1005.1.2) Egress convergence. Where occupants from stories above and below converge at an intermediate level, the width of the exit from the point of convergence shall not be less than that based on the sum of the occupant loads of the two stories.

1005.2 (IFC [B] 1005.2) Door encroachment. (No change to text)

1005.3 (IFC [B] 1005.3) Door hardware encroachment. (No change to text)

Reason: This proposal is intended to repair certain fundamental means of egress provisions relating to the determination of occupant load and egress width. In Section 1004.1, cumulative occupant load provisions have been removed from general topic provisions and placed in a new Section 1004.1.1. In context, provisions for the determination of cumulative occupant loads on the same building level and adjacent building levels are stated in the same section. Adjacent level provisions are based on current Section 1004.6, mezzanine level requirements. It is felt that the scope of the provision needs to be expanded. This is due to the fact that Section 1021.1 permits access to exits from adjacent stories. Cumulative occupant load determination requirements prior to arrival at an exit should be the same regardless of whether the adjacent level is a mezzanine or story.

Sections 1004.4 and 1004.5 have been relocated in context in Section 1005. Each of those sections currently addresses determination of egress capacity, a width related provision. It is felt that it would best serve code users if all width related provisions were located in the same section.

Within Section 1005, the term "capacity" occurs numerous times. The term "capacity" is not defined in the IBC. Moreover, there is no context established for the term. In IBC context, the term capacity is most often confused with the term "width." It is acknowledged that there are capacity based approaches to means of egress design. References to capacity in the IBC, however, do a disservice to code users who do not have benefit of experience with capacity based codes. The IBC needs to stand on its own technical merit and terminology.

Capacity represents the theoretical maximum occupant load that can be accommodated by a minimally sized means of egress component(s). Section 1005.1 clearly states that the required egress width is based on the occupant load served, or the prescribed component minimum, whichever is greater. This is reinforced in the charging statements of virtually every means of egress component section. Obviously, the minimum width of various means of egress components is based on anthropometrics. A 44-inch means of egress component assumes opposing traffic under typical usage conditions. It is acknowledged that it is highly likely that the occupant load served by a pair of 44-inch wide stairways will be less than 294. The theoretical capacity of the stairway is academic. The required width of each stairway is 44 inches. At that point that the occupant load increases beyond 294, the required width increases incrementally and the required width and the capacity now coincidentally align.

When two terms are used to describe the same condition, many code practitioners will attempt to infer differing requirements. This unnecessarily confuses code interpretation and application. In addition to this core correction of differing terminology, it is recommended that the ICC Means of Egress Code Development Committee direct the ICC technical staff to editorially covert these terms elsewhere in the IBC. This will greatly assist in the correct and consistent application of IBC egress width provisions.

Approval of this proposal will add clarity to the IBC by creating consistency in terminology in this fundamental area. Any one us may be familiar with the concept of capacity based means of egress design. Unfortunately, not all code users share in that level of experience. It is imperative that IBC requirements stand alone and assume no prior experience in another code system. After over a decade of publication, the 2012 Edition of the International Building Code should finally correlate this basic terminology and eliminate residual legacy provisions.

Cost Impact: The code change proposal will not increase the cost of construction.

Public Hearing: Committee:	AS	AM	D
Assembly:	ASF	AMF	DF

ICCFILENAME:Keith-E5-1004.1

E11-09/10

1004.1.1 (IFC [B] 1004.1.1)

Proponent: Gregory R. Keith, Professional heuristic Development, representing The Boeing Company

Revise as follows:

1004.1.1 (IFC [B] 1004.1.1) Areas without fixed seating. The number of occupants shall be computed at the rate of one occupant per unit of area as prescribed in Table 1004.1.1. For areas without fixed seating, the occupant load shall not be less than that number determined by dividing the floor area under consideration by the occupant per unit of area factor assigned to the ~~occupancy~~ function of the space as set forth in Table 1004.1.1. Where an intended function use is not listed in Table 1004.1.1, the building official shall establish a function use based on a listed function use that most nearly resembles the intended function use.

Exception: Where approved by the building official, the actual number of occupants for whom each occupied space, floor or building is designed, although less than those determined by calculation, shall be permitted to be used in the determination of the design occupant load.

Reason: The title of the left hand column in Table 1004.1.1 was changed in the 2006 Edition of the IBC from "occupancy" to "function of space." This change was appropriate in that the listed items are functions or uses within an area served by the means of egress system. The stated function may or may not coincide with the occupancy classification of the building. For instance, assembly functions such as conference rooms and break rooms are often contained within Group B (business area) occupancies. Unfortunately, the text that charges Table 1004.1.1 was not included in the approved change to the column title in Table 1004.1.1. This proposal corrects that oversight. Approval of this proposal will create editorial consistency and eliminate potential confusion caused by the differing terms applicable to the same provision.

Cost Impact: The code change proposal will not increase the cost of construction.

Public Hearing: Committee:	AS	AM	D
Assembly:	ASF	AMF	DF

E12-09/10

1004.1.1, Table 1004.1.1 (IFC [B] 1004.1.1, Table 1004.1.1)

Proponent: Gregory R. Keith, Professional heuristic Development, representing The Boeing Company

Revise as follows:

1004.1.1 (IFC [B] 1004.1.1) Areas without fixed seating. The number of occupants shall be computed at the rate of one occupant per unit of area as prescribed in Table 1004.1.1. For areas without fixed seating, the occupant load shall not be less than that number determined by dividing the floor area under consideration by the occupant ~~load per unit of area~~ factor assigned to the occupancy as set forth in Table 1004.1.1. Where an intended use is not listed in Table 1004.1.1, the building official shall establish a use based on a listed use that most nearly resembles the intended use.

Exception: Where approved by the building official, the actual number of occupants for whom each occupied space, floor or building is designed, although less than those determined by calculation, shall be permitted to be used in the determination of the design occupant load.

**TABLE 1004.1.1 (IFC [B] 1004.1.1)
MAXIMUM FLOOR AREA ALLOWANCES PER OCCUPANT**

FUNCTION OF SPACE	OCCUPANT LOAD FACTOR ^a FLOOR AREA IN SQ. FT. PER OCCUPANT
-------------------	---

(Portions of Table not shown, remain unchanged)

For SI: 1 square foot = 0.0929 m².

a. Floor area in sq. ft. per occupant.

Reason: Table 1004.1.1 represents the genesis for the design of a means of egress system. The determination of the occupant load is fundamental to the process. The right hand column represents a factor based on the function of the space that is multiplied by the area under consideration so as to determine the applicable occupant load of the space. The current column title heading, "floor area in sq. ft. per occupant," is somewhat cumbersome and actually states what the unit of measurement represents. The term "occupant load factor" is felt to be easier to use in conversation and more accurately describes the purpose of the tabular values. The term was chosen based on a term that is already recognized in Section 402.4.4.1. The legend in Equation 4-1 states that, "OLF = The occupant load factor (square feet per person). Floor area in sq. ft. per occupant and square feet per person are exactly the same thing. Perhaps a contemporary term such as "occupant density factor" would be more descriptive. Regardless, a functional term should identify this commonly used provision. The descriptive language in the current column title has been appropriately moved to a footnote indicating the unit of measurement. Approval of this proposal will simplify means of egress design by creating a descriptive, common use term while eliminating potential conflicts with other IBC provisions.

Cost Impact: The code change proposal will not increase the cost of construction.

Public Hearing: Committee:	AS	AM	D
Assembly:	ASF	AMF	DF

E13-09/10

Table 1004.1.1 (IFC [B] Table 1004.1.1)

Proponent: Jay Wallace, The Boeing Company

Revise as follows:

**TABLE 1004.1.1 (IFC [B] TABLE 1004.1.1)
MAXIMUM FLOOR AREA ALLOWANCES PER OCCUPANT**

FUNCTION OF SPACE	FLOOR AREA IN SQ. FT. PER OCCUPANT
<u>Aircraft hangars</u>	500 gross
<u>Aircraft Related Uses</u>	
Airport terminal	
Baggage claim	20 gross
Baggage handling	300 gross
Concourse	100 gross
Waiting areas	15 gross
<u>Manufacturing</u>	
<u>Final assembly</u>	500 gross
<u>Sub-assembly fabrication</u>	300 gross
<u>Hangars</u>	
<u>Maintenance and repair</u>	500 gross
<u>Storage or painting</u>	1,000 gross

(Portions of the table not shown remain unchanged.)

Reason: This proposal intends to provide more representative occupant density factors for aircraft manufacturing and storage facilities. Presently, other than for aircraft hangars, there are no industry specific occupant load factors. The recommended values are typical of industry practices. It should be noted that automation has greatly reduced the number of persons necessary to manufacture aircraft. The typically large area necessary for the manufacturing or storage of aircraft is also a factor in the determination of appropriate values. Assigning one occupant for each 32' x 32' area (1000 sf) in an aircraft storage or paint hanger is actually a conservative approach. This figure was selected to account for common usage in smaller facilities. The proposed fabrication occupant load factors also represent typical production practices. These factors become significant in means of egress design. The Boeing Company has a 4,500,000 square foot manufacturing facility. Using the current industrial area occupant load factor of 100 square feet per occupant, the design occupant load of this building is 45,000. It should be noted that The Boeing Company has only 160,000 employees worldwide. In fact, approximately 20,000 employees divided into three shifts work in this factory. The current calculated occupant load would result in a minimum of four exits having 750 feet of egress width. The proposed occupant load factor of 500 would result in a design occupant load of 9,000. Four exits would still be required, however, total egress width would now be a more realistic 150 total feet (50 x 3'-0" doors). Since the facility also contains sub-assembly fabrication operations, the occupant load would be greater than 9,000 resulting in more total egress width. Approval of this proposal will provide code users with occupant load factors representative of industry practices. Such characteristic values will provide for the safe egress of building occupants while not requiring excessive numbers of means of egress components.

Cost Impact: The code change proposal will not increase the cost of construction.

Public Hearing: Committee: AS AM D
 Assembly: ASF AMF DF

ICCFILENAME:Wallace-E1-T1004.1.1

E14-09/10

Table 1004.1.1 (IFC [B] Table 1004.1.1)

Proponent: David S. Collins, FAIA, The Preview Group, Inc. representing The American Institute of Architects

Revise as follows:

**Table 1004.1.1 (IFC [B] Table 1004.1.1)
MAXIMUM FLOOR AREA ALLOWANCES PER OCCUPANT**

FUNCTION OF SPACE	FLOOR AREA IN SQ. FT. PER OCCUPANT
Assembly	
Gaming floors (keno, slots, etc.)	11 gross
Exhibit Gallery and Museum	30 net

(Portions of table not shown remain unchanged.)

Reason: Museums, such as fine arts and sciences, are unique in that determining the occupant load presents considerations that are not usual to calculating loads for other assembly spaces. Such facilities have need for high occupancy rooms, for gala openings etc., and museums have

dedicated spaces for such purposes. It is the actual gallery/exhibit spaces that defy use of the existing tables and it is only those spaces that this change addresses. To determine the occupant load of these spaces one must consider how exhibits are viewed.

What must be taken into consideration is the way exhibit in a museum is viewed. There has never been a museum gallery that has been filled to capacity, using even a 15 sf factor, simply because the display could not be seen by the vast majority of the people in the room at that load. Very few displays are actually viewed from close proximity. In fact, most art works are best viewed from distances and most people are not within 10 to 15 feet of the object being viewed. People do make close inspections but only after viewing the object from a distance and, when approaching a display common courtesy to others in the gallery call for "honoring a person's space" and no one moves toward the object until the other viewer has left the area. Consequently, a museum gallery will never be filled with its design capacity simply because of how the spaces are used.

The King Tut exhibit just left the Dallas Museum of Art and throughout its lengthy stay the galleries were never filled to design capacity. That exhibit included wall-mounted objects and free standing object within the room. The American Institute of Architects is confident that a 30sf/occupant load factor will more than suffice for a safe exiting calculation and we hope to have more data in the near future that will show that an occupant load of 50sf/occupant is satisfactory.

In the City of Cincinnati, Ohio has a number of large museum/assembly facilities that have utilized the factor of 1 occupant per 30 square feet. This includes the Museum Center, the Art Museum and the National Underground Freedom Center. Based on various efforts to rectify the problem with determining occupant loads in this building type, the City of Cincinnati has concluded that the 30 sf/occupant basis is rational and supportable.

In the over 100 year history of the Cincinnati Art Museum there has never been an event that saw the number of occupants that is required by the current code. The 30sf/occupant load factor was derived from calculations of the Museum Center's egress capacity. The structure was designed originally as a train terminal in the 1930's. Using the "smoke protected" concept within the code (because of the volume of the space), the City officials were comfortable with the way the building functioned with a multi-use, high volume traffic occupancy. Therefore, the 30sf factor has been used to design and manage many similar facilities in the Ohio region.

As a part of this change, Section 1004.3 would continue to require posting of occupant loads within an assembly use. The designer and user of the facility would continue to establish the appropriated anticipated occupant load. If the intended use is for other than as a gallery or museum, this should be taken into consideration in the design with an appropriate occupant load for the function.

Cost Impact: The code change proposal will not increase the cost of construction.

Public Hearing: Committee: AS AM D
 Assembly: ASF AMF DF

ICCFILENAME:Collins-E1-T1004.1.1

E15-09/10

Table 1004.1.1 (IFC [B] Table 1004.1.1)

Proponent: Sarah A. Rice, CBO, representing self

Revise as follows:

**TABLE 1004.1.1 (IFC [B] TABLE 1004.1.1)
 MAXIMUM FLOOR AREA ALLOWANCES PER OCCUPANT**

FUNCTION OF SPACE	FLOOR AREA IN SQ. FT. PER OCCUPANT
<u>Circulation space where primary function uses a net value</u> <u>Toilet rooms, stairways, corridors, elevators/escalators</u>	<u>100 gross</u>

(Portions of Table not shown remain unchanged.)

Reason. When the majority of a story is intended to be occupied by a function where the occupant load is calculated using a "net" value, often the circulation or ancillary spaces are ignored. The occupant loads of these spaces often can make the difference between when 2 or 3 exits is required. The issue is NOT when a "gross" value is used to calculate occupant load, but when "net" is used.

The argument has been made that the people who might occupy these spaces are the same people who will be in the rooms adjoining these types of spaces and that they do not contribute an additional occupant load. But think of a college setting where all the rooms in a building are used for classrooms. To calculate the occupant load of the classroom Table 1004.1.1 says to use 20 net. But for anyone who has been in one of these buildings right when classes are changing, there are always students waiting in the hallways for the next class. Do you just ignore the occupant load generated by these people.

The IBC presently does not have any specific provision for non-simultaneous occupancy which is what is being done when these spaces are ignored. Unless people are strictly monitored, there will always be the potential for people to be in all parts of a building at the same time.

Cost Impact: The code change proposal will not increase the cost of construction.

Public Hearing: Committee: AS AM D
 Assembly: ASF AMF DF

ICCFILENAME:Rice-E4-Table 1004.1.1

E16-09/10

Table 1004.1.1 (IFC [B] Table 1004.1.1)

Proponent: Sarah A. Rice, CBO, representing self
Revise as follows:

**TABLE 1004.1.1 (IFC [B] TABLE 1004.1.1)
MAXIMUM FLOOR AREA ALLOWANCES PER OCCUPANT**

FUNCTION OF SPACE	FLOOR AREA IN SQ. FT. PER OCCUPANT
Covered mall building. Open air mall building	See Section 402.4.1

(Portions of Table not shown remain unchanged.)

Reason: Adds a line that directs the user to Chapter 4 when determining the occupant load of a covered mall building.

Cost Impact: The code change proposal will not increase the cost of construction.

Public Hearing: Committee: AS AM D
Assembly: ASF AMF DF

ICCFILENAME:Rice-E6-Table 1004.1.1

E17-09/10 1004.3 (IFC [B] 1004.3)

Proponent: Lee Kranz representing Washington Association of Building Officials (WABO), Technical Code Development Committee

Revise as follows:

1004.3 (IFC [B] 1004.3) Posting of occupant load. Every room or space that is an assembly occupancy shall have the maximum occupant load of the room or space posted in a conspicuous place no more than 12 feet (3.66 m) above the floor, near the main exit or exit access doorway from the room or space. Posted signs shall be of ~~an approved~~ legible permanent design with letters and numbers not less than 1 inch (25 mm) high on a contrasting background and shall be maintained by the owner or authorized agent.

Reason: The term "approved legible design" for a maximum occupant load sign is ambiguous and creates unnecessary conflicts in the field, usually around the time when a certificate of occupancy is ready to be issued. The revised language creates a clear standard that will reduce disagreements and potential waste. The proposed language is similar to the text found in Section 1008.1.9.3.

Cost Impact: The code change will not increase the cost of construction.

Public Hearing: Committee: AS AM D
Assembly: ASF AMF DF

ICCFILENAME: KRANZ-E1-1004.3.DOC

E18-09/10 1004.7 (IFC [B] 1004.7)

Proponent: Ed Roether, Populous (Formerly HOK Sport Venue Event), representing self

Revise as follows:

1004.7 (IFC [B] 1004.7) Fixed seating. For areas having fixed seats and aisles, the occupant load shall be determined by the number of fixed seats installed therein. The occupant load for areas in which fixed seating is not installed, such as waiting spaces ~~and wheelchair spaces~~, shall be determined in accordance with Section 1004.1.1 and added to the number of fixed seats.

The occupant load of wheelchair spaces and the associated companion seat shall be based on one occupant for each wheelchair space and one occupant for the associated companion seat provided in accordance with Section 1108.2.

For areas having fixed seating without dividing arms, the occupant load shall not be less than the number of seats based on one person for each 18 inches (457 mm) of seating length.

The occupant load of seating booths shall be based on one person for each 24 inches (610 mm) of booth seat length measured at the backrest of the seating booth.

Reason: A wheelchair space is required to have a minimum width of 33" and depth of 48" to be in compliance with ICC/ANSI A117.1. However, the minimum space required may be greater depending upon layout with the potential required size of a wheelchair space per ICC/ANSI A117.1 being 36" by 60". In addition, an unobstructed accessible route that is 36" wide is required to adjoin one side of the wheelchair space, so it requires at a minimum 33" by 36" and a maximum of 36" by 60" of additional space for each wheelchair space. Therefore, the minimum amount of space required for one wheelchair space is 19.25 square feet and the maximum amount of space required for one wheelchair space is 30 square feet. Since this wheelchair space is required to be "open" floor space, the floor area per occupant listed in Table 1004.1.1 is 5 square feet per occupant. This means that without this change 1004.7 would require between 4 and 6 occupants within a single wheelchair space and its adjacent accessible route. This is not how it is typically handled or enforced.

In addition, ICC/ANSI A117.1 allows the companion chairs to be movable, therefore the floor space needed for the movable chair would not have fixed seating. At a minimum, a companion chair will be 20" wide, so each companion chair and the respective accessible route for accessing the wheelchair space will take at least 20" by 84" of space, which is 11.67 square feet. This area would equate to at least 2 occupants per companion chair. A wheelchair space location with 8 wheelchair spaces and 8 companion chairs to be in compliance with Section 1108.2.2 would result in an occupant load of 16 per Section 1108.2.2. However, without this change the occupant load for this same space would be between 48 and 64 occupants even though Section 1108.2.2 requires 16. This many occupants would render this wheelchair seating area completely unusable by someone in a wheelchair. This proposal provides consistency between Sections 1004.7, 1108.2 and the approach that has historically been taken to occupant load within a wheelchair seating area.

Cost Impact: This code change proposal will not increase the cost of construction.

Public Hearing: Committee:	AS	AM	D
Assembly:	ASF	AMF	DF

ICCFILENAME:Roether-E2-1004.7

E19-09/10

1004.8 (IFC [B] 1004.8)

Proponent: Eirene Oliphant, MCP, Building Official, representing Leawood, KS

Revise as follows:

1004.8 (IFC [B] 1004.8) Outdoor areas. Yards, patios, courts and similar outdoor areas accessible to and usable by the building occupants shall be provided with means of egress as required by this chapter. The occupant load of such outdoor areas shall be assigned by the building official in accordance with the anticipated use. Where outdoor areas are to be used by persons in addition to the occupants of the building, and the area is confined by barriers, and the path of egress travel from the outdoor areas passes through the building, means of egress requirements for the building shall be provided from the area without passing through the building. ~~based on the sum of the occupant loads of the building plus the outdoor areas.~~

Exceptions:

1. For areas not confined by barriers, the path of egress travel from the outdoor areas are permitted to pass through the building. Means of egress requirements for the building shall be based on the sum of the occupant loads of the building plus the outdoor areas.
2. Outdoor areas used exclusively for service of the building need only have one means of egress.
3. Both outdoor areas associated with Group R-3 and individual dwelling units of Group R-2.

Reason: With the increasing number of outdoor patios associated with restaurants, specifically raised patios requiring guard assemblies, our jurisdiction has concerns with allowing occupants of the patio area re-entering the building in the event of a fire. Why are we sending people into the building where the fire is most likely occurring? If the patio is at grade and not confined by guards, the occupants can very easily escape in the event of a fire. However, if we allow them to pass through the restaurant or force them to jump over a guard, we are increasing the degree of hazard for which they will be exposed. Is not the purpose of the code to safeguard the general welfare of the public? How is allowing the public to enter a building which is on fire providing that?

Cost Impact: The code change will not increase the cost of construction.

Public Hearing: Committee:	AS	AM	D
Assembly:	ASF	AMF	DF

ICCFILENAME:Oliphant-E1-1004.8

E20-09/10

1005.1, Table 1005.1 (New) [IFC [B] 1005.1, Table 1005.1(New)]; 3404.6, 3412.6.11, Table 3412.6.11(1) [IEBC [B] 303.6, 1301.6.11, Table 1301.6.11(1)]; IFC 4604.7, Table 4604.7

Proponent: David S. Collins, FAIA, The Preview Group, Inc., representing The American Institute of Architects

THIS IS A 2 PART CODE CHANGE. BOTH PARTS WILL BE HEARD BY THE MEANS OF EGRESS COMMITTEE AS 2 SEPARATE CODE CHANGES. SEE THE TENTATIVE HEARING ORDER FOR THIS COMMITTEE.

PART I – MEANS OF EGRESS

1. Revise as follows:

1005.1 (IFC [B] 1005.1) Minimum required egress width. The *means of egress* width shall not be less than required by this section Table 1005.1. The total width of *means of egress* in inches (mm) shall not be less than the total *occupant load* served by the *means of egress* multiplied by 0.3 inches (7.62 mm) per occupant for stairways and by 0.2 inches (5.08 mm) per occupant for other egress components. The minimum width shall not be less than specified elsewhere in this code. Multiple *means of egress* shall be sized such that the loss of any one *means of egress* shall not reduce the available capacity to less than 50 percent of the required capacity. The maximum capacity required from any *story* of a building shall be maintained to the termination of the *means of egress*.

Exception: *Means of egress* complying with Section 1028.

2. Add new Table as follows:

TABLE 1005.1 (TABLE [B] 1005.1)
EGRESS WIDTH PER OCCUPANT SERVED

<u>OCCUPANCY</u>	<u>WITHOUT</u> <u>SPRINKLER SYSTEM</u>		<u>WITH</u> <u>SPRINKLER SYSTEM^a</u>	
	<u>Stairways</u> <u>(inches per</u> <u>occupant)</u>	<u>Other egress</u> <u>components</u> <u>(inches per</u> <u>occupant)</u>	<u>Stairways</u> <u>(inches per</u> <u>occupant)</u>	<u>Other egress</u> <u>components</u> <u>(inches per</u> <u>occupant)</u>
Occupancies other than those listed below	0.3	0.2	0.2	0.15
Hazardous: H-1, H-2, H-3 and H-4	0.7	0.4	0.3	0.2
Institutional: I-2	NA	NA	0.3	0.2

For SI: 1 inch = 25.4 mm. NA = Not applicable.

a. Buildings equipped throughout with an automatic sprinkler system in accordance with Section 903.3.1.1 or 903.3.1.2.

3. Delete without substitution:

3404.6 (IEBC [B] 303.6) Means of egress capacity factors. Alterations to any existing building or structure shall not be subject to the egress width factors in Section 1005.1 of the International Building Code for new construction in determining the minimum egress widths or the minimum number of exits in an existing building or structure. The minimum egress widths for the components of the means of egress shall be based on the means of egress width factors in the building code under which the building was constructed, and shall be considered as complying means of egress for any alteration if, in the opinion of the code official, they do not constitute a distinct hazard to life.

4. Revise as follows:

3412.6.11(IEBC [B] 1301.6.11) Means of egress capacity and number. Evaluate the means of egress capacity and the number of exits available to the building occupants. In applying this section, the means of egress are required to conform to the following sections of this code: 1003.7, 1004, 1005.1, 1014.2, 1014.3, 1015.2, 1021, 1024.1, 1027.2, 1027.6, 1028.2, 1028.3, 1028.4 and 1029 [except that the minimum width required by this section shall be determined solely by the width for the required capacity in accordance with Table 3412.6.11(1)]. The number of exits credited is the number that is available to each occupant of the area being evaluated. Existing fire escapes shall be accepted as a component in the means of egress when conforming to Section 3406.

Under the categories and occupancies in Table 3412.6.11(2), determine the appropriate value and enter that value into Table 3412.7 under Safety Parameter 3412.6.11, Means of Egress Capacity, for means of egress and general safety.

5. Delete without substitution:

**TABLE 3412.6.11(1) (IEBC [B] 1301.6.11(1))
EGRESS WIDTH PER OCCUPANT SERVED**

OCCUPANCY	WITHOUT SPRINKLER SYSTEM		WITH SPRINKLER SYSTEM ^a	
	Stairways (inches per occupant)	Other egress components (inches per occupant)	Stairways (inches per occupant)	Other egress components (inches per occupant)
Occupancies other than those listed below	0.3	0.2	0.2	0.15
Hazardous: H-1, H-2, H-3 and H-4	0.7	0.4	0.3	0.2
Institutional: I-2	NA	NA	0.3	0.2

For SI: 1 inch = 25.4 mm. NA = Not applicable.

a. Buildings equipped throughout with an automatic sprinkler system in accordance with Section 903.3.1.1 or 903.3.1.2.

6. Revise as follows:

**TABLE 3412.6.11(2) (IEBC [B] TABLE 1301.6.11(2))
MEANS OF EGRESS VALUES
(No change to table)**

PART II – IFC

Delete without substitution:

4604.7 Minimum required egress width. The means of egress width shall not be less than as required by the code under which constructed but not less than as required by this section. The total width of means of egress in inches (mm) shall not be less than the total occupant load served by the means of egress multiplied by the factors in Table 4604.7 and not less than specified elsewhere in this section. Multiple means of egress shall be sized such that the loss of any one means of egress shall not reduce the available capacity to less than 50 percent of the required capacity. The maximum capacity required from any story of a building shall be maintained to the termination of the means of egress.

**TABLE 4604.7
EGRESS WIDTH PER OCCUPANT SERVED**

OCCUPANCY	WITHOUT SPRINKLER SYSTEM		WITH SPRINKLER SYSTEM ^a	
	Stairways (inches per occupant)	Other egress components (inches per occupant)	Stairways (inches per occupant)	Other egress components (inches per occupant)
Occupancies other than those listed below	0.3	0.2	0.2	0.15
Hazardous: H-1, H-2, H-3 and H-4	0.7	0.4	0.3	0.2
Institutional: I-2	NA	NA	0.3	0.2

For SI: 1 inch = 25.4 mm. NA = Not applicable.

a. Buildings equipped throughout with an automatic sprinkler system in accordance with Section 903.3.1.1 or 903.3.1.2.

(Renumber subsequent sections)

Reason: This change will undo what happened as a result of code change E19-07/08. The major issue was the elimination of the added capacity in buildings when they are protected by a sprinkler system. The proponents indicated that they felt that circumstances arise where the evacuation of a building may be necessary in circumstances where there is no threat of a fire.

While this undoubtedly is true, there is no record, nor were any offered as part of the supporting information for this change for any event or series of events causing a loss of life due to this modification to the fundamental capacity of each element of the means of egress. On the contrary, the record of life loss in buildings which are protected by fire suppression is remarkable.

Events such as earthquakes, and tornados and even terrorist attacks are not events that can be planned for. Hurricanes and floods are typically fairly well understood and can be planned for allowing persons to leave in an orderly fashion. However, these events pose little immediate threat to building occupants. Even though the WTC was attacked by airplanes, the NIST report states:

*During the last 20 minutes before each building collapsed, the evacuation rate in both buildings had slowed to about one-fifth the immediately prior evacuation rate. **This suggests that for those seeking and able to reach and use undamaged exits and stairways, the egress capacity (number and width of exits and stairways) was adequate to accommodate survivors.***

In the same NIST report it states that the building design was modified such that it:

Reduced the number of required stairwells from 6 to 3, and the size of doors leading to the stairs from 44 inches to 36 inches;

These changes were due to the change to the 1968 Port Authority Code allowing the same changes to the width of the stairs just removed from the IBC. Even under the most dire of circumstances, the reduced width of the elements of the means of egress in the WTC allowed "those seeking and able to reach and use undamaged exits and stairways, the egress capacity (number and width of exits and stairways) was adequate to accommodate survivors."

The impact of this change on buildings and building design is enormous, and couldn't have happened at a worse time for the construction industry. Standard elements of the means of egress which were typically modified to allow the sprinkler increases are now restricted as follows:

Sprinklered Doors – 36" 34" clear 226 capacity
 Unsprinklered Doors – 36" 34" clear 179 capacity

Sprinklered Stairs – 44" 220 capacity
 Unsprinklered Stairs – 44" 146 capacity

Speculative office buildings which would have a single corridor, or open space and two exit stairs would have been allowed to serve a total capacity of 440 occupants; based on 100 sf. per occupant, the building could be built 44,000 sf. in area with a fire suppression system based strictly on means of egress capacity. Using the same scenario under the current IBC, the maximum occupant load served by the same door and stairs would be limited to 292 occupants; which would serve a total building area of 29,200 sf.

The result of this change will likely be less fire suppression in such office buildings as well, resulting in the following scenarios:

Office building

2009 IBC		2006 IBC	
2 exits 29,200 sf. in area	3 exits 43,800 sf. in area	2 exits 44,000 sf. in area	3 exits 66,000 sf. in area
3 stories Type IIB No fire suppression	3 stories Type IIB No fire suppression	4 stories Type IIB Fire suppression	4 stories Type IIB Fire suppression
3 stories Type IIIB No fire suppression	3 stories Type IIIA No fire suppression	4 stories Type IIIB Fire suppression	4 stories Type IIIA Fire suppression
5 stories Type IV No fire suppression	5 stories Type IV No fire suppression	6 stories Type IV Fire suppression	6 stories Type IV Fire suppression
3 stories Type VA No fire suppression	NP	4 stories Type VA Fire suppression	NP

In every case, the reductions from what was allowed in 2006 are marginal compared to what is allowed without fire suppression. 15,000 sf per floor of leasable space for Types IIB, IIB, IV and VA construction has been traded for fire suppression. These smaller buildings are less economically viable and will not be built, and yet we know that with the incentives for use of sprinklers they are a rational and safe way to build. Today, they would be required to add a third stair to achieve the same leasable building area or widen the two stairs, which would also reduce the leasable space.

I believe approving this code change will undo what is a very regressive position for the IBC. We are penalizing the users and designers by removing the one life safety system we know works virtually every time, causing undue economic pressure on development at a time when it can least afford it.

Fewer and fewer states are seeing the economic advantage of tri-annual adoption of the ICC codes for various reasons. This is an unfortunate trend that is likely to cause an undoing of the joint efforts by industry and code officials to assure as much as possible a uniform set of standards for construction in the United States. This change forges a stand that indicates a more balanced and rational approach to safety in buildings. It recognizes the overwhelming benefits of fire safety protection as part of the design and operation of buildings.

Cost: This code change will reduce the cost of construction.

PART I – IBC MEANS OF EGRESS

Public Hearing: Committee: AS AM D
 Assembly: ASF AMF DF

PART II – IFC

Public Hearing: Committee: AS AM D
 Assembly: ASF AMF DF

1005.1 (IFC [B] 1005.1); 3404.6, 3412.6.11, Table 3412.6.11(1) [IEBC [B] 303.6, 1301.6.11, Table 1301.6.11(1)]; IFC 4604.7, Table 4604.7

Proponent: Ray Grill, Arup, representing self

THIS IS A 2 PART CODE CHANGE. BOTH PARTS WILL BE HEARD BY THE MEANS OF EGRESS COMMITTEE AS 2 SEPARATE CODE CHANGES. SEE THE TENTATIVE HEARING ORDER FOR THIS COMMITTEE.

PART I – IBC MEANS OF EGRESS

Revise as follows:

1005.1 (IFC [B] 1005.1) Minimum required egress width. The means of egress width shall not be less than required by this section. The total width of means of egress in inches (mm) shall not be less than the total occupant load served by the means of egress multiplied by 0.3 inches (7.62 mm) per occupant for stairways and by 0.2 inches (5.08 mm) per occupant for other egress components. The width shall not be less than specified elsewhere in this code. Multiple means of egress shall be sized such that the loss of any one means of egress shall not reduce the available capacity to less than 50 percent of the required capacity. The maximum capacity required from any story of a building shall be maintained to the termination of the means of egress.

Exception Exceptions:

1. Means of egress complying with Section 1028.
2. For other than H and I-2 occupancies, the total width of means of egress in inches (mm) shall not be less than the total occupant load served by the means of egress multiplied by 0.2 inches (5.1 mm) per occupant for stairways and by 0.15 inches (3.8 mm) per occupant for other egress components in buildings that are provided with sprinkler protection in accordance with 903.3.1.1 or 903.3.1.2 and an emergency voice/alarm communication system in accordance with 907.5.2.2.

3404.6 (IEBC [B] 303.6) Means of egress capacity factors. Alterations to any existing building or structure shall not be subject to the egress width factors in Section 1005.1 of the International Building Code for new construction in determining the minimum egress widths or the minimum number of exits in an existing building or structure. The minimum egress widths for the components of the means of egress shall be based on the means of egress width factors in the building code under which the building was constructed, and shall be considered as complying means of egress for any alteration if, in the opinion of the code official, they do not constitute a distinct hazard to life.

3412.6.11(IEBC [B] 1301.6.11) Means of egress capacity and number. Evaluate the means of egress capacity and the number of exits available to the building occupants. In applying this section, the means of egress are required to conform to the following sections of this code: 1003.7, 1004, 1005.1, 1014.2, 1014.3, 1015.2, 1021, 1024.1, 1027.2, 1027.6, 1028.2, 1028.3, 1028.4 and 1029 [except that the minimum width required by this section shall be determined solely by the width for the required capacity in accordance with Table 3412.6.11(1)]. The number of exits credited is the number that is available to each occupant of the area being evaluated. Existing fire escapes shall be accepted as a component in the means of egress when conforming to Section 3406.

Under the categories and occupancies in Table 3412.6.11(2), determine the appropriate value and enter that value into Table 3412.7 under Safety Parameter 3412.6.11, Means of Egress Capacity, for means of egress and general safety.

2. Delete without substitution:

**TABLE 3412.6.11(1) (IEBC [B] 1301.6.11(1))
EGRESS WIDTH PER OCCUPANT SERVED**

OCCUPANCY	WITHOUT SPRINKLER SYSTEM		WITH SPRINKLER SYSTEM ^a	
	Stairways (inches per occupant)	Other egress components (inches per occupant)	Stairways (inches per occupant)	Other egress components (inches per occupant)
Occupancies other than those listed below	0.3	0.2	0.2	0.15
Hazardous: H-1, H-2, H-3 and H-4	0.7	0.4	0.3	0.2
Institutional: I-2	NA	NA	0.3	0.2

For SI: 1 inch = 25.4 mm. NA = Not applicable.

a. Buildings equipped throughout with an automatic sprinkler system in accordance with Section 903.3.1.1 or 903.3.1.2.

Revise as follows:

**TABLE 3412.6.11(2) (IEBC [B] TABLE 1301.6.11(2))
MEANS OF EGRESS VALUES**
(No change to table)

PART II – IFC

Delete without substitution:

4604.7 Minimum required egress width. The means of egress width shall not be less than as required by the code under which constructed but not less than as required by this section. The total width of means of egress in inches (mm) shall not be less than the total occupant load served by the means of egress multiplied by the factors in Table 4604.7 and not less than specified elsewhere in this section. Multiple means of egress shall be sized such that the loss of any one means of egress shall not reduce the available capacity to less than 50 percent of the required capacity. The maximum capacity required from any story of a building shall be maintained to the termination of the means of egress.

**TABLE 4604.7
EGRESS WIDTH PER OCCUPANT SERVED**

OCCUPANCY	WITHOUT SPRINKLER SYSTEM		WITH SPRINKLER SYSTEM ^a	
	Stairways (inches per occupant)	Other egress components (inches per occupant)	Stairways (inches per occupant)	Other egress components (inches per occupant)
Occupancies other than those listed below	0.3	0.2	0.2	0.15
Hazardous: H-1, H-2, H-3 and H-4	0.7	0.4	0.3	0.2
Institutional: I-2	NA	NA	0.3	0.2

For SI: 1 inch = 25.4 mm. NA = Not applicable.

a. Buildings equipped throughout with an automatic sprinkler system in accordance with Section 903.3.1.1 or 903.3.1.2.

(Renumber subsequent sections)

Reason: The egress factors for sprinklered buildings were eliminated during the last cycle with no technical justification. The exception reinstates the egress factors for sprinklers buildings but also would require an emergency voice/alarm communication system (EVAC) to be provided.

The EVAC system provides the ability to communicate instructions to occupants that would facilitate evacuation or relocation that may be necessary in fire or other emergencies. This would also lead to more efficient use of the egress system.

The original submitter of this code change had also submitted a code change (E17-07/08) to reduce the occupant load in office buildings by changing the occupant load factor from 1/100 sq.ft. to 1/175 sq.ft. The change in occupant load factor was rejected even though that proposal had a scientific study published by NIST to back the proposal.

Cost Impact: The code change proposal will not increase the cost of construction.

PART I – IBC MEANS OF EGRESS

Public Hearing: Committee: AS AM D
 Assembly: ASF AMF DF

PART II – IFC

Public Hearing: Committee: AS AM D
 Assembly: ASF AMF DF

ICCFILENAME:Grill-E1-1005.1

E22–09/10

1004.5, 1005.1 (IFC [B] 1004.5, 1005.1)

Proponent: Lawrence G. Perry, AIA, representing Building Owners and Managers Association (BOMA) International

Revise as follows:

~~**1005.1 (IFC [B] 1005.1) Minimum required egress width.** The means of egress width shall not be less than required by this section. The total width of means of egress in inches (mm) shall not be less than the total occupant load served by the means of egress multiplied by 0.3 inches (7.62 mm) per occupant for stairways and by 0.2 inches (5.08 mm) per occupant for other egress components. The width shall not be less than specified elsewhere in this code. Multiple means of egress shall be sized such that the loss of any one means of egress shall not reduce the available capacity to less than 50 percent of the required capacity. The maximum capacity required from any story of a building shall be maintained to the termination of the means of egress.~~

~~**Exception:** Means of egress complying with Section 1028.~~

1005.1 (IFC [B] 1005.1) General. The means of egress shall be sized in accordance with this section.

Exception: Means of egress complying with Section 1028.

1005.2 (IFC [B] 1005.2) Minimum width based on component. The width of egress components shall not be less than specified elsewhere in this code.

1005.3 (IFC [B] 1005.3) Capacity based on occupant load. The means of egress for any floor, room, or story shall be sized to accommodate the total occupant load, as determined by Section 1004, in accordance with the following:

1005.3.1 (IFC [B] 1005.3.1) Stairways. The capacity of means of egress stairways shall be calculated using a factor of 0.3 inches (7.62 mm) of width per person.

1005.3.2 (IFC [B] 1005.3.2) Other egress components. The capacity of means of egress components other than stairways shall be calculated using a factor of 0.2 inches (5.08 mm) of width per person.

1005.4 (IFC [B] 1005.4) Capacity based on egress path. The capacity of the means of egress required from any story of a building shall be maintained to the termination of the means of egress.

1005.5. (IFC [B] 1005.5) Distribution of egress capacity. Multiple means of egress shall be sized such that the loss of any one means of egress shall not reduce the available capacity to less than 50 percent of the required capacity.

1005.6 (IFC [B] 1005.6) Egress convergence. Where means of egress from floors above and below converge at an intermediate level, the capacity of the means of egress from the point of convergence shall not be less than the sum of the two floors.

(ReNUMBER subsequent sections.)

Delete without substitution:

~~**1004.5 (IFC [B] 1004.5) Egress convergence.** Where means of egress from floors above and below converge at an intermediate level, the capacity of the means of egress from the point of convergence shall not be less than the sum of the two floors.~~

(ReNUMBER subsequent sections.)

Reason: This proposal seeks to editorially reorganize and clarify the multiple requirements related to 'egress width' currently contained in a single paragraph in 10051, and to relocate a related provision from 1004.5 to a more logical location with other egress width/capacity provisions. No technical changes are intended by this change.

1005.1 creates a new charging paragraph.

1005.2 replaces the current second sentence of 1005.1, noting that minimum width requirements for means of egress components may be specified in other locations in the code.

1005.3 is consistent with the current egress width factors, but reorganizes the text to clarify that the total occupant load (which is determined in Section 1004) drives the capacity for which the egress width must be provided. The new text also clearly states that egress width/capacity is determined on a floor, room, and story basis.

1005.4 replaces the last sentence of current 1005.1, and notes that once a minimum capacity is required along a means of egress, it must be provided along the entire path of egress travel.

1005.5 is consistent with the current 4th sentence of 1005.1.

1005.6 relocates the provision for 'egress convergence' from 1004.5. This is really an issue of egress capacity/width, and should more appropriately be located here, instead of buried in a section on occupant load.

Cost Impact: The code change proposal will not increase the cost of construction.

Public Hearing: Committee:	AS	AM	D
Assembly:	ASF	AMF	DF

ICCFILENAME:Perry-E1-1005.1

E23-09/10

1005.1 (IFC [B] 1005.1)

Proponent: Maureen Traxler representing Washington Association of Building Officials Technical Code Development Committee

Revise as follows:

1005.1 (IFC [B] 1005.1) Minimum required egress width. The means of egress width shall not be less than required by this section. The total width of means of egress in inches (mm) shall not be less than the total occupant load served by the means of egress multiplied by 0.3 inches (7.62 mm) per occupant for stairways and by 0.2 inches (5.08 mm) per occupant for other egress components. The width shall not be less than specified elsewhere in this code. The width of exit access doorways shall not be less than the width required for doors in Section 1008. Multiple means of egress shall be sized such that the loss of any one means of egress shall not reduce the available capacity to less than 50 percent of the required capacity. The maximum capacity required from any story of a building shall be maintained to the termination of the means of egress.

Exception: Means of egress complying with Section 1028.

Reason: The IBC lacks a reasonable provision for minimum width of exit access doorways. The factors in Section 1005.1 only make sense when they are applied to situations where another code section sets forth a minimum width for an egress element, but a high number of occupants would use that element. For example, Section 1018.2 sets forth minimum corridor widths, but also states that the width shall not be less than allowed by Section 1005.1. Section 1018.2 establishes 44 inches as the minimum for most corridors, but if the corridor serves an occupant load of 300, Section 1005.1 would require 60 inches. However, the only section that addresses minimum widths for exit access doorways is 1005.1 which can produce some unacceptable results. For example, if a doorway from a space serves 50 people, Section 1005.1 says the minimum width is 10 inches.

Cost Impact: The code change proposal will not increase the cost of construction.

Public Hearing: Committee:	AS	AM	D
Assembly:	ASF	AMF	DF

ICCFILENAME: TRAXLER-E1-1005.1

E24-09/10

1005.2, 1005.2.1(New), 1005.2.2(New), 1005.2.3(New), 1005.3, 1017.1, 1018.2, 1018.3, 1023.2, 1027.5.1; (IFC [B] 1005.2, 1005.2.1(New), 1005.2.2(New), 1005.2.3(New), 1005.3, 1017.1, 1018.2, 1018.3, 1023.2, 1027.5.1)

Proponent: Gregory R. Keith, Professional heuristic Development, representing The Boeing Company

1. Revise as follows:

1005.2 (IFC [B] 1005.2) Door Encroachment. Encroachments into the required means of egress width shall be in accordance with the provisions of this section.

1005.2.1 (IFC [B] 1005.2.1) Doors. Doors, when fully opened, ~~and handrails~~ shall not reduce the required width by more than 7 inches (178 mm). Doors in any position shall not reduce the required width by more than one-half. ~~Other nonstructural projections such as trim and similar decorative features shall be permitted to project into the required width a maximum of 1½ inches (38 mm) on each side.~~

Exception Exceptions:

1. Surface-mounted latch release hardware shall be exempt from inclusion in the 7- inch maximum (178 mm) encroachment where:
 - 1.1. The hardware is mounted to the side of the door facing away from the adjacent wall where the door is in the open position; and,
 - 1.2. The hardware is mounted not less than 34 inches (865mm) nor more than 48 inches (1220 mm) above the finished floor.
2. The restrictions on a door swing shall not apply to doors within individual dwelling units and sleeping units of Group R-2 occupancies and dwelling units of Group R-3 occupancies.

2. Add new text as follows:

1005.2.2 (IFC [B] 1005.2.2) Other projections. Handrail projections shall be in accordance with the provisions of Section 1012.8. Other nonstructural projections such as trim and similar decorative features shall be permitted to project into the required width a maximum of 1½ inches (38 mm) on each side.

1005.2.3 (IFC [B] 1005.2.3) Protruding objects. Protruding objects shall comply with the applicable requirements of Section 1003.3.

3. Delete without substitution:

~~**1005.3 (IFC [B] 1005.3) Door hardware encroachment.** Surface-mounted latch release hardware shall be exempt from inclusion in the 7- inch maximum (178 mm) projection requirement of Section 1005.2 when:~~

- ~~1. The hardware is mounted to the side of the door facing the corridor width when the door is in the open position; and~~
- ~~2. The hardware is mounted not less than 34 inches (865mm) or more than 48 inches (1220 mm) above the finished floor.~~

4. Revise as follows:

1017.1 (IFC [B] 1017.1) General. Aisles serving as a portion of the exit access in the means of egress system shall comply with the requirements of this section. Aisles shall be provided from all occupied portions of the exit access which contain seats, tables, furnishings, displays and similar fixtures or equipment. Aisles serving assembly areas shall comply with Section 1028. Aisles serving reviewing stands, grandstands and bleachers shall also comply with Section 1028. The required width of aisles shall be unobstructed.

Exception: ~~Doors~~ Encroachments complying with Section 1005.2.

1018.2 (IFC [B] 1018.2) Corridor Width. The minimum ~~corridor~~ width of corridors shall be as determined in Section 1005.1, but not less than 44 inches (1118 mm).

Exceptions:

1. Twenty-four inches (610 mm)—For access to and utilization of electrical, mechanical or plumbing systems or equipment.
2. Thirty-six inches (914 mm)—With a required occupant capacity of less than 50.
3. Thirty-six inches (914mm)—Within a dwelling unit.
4. Seventy-two inches (1829 mm)—In Group E with a corridor having a required capacity of 100 or more.
5. Seventy-two inches (1829 mm)—In corridors and areas serving gurney traffic in occupancies where patients receive outpatient medical care, which causes the patient to be not capable of self-preservation.
6. Ninety-six inches (2438 mm)—In Group I-2 in areas where required for bed movement.

1018.3 (IFC [B] 1018.3) Corridor Obstruction. The required width of corridors shall be unobstructed.

Exception: ~~Doors~~ Encroachments complying with Section 1005.2.

1023.2 (IFC [B] 1023.2) Width. The minimum width of exit passageways shall be determined as specified in Section 1005.1 but such width shall not be less than 44 inches (1118 mm), except that exit passageways serving an occupant load of less than 50 shall not be less than 36 inches (914 mm) in width. The required width of exit passageways shall be unobstructed.

Exception: ~~Doors~~ Encroachments complying with Section 1005.2.

1027.5.1 (IFC [B] 1027.5.1) Width. The minimum width of egress courts shall be determined as specified in Section 1005.1, but such width shall not be less than 44 inches (1118 mm), except as specified herein. Egress courts serving Group R-3 and U occupancies shall not be less than 36 inches (914 mm) in width. The required width of egress courts shall be unobstructed to a height of 7 feet (2134 mm).

Exception: ~~Doors~~ Encroachments complying with Section 1005.2.

Where an egress court exceeds the minimum required width and the width of such egress court is then reduced along the path of exit travel, the reduction in width shall be gradual. The transition in width shall be affected by a guard not less than 36 inches (914 mm) in height and shall not create an angle of more than 30 degrees (0.52 rad) with respect to the axis of the egress court along the path of egress travel. In no case shall the width of the egress court be less than the required minimum.

Reason: This proposal is intended to clarify required width encroachment provisions. Current encroachment provisions have been reorganized into two categories: Doors and other projections. Minor editorial changes have been made in a few locations. For instance, the width determination requirements for corridors, exit passageways and egress courts have been correlated so as to contain identical charging language. It is not the intention of this proposal to change any current technical requirement. This format will coordinate with various means of egress component width provisions that generally reference Section 1005.2. Additionally, it provides a tie to Section 1003.3 that provides related requirements.

Cost Impact: The code change proposal will not increase the cost of construction.

Public Hearing: Committee:	AS	AM	D
Assembly:	ASF	AMF	DF

ICCFILENAME:Keith-E6-1005.2

E25-09/10

1005.2, 1005.4 (New), 1009.1, 1009.5, 1010.5.3, 1012.8, 1028.6 (IFC [B] 1005.2, 1005.4 (New), 1009.1, 1009.5, 1010.5.3, 1012.8, 1028.6)

Proponent: Ed Roether, Populous (Formerly HOK Sport Venue Event), representing self

1. Revise as follows:

1005.1 (IFC [B] 1005.1) Minimum required egress width. The means of egress width shall not be less than required by this section. The total width of means of egress in inches (mm) shall not be less than the total occupant load served by the means of egress multiplied by 0.3 inches (7.62 mm) per occupant for stairways and 0.2 inches (5.08 mm) per occupant for other egress components. The width shall not be less than specified elsewhere in this code. Multiple means of egress shall be sized such that the loss of any one means of egress shall not reduce the available capacity to less than 50 percent of the required capacity. The maximum capacity required from any story of a building shall be maintained to the termination of the means of egress.

Exception: Means of egress complying with Section 1028.

1005.2 (IFC [B] 1005.2) Door encroachment. Doors, when fully opened, ~~and handrails~~ shall not reduce the required means of egress width by more than 7 inches (178 mm). Doors in any position shall not reduce the required width by more than one-half. ~~Other nonstructural projections such as trim and similar decorative features shall be permitted to project into the required width a maximum of 1 1/2 inches (38 mm) on each side.~~

Exception: The restrictions on a door swing shall not apply to doors within individual dwelling units and sleeping units of Group R-2 and dwelling units of Group R-3.

1005.3 (IFC [B] 1005.3) Door Hardware encroachment. Surface-mounted latch release hardware shall be exempt from inclusion in the 7-inch (178 mm) maximum projection requirement of Section 1005.2 when:

1. The hardware is mounted to the side of the door facing the corridor width when the door is in the open position; and
2. The hardware is mounted not less than 34 inches (865 mm) or more than 48 inches (1220 mm) above the finished floor.

2. Add new text as follows:

1005.4 (IFC [B] 1005.4) Projections. Handrail projections into the required means of egress width of stairways and ramps at each handrail not exceeding 4.5 inches (114 mm) at or below the handrail height shall be permitted. Projections into the required means of egress width shall not be limited above the minimum headroom height required in Section 1003.2. Other nonstructural projections such as trim and similar decorative features shall be permitted to project into the required means of egress width a maximum of 1 1/2 inches (38 mm) on each side.

3. Revise as follows:

1009.1 (IFC [B] 1009.1) Stairway width. The width of stairways shall be determined as specified in Section 1005.1, but such width shall not be less than 44 inches (1118 mm). See Section 1007.3 for accessible means of egress stairways.

Exceptions:

1. Stairways serving an occupant load of less than 50 shall have a width of not less than 36 inches (914 mm).
2. Spiral stairways as provided for in Section 1009.9.
3. Aisle stairs complying with Section 1028.
4. Where an incline platform lift or stairway chairlift is installed on stairways serving occupancies in Group R-3, or within dwelling units in occupancies in Group R-2, a clear passage width not less than 20 inches (508 mm) shall be provided. If the seat and platform can be folded when not in use, the distance shall be measured from the folded position.
5. Projections into the required stairway width in accordance with Section 1005.4 shall be permitted.

1009.5 (IFC [B] 1009.5) Stairway landings. There shall be a floor or landing at the top and bottom of each stairway. The width of landings shall not be less than the width of stairways they serve. Every landing shall have a minimum dimension measured in the direction of travel equal to the width of the stairway. Such dimension need not exceed 48 inches (1219 mm) where the stairway has a straight run. Doors opening onto a landing shall not reduce the landing to less than one-half the required width. When fully open, the door shall not project more than 7 inches (178 mm) into a landing. When wheelchair spaces are required on the stairway landing in accordance with Section 1007.6.1, the wheelchair space shall not be located in the required width of the landing and doors shall not swing over the wheelchair spaces.

Exception Exceptions:

1. Aisle stairs complying with Section 1028.
2. Projections into the required landing width in accordance with Section 1005.4 shall be permitted.

1010.5 (IFC [B] 1010.5) Minimum dimensions. The minimum dimensions of means of egress ramps shall comply with Sections 1010.5.1 through 1010.5.3.

1010.5.1 (IFC [B] 1010.5.1) Width. The minimum width of a means of egress ramp shall not be less than that required for corridors by Section 1018.2. The clear width of a ramp between handrails, if provided, or other permissible projections shall be 36 inches (914 mm) minimum.

1010.5.2 (IFC [B] 1010.5.2) Headroom. The minimum headroom in all parts of the means of egress ramp shall not be less than 80 inches (2032 mm).

1010.5.3 (IFC [B] 1010.5.3) Restrictions. Means of egress ramps shall not reduce in width in the direction of egress travel. Projections into the required ramp and landing width are prohibited. Doors opening onto a landing shall not reduce the clear width to less than 42 inches (1067 mm).

Exception: Projections into the required means of egress width in accordance with Section 1005.4 shall be permitted.

4. Delete without substitution:

~~**1012.8 (IFC [B] 1012.8) Projections.** On ramps, the clear width between handrails shall be 36 inches (914 mm) minimum. Projections into the required width of stairways and ramps at each handrail shall not exceed 4.5 inches (114~~

mm) at or below the handrail height. Projections into the required width shall not be limited above the minimum headroom height required in Section 1009.2.

5. Revise as follows:

1028.6 (IFC [B] 1028.6) Width of means of egress for assembly. The clear width of aisles and other means of egress shall comply with Section 1028.6.1 where smoke-protected seating is not provided and with Section 1028.6.2 or 1028.6.3 where smoke-protected seating is provided. The clear width shall be measured to walls, edges of seating and tread edges ~~except for permitted projections.~~

Exception: Projections into the required aisle and other means of egress width in accordance with Section 1005.4 shall be permitted.

Reason: Handrail projections into the required means of egress width is more appropriately located in Section 1005. Also, handrails and other nonstructural projections should be relocated from door encroachment and clear width between handrails for ramps is already covered by Section 1010.5.1. Therefore, this proposal combines both the handrail projections and nonstructural projections into a new projections section under means of egress width and the duplicative clear ramp width requirement was eliminated. This proposal does not reduce the minimum ramp width requirements of Section 1010.5.1. It clarifies that handrails can project into the required means of egress width to the extent that it would not be in conflict with Section 1010.5.1. Changes to stairways and assembly aisles, where handrails are most commonly found, are revised for consistency.

Cost Impact: This code change proposal will not increase the cost of construction.

Public Hearing: Committee:	AS	AM	D
Assembly:	ASF	AMF	DF

ICCFILENAME:Roether-E3-1005.2

E26–09/10

1006.3, 1006.4 (IFC [B] 1006.3, 1006.4)

Proponent: Manny Muniz, California Deputy State Fire Marshal (Ret.), representing self

Revise as follows:

1006.3 (IFC [B] 1006.3) Illumination emergency power. The power supply for means of egress illumination shall normally be provided by the premises' electrical supply.

In the event of power supply failure, an emergency electrical system shall automatically illuminate the following areas:

1. Aisles and unenclosed egress stairways in rooms and spaces that require two or more means of egress.
2. Corridors, exit enclosures and exit passageways in buildings required to have two or more exits.

Exception: When approved by the building official, approved luminous egress path marking listed and labeled in accordance with UL 1994 and installed in accordance with the manufacturer's instructions shall be permitted to be used.

3. Exterior egress components at other than their levels of exit discharge until exit discharge is accomplished for buildings required to have two or more exits.
4. Interior exit discharge elements, as permitted in Section 1027.1, in buildings required to have two or more exits.
5. Exterior landings, as required by Section 1008.1.6, for exit discharge doorways in buildings required to have two or more exits.

The emergency power system shall provide power for a duration of not less than 90 minutes and shall consist of storage batteries, unit equipment or an on-site generator. The installation of the emergency power system shall be in accordance with Chapter 27.

1006.4 (IFC [B] 1006.4) Performance of system. Emergency lighting facilities shall be arranged to provide initial illumination that is at least an average of 1 foot-candle (11 lux) and a minimum at any point of 0.1 foot-candle (1 lux) measured along the path of egress at floor level. Illumination levels shall be permitted to decline to 0.6 foot-candle (6

lux) average and a minimum at any point of 0.06 foot-candle (0.6 lux) at the end of the emergency lighting time duration. A maximum-to-minimum illumination uniformity ratio of 40 to 1 shall not be exceeded.

Exception: When luminous egress path marking listed and labeled in accordance with UL 1994 is approved for use, it shall be continuous except as interrupted by doorways, corridors or other such architectural features in order to provide a visible delineation along the path of travel.

Reason: Means of egress illumination is intended to allow people to visibly see the means of egress by providing 1 foot-candle at the walking surface of a continuous and unobstructed path of vertical and horizontal egress travel from any occupied portion of a building or structure to a public way. This typically is accomplished with emergency light units that have a battery back-up.

Full scale tests conducted by the National Research Council of Canada and Public Works and Government Services Canada in 2006 by Dr. G. Proulx, Dr. N. Bénichou, Dr. J.K. Hum and Dr. K.N. Restivo at a 13 story office building in downtown Ottawa, Canada indicate that there may be a better and more cost-effective way to help people get out of a building.

“Comparative studies found that photoluminescent material could provide an acceptable alternative to conventional emergency lighting. Findings also indicated that the material provided a high level of performance when installed in stairwells. It was also found that low-level lighting wayguidance systems performed better than conventional emergency lighting. Studies with smoke concluded that the continuity of information of photoluminescent lines ensured an uninterrupted visual reinforcement, which provided a significant advantage over conventional emergency lighting, which became obscured by the smoke. Other advantages of the material were its easy installation in new or existing buildings, its cost-effectiveness and its low maintenance.”

“This study’s findings show the interesting potential of photoluminescent signage to assist occupant evacuation. Such signage, properly installed, can address certain deficiencies in the traditional approach of emergency lighting associated with power failure or smokeloggging of high-mounted luminaires. In order to obtain the expected outcome though, it is essential to properly install the signs, material and wayguidance components. Setting up a PLM wayfinding system appears as a cost-effective addition to, or even a potential replacement for, traditional electrical emergency lighting, since it does not consume energy, requires no wiring, minimum maintenance, and is completely reliable provided it is installed in locations where sufficient activation is ensured from normal illumination maintained on the evacuation route. The occupants’ behaviour, their speed of movement and their subjective appraisal of the material are all in concordance to indicate that PLM signs and safety wayguidance system could be a worthwhile addition improving occupant fire safety in office buildings.”

403.5.5 of the 2009 IBC and 4604.23 of the 2009 IFC already require such non-electrical luminous egress path marking systems in all new and existing buildings of Groups A, B, E, I, M and R-1 having occupied floors located more than 75 feet above the lowest level of fire department vehicle access. A key reason the ICC voting membership voted to require non-electrical luminous egress path marking systems was to insure that the egress path was visible under normal, emergency and total blackout lighting conditions so as to not rely on battery or generator backup systems that sometimes fail during an emergency.

Given that 1003.6 of the 2009 IBC and IFC already requires that “Obstructions shall not be placed in the required width of a means of egress except projections permitted by this chapter.”, the only thing that needs to be visible is the path of egress travel.

This will allow the building official to approve systems on a case by case basis as deemed appropriate as long as the luminous egress path marking system has been tested for such use in accordance with UL 1994.

A copy of this study, “Evaluation of the Effectiveness of Different Photoluminescent Stairwell Installations for the Evacuation of Office Building Occupants” has been submitted to ICC.

Cost Impact: The code change proposal will not increase the cost of construction.

Public Hearing:	Committee:	AS	AM	D
	Assembly:	ASF	AMF	DF

ICCFILENAME:Muniz-E1-1006.3

E27–09/10

1006.3 (IFC [B] 1006.3)

Proponent: Alex Boesenberg representing National Electrical Manufacturers Association

Revise as follows:

1006.3 (IFC [B] 1006.3) Illumination emergency power. The power supply for means of egress illumination shall normally be provided by the premises’ electrical supply.

In the event of power supply failure, an emergency electrical system shall automatically illuminate all of the following areas:

1. Aisles and unenclosed egress stairways in rooms and spaces that require two or more means of egress.
2. Corridors, exit enclosures and exit passageways in buildings required to have two or more exits.
3. Exterior egress components at other than their levels of exit discharge until exit discharge is accomplished for buildings required to have two or more exits.
4. Interior exit discharge elements, as permitted in Section 1027.1, in buildings required to have two or more exits.
5. Exterior landings as required by Section 1008.1.6 for exit discharge doorways in buildings required to have two or more exits.

6. Electrical rooms containing panelboards, distribution boards, switchboards, control centers and similar equipment rated 200 amperes or above.

The emergency power system shall provide power for a duration of not less than 90 minutes and shall consist of storage batteries, unit equipment or an on-site generator. The installation of the emergency power system shall be in accordance with Chapter 27.

Reason: This proposal will add electrical rooms to those spaces and areas requiring emergency lighting. Electrical rooms and areas containing the equipment described pose a unique hazard for anyone in this area. Panelboards, distribution boards, switchboards, control centers, etc. are capable of releasing tremendous amounts of energy under fault conditions, including extremely elevated temperatures, pressure waves, sound waves, molten metal, and flying objects. Compounding the hazard is that such an event often leaves the electrical room or area, and anyone in the vicinity, in complete darkness. Anyone working on or near the equipment in such a circumstance may be suffering from burns, vision loss, hearing loss, injury from flying objects, and disorientation. It is imperative that there be sufficient light so any injured person can locate and access a means to escape the area and seek help or, in a worst case scenario, allow rescue workers to quickly locate and evacuate injured persons from the area.

There are numerous cases of such catastrophic failures that leave the room or area in total darkness. Many of these instances have been documented by security cameras and can be viewed on public sites such as You-tube. The small expense of providing a minimal level of lighting can easily save a life or minimize injury. The requirement can be met by the installation of inexpensive unit lighting with integral backup power, or through the building's emergency power supply if so equipped.

Cost Impact: This proposal will increase the cost of construction.

Public Hearing: Committee:	AS	AM	D
Assembly:	ASF	AMF	DF

ICCFILENAME: BOESENBERG-E1-1006.3

E28-09/10

1006.3, 1006.4 (IFC [F] 1006.3, 1006.4)

Proponent: Gene Boecker, Code Consultants, Inc., representing Code Consultants, Inc.

Revise as follows:

1006.3 (IFC [B] 1006.3) Illumination Emergency power. The power supply for *means of egress* illumination shall normally be provided by the premises' electrical supply.

In the event of power supply failure, an emergency electrical system shall automatically illuminate all of the following areas:

1. *Aisles* and unenclosed egress *stairways* in rooms and spaces that require two or more *means of egress*.
2. *Corridors*, *exit enclosures* and *exit passageways* in buildings required to have two or more *exits*.
3. Exterior egress components at other than their *levels of exit discharge* until *exit discharge* is accomplished for buildings required to have two or more *exits*.
4. Interior *exit discharge* elements, as permitted in Section 1027.1, in buildings required to have two or more *exits*.
5. Exterior landings as required by Section 1008.1.6 for *exit discharge* doorways in buildings required to have two or more *exits*.

The emergency power system shall provide power for a duration of not less than 90 minutes and shall consist of storage batteries, unit equipment or an on-site generator. The installation of the emergency power system shall be in accordance with Chapter 27.

1006.4-1006.3.1 (IFC [B] 1006.4 1006.3.1) Performance of system Illumination level. Emergency lighting facilities shall be arranged to provide initial illumination that is at least an average of 1 foot-candle (11 lux) and a minimum at any point of 0.1 foot-candle (1 lux) measured along the path of egress at floor level. Illumination levels shall be permitted to decline to 0.6 foot-candle (6 lux) average and a minimum at any point of 0.06 foot-candle (0.6 lux) at the end of the emergency lighting time duration. A maximum-to-minimum illumination uniformity ratio of 40 to 1 shall not be exceeded.

Reason: The proposed code change eliminates confusion between Section 1006.2 and 1006.4. Section 1006.2 states that the lighting must be at least 1 foot candle when Section 1006.4 states an average. As currently written, Sections 1006.2 and 1006.4 have the same hierarchy in the Section. This leads to confusion as to which is applicable. Although the terms used in 1006.4 say "emergency lighting" it is often misunderstood as being applicable whenever a facility is subject to emergency lighting and not the specific characteristics of the lights during the emergency lighting scenario.

By making the provisions in [current] Section 1006.4 subordinate to the emergency lighting section, it clarifies the fact that the averaging method for determining compliance is only applicable to those systems with emergency power requirements; and, that the minimums in Section 1006.2 apply to "normal" lighting conditions.

The suggested change to the heading/title of Section 1006.3 makes it easier to grasp what the subject matter is; and, since the entire Section (1006) is about "illumination" it reduces redundancy in wording.

Cost Impact: The code change proposal will not increase the cost of construction.

Public Hearing: Committee:	AS	AM	D
Assembly:	ASF	AMF	DF

ICCFILENAME:Boecker-E1-1006.2_1006.4

E29–09/10

1006.4 (IFC [B] 1006.4)

Proponent: Ken Brouillette, representing City of Puyallup Washington

Revise as follows:

1006.4 (IFC [B] 1006.4) Performance of system. Emergency lighting facilities shall be arranged to provide initial illumination that is at least an average of 1 foot-candle (11 lux) and a minimum at any point of 0.1 foot-candle (1 lux) measured along the path of egress at floor level. Illumination levels shall be permitted to decline to 0.6 foot-candle (6 lux) average and a minimum at any point of 0.06 foot-candle (0.6 lux) at the end of the emergency lighting time duration. A maximum-to-minimum illumination uniformity ratio of 40:1 shall not be exceeded.

Exception: In a single story building equipped throughout with an automatic sprinkler system installed in accordance with Section 903.3.1.1 the emergency lighting facilities shall be permitted to be arranged to provide initial illumination that is at least an average of 0.5 foot-candle (5 lux) and a minimum at any point of 0.1 foot-candle (1 lux) measured along the path of egress at floor level. Illumination levels shall be permitted to decline to 0.3 foot-candle (3 lux) average and a minimum at any point of 0.06 foot-candle (0.6 lux) at the end of the emergency lighting time duration. A maximum-to-minimum illumination uniformity ratio of 40:1 shall not be exceeded.

Reason: Fire sprinkler tests have indicated that the level of smoke during evacuation is substantially decreased following the activation of an approved automatic fire sprinkler system. I have conducted many illumination tests in my jurisdiction and had to upgrade the emergency lighting facilities to comply with the current code language. This reduction will allow for adequate emergency lighting for evacuating.

Cost Impact: The code change proposal will not increase the cost of construction.

Public Hearing: Committee:	AS	AM	D
Assembly:	ASF	AMF	DF

ICCFILENAME:Brouillette-E1-1006.4

E30–09/10

1007 (IFC [B] 1007)

Proponent: Rick Lupton, City of Seattle, representing Seattle Dept of Planning & Development

Revise as follows:

1007.1 (IFC [B] 1007.1) Accessible means of egress required. Accessible means of egress shall comply with this section. Accessible spaces shall be provided with not less than one accessible means of egress. Where more than one means of egress are required by Section 1015.1 or 1021.1 from any accessible space, each accessible portion of the space shall be served by not less than two accessible means of egress.

Exceptions:

1. Accessible means of egress are not required in alterations to existing buildings.
2. One accessible means of egress is required from an accessible mezzanine level in accordance with Section ~~1007.3~~ 1007.6, ~~1007.4~~ 1007.7 or ~~1007.5~~ 1007.8.
3. In assembly areas with sloped or stepped aisles, one accessible means of egress is permitted where the common path of travel is accessible and meets the requirements in Section 1028.8.

1007.1.1 (IFC [B] 1007.1.1) Elevators required. In buildings where a required accessible floor is four or more stories above or below a level of exit discharge, at least one required accessible means of egress shall be an elevator complying with Section 1007.7.

Exceptions:

1. In buildings equipped throughout with an automatic sprinkler system installed in accordance with Section 903.3.1.1 or 903.3.1.2, an elevator shall not be required as an accessible means of egress on floors provided with a horizontal exit and located at or above the levels of exit discharge.
2. In buildings equipped throughout with an automatic sprinkler system installed in accordance with Section 903.3.1.1 or 903.3.1.2, an elevator shall not be required as an accessible means of egress on floors provided with a ramp conforming to the provisions of Section 1010.

1007.2 (IFC [B] 1007.2) Continuity and components. Each required accessible means of egress shall be continuous to a public way and ~~the components shall consist of one or more of the following components; comply with Sections 1007.3 through 1007.14~~

- ~~1. Accessible routes complying with Section 1104.~~
- ~~2. Interior exit stairways complying with Sections 1007.3 and 1022.~~
- ~~3. Exterior exit stairways complying with Sections 1007.3 and 1026.~~
- ~~4. Elevators complying with Section 1007.4.~~
- ~~5. Platform lifts complying with Section 1007.5.~~
- ~~6. Horizontal exits complying with Section 1025.~~
- ~~7. Ramps complying with Section 1010.~~
- ~~8. Areas of refuge complying with Section 1007.6.~~

Exceptions:

- ~~1. Where the exit discharge is not accessible, an exterior area for assisted rescue shall be provided in accordance with Section 4007.7-1007.10.~~
- ~~2. Where the exit stairway is open to the exterior, the accessible means of egress shall include either an area of refuge in accordance with Section 4007.6-1007.9 or an exterior area for assisted rescue in accordance with Section 4007.7-1007.10.~~

~~**1007.2.1 (IFC [B] 1007.2.1) Elevators required.** In buildings where a required accessible floor is four or more stories above or below a level of exit discharge, at least one required accessible means of egress shall be an elevator complying with Section 1007.4.~~

Exceptions:

- ~~1. In buildings equipped throughout with an automatic sprinkler system installed in accordance with Section 903.3.1.1 or 903.3.1.2, the elevator shall not be required on floors provided with a horizontal exit and located at or above the levels of exit discharge.~~
- ~~2. In buildings equipped throughout with an automatic sprinkler system installed in accordance with Section 903.3.1.1 or 903.3.1.2, the elevator shall not be required on floors provided with a ramp conforming to the provisions of Section 1010.~~

1007.3 (IFC [B] 1007.3) Accessible route of travel. An accessible route of travel shall be in accordance with Section 1104 and ICC A117.1.

1007.4 (IFC [B] 1007.4) Ramps. A ramp shall be in accordance with Section 1010.

1007.5 (IFC [B] 1007.5) Horizontal exits. A horizontal exit shall be in accordance with Section 1025.

~~**1007.3-1007.6 (IFC [B] 1007.3-1007.6) Stairways.** In order to be considered part of an accessible means of egress, an exit access stairway as permitted by Section 1016.1 or exit stairway shall have a clear width of 48 inches (1219 mm) minimum between handrails and shall either incorporate an area of refuge within an enlarged floor-level landing or shall be accessed from either an area of refuge complying with Section 4007.6-1007.9 or a horizontal exit.~~

Exceptions:

1. The area of refuge is not required at open exit access or exit stairways as permitted by Sections 1016.1 and 1022.1 in buildings that are equipped throughout with an automatic sprinkler system installed in accordance with Section 903.3.1.1 or 903.3.1.2.
2. The clear width of 48 inches (1219 mm) between handrails is not required at exit access stairways as permitted by Section 1016.1 or exit stairways in buildings equipped throughout with an automatic sprinkler system installed in accordance with Section 903.3.1.1 or 903.3.1.2.
3. Areas of refuge are not required at exit stairways in buildings equipped throughout with an automatic sprinkler system installed in accordance with Section 903.3.1.1 or 903.3.1.2.
4. The clear width of 48 inches (1219 mm) between handrails is not required for exit stairways accessed from a horizontal exit.
5. Areas of refuge are not required at exit stairways serving open parking garages.
6. Areas of refuge are not required for smoke protected seating areas complying with Section 1028.6.2.
7. The areas of refuge are not required in Group R-2 occupancies.

4007.4-1007.7 (IFC [B] 4007.4-1007.7) Elevators. In order to be considered part of an accessible means of egress, an elevator shall comply with the emergency operation and signaling device requirements of Section 2.27 of ASME A17.1. Standby power shall be provided in accordance with Chapter 27 and 3003. The elevator shall be accessed from either an area of refuge complying with Section 4007.6-1007.9 or a horizontal exit.

Exceptions:

1. Elevators are not required to be accessed from an area of refuge or horizontal exit in open parking garages.
2. Elevators are not required to be accessed from an area of refuge or horizontal exit in buildings and facilities equipped throughout with an automatic sprinkler system installed in accordance with Section 903.3.1.1 or 903.3.1.2.
3. Elevators not required to be located in a shaft in accordance with Section 708.2 are not required to be accessed from an area of refuge or horizontal exit.
4. Elevators are not required to be accessed from an area of refuge or horizontal exit for smoke protected seating areas complying with Section 1028.6.2.

4007.5-1007.8 (IFC [B] 4007.5-1007.8) Platform lifts. Platform (wheelchair) lifts shall not serve as part of an accessible means of egress, except where allowed as part of a required accessible route in Section 1109.7, ~~Items 4 through 9~~. Standby power shall be provided in accordance with Chapter 27 for platform lifts permitted to serve as part of a means of egress.

Exception: A platform lift shall not be permitted as a component of an accessible means of egress at locations where existing site constraints make use of a ramp or elevator infeasible.

4007.5.4-1007.8.1 (IFC [B] 4007.5.4-1007.8.1) Openness. Platform lifts on an accessible means of egress shall not be installed in a fully enclosed hoistway.

4007.6-1007.9 (IFC [B] 4007.6-1007.9) Areas of refuge. Every required area of refuge shall be accessible from the space it serves by an accessible means of egress. The maximum travel distance from any accessible space to an area of refuge shall not exceed the travel distance permitted for the occupancy in accordance with Section 1016.1. Every required area of refuge shall have direct access to a stairway within an exit enclosure complying with Sections 4007.3-1007.6 and 1022 or an elevator complying with Section 4007.4-1007.7. Where an elevator lobby is used as an area of refuge, the shaft and lobby shall comply with Section 1022.9 for smokeproof enclosures except where the elevators are in an area of refuge formed by a horizontal exit or smoke barrier.

Exceptions:

1. A stairway serving an area of refuge is not required to be enclosed where permitted in Sections 1016.1 and 1022.1.
2. A smokeproof enclosure is not required for an elevator lobby used as an area of refuge where the elevator is not required to be enclosed.

4007.6.4-1007.9.1 (IFC [B] 4007.6.4-1007.9.1) Size. Each area of refuge shall be sized to accommodate one wheelchair space of 30 inches by 48 inches (762 mm by 1219 mm) for each 200 occupants or portion thereof, based

on the occupant load of the area of refuge and areas served by the area of refuge. Such wheelchair spaces shall not reduce the required means of egress width. Access to any of the required wheelchair spaces in an area of refuge shall not be obstructed by more than one adjoining wheelchair space.

~~4007.6.2-1007.9.2~~ (IFC [B] ~~4007.6.2-1007.9.2~~) Separation. Each area of refuge shall be separated from the remainder of the story by a smoke barrier complying with Section 710 or a horizontal exit complying with Section 1025. Each area of refuge shall be designed to minimize the intrusion of smoke.

Exception: Areas of refuge located within an exit enclosure.

~~4007.6.3-1007.9.3~~ (IFC [B] ~~4007.6.3-1007.9.3~~) Two-way communication. Areas of refuge shall be provided with a two-way communication system complying with Sections ~~4007.8.4-1007.11.1~~ and ~~4007.8.2-1007.11.2~~.

~~4007.7-1007.10~~ (IFC [B] ~~4007.7-1007.10~~) Exterior area for assisted rescue. ~~The An~~ exterior area for assisted rescue shall ~~must~~ be open to the outside air and meet the requirements of Section ~~4007.6.4-1007.9.1~~. Separation walls shall comply with the requirements of Section 705 for exterior walls. Where walls or openings are between the area for assisted rescue and the interior of the building, the building exterior walls within 10 feet (3048 mm) horizontally of a nonrated wall or unprotected opening shall have a fire-resistance rating of not less than 1 hour. Openings within such exterior walls shall be protected by opening protectives having a fire protection rating of not less than ¾ hour. This construction shall extend vertically from the ground to a point 10 feet (3048 mm) above the floor level of the area for assisted rescue or to the roof line, whichever is lower.

~~4007.7.4-1007.10.1~~ (IFC [B] ~~4007.7.4-1007.10.1~~) Openness. The exterior area for assisted rescue shall be at least 50 percent open, and the open area above the guards shall be so distributed as to minimize the accumulation of smoke or toxic gases.

~~4007.7.2-1007.10.2~~ (IFC [B] ~~4007.7.2-1007.10.2~~) Exterior exit stairway. Exterior exit stairways that are part of the means of egress for the exterior area for assisted rescue shall provide a clear width of 48 inches (1219 mm) between handrails.

~~4007.8-1007.11~~ (IFC [B] ~~4007.8-1007.11~~) Two-way communication. A two-way communication system shall be provided at the elevator landing on each accessible floor that is one or more stories above or below the story of exit discharge complying with Sections ~~4007.8.4-1007.11.1~~ and ~~4007.8.2-1007.11.2~~.

Exceptions:

1. Two-way communication systems are not required at the elevator landing where the two-way communication system is provided within areas of refuge in accordance with Section ~~4007.6.3-1007.9.3~~.
2. Two-way communication systems are not required on floors provided with exit ramps conforming to the provisions of Section 1010.

~~4007.8.4-1007.11.1~~ (IFC [B] ~~4007.8.4-1007.11.1~~) System requirements. Two-way communication systems shall provide communication between each required location and the fire command center or a central control point location approved by the fire department. Where the central control point is not constantly attended, a two-way communication system shall have a timed automatic telephone dial-out capability to a monitoring location or 911. The two-way communication system shall include both audible and visible signals.

~~4007.8.2-1007.11.2~~ (IFC [B] ~~4007.8.2-1007.11.2~~) Directions. Directions for the use of the two-way communication system, instructions for summoning assistance via the two-way communication system and written identification of the location shall be posted adjacent to the two-way communication system.

~~4007.9-1007.12~~ (IFC [B] ~~4007.9-1007.12~~) Signage. Signage indicating special accessibility provisions shall be provided as shown:

1. Each door providing access to an area of refuge from an adjacent floor area shall be identified by a sign stating: AREA OF REFUGE.
2. Each door providing access to an exterior area for assisted rescue shall be identified by a sign stating: EXTERIOR AREA FOR ASSISTED RESCUE.

Signage shall comply with the ICC A117.1 requirements for visual characters and include the International Symbol of Accessibility. Where exit sign illumination is required by Section 1011.2, the signs shall be illuminated. Additionally,

tactile signage complying with ICC A117.1 shall be located at each door to an area of refuge and exterior area for assisted rescue in accordance with Section 1011.3.

~~1007.10-1007.13~~ (IFC [B] ~~1007.10-1007.13~~) Directional signage. Direction signage indicating the location of the other means of egress and which are accessible means of egress shall be provided at the following:

1. At exits serving a required accessible space but not providing an approved accessible means of egress.
2. At elevator landings.
3. Within areas of refuge.

~~1007.11-1007.14~~ (IFC [B] ~~1007.11-1007.14~~) Instructions. In areas of refuge and exterior areas for assisted rescue, instructions on the use of the area under emergency conditions shall be posted. The instructions shall include all of the following:

1. Persons able to use the exit stairway do so as soon as possible, unless they are assisting others.
2. Information on planned availability of assistance in the use of stairs or supervised operation of elevators and how to summon such assistance.
3. Directions for use of the two-way communications system where provided.

Reason: This proposal primarily reorganizes the section for purposes of clarity and contains no substantive changes.

Section 1007.1.1 is relocated from the subsection on continuity and components. Because section 1007.1 specifies how many accessible means of egress (AMOE) are required, it is appropriate that the requirement for an elevator, in some buildings, be included here as well. The exceptions have been modified to reflect that the exceptions apply only to the AMOE and that elevators may still be required by other sections of the code.

The laundry list of cross-references in Section 1007.2 has been omitted in favor of a reference to the series of sections detailing component and general requirements.

Section 1007.3 is added and because Section 1104 covers only location, the cross-reference to ICC A117.1 for accessible route requirements has been added.

Section 1007.4 is added for consistent treatment of accepted components.

Section 1007.5 is added for consistent treatment of accepted components.

Currently, item 10 of where platform lifts are allowed is specifically omitted in allowable locations within an AMOE. This proposal adds an exception that states the condition where a platform lift can be used as part of an accessible route of travel but not an AMOE. Adding the exception highlights the distinction.

Except for renumbering and updating references, the remainder of Section 1007 is unchanged.

Cost Impact: The code change proposal will not increase the cost of construction.

Public Hearing: Committee:	AS	AM	D
Assembly:	ASF	AMF	DF

ICCFILENAME:Lupton-E1B-AMOE Clarity

E31-09/10

1007.1 (IFC [B] 1007.1)

Proponent: Maureen Traxler representing City of Seattle, representing Seattle Dept of Planning & Development

Revise as follows:

1007.1 (IFC [B] 1007.1) Accessible means of egress required. Accessible means of egress shall comply with this section. Accessible spaces shall be provided with not less than one accessible means of egress. Where more than one means of egress are required by Section 1015.1 or 1021.1 from any accessible space, each accessible portion of the space shall be served by not less than two accessible means of egress.

Exceptions:

1. Accessible means of egress are not required in alterations to existing buildings.
2. One accessible means of egress is required from an accessible mezzanine level in accordance with Section 1007.3, 1007.4 or 1007.5.
3. In assembly areas with sloped or stepped aisles, one accessible means of egress is permitted where the common path of travel is accessible and meets the requirements in Section 1028.8.
4. In parking garages, accessible means of egress are not required to serve parking areas that do not contain accessible parking spaces or other accessible elements.

Reason: This proposal fills a gap in the current regulations. Currently, the code can be read to require all portions of all buildings to have an accessible means of egress, regardless of whether an accessible route of travel is required to a particular space. This proposal clarifies that areas in parking garages that do not have accessible parking spaces do not need to be provided with an accessible means of egress.

A requirement to provide an accessible means of egress to all portions of a parking garage would practically dictate that all multi-level parking garages be designed with level plates connected by vehicle ramps, in order to provide a complying accessible means of egress to all portions of the garage. This is often not an efficient design for parking garages. It would be very difficult for many continuously-ramped garages to comply, since the slope of any portion of the garage would be limited to 5% (1 vertical to 20 horizontal), in order to avoid providing handrails and landings every 30 inches of rise (see IBC 1010.4, 1010.8, and definition of "ramp" in IBC 1002). We do not believe the intent behind the code is to dictate the design of garages in this way. This proposal maintains the requirement for an accessible means of egress for the areas in a garage with accessible parking, but allows the rest of the garage to be designed as necessary.

Cost Impact: The code change proposal will not increase the cost of construction.

Public Hearing: Committee:	AS	AM	D
Assembly:	ASF	AMF	DF

ICCFILENAME: TRAXLER-E2-1007.1

E32–09/10

1007.1.1 (New) [IFC [B] 1007.1.1(New)]

Proponent: Rick Lupton, City of Seattle, representing Seattle Dept of Planning & Development

Revise as follows:

1007.1 (IFC [B] 1007.1) Accessible means of egress required. Accessible means of egress shall comply with this section. Accessible spaces shall be provided with not less than one accessible means of egress. Where more than one means of egress are required by Section 1015.1 or 1021.1 from any accessible space, each accessible portion of the space shall be served by not less than two accessible means of egress.

Exceptions:

1. Accessible means of egress are not required in alterations to existing buildings.
2. One accessible means of egress is required from an accessible mezzanine level in accordance with Section 1007.3, 1007.4 or 1007.5.
3. In assembly areas with sloped or stepped aisles, one accessible means of egress is permitted where the common path of travel is accessible and meets the requirements in Section 1028.8.

1007.1.1 (IFC [B] 1007.1.1) Separation of accessible means of egress. When two accessible means of egress are required, they shall be located as far apart as practical.

Reason: This proposal is intended to address a gap in the code. Currently, there is no specific code language that would prevent two accessible means of egress (AMOE) from being located immediately adjoining. Yet complying with Section 1015.2.1 would place an undue burden on the designer because there are times that an elevator is required as an AMOE and the measure between the elevator and a stair would likely control rather than the measure between stairs as intended for conventional design. According to ICC staff the intent is that two accessible means of egress be separated, but that flexibility is necessary to accommodate types and possible locations of AMOE. While this proposal does not detail exactly how far apart the two AMOE are required to be, it does state the intent yet allows the building official flexibility where necessary.

Cost Impact: The code change proposal will not increase the cost of construction.

Public Hearing: Committee:	AS	AM	D
Assembly:	ASF	AMF	DF

ICCFILENAME:Lupton-E1F-1007 Exit slip AMOE

E33–09/10

1007.1.1(New), 1007.6 (IFC [B] 1007.1.1(New), 1007.6)

Proponent: Proponent: Rick Lupton, City of Seattle, representing Seattle Dept of Planning & Development

Revise as follows:

1007.1 (IFC [B] 1007.1) Accessible means of egress required. Accessible means of egress shall comply with this section. Accessible spaces shall be provided with not less than one accessible means of egress. Where more than

one means of egress are required by Section 1015.1 or 1021.1 from any accessible space, each accessible portion of the space shall be served by not less than two accessible means of egress.

Exceptions:

1. Accessible means of egress are not required in alterations to existing buildings.
2. One accessible means of egress is required from an accessible mezzanine level in accordance with Section 1007.3, 1007.4 or 1007.5.
3. In assembly areas with sloped or stepped aisles, one accessible means of egress is permitted where the common path of travel is accessible and meets the requirements in Section 1028.8.

1007.1.1 (IFC [B] 1007.1.1) Travel distance. The maximum travel distance from any accessible space to an accessible exterior exit door, horizontal exit, exit stairway, elevator, area of refuge, or exterior area for assisted rescue shall not exceed the travel distance permitted for the occupancy in accordance with Section 1016.1.

1007.6 (IFC [B] 1007.6) Areas of refuge. Every required area of refuge shall be accessible from the space it serves by an accessible means of egress. ~~The maximum travel distance from any accessible space to an area of refuge shall not exceed the travel distance permitted for the occupancy in accordance with Section 1016.1.~~ Every required area of refuge shall have direct access to a stairway within an exit enclosure complying with Sections 1007.3 and 1022 or an elevator complying with Section 1007.4. Where an elevator lobby is used as an area of refuge, the shaft and lobby shall comply with Section 1022.1.7 for smokeproof enclosures except where the elevators are in an area of refuge formed by a horizontal exit or smoke barrier.

Exceptions:

1. A stairway serving an area of refuge is not required to be enclosed where permitted in Sections 1016.1 and 1022.1.
2. Smokeproof enclosure is not required for an elevator lobby used as an area of refuge not required to be enclosed.

Reason: This proposal relocates the travel distance provision from the area of refuge section to Section 1007.1 and applies the requirement to exits, areas of refuge or exterior areas for assisted rescue. Under the 2009 IBC areas of refuge are not required in sprinkled buildings and as a result no travel distance limitations would apply in those circumstances. As proposed, the same travel distance limitations that apply for conventional means of egress would apply to accessible means of egress (AMOE), except that the dimension may be less for the AMOE because the measurement terminates at an area of refuge or exterior area for assisted rescue. For a larger building, this may mean additional AMOE.

Cost Impact: The code change proposal will increase the cost of construction.

Public Hearing:	Committee:	AS	AM	D
	Assembly:	ASF	AMF	DF

ICCFILENAME:Lupton-E1A-1007 travel distance

E34-09/10

1007.2.1 (New), 1007.6 (IFC [B] 1007.2.1 (New), 1007.6)

Proponent: Ed Roether, Populous (Formerly HOK Sport Venue Event), representing self

Revise as follows:

1007.2 (IFC [B] 1007.2) Continuity and components. Each required accessible means of egress shall be continuous to a public way and shall consist of one or more of the following components:

1. Accessible routes complying with Section 1104.
2. Interior exit stairways complying with Sections 1007.3 and 1022.
3. Exterior exit stairways complying with Sections 1007.3 and 1026.
4. Elevators complying with Section 1007.4.
5. Platform lifts complying with Section 1007.5.
6. Horizontal exits complying with Section 1025.
7. Ramps complying with Section 1010.
8. Areas of refuge complying with Section 1007.6.

Exceptions:

1. Where the exit discharge is not accessible, an exterior area for assisted rescue shall be provided in accordance with Section 1007.7.
2. Where the exit stairway is open to the exterior, the accessible means of egress shall include either an area of refuge in accordance with Section 1007.6 or an exterior area for assisted rescue in accordance with Section 1007.7.

1007.2.1 (IFC [B] 1007.2.1) Travel distance limitations. Each required accessible means of egress component shall be so located on each story such that the maximum length of accessible exit access travel, measured from the most remote point of an accessible space to an accessible means of egress exit component, shall not exceed the travel distance permitted for the occupancy in accordance with Section 1016.1.

(Renumber subsequent sections)

1007.6 (IFC [B] 1007.6) Areas of refuge. Every required area of refuge shall be accessible from the space it serves by an accessible means of egress. ~~The maximum travel distance from any accessible space to an area of refuge shall not exceed the travel distance permitted for the occupancy in accordance with Section 1016.1.~~ Every required area of refuge shall have direct access to a stairway in an exit enclosure complying with Sections 1007.3 and 1022 or an elevator complying with Section 1007.4. Where an elevator lobby is used as an area of refuge, the shaft and lobby shall comply with Section 1022.9 for smokeproof enclosures except where the elevators are in an area of refuge formed by a horizontal exit or smoke barrier.

Exceptions:

1. A stairway serving an area of refuge is not required to be enclosed where permitted in Sections 1016.1 and 1022.1.
2. A smokeproof enclosure is not required for an elevator lobby used as an area of refuge where the elevator is not required to be enclosed.

Reason: Currently, any building that provides accessible means of egress without the use of an area of refuge has no limit to the travel distance required by the accessible means of egress system. Travel distance limits are only found in Section 1007.6. The general means of egress requires a limit to travel distance as part of a holistic approach to the exit system to address the occupant flow rates through exit components and travel speeds along its path. There is limited information on how people with disabilities impact these flow rates and travel speeds, but persons with mobility impairments typically move at a slower rate than able bodied people. The exit system for persons with a disability should be within the same travel distance limits as that provided others within the building. Therefore, this proposal moves the travel distance limitation requirement from that pertaining to only an area of refuge and applies it to the continuity of the overall accessible means of egress where it belongs.

Cost Impact: This code change proposal will increase the cost of construction.

Public Hearing: Committee:	AS	AM	D
Assembly:	ASF	AMF	DF

ICCFILENAME:Roether-E5-1007.2.1

E35–09/10

1007.2 (IFC [B] 1007.2)

Proponent: Anne VonWeller, Murray City, representing the Utah Chapter of the International Code Council

Revise as follows:

1007.2 (IFC [B] 1007.2) Continuity and components. Each required means of egress shall be continuous to a public way and shall consist of one or more of the following components:

1. Accessible routes complying with Section 1104.
2. Interior exit stairways complying with Sections 1007.3, 1009 and 1022.
3. Interior exit ramps complying with Sections 1010 and 1022.
4. Unenclosed exit access stairways complying with 1007.3, 1009 and Exception 3 or 4 of Section 1016.1.
5. Unenclosed exit access ramps complying with 1010 and Exception 3 or 4 of Section 1016.1.
- 3 6. Exterior exit stairways complying with Sections 1007.3, 1009 and 1026.
7. Exterior exit ramps complying with 1010 and 1026.
- 4-8. Elevators complying with 1007.4

- ~~5.9.~~ Platform lifts complying with Section 1007.5
- ~~6.10.~~ Horizontal exits complying with Section 1025.
- ~~7.~~ Ramps complying with Section 1010.
- ~~8.11.~~ Areas of refuge complying with Section 1007.6

Exceptions:

1. Where the exit discharge is not accessible, an exterior area for assisted rescue shall be provided in accordance with Section 1007.7.
2. Where the exit stairway is open to the exterior, the accessible means of egress shall include either an area of refuge in accordance with Section 1007.6 or an exterior area for assisted rescue in accordance with Section 1007.7.

Reason: In the 2009 Edition a distinction has been made between 'exit' stairways and ramps and 'exit access' stairways and ramps. In the past all of the exceptions for unenclosed stairways and ramps occurred in Section 1022.1. Now some of those exceptions are located in 1022.1 and some in 1016.1. This change is offered to lead user to the new location for the two exceptions relocated to 1016.1 and to provide consistence with changes made to the 2009 edition of the IBC regarding unenclosed exit access stairways and ramps. It also clarifies the base requirements contained in 1009 apply to the stairways in this section 1007.2.

Cost Impact: The code change proposal will not increase the cost of construction.

Public Hearing: Committee:	AS	AM	D
Assembly:	ASF	AMF	DF

ICCFILENAME:Vonweller-E4-1007.2

E36-09/10

1007.2 (IFC [B] 1007.2)

Proponent: Ed Roether, Populous (Formerly HOK Sport Venue Event), representing self

Revise as follows:

1007.2 Continuity and components. Each required accessible means of egress shall be continuous to a public way and shall consist of one or more of the following components:

1. Accessible routes complying with Section 1104.
2. Interior exit stairways complying with Sections 1007.3 and 1022.
3. Interior exit access stairways complying with Section 1007.3 and Section 1016.1, Exception 3 and 4.
- ~~3.4.~~ Exterior exit stairways complying with Sections 1007.3 and 1026.
- ~~4.5.~~ Elevators complying with Section 1007.4.
- ~~5.6.~~ Platform lifts complying with Section 1007.5.
- ~~6.7.~~ Horizontal exits complying with Section 1025.
- ~~7.8.~~ Ramps complying with Section 1010.
- ~~8.9.~~ Areas of refuge complying with Section 1007.6.

Exceptions:

1. Where the exit discharge is not accessible, an exterior area for assisted rescue shall be provided in accordance with Section 1007.7.
2. Where the exit stairway is open to the exterior, the accessible means of egress shall include either an area of refuge in accordance with Section 1007.6 or an exterior area for assisted rescue in accordance with Section 1007.7.

Reason: Exit access stairways as permitted by Section 1016.1 are not listed as a component of an accessible means of egress. Therefore their use should be included here to avoid conflict with Section 1007.3.

Cost Impact: The code change proposal will increase the cost of construction.

Public Hearing: Committee:	AS	AM	D
Assembly:	ASF	AMF	DF

ICCFILENAME:Roether-E10-1007.2

E37-09/10

1007.2, 1007.7, 1007.7.1, 1007.7.2 (IFC [B] 1007.2, 1007.7, 1007.7.1, 1007.7.2)

Proponent: Ron Clements, Chesterfield County Virginia Building Inspection Department, representing Chesterfield County Virginia Building Inspection Department

Revise as follows:

1007.2 Continuity and components. Each required accessible means of egress shall be continuous to a public way and shall consist of one or more of the following components:

1. Accessible routes complying with Section 1104.
2. Interior exit stairways complying with Sections 1007.3 and 1022.
3. Exterior exit stairways complying with Sections 1007.3 and 1026 and serving levels other than the level of exit discharge.
4. Elevators complying with Section 1007.4.
5. Platform lifts complying with Section 1007.5.
6. Horizontal exits complying with Section 1025.
7. Ramps complying with Section 1010.
8. Areas of refuge complying with Section 1007.6.
9. Exterior area for assisted rescue complying with Section 1007.7 serving exits at the level of exit discharge.

Exceptions:

1. ~~Where the exit discharge is not accessible, an exterior area for assisted rescue shall be provided in accordance with Section 1007.7.~~
2. ~~Where the exit stairway is open to the exterior, the accessible means of egress shall include either an area of refuge in accordance with Section 1007.6 or an exterior area for assisted rescue in accordance with Section 1007.7.~~

1007.7 (IFC [B] 1007.7) Exterior area for assisted rescue. The exterior area for assisted rescue ~~must be open to the outside air and~~ shall be an area provided on the exterior landing serving an exit door on an accessible route. The exterior area of assisted rescue shall meet the size and access requirements of Section 1007.6.1.

1007.7.1 (IFC 1007.7.1) Separation. ~~Separation walls shall comply with the requirements of Section 705 for exterior walls. Where walls or openings are between the area for assisted rescue and the interior of the building, the building exterior walls within 10 feet (3048 mm) horizontally of a nonrated wall or unprotected opening shall have a fire-resistance rating of not less than 1 hour. Exterior walls separating the exterior area of assisted rescue from the interior of the building shall have a minimum fire resistance rating of 1 hour, rated for exposure to fire from the inside. The fire resistance rated exterior wall construction shall extend horizontally 10 feet (3048mm) beyond the landing on either side of the landing or equivalent fire resistance rated construction is permitted to extend out perpendicular to the exterior wall 4 feet(1220 mm) minimum on the side of the landing. The fire resistance rated construction shall extend vertically from the ground to a point 10 feet (3048 mm) above the floor level of the area for assisted rescue or to the roof line, whichever is lower. Openings within such fire resistance rated exterior walls shall be protected in accordance with Section 715 by opening protectives having a fire protection rating of not less than 3/4 hour. This construction shall extend vertically from the ground to a point 10 feet (3048 mm) above the floor level of the area for assisted rescue or to the roof line, whichever is lower.~~

1007.7.4 1007.7.2 (IFC [B] 1007.7.4 1007.7.2) Openness. The exterior area for assisted rescue shall be at least 50 percent open, and the open area ~~above the guards~~ shall be so distributed as to minimize the accumulation of smoke or toxic gases.

1007.7.2 1007.7.3 (IFC [B] 1007.7.2 1007.7.3) Exterior exit stairway. Exterior ~~exit~~ stairways that are part of the means of egress for the exterior area for assisted rescue shall provide a clear width of 48 inches (1219 mm) between handrails.

Reason: The intent of this proposal is to clarify where the exterior area for assisted rescue is intended to be utilized and provide better code language for the requirements.

Section 1007.2. The addition language to item 3 is to indicate that the provisions for exterior exit stairways are for stairways from upper floors or basements, not the couple of steps somewhere along the path of exit discharge. If an area of refuge inside a building can be a component of an

accessible means of egress, the exterior area of assisted rescue should also be one of that list, thus the addition of item 9. The exceptions are no longer needed with the revisions to the list.

Section 1007.7 - The first text strike-through removed redundant language regarding openness to the exterior. The requirement for openness is provided in detail in Section 1007.7.1 therefore the statement is redundant in the first sentence of 1007.7. The added text to the first sentence clearly states that the exterior area for assisted rescue is an area on an exterior landing serving an exit door on an accessible route. This clarifies that the area is on an exterior landing, that it is served by an exit door therefore this is part of the exit discharge and that it is on an accessible route, which guarantees that there is an accessible route to get to the exterior area for assisted rescue. The current language is ambiguous about exactly how the exterior area for assisted rescue fits into the overall means of egress system.

The rest of the paragraph is split into a new section for clarity – Section 1007.7.1. The second text strike-through removes confusing text that states “building exterior walls within 10 feet (3048 mm) horizontally of a nonrated wall or unprotected opening shall have a fire-resistance rating”. That language suggests that some portion of the separation wall is non rated but the wall beyond the non rated portion is to be rated? It is very confusing text that is corrected in the following new text proposed. The new text attempts to capture the basic technical requirements of the current Section with two technical changes. The first was the added text that allows the rated construction to extend out perpendicular from the building on the end of the landing. This is a method that we have used to protect exterior areas for assisted rescue adjacent to, and within 10 feet of, loading dock doors to avoid having to provide a ¾ hour protected opening at the loading dock door. The 4 foot minimum dimension is based on the 4 foot protection required for similar types of exposure protection specified in Sections 706.5 Exception #2 and 3, and 706.5.1 exception #1. The second technical change is the requirement for the rating to be for inside exposure. This is based on the current method for prescribing exterior wall fire ratings in Section 705.5. Inside exposure is specified in this case since the protection intended is from a fire inside the building. The last change to Section 1007.7 is to refer opening protection of the fire rated construction to Section 715. Section 715 has the complete opening protection provisions necessary to properly protect the openings. Having the opening protection specification in Section 1007.7 without all of the supporting Sections provided in Section 715 is technically inaccurate. Table 715.4 requires ¾ hour protection in exterior walls so no amendment to the table is required and additionally the current text could be mis-applied to allow ¾ hour opening protection when the wall had a higher fire rating for another purpose, which would not occur with a direct reference to Section 715. This revision clarifies the original intent for the use of the exterior area of assisted rescue as a protected area serving an exit at the level of exit discharge where there is not be an accessible route to the public way.

Section 1007.7.1 (new Section 1007.7.2) has the text “above the guards” removed because the text accomplishes the performance requirement intended without that text. Additionally an exterior area for assisted rescue could be constructed without a guardrail in some circumstances such as a grade level landing that connects to the public way with a stair in the exit discharge. Lastly “guard” is not a defined term.

Section 1007.7.2 (new Section 1007.7.3) uses the term exterior “exit” stair. Exterior exit stairs are regulated by Section 1026 and are an exit component. The exterior stair serving an exterior area for assisted rescue is typically an exit discharge component. If a true Section 1026 exit stair is used to serve an exterior area for assisted rescue per 1007.2 exception #2 removal of the work “exit” would not pose a problem because the more generic term “exterior stair” could be applied to an exit stair. Based on these points “exit” is proposed to be deleted from 1007.7.2.

Cost Impact: This will reduce the cost of construction by reducing the confusion associated with interpreting the current exterior area for assisted rescue provisions.

Public Hearing:	Committee:	AS	AM	D
	Assembly:	ASF	AMF	DF

ICCFILENAME:Clements-E1-1007.7

E38–09/10

1007.2, 1007.7, 1007.7.1 (New), 1007.7.2 (IFC [B] 1007.2, 1007.7, 1007.7.1 (New), 1007.7.2)

Proponent: Ed Roether, Populous (Formerly HOK Sport Venue Event), representing self

Revise as follows:

1007.2 (IFC [B] 1007.2) Continuity and components. Each required accessible means of egress shall be continuous to a public way and shall consist of one or more of the following components:

1. Accessible routes complying with Section 1104.
2. Interior exit stairways complying with Sections 1007.3 and 1022.
3. Exterior exit stairways complying with Sections 1007.3 and 1026.
4. Elevators complying with Section 1007.4.
5. Platform lifts complying with Section 1007.5.
6. Horizontal exits complying with Section 1025.
7. Ramps complying with Section 1010.
8. Areas of refuge complying with Section 1007.6.
9. Exterior area for assisted rescue complying with 1007.7

Exceptions:

1. ~~Where the exit discharge is not accessible, an exterior area for assisted rescue shall be provided in accordance with Section 1007.7.~~
2. ~~Where the exit stairway is open to the exterior, the accessible means of egress shall include either an area of refuge in accordance with Section 1007.6 or an exterior area for assisted rescue in accordance with Section 1007.7.~~

1007.7 (IFC [B] 1007.7) Exterior area for assisted rescue. Exterior areas for assisted rescue shall be accessed by an accessible route from the area served shall be permitted in accordance with Section 1007.7.1 or 1007.7.2.

1007.7.1 (IFC [B] 1007.7.1) Level of exit discharge. Where the exit discharge does not include an accessible route from an exit located on a level of exit discharge to a public way, an exterior area of assisted rescue shall be provided on the exterior landing in accordance with Sections 1007.7.3 through 1007.7.6.

1007.7.2 (IFC [B] 1007.7.2) Stories above level of exit discharge. Where exit access from the area served is outdoor open air, an exterior area of assisted rescue is permitted as an alternative to an area of refuge. Every required exterior area of assisted rescue shall have direct access to an interior exit stairway, exterior stairway, or elevator serving as an accessible means of egress component. The exterior area of assisted rescue shall comply with Section 1007.7.3 through 1007.7.6 and shall be provided with a two-way communication system complying with Sections 1007.8.1 and 1007.8.2.

1007.7.3 (IFC [B] 1007.7.3) Size. Each exterior area for assisted rescue shall be sized to accommodate wheelchair spaces in accordance with Section 1007.6.1. The exterior area for assisted rescue must be open to the outside air and meet the requirements of Section 1007.6.1.

1007.7.4 (IFC [B] 1007.7.4) Separation. Separation walls shall comply with the requirements of Section 705 for exterior walls. Where walls or openings are between the area for assisted rescue and the interior of the building, the building exterior walls within 10 feet (3048 mm) horizontally of a nonrated wall or unprotected opening shall have a fire-resistance rating of not less than 1 hour. Openings within such exterior walls shall be protected by opening protectives having a fire protection rating of not less than 3/4 hour. This construction shall extend vertically from the ground to a point 10 feet (3048 mm) above the floor level of the area for assisted rescue or to the roof line, whichever is lower.

~~1007.7.4~~ **1007.7.5 (IFC [B] 1007.7.5) Openness.** The exterior area for assisted rescue shall be open to the outside air. The sides other than the separation walls shall be at least 50 percent open, and the open area above the guards shall be so distributed so as to minimize the accumulation of smoke or toxic gases.

~~1007.7.2~~ **1007.7.6 (IFC [B] 1007.7.6) Exterior-exit Stairway.** Exterior-exit Stairways that are part of the means of egress for the exterior area for assisted rescue shall provide a clear width of 48 inches (1219 mm) between handrails.

Exception: The clear width of 48 inches (1219 mm) between handrails is not required at stairways serving buildings equipped throughout with an automatic sprinkler system installed in accordance with Section 903.3.1.1 or 903.3.1.2.

Reason: An exterior area of assisted rescue is a component of an accessible means of egress, like other components listed. It is not an exception to a component of an accessible means of egress – it is a viable alternative to an interior area of refuge. This proposal clarifies how an exterior area of assisted rescue can serve as a component and still maintain the provisions relating to other components. With proper separation, communication and signage an exterior area of assisted rescue should not be limited to an exit discharge or an exterior exit stair. A stair complying with Section 1022 allows for an exterior stair, but it also allows for an enclosed exit stair to serve an exterior area of assisted rescue and Section 1107.4 would allow an elevator to also serve it. This option needs clarification on its use and this proposal provides that clarification.

Cost Impact: This code change proposal will increase the cost of construction.

Public Hearing: Committee:	AS	AM	D
Assembly:	ASF	AMF	DF

ICCFILENAME:Roether-E6-1007.2

E39–09/10

1007.2.1, 1007.8 (IFC [B] 1007.2.1, 1007.8)

Proponent: Curt Wiehle, Minnesota Construction Codes and Licensing Division, representing CCLD

Revise as follows:

1007.2.1 (IFC [B] 1007.2.1) Elevators required. In buildings where a required accessible floor is four or more stories above or below a level of exit discharge, at least one required accessible means of egress shall be an elevator complying with Section 1007.4.

Exceptions:

1. ~~In buildings equipped throughout with an automatic sprinkler system installed in accordance with Section 903.3.1.1 or 903.3.1.2, the elevator shall not be required on floors provided with a horizontal exit and located at or above the levels of exit discharge. The elevator shall not be required on floors provided with a horizontal exit and located at or above the levels of exit discharge provided:
 - 1.1. The building is equipped throughout with an automatic sprinkler system installed in accordance with Section 903.3.1.1 or 903.3.1.2; and,
 - 1.2. The horizontal exit provides a minimum of two distinct exits or, in addition to the horizontal exit, a second accessible means of egress is provided.~~
2. In buildings equipped throughout with an automatic sprinkler system installed in accordance with Section 903.3.1.1 or 903.3.1.2, the elevator shall not be required on floors provided with an exit ramp conforming to the provisions of Section 1010 and at least one additional accessible means of egress.

1007.8 (IFC [B] 1007.8) Two-way communication. A two-way communication system shall be provided at the elevator landing on each accessible floor that is one or more stories above or below the story of exit discharge complying with Sections 1007.8.1 and 1007.8.2.

Exceptions:

1. Two-way communication systems are not required at the elevator landing where the two-way communication system is provided within areas of refuge in accordance with Section 1007.6.3.
2. Two-way communication systems are not required at the elevator landing on floors provided with an exit ramps conforming to the provisions of Section 1010 and at least one additional accessible means of egress.

Reason: The existing exceptions assume that the horizontal exit and the ramp are always available and accessible. This cannot be guaranteed as the hazard may be blocking access to the ramp or horizontal exit. At most, only two accessible means of egress are required to be provided. The exception reduces that down to one. If the one remaining horizontal exit or ramp is not available, there is no accessible means of egress provided. The restated exceptions assume a higher probability that at least one option will be available. The same reasoning applies to the communication system.

Cost Impact: The code change proposal will increase the cost of construction.

Public Hearing:	Committee:	AS	AM	D
	Assembly:	ASF	AMF	DF

ICCFILENAME:Weihle-E2-1007.2.1

E40-09/10
1007.2.1 (IFC [B] 1007.2.1)

Proponent: Rick Lupton, City of Seattle, representing Seattle Dept of Planning & Development

Revise as follows:

1007.2.1 (IFC [B] 1007.2.1) Elevators required. In buildings where a required *accessible* floor is four or more stories above or below a *level of exit discharge*, at least one required *accessible means of egress* shall be an elevator complying with Section 1007.4.

Exceptions:

1. In buildings equipped throughout with an *automatic sprinkler system* installed in accordance with Section 903.3.1.1 or 903.3.1.2, the elevator shall not be required on floors provided with a *horizontal exit* and located at or above the *levels of exit discharge*.
2. In buildings equipped throughout with an *automatic sprinkler system* installed in accordance with Section 903.3.1.1 or 903.3.1.2, the elevator shall not be required on floors provided with a ramp conforming to the provisions of Section 1010.
3. Where rooms, spaces or floor levels are not required to be accessible or where stories are not required to be connected by an accessible route in accordance with Chapter 11, an elevator is not required to serve as part of an accessible means of egress.

Reason: Where spaces like a mechanical penthouse are not required to be accessible, then Section 1007.1 clearly does not require an accessible means of egress. But there are many locations within a building that might be required to contain accessible elements and yet are not required to be

wheelchair accessible. The 2006 IBC Commentary – Volume I explains that many of these exceptions are because of the economic impracticality in installing an elevator to serve such locations. And the ADA Title III frankly refers to this as “the elevator exemption”. These locations are clearly intended to be exempted from installing an elevator as impractical, whether the intended purpose is for an accessible route or an accessible means of egress.

Examples of where a room, space or floor level would not require an accessible route around, even spaces located 4 stories or more above or below the level of exit discharge. For example, the 2000 square foot mezzanine executive office of a five story building does not require elevator access and so, should not require an elevator as part of the accessible means of egress.

If a parking garage constructed six stories below grade serves a retail store having accessible entries at the 1st story only, then Section 1106.6 would require all the accessible parking spaces to be located at only the 1st story to provide shortest accessible route possible and none of the remaining parking garage levels would require an accessible route because they contain no accessible parking. As such, an elevator should not be a required part of an accessible means of egress.

The 2nd story of a multistory Type B penthouse dwelling unit in a high-rise apartment building is not required to be accessible if the conditions of Section 1107.7.2 are met, so an elevator should not be required as a part of the accessible means of egress within the dwelling unit.

This proposal adds exception 3 to clarify that when no accessible route is provided, then an elevator need not be provided solely for purposes of the accessible means of egress, consistent with explanations contained in the 2006 IBC Commentary under Section 1007.1.

Cost Impact: The code change proposal will not increase the cost of construction.

Public Hearing: Committee:	AS	AM	D
Assembly:	ASF	AMF	DF

ICCFILENAME:Lupton-E1E-1007 Elevator Exception

E41–09/10

1007.3, 1007.6 (IFC [B] 1007.3, 1007.6)

Proponent: Ed Roether, Populous (Formerly HOK Sport Venue Event), representing self

Revise as follows:

1007.3 (IFC [B] 1007.3) Exit Stairways. In order to be considered part of an accessible means of egress, an ~~exit access stairway as permitted by Section 1016.1~~ or exit stairway in compliance with Sections 1022 and 1026 shall have a clear width of 48 inches (1219 mm) minimum between handrails and shall either incorporate an area of refuge within an enlarged floor-level landing or shall be accessed from either an area of refuge complying with Section 1007.6 or a horizontal exit.

Exceptions:

- ~~1. The area of refuge is not required at open exit access or exit stairways as permitted by Section 1016.1 and 1022.1 in buildings that are equipped throughout with an automatic sprinkler system installed in accordance with Section 903.3.1.1 or 903.3.1.2.~~
- 1.2. The clear width of 48 inches (1219 mm) between handrails is not required at exit access stairways as permitted in Section 1016.1 or exit stairways in buildings equipped throughout with an automatic sprinkler system installed in accordance with Section 903.3.1.1 or 903.3.1.2.
- 2.3. Areas of refuge are not required at exit stairways in buildings equipped throughout with an automatic sprinkler system installed in accordance with Section 903.3.1.1 or 903.3.1.2.
- 3.4. The clear width of 48 inches (1219 mm) between handrails is not required for exit stairways accessed from a horizontal exit.
- 4.5. Areas of refuge are not required at exit stairways serving open parking garages.
- 5.6. Areas of refuge are not required for smoke protected seating areas complying with Section 1028.6.2.
- 6.7. The area of refuge are not required in Group R-2 occupancies.

1007.6 (IFC [B] 1007.6) Areas of refuge. Every required area of refuge shall be accessible from the space it serves by an accessible means of egress. The maximum travel distance from any accessible space to an area of refuge shall not exceed the travel distance permitted for the occupancy in accordance with Section 1016.1. Every required area of refuge shall have direct access to an exit stairway in an exit enclosure complying with Sections 1007.3 ~~and 1022~~ or an elevator complying with Section 1007.4. Where an elevator lobby is used as an area of refuge, the shaft and lobby shall comply with Section 1022.9 for smokeproof enclosures except where the elevators are in an area of refuge formed by a horizontal exit or smoke barrier.

Exceptions:

1. An exit stairway serving an area of refuge is not required to be enclosed where permitted in Sections ~~1016.1 and 1022.4~~ and 1026.

2. A smokeproof enclosure is not required for an elevator lobby used as an area of refuge where the elevator is not required to be enclosed.

Reason: Exit access stairways as permitted by Section 1016.1 are not listed as a component of an accessible means of egress. Therefore, either their use should be stricken from 1007.3 to avoid confusion or added as a component. This proposal deletes reference to exit access stairs consistent with the limited components since the location of exit access stairs can be wide ranging making it difficult for first responders to locate potential people waiting to be evacuated, especially in facilities where an area of refuge with two-way communication is not required or provided. Section 1007.3 exception #1 is redundant with exception #3 when the reference to exit access stairs is removed, therefore this proposal eliminates exception #1 rather than a more complex modification.

Cost Impact: This proposal will increase the cost of construction.

Public Hearing: Committee:	AS	AM	D
Assembly:	ASF	AMF	DF

ICCFILENAME:Roether-E4-1007.2

E42-09/10

1007.3 (IFC [B] 1007.3)

Reason: Curt Wiehle, Minnesota Construction Codes and Licensing Division, representing CCLD

Revise as follows:

1007.3 (IFC [B] 1007.3) Stairways. In order to be considered part of an accessible means of egress, an exit access stairway as permitted by Section 1016.1 or exit stairway shall have a clear width of 48 inches (1219 mm) minimum between handrails and shall either incorporate an area of refuge within an enlarged floor-level landing or shall be accessed from either an area of refuge complying with Section 1007.6 or a horizontal exit.

Exceptions:

- ~~1. The area of refuge is not required at open exit access or exit stairways as permitted by Sections 1016.1 and 1022.1 in buildings that are equipped throughout with an automatic sprinkler system installed in accordance with Section 903.3.1.1 or 903.3.1.2.~~
1. The clear width of 48 inches (1219 mm) between handrails is not required at exit access stairways as permitted by Section 1016.1 or exit stairways in buildings equipped throughout with an automatic sprinkler system installed in accordance with Section 903.3.1.1 or 903.3.1.2.
- ~~2.~~ 2. Areas of refuge are not required at exit stairways in buildings equipped throughout by an automatic sprinkler system installed in accordance with Section 903.3.1.1 or 903.3.1.2.
- ~~3.~~ 3. The clear width of 48 inches (1219 mm) between handrails is not required for exit stairways accessed from a horizontal exit.
- ~~4.~~ 4. Areas of refuge are not required at exit stairways serving open parking garages.
- ~~5.~~ 5. Areas of refuge are not required for smoke protected seating areas complying with Section 1028.6.2.
- ~~6.~~ 6. The areas of refuge are not required in Group R-2 occupancies.

Reason: Combining exceptions 1 and 3 is effectively an editorial change which does not affect the application of the code.

Cost Impact: The code change proposal will not increase the cost of construction.

Public Hearing: Committee:	AS	AM	D
Assembly:	ASF	AMF	DF

ICCFILENAME: Wiehle, E3-1007.3-1

E43-09/10

1007.3, 1007.4, 1007.6.2 (IFC [B] 1007.3, 1007.4, 1007.6.2)

Proponent: Rick Lupton, City of Seattle, representing Seattle Dept of Planning & Development

Revise as follows:

1007.3 (IFC [B] 1007.3) Stairways. In order to be considered part of an accessible means of egress, exit access stairway as permitted by Section 1016.1 or exit stairway shall have a clear width of 48 inches (1219 mm) minimum

between handrails and shall either incorporate an area of refuge within an enlarged floor-level landing or shall be accessed from either an area of refuge complying with Section 1007.6 or a horizontal exit.

Exceptions:

- ~~1. The area of refuge is not required at open exit access or exit stairways as permitted by Sections 1016.1 and 1022.1 in buildings that are equipped throughout with an automatic sprinkler system installed in accordance with Section 903.3.1.1 or 903.3.1.2~~
- ~~2-1.~~ The clear width of 48 inches (1219 mm) between handrails is not required at exit access stairways as permitted by Section 1016.1 or exit stairways in buildings equipped throughout with an automatic sprinkler system installed in accordance with Section 903.3.1.1 or 903.3.1.2.
- ~~3. Areas of refuge are not required at exit stairways in buildings equipped throughout with an automatic sprinkler system installed in accordance with Section 903.3.1.1 or 903.3.1.2.~~
- ~~4-2.~~ The clear width of 48 inches (1219 mm) between handrails is not required for exit stairways accessed from a horizontal exit.
- ~~5-3.~~ Areas of refuge are not required at exit stairways serving open parking garages.
- ~~6-4.~~ Areas of refuge are not required for smoke protected seating areas complying with Section 1028.6.2.
- ~~7-5.~~ The areas of refuge are not required in Group R-2 occupancies.

1007.4 (IFC [B] 1007.4) Elevators. In order to be considered part of an accessible means of egress, an elevator shall comply with the emergency operation and signaling device requirements of Section 2.27 of ASME A17.1. Standby power shall be provided in accordance with Chapter 27 and 3003. The elevator shall be accessed from either an area of refuge complying with Section 1007.6 or a horizontal exit.

Exceptions:

1. Elevators are not required to be accessed from an area of refuge or horizontal exit in open parking garages.
- ~~2. Elevators are not required to be accessed from an area of refuge or horizontal exit in buildings and facilities equipped throughout with an automatic sprinkler system installed in accordance with Section 903.3.1.1 or 903.3.1.2.~~
- ~~3-2.~~ Elevators not required to be located in a shaft in accordance with Section 708.2 are not required to be accessed from an area of refuge or horizontal exit.
- ~~4-3.~~ Elevators are not required to be accessed from an area of refuge or horizontal exit for smoke protected seating areas complying with Section 1028.6.2.

1007.6.2 (IFC [B] 1007.6.2) Separation. Each area of refuge shall be separated from the remainder of the story by a smoke barrier complying with Section 710 or a horizontal exit complying with Section 1025. Each area of refuge shall be designed to minimize the intrusion of smoke.

Exception Exceptions:

1. Areas of refuge located in buildings that are equipped throughout with an automatic sprinkler system installed in accordance with Section 903.3.1.1 or 903.3.1.2 shall not be required to be separated from the remainder of the story.
2. Areas of refuge located within an exit enclosure.

Reason: This proposal primarily regards areas of refuge in sprinkled buildings. The 2009 code exempts areas of refuge for stairs and elevators in fully sprinkled buildings. In this proposal the separation requirements are excepted where a building is fully sprinkled, but the wheelchair space and communication features of an area of refuge are maintained. The change is based on sprinklers substituting only for protection and time. Wheelchair spaces and communication are still needed and desired in order for assisted rescue, even in sprinkled buildings. As a result, an area of refuge becomes a space where a person in a wheelchair can get assistance. However, by not requiring the separation from the rest of the building, including logically the design for smoke intrusion, sprinklers are credited yet other necessary features are maintained. The proposal will not cause any conflict with the current definition of area of refuge—refer Section 1002. However, the proposal will add some cost to construction over current code requirements. The change is accomplished by deleting exceptions to Sections 1007.3 and 1007.4 and an exception is added to Section 1007.6.2, detailing separation requirements for areas of refuge.

Cost Impact: The code change proposal will increase the cost of construction.

Public Hearing:	Committee:	AS	AM	D
	Assembly:	ASF	AMF	DF

ICCFILENAME:Lupton-E1D-1007 Areas of Refuge

E44-09/10

1007.3, 1007.4 (IFC [B] 1007.3, 1007.4)

Proponent: Curt Wiehle, Minnesota Construction Codes and Licensing Division, representing CCLD

Revise as follows:

1007.3 (IFC [B] 1007.3) Stairways. In order to be considered part of an accessible means of egress, an exit access stairway as permitted by Section 1016.1 or exit stairway shall have a clear width of 48 inches (1219 mm) minimum between handrails and shall either incorporate an area of refuge within an enlarged floor-level landing or shall be accessed from either an area of refuge complying with Section 1007.6 or a horizontal exit.

Exceptions:

1. The area of refuge is not required at open exit access or exit stairways as permitted by Sections 1016.1 and 1022.1 in buildings that are equipped throughout with an automatic sprinkler system installed in accordance with Section 903.3.1.1 or 903.3.1.2.
2. The clear width of 48 inches (1219 mm) between handrails is not required at exit access or exit stairways in buildings equipped throughout with an automatic sprinkler system installed in accordance with Section 903.3.1.1 or 903.3.1.2.
3. Areas of refuge are not required at exit stairways in buildings equipped throughout by an automatic sprinkler system installed in accordance with Section 903.3.1.1 or 903.3.1.2.
4. ~~The clear width of 48 inches (1219 mm) between handrails is not required for exit stairways accessed from a horizontal exit.~~
5. ~~4.~~ Areas of refuge are not required at exit stairways serving open parking garages.
6. ~~5.~~ Areas of refuge are no required for smoke protected seating areas complying with Section 1028.6.2.
7. ~~6.~~ The areas of refuge are not required in Group R-2 occupancies.

1007.4 (IFC [B] 1007.4) Elevators. In order to be considered part of an accessible means of egress, an elevator shall comply with the emergency operation and signaling device requirements of Section 2.27 of ASME A17.1. Standby power shall be provided in accordance with Sections 2702 and 3003. The elevator shall be accessed from either an area of refuge complying with Section 1007.6 or a horizontal exit.

Exceptions:

1. Elevators are not required to be accessed from an area of refuge or horizontal exit in open parking garages.
2. Elevators are not required to be accessed from an area of refuge or horizontal exit in buildings and facilities equipped throughout by an automatic sprinkler system installed in accordance with Section 903.3.1.1 or 903.3.1.2.
3. Elevators not required to be located in a shaft in accordance with Section 707.2 are not required to be accessed from an area of refuge or horizontal exit.
4. Elevators are not required to be accessed from an area of refuge or horizontal exit for smoke protected seating areas complying with Section 1025.6.2.

Reason: The concept of "accessed from a horizontal exit" is flawed in that it assumes everyone passes through the horizontal exit. This is only true for half of the occupants of the floor (assuming the horizontal exit splits the floor in two). The stair or elevator cannot be accessed from a horizontal exit when the person and the stair or elevator are on the same side of the horizontal exit.

The criteria for accessible stairs and elevators must be maintained without regard to the horizontal exit. The horizontal exit cannot be used to eliminate the area of refuge or the width of the stair for those occupants that are already on the stair/elevator side of the horizontal exit. Each portion of the floor on either side of the horizontal exit requires two accessible means of egress per Section 1007.1; the stair/elevator (1) and the horizontal exit (2). The area of refuge and width of the stair must be maintained in order to provide a second exit in the event the hazard blocks access to the horizontal exit.

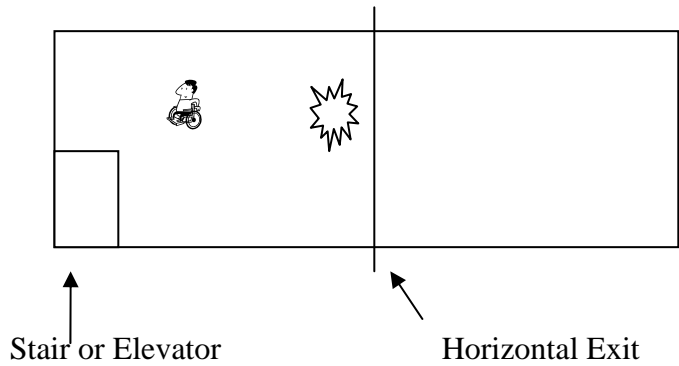

Cost Impact: The code change proposal will increase the cost of construction.

Public Hearing: Committee: AS AM D
 Assembly: ASF AMF DF

ICCFILENAME:Wiehle-E4-1007.3-2

E45–09/10

1007.3, 1007.4 (IFC [B] 1007.3, 1007.4)

Proponent: Rick Lupton, City of Seattle, representing Seattle Dept of Planning & Development

Revise as follows:

1007.3 (IFC [B] 1007.3) Stairways. In order to be considered part of an accessible means of egress, an exit access stairway as permitted by Section 1016.1 or exit stairway shall have a clear width of 48 inches (1219 mm) minimum between handrails and shall either incorporate an area of refuge within an enlarged floor-level landing or shall be accessed from either an area of refuge complying with Section 1007.6 or a horizontal exit.

Exceptions:

1. The area of refuge is not required at open exit access or exit stairways as permitted by Sections 1016.1 and 1022.1 in buildings that are equipped throughout with an automatic sprinkler system installed in accordance with Section 903.3.1.1 or 903.3.1.2.
2. The clear width of 48 inches (1219 mm) between handrails is not required at exit access stairways as permitted by Section 1016.1 or exit stairways in buildings equipped throughout with an automatic sprinkler system installed in accordance with Section 903.3.1.1 or 903.3.1.2.
3. Areas of refuge are not required at exit stairways in buildings equipped throughout with an automatic sprinkler system installed in accordance with Section 903.3.1.1 or 903.3.1.2.
4. The clear width of 48 inches (1219 mm) between handrails is not required for exit stairways accessed from a horizontal exit.
5. Areas of refuge are not required at exit stairways serving open parking garages.
6. Areas of refuge are not required for smoke protected seating areas complying with Section 1028.6.2.
7. ~~The areas~~ Areas of refuge are not required ~~in within~~ Group R-2 or R-3 ~~occupancies dwelling or sleeping units.~~

1007.4 (IFC [B] 1007.4) Elevators. In order to be considered part of an accessible means of egress, an elevator shall comply with the emergency operation and signaling device requirements of Section 2.27 of ASME A17.1. Standby power shall be provided in accordance with Chapter 27 and 3003. The elevator shall be accessed from either an area of refuge complying with Section 1007.6 or a horizontal exit.

Exceptions:

1. Elevators are not required to be accessed from an area of refuge or horizontal exit in open parking garages.
2. Elevators are not required to be accessed from an area of refuge or horizontal exit in buildings and facilities equipped throughout with an automatic sprinkler system installed in accordance with Section 903.3.1.1 or 903.3.1.2.

3. Elevators not required to be located in a shaft in accordance with Section 708.2 are not required to be accessed from an area of refuge or horizontal exit.
4. Elevators are not required to be accessed from an area of refuge or horizontal exit for smoke protected seating areas complying with Section 1028.6.2.
5. Private residence elevators are not required to be accessed from an area of refuge or horizontal exit within individual dwelling units and sleeping units of Group R-2 or R-3 occupancy.

Reason: This proposal is intended to clarify exception 7 of Section 1007.3. It is my understanding that this exception is intended to apply within individual units of a Group R-2 occupancy and not the common stairs and elevators used by all occupants of a Group R-2 occupancy. It follows, logically, that the exception should also apply to Group R-3 units and to elevators within individual units. IRC townhouses, for example, should not require areas of refuge. Common stairs and elevators can still use the sprinkler exception to areas of refuge.

Cost Impact: The code change proposal will not increase the cost of construction.

Public Hearing: Committee:	AS	AM	D
Assembly:	ASF	AMF	DF

ICCFILENAME:Lupton-E1C-1007 AOR in R2

E46-09/10

1007.6, 1007.6.2 (IFC [B] 1007.6, 1007.6.2)

Proponent: David S. Collins, FAIA, The Preview Group, Inc., representing The American Institute of Architects

Revise as follows:

1007.6 Areas of refuge. Every required area of refuge shall be accessible from the space it serves by an accessible means of egress. The maximum travel distance from any accessible space to an area of refuge shall not exceed the travel distance permitted for the occupancy in accordance with Section 1016.1. Every required area of refuge shall have direct access to a stairway within an exit enclosure complying with Sections 1007.3 and 1022 or an elevator complying with Section 1007.4. Where an elevator lobby is used as an area of refuge, the shaft and lobby shall comply with Section 1022.9 for smokeproof enclosures except where the elevators are in an area of refuge formed by a horizontal exit or smoke ~~barrier~~ partition.

Exceptions:

1. A stairway serving an area of refuge is not required to be enclosed where permitted in Sections 1016.1 and Section 1022.1.
2. A smokeproof enclosure is not required for an elevator lobby used as an area of refuge where the elevator is not required to be enclosed.

1007.6.2 Separation. Each area of refuge shall be separated from the remainder of the story by a smoke ~~barrier~~ partition having a fire-resistance rating of not less than 1 hour complying with Section ~~740~~ 711 or a horizontal exit complying with Section 1025. Each area of refuge shall be designed to minimize the intrusion of smoke.

Exception: Areas of refuge located within an exit enclosure.

Reason: The continuity of smoke barriers is required by Section 710.4 to extend from outside wall to outside wall. Smoke partitions are not required to extend from outside wall to outside wall. I do not believe the code intended areas of refuge related to elevators to be separated with smoke barriers.

Cost Impact: This will decrease the cost of construction.

Analysis: There is a code change proposal on the docket of the Fire Safety Committee to Section 710 that is proposing to revise continuity of fire barrier requirements around areas of refuge.

Public Hearing: Committee:	AS	AM	D
Assembly:	ASF	AMF	DF

ICCFILENAME:Collins-E3-1007.6

E47-09/10

1007.6 (IFC [B] 1007.6)

Proponent: Lee Kranz representing Washington Association of Building Officials (WABO), Technical Code Development Committee

Revise as follows:

1007.6 (IFC [B] 1007.6) Areas of refuge. Every required area of refuge shall be accessible from the space it serves by an accessible means of egress. The maximum travel distance from any accessible space to an area of refuge shall not exceed the travel distance permitted for the occupancy in accordance with Section 1016.1. Every required area of refuge shall have direct access to a stairway within an exit enclosure complying with Sections 1007.3 and 1022 or an elevator complying with Section 1007.4. ~~Where an elevator lobby is used as an area of refuge, the shaft and lobby shall comply with Section 1022.9 for smoke-proof enclosures except where the elevators are in an area of refuge formed by a horizontal exit or smoke barrier.~~

Exceptions:

1. A stairway serving an area of refuge is not required to be enclosed where permitted in Sections 1016.1 and 1022.1.
2. A smoke-proof enclosure is not required for an elevator lobby used as an area of refuge where the elevator is not required to be enclosed.

Reason: Areas of refuge required to serve an elevator or stair enclosure must be separated from the remainder of the building by a smoke barrier or a horizontal exit per Section 1007.6.2. As written above, this sentence would never apply as all areas of refuge are formed by either a smoke barrier or horizontal exit.

Cost Impact: The code change will not increase the cost of construction.

Public Hearing: Committee:	AS	AM	D
Assembly:	ASF	AMF	DF

ICCFILENAME: KRANZ-E4-1007.6.DOC

E48-09/10

1007.6.1 (IFC [B] 1007.6.1)

Proponent: Curt Wiehle, Minnesota Construction Codes and Licensing Division, representing CCLD

Revise as follows:

1007.6.1 (IFC [B] 1007.6.1) Size. Each area of refuge shall be sized to accommodate one wheelchair space of 30 inches by 48 inches (762 mm by 1219 mm) for each 200 occupants or portion thereof, based on the occupant load of the area of refuge and areas served by the area of refuge. Such wheelchair spaces shall not reduce the required means of egress width. Access to any of the required wheelchair spaces in an area of refuge shall not be obstructed by more than one adjoining wheelchair space. Wheelchair spaces shall be clear of any door swing. A turning space complying with ICC A117.1 shall be provided within the area of refuge.

Reason: A turning space is necessary in order to avoid entrapment inside the area of refuge and to ensure minimal maneuverability within the area of refuge. Without the turning space requirement the area of refuge could be no more than a 3' by 4' room. While it seems apparent that the door into the stairway should not overlap the wheelchair space the 2nd sentence of Section 1007.6.1 does not guarantee that.

Cost Impact: The code change proposal will increase the cost of construction.

Public Hearing: Committee:	AS	AM	D
Assembly:	ASF	AMF	DF

ICCFILENAME:Wiehle-E5-1007.6.1

E49–09/10

1007.6.2 (IFC [B] 1007.6.2)

Proponent: Curt Wiehle, Minnesota Construction Codes and Licensing Division, representing CCLD

Revise as follows:

1007.6.2 Separation Construction. ~~At a minimum, Each area of refuge shall be separated from the remainder of the story by a smoke barrier complying with Section 709 or a horizontal exit complying with Section 1025~~ provide an equivalent level of protection as the enclosure serving the area of refuge. Each area of refuge shall be designed to minimize the intrusion of smoke.

~~**Exception:** Areas of refuge located within an exit enclosure.~~

Reason: When an area of refuge is required, the rating for the construction should match the stairway or elevator shaft construction. Since smoke barrier requirements do not include criteria for 2 hour construction, the appropriate construction is a fire barrier, so only referencing Section 709 is inadequate. The fire or hazard location might block access through a horizontal exit, therefore, the area of refuge should always be required.

Cost Impact: The code change proposal will not increase the cost of construction.

Public Hearing: Committee:	AS	AM	D
Assembly:	ASF	AMF	DF

ICCFILENAME:Wiehle-E6-1007.6.2

E50–09/10

1007.8, 1007.8.2, 1007.8.3 (New), 1007.9, 1007.10 (IFC [B] 1007.8, 1007.8.2, 1007.8.3 (New), 1007.9, 1007.10)

Proponent: Curt Wiehle, Minnesota Construction Codes and Licensing Division, representing CCLD

Revise as follows:

1007.8 (IFC [B] 1007.8) Two-way communication. A two-way communication system shall be provided at the elevator landing on each accessible floor that is one or more stories above or below the story of exit discharge complying with Sections 1007.8.1 and 1007.8.2. Signage for the two-way communication system shall be provided in accordance with Section 1007.8.3.

Exceptions:

1. Two-way communication systems are not required at the elevator landing where the two-way communication system is provided within areas of refuge in accordance with Section 1007.6.3.
2. Two-way communication systems are not required on floors provided with exit ramps conforming to the provisions of Section 1010.

1007.8.1 (IFC [B] 1007.8.1) System requirements. Two-way communication systems shall provide communication between each required location and the fire command center or a central control point location approved by the fire department. Where the central control point is not constantly attended, a two way communication system shall have a timed automatic telephone dial-out capability to a monitoring location or 911. The two-way communication system shall include both audible and visible signals.

1007.8.2 (IFC [B] 1007.8.2) System Directions. Directions for the use of the two-way communication system, instructions for summoning assistance via the two-way communication system and written identification of the location shall be posted adjacent to the two-way communication system. Signage shall comply with ICC A117.1 requirements for visual characters.

1007.8.3 (IFC [B] 1007.8.3) System signage. Directional signage indicating the location of the nearest two-way communication system shall be provided at the following:

1. Exit access and exit stairways not providing a two-way communication system.
2. Elevator landings, other than levels of exit discharge, not providing a two-way communication system.

1007.9 (IFC [B] 1007.9) Signage. Signage indicating special accessibility provisions shall be provided as shown:

1. Each door providing access to an area of refuge from an adjacent floor area shall be identified by a sign stating: AREA OF REFUGE.
2. Each door providing access to an exterior area for assisted rescue shall be identified by a sign stating: EXTERIOR AREA FOR ASSISTED RESCUE.
3. Each stairway serving as part of an accessible means of egress but not accessed by an area of refuge shall be identified by a sign stating: AREA FOR ASSISTED RESCUE.
4. Each elevator landing providing a two-way communication system shall provide a sign at the two-way communication system stating: CALL STATION FOR ASSISTED RESCUE.

Signage shall comply with the ICC A117.1 requirements for visual characters and include the International Symbol of Accessibility. Where exit sign illumination is required by Section 1011.2, the signs shall be illuminated. Additionally, tactile signage complying with ICC A117.1 shall be located at each door to an area of refuge and exterior area for assisted rescue in accordance with Section 1011.3.

1007.10 (IFC [B] 1007.10) Directional signage. Directional signage indicating the location of the ~~other means of egress and which are~~ accessible means of egress shall be provided at the following:

1. At exits serving a required accessible space but not providing an approved accessible means of egress.
2. At elevator landings.
3. ~~Within areas of refuge~~ At exit access and exit stairways not providing an approved accessible means of egress.

Reason: Signage is a critical component to an effective accessible means of egress system. Directional signage to a two-way communication system may be the most important component in the egress system as this communication system is the only element provided to obtain assisted rescue.

Exception 2 at Section 1007.8 is amended because there is no assurance that if only one ramp is provided that it will not be blocked by the hazard.

When an area of refuge or other approved accessible means of egress is provided, directional signage at other noncompliant routes must be provided to direct individuals to the compliant route.

Cost Impact: The code change proposal will increase the cost of construction.

Public Hearing: Committee:	AS	AM	D
Assembly:	ASF	AMF	DF

ICCFILENAME:Wiehle-E7-1007.8

E51-09/10

1008.1.2 (IFC [B] 1008.1.2)

Proponent: Gaius G. Nelson, Architect, Nelson•Tremain Partnership, representing self

Revise as follows:

1008.1.2 (IFC [B] 1008.1.2) Door swing. Egress doors shall be of the pivoted or side-hinged swinging type.

Exceptions:

1. Private garages, office areas, factory and storage areas with an occupant load of 10 or less.
2. Group I-3 occupancies used as a place of detention.
3. Critical or intensive care patient rooms within suites of health care facilities.
4. Doors within sleeping rooms or suites of sleeping rooms in Group I-2.
- ~~4.5.~~ Doors within or serving a single dwelling unit in Groups R-2 and R-3.
- ~~5.6.~~ In other than Group H occupancies, revolving doors complying with Section 1008.1.4.1.
- ~~6.7.~~ In other than Group H occupancies, horizontal sliding doors complying with Section 1008.1.4.3 are permitted in a means of egress.
- ~~7.8.~~ Power-operated doors in accordance with Section 1008.1.4.2.
- ~~8.9.~~ Doors serving a bathroom within an individual sleeping unit in Group R-1.
- ~~9.10.~~ In other than Group H occupancies, manually operated horizontal sliding doors are permitted in a means of egress from spaces with an occupant load of 10 or less.

Doors shall swing in the direction of egress travel where serving an occupant load of 50 or more persons or a Group H occupancy.

Reason: Sliding doors are more easily operated by the disabled and present less of an obstacle than swinging doors when moving from one room to another. The NFPA 101 Life Safety Code allows sliding doors in areas serving an occupant load of fewer than 10. Refer to Chapter 18, New Health Care Occupancies.

Many state and local jurisdictions (eg. MN, WI, TX, MO, KS, IL) allow sliding doors in these occupancies.

Residents within I-2 occupancies have long term tenure, and are familiar with their living environment.

I-2 buildings are already constructed to high life safety standards.

Cost Impact: The cost of construction is potentially reduced because sliding doors allow for more useable floor space. The door approach clearances are reduced, and the door swing space is eliminated.

Public Hearing: Committee:	AS	AM	D
Assembly:	ASF	AMF	DF

ICCFILENAME:Nelson-E2-1008.1.2.2

E52–09/10

1008.1.2 (IFC [B] 1008.1.2)

Proponent: Gaius G. Nelson, Architect, Nelson•Tremain Partnership, representing self

Revise as follows:

1008.1.2 (IFC [B] 1008.1.2) Door swing. Egress doors shall be of the pivoted or side-hinged swinging type.

Exceptions:

1. Private garages, office areas, factory and storage areas with an occupant load of 10 or less.
2. Group I-3 occupancies used as a place of detention.
3. Critical or intensive care patient rooms within suites of health care facilities.
4. Doors within or serving a single dwelling unit in Groups R-2, ~~and R-3,~~ and I-1.
5. In other than Group H occupancies, revolving doors complying with Section 1008.1.4.1.
6. In other than Group H occupancies, horizontal sliding doors complying with Section 1008.1.4.3 are permitted in a means of egress.
7. Power-operated doors in accordance with Section 1008.1.4.2.
8. Doors serving a bathroom within an individual sleeping unit in Group R-1.
9. In other than Group H occupancies, manually operated horizontal sliding doors are permitted in a means of egress from spaces with an occupant load of 10 or less.

Doors shall swing in the direction of egress travel where serving an occupant load of 50 or more persons or a Group H occupancy.

Reason: Sliding doors are more easily operated by the disabled and present less of an obstacle than swinging doors when moving from one room to another. The NFPA 101 Life Safety Code allows sliding doors in areas serving an occupant load of fewer than 10. Refer to Chapter 18, New Health Care Occupancies.

Many state and local jurisdictions (e.g., MN, WI, TX, MO, KS, IL) allow sliding doors in these occupancies.

Residents within I-1 occupancies have long term tenure, and are familiar with their living environment.

I-1 buildings are already constructed to high life safety standards.

Cost Impact: The cost of construction is potentially reduced because sliding doors allow for more useable floor space. The door approach clearances are reduced, and the door swing space is eliminated.

Public Hearing: Committee:	AS	AM	D
Assembly:	ASF	AMF	DF

ICCFILENAME:Nelson-E1-1008.1.2

E53–09/10

1008.1.2 (IFC [B] 1008.1.2)

Proponent: Homer Maiel, PE, CBO, City of San Jose, representing ICC Tri-Chapter (Peninsula, East Bay, Monterey Bay)

Revise as follows:

1008.1.2 (IFC [B] 1008.1.2) Door swing. Egress doors shall be side-hinged swinging.

Exceptions:

1. Private garages, office areas, factory and storage areas with an occupant load of 10 or less.
2. Group I-3 occupancies used as a place of detention.
3. Critical or intensive care patient rooms within suites of health care facilities.
4. Doors within or serving a single dwelling unit in Groups R-2 and R-3.
5. In other than Group H occupancies, revolving doors complying with Section 1008.1.4.1.
6. In other than Group H occupancies, horizontal sliding doors complying with Section 1008.1.4.3 are permitted in a means of egress.
7. Power-operated doors in accordance with Section 1008.1.4.2.
8. Doors serving a bathroom within an individual sleeping unit in Group R-1.
9. In other than Group H occupancies, manually operated horizontal sliding doors are permitted in a means of egress from spaces with an occupant load of 10 or less.

Doors shall swing in the direction of egress travel where serving a room or area containing an occupant load of 50 or more persons or a Group H occupancy.

Reason: The current wording of the second paragraph of Section 1008.1.2 can result in an incorrect interpretation of the intent of this section. The present wording can be interpreted to mean that the *door* itself must serve a tributary occupant load of 50 or more. However, the 2006 IBC Commentary for this code section located on page 10-40, clearly specifies that a side-hinged door must swing in the direction of egress travel where the required occupant capacity *of the room* is 50 or more. The 2006 IBC Commentary goes on to give the example of a room with 99 occupants and two exit doors where each door would individually serve less than 50, but the intent is that both doors must swing in the direction of egress. Because of this published conclusion of the intent of this paragraph, the current wording would benefit from the proposed change so that it would no longer be subject to an incorrect interpretation.

Cost Impact: The code change proposal will not increase the cost of construction.

Public Hearing: Committee:	AS	AM	D
Assembly:	ASF	AMF	DF

ICCFILENAME:Maiei-E4-1008.1.2

E54–09/10

1008.1.4.3 (IFC [B] 1008.1.4.3)

Proponent: Gregory J. Cahanin, Cahanin Fire & Code Consulting Representing the Smoke Safety Council

Revise as follows:

1008.1.4.3 (IFC [B] 1008.1.4.3) Horizontal or vertical sliding doors. In other than Group H occupancies, horizontal or vertical sliding doors permitted to be a component of a *means of egress* in accordance with Exception 6 to Section 1008.1.2 shall comply with all of the following criteria:

1. The doors shall be power operated and shall be capable of being operated manually in the event of power failure.
2. The doors shall be openable by a simple method from both sides without special knowledge or effort.
3. The force required to operate the door shall not exceed 30 pounds (133 N) to set the door in motion and 15 pounds (67 N) to close the door or open it to the minimum required width.
4. The door shall be openable with a force not to exceed 15 pounds (67 N) when a force of 250 pounds (1100 N) is applied perpendicular to the door adjacent to the operating device.
5. The door assembly shall comply with the applicable *fire protection rating* and, where rated, shall be self-closing or automatic closing by smoke detection in accordance with Section 715.4.8.3, shall be installed in accordance with NFPA 80 and shall comply with Section 715.
6. The door assembly shall have an integrated standby power supply.
7. The door assembly power supply shall be electrically supervised.
8. The door shall open to the minimum required width within 10 seconds after activation of the operating device.

Reason: Doors other than side-swinging doors have had special classifications for some time- turnstiles, revolving doors, and horizontal sliding doors suitable for egress are the most common. Horizontal sliding door classifications for egress were first developed more than 2 decades ago for Won Door's then unique bi-fold door and wall system. Since that time there have been multiple manufacturers whose opening protectives are not side swinging, but meet the same performance and safety requirements for horizontal sliding doors while have a different orientation. This change is

recognition of any door system orientation that meets the specific operational requirements that have been successfully in place for horizontal doors is acceptable. Further, it does not matter if the door slides, folds, or rolls up- only that it perform successfully for safe egress. There is no change in the testing or operational requirements- only a clarification of orientation.

Cost Impact: The code change proposal will not increase the cost of construction.

Public Hearing: Committee:	AS	AM	D
Assembly:	ASF	AMF	DF

ICCFILENAME:Cahanin-E1-1008.1.4.3

E55-09/10

1008.1.4.3 (IFC [B] 1008.1.4.3)

Proponent: John W. Park, John Park consulting representing Won-Door Corporation.

Revise as follows:

1008.1.4.3 (IFC [B] 1008.1.4.3) Horizontal sliding doors. In other than Group H occupancies, horizontal sliding doors permitted to be a component of a means of egress in accordance with Exception 6 to Section 1008.1.2 shall comply with all of the following:

1. The doors shall be power operated and shall be capable of being operated manually in the event of power failure.
2. The doors shall be openable by a simple method from both sides without special knowledge or effort.
3. The force required to operate the door shall not exceed 30 pounds (133 N) to set the door in motion and 15 pounds (67 N) to close the door or open it to the minimum required width.
4. The door shall be openable with a force not to exceed 15 pounds (67 N) when a force of 250 pounds (1100 N) is applied perpendicular to the door adjacent to the operating device.
5. The door assembly shall comply with the applicable fire protection rating and, where rated, the door assembly shall comply with all of the following:
 - 5.1 Be self-closing or automatic closing by smoke detection in accordance with Section 715.4.8.3,
 - 5.2 The door assembly shall be installed in accordance with NFPA 80, and
 - 5.3 The door assembly shall comply with Section 715, and
 - 5.4 Electronic controls for horizontal sliding doors that include closing and signaling functions shall be tested and listed in accordance with UL 864.
6. The door assembly shall have an integrated standby power supply.
7. The door assembly power supply shall be electrically supervised.
8. The door shall open to the minimum required width within 10 seconds after activation of the operating device.

Reason: Self closing or automatic closing devices referenced need to work seamlessly with fire alarm systems, including providing feedback signals to achieve joint control with the fire control center. UL 864, *Standard for Control Units and Accessories for Fire Alarm Systems* is a nationally recognized standard that provides appropriate tests and guidelines to assure compatibility. It further deals with critical functions such as alarm verification, endurance, life safety networks, notification, power supplies, resets, risk of electrical shock, risk of fire, standby power sources, storage batteries, dual power source systems, supervisory signals, and trouble signals. Since the closing device essentially releases the door from its open to closed position on receipt of a signal from the fire alarm system, they should be evaluated to the 864 standard under the "Releasing Device" category. Holding said closing devices to nationally recognized standards ensures consistency and compatibility for these types of products.

Separating the requirements for compliance with section 715 as well as being installed in accordance with NFPA 80 breaks out the separate requirements and makes for better understanding.

Cost Impact: The code change proposal will increase the cost of construction.

Public Hearing: Committee:	AS	AM	D
Assembly:	ASF	AMF	DF

ICCFILENAME:Park-E1-1008.1.4.3

E56-09/10

1008.1.4.4, Chapter 35 (IFC [B] 1008.1.4.4, Chapter 45)

Proponent: Kurt Roeper, representing Ingersoll Rand

1. Revise as follows:

1008.1.4.4 Access Controlled Egress Doors. The entrance doors in a means of egress in buildings with an occupancy in Groups A, B, E, I-2, M, R-1, or R-2 and entrance doors to tenant spaces in occupancies in groups A, B, E, I-2, M, R-1, or R-2 are permitted to be equipped with an approved entrance and egress access control system, listed in accordance with ANSI / UL 294, which shall be installed in accordance with all of the following criteria;

1. A sensor shall be provided on the egress side arranged to detect an occupant approaching the doors. The doors shall be arranged to unlock by a signal from or loss of power to the sensor.
2. Loss of power to that part of the access control system which locks the doors shall automatically unlock the doors.
3. The doors shall be arranged to unlock from a manual unlocking device located 40 inches to 48 inches (1016mm to 1219 mm) vertically above the floor and within 5 feet (1524 mm) of the secured doors. Ready access shall be provided to the manual unlocking device and the device shall be clearly identified by a sign that reads "PUSH TO EXIT." When operated, the manual unlocking device shall result in direct interruption of power to the lock— independent of the access control system electronics—and the doors shall remain unlocked for a minimum of 30 seconds.
4. Activation of the building fire alarm system, if provided, shall automatically unlock the doors, and the doors shall remain unlocked until the fire alarm system has been reset.
5. Activation of the building automatic sprinkler or fire detection system, if provided, shall automatically unlock the doors. The doors shall remain unlocked until the fire alarm system has been reset.
6. Entrance doors in buildings with an occupancy in Group A, B, E or M shall not be secured from the egress side during periods that the building is open to the general public.

2. Add new standard to Chapter 35 (IFC [B] Chapter 45) as follows:

UL – Underwriters Laboratories, Inc.

ANSI / UL 294-1999 – Access Control System Units with revisions through 2009

Reason: The increasing technological complexity of wired and wireless access control systems necessitates a baseline level of system performance and reliability be established via testing and listing to a nationally recognized standard. This proposal does not remove the AHJ's right to approve such systems, but supplements their evaluation by requiring listing to a nationally recognized standard. The existing requirements of the code do not provide any foundation from which an AHJ can assess electronic systems and communication devices used in access / egress control systems.

Cost Impact: The code change proposal will not increase the cost of construction.

Analysis: A review of the standard proposed for inclusion in the code, UL 294, for compliance with ICC criteria for referenced standards given in Section 3.6 of Council Policy #CP 28 will be posted on the ICC website on or before September 24, 2009.

Public Hearing:	Committee:	AS	AM	D
	Assembly:	ASF	AMF	DF

ICCFILENAME:Roepe-E1-1008.1.4.4

E57–09/10

1008.1.5, 1008.1.7(IFC [B] 1008.1.5, 1008.1.7)

Proponent: Julie Ruth, PE, JRuth Code Consulting, representing American Architectural Manufacturers Association

1. Revise as follows:

1008.1.5 (IFC [B] 1008.1.5) Floor elevation. There shall be a floor or landing on each side of a door. Such floor or landing shall be at the same elevation on each side of the door. Landings shall be level except for exterior landings, which are permitted to have a slope not to exceed 0.25 unit vertical in 12 units horizontal (2-percent slope). Thresholds at doorways shall not exceed ¾ inch (19.1 mm) in height for sliding doors serving dwelling units or ½ inch (12.7 mm) for other doors. Floor level changes greater than ¼ inch (6.4 mm) at the required exit door, including those due to raised thresholds, shall be beveled with a slope not greater than one unit vertical in two units horizontal (50-percent slope).

Exceptions:

1. Doors serving individual dwelling units in Groups R-2 and R-3 where the following apply:
 - 1.1. A level floor or landing on each side of a door is not required for a door is permitted to open at the top step of an interior flight of stairs, provided the door does not swing over the top step.
 - 1.2. Screen doors and storm doors are permitted to swing over stairs or landings.

2. Exterior doors as provided for in Section 1003.5, Exception 1, and Section 1020.2, which are not on an accessible route.
3. In Group R-3 occupancies, and dwelling units in Group R-2 occupancies, where the following apply:
 - 3.1. Are not required to be Accessible units, Type A units or Type B units,
 - 3.2. The exterior floor or landing at an exterior doorway shall is not be more than 7 ¾ inches (197 mm) below the top of the threshold, provided and
 - 3.3. The exterior door, other than an exterior storm or screen door, does not swing over the landing.

Thresholds at doorways shall not exceed ¾ inch (19.1 mm) in height above the interior finished floor for sliding doors serving dwelling units or ½ inch (12.7 mm) for other doors. If the top of the threshold at these doors is more than ¼ inch (6.4 mm) above the interior finished floor the threshold or floor shall be beveled with a slope towards the interior not greater than one unit vertical in two units horizontal (50 percent slope).

4. Variations in elevation due to differences in finish materials, but not more than ½ inch (12.7 mm).
5. Exterior decks, patios or balconies that are part of Type B dwelling units, have impervious surfaces and meet the following:
 - 5.1. ~~that~~ Are not more than 4 inches (102 mm) below the finished floor level of the adjacent interior space of the dwelling unit,
 - 5.2. Are not more than 4 ½ inches below the top of the threshold of any side swinging doors between the exterior deck, patio or balcony and the adjacent interior space, and
 - 5.3. Are not more than 4 ¾ inches below the top of the threshold of any sliding doors between the exterior deck, patio or balcony and the adjacent interior space.

Thresholds at doorways shall not exceed ¾ inch (19.1 mm) in height above the interior finished floor for sliding doors serving dwelling units or ½ inch (12.7 mm) for other doors. If the top of the threshold at these doors is more than ¼ inch (6.4 mm) above the interior finished floor the threshold or floor shall be beveled with a slope towards the interior not greater than one unit vertical in two units horizontal (50 percent slope).

2. Delete without substitution:

~~**1008.1.7 Thresholds.** Thresholds at doorways shall not exceed ¾ inch (19.1 mm) in height for sliding doors serving dwelling units or ½ inch (12.7 mm) for other doors. Raised thresholds and floor level changes greater than ¼ inch (6.4 mm) at doorways shall be beveled with a slope not greater than one unit vertical in two units horizontal (50-percent slope).~~

~~**Exception:** The threshold height shall be limited to 7 ¾ inches (197 mm) where the occupancy is Group R-2 or R-3; the door is an exterior door that is not a component of the required means of egress; the door, other than an exterior storm or screen door does not swing over the landing or step; and the doorway is not on an accessible route as required by Chapter 11 and is not part of an Accessible unit, Type A unit or Type B unit.~~

(Renumber subsequent sections)

Reason: This proposal seeks to clarify the requirements of the International Building Code with regards to floor elevations and thresholds at and adjacent to exterior doorways, by combining the requirements that are currently in two sections into one section. The 2009 IBC deals with floor elevations at doorways separately from thresholds, as did the previous editions of the IBC. This has resulted in confusion.

The primary concern with regards to egress through a door is the changes in elevation that occurs as the building occupant passes from one space on one side of the door to another space on the other side. This proposal seeks to address that transition in one section.

When the wind blows across the surface of an exterior wall a phenomenon known as pressure differentiation occurs between the surface of that wall and the wall cavity. The exact nature of the differentiation, both with regards to whether or not it is positive or negative, and its magnitude, will depend upon the surface of the exterior wall itself, openings that occur between the wall cavity and the exterior surface, the direction the wind is blowing and the speed of the wind. If the pressure in the wall cavity is less than the pressure on the exterior surface, then exterior air will be drawn into the wall cavity. If the exterior air is laden with moisture, then that moisture will be drawn into the cavity as well.

The exact nature of this pressure differentiation, and particularly its potential magnitude, is a subject that AAMA and its members have been studying for decades. AAMA/WDMA/CSA 101/I.S.2/A440 requires exterior wall fenestrations to be tested for water infiltration at a difference in pressure between the interior side of the wall and the exterior side of the wall of either 15 or 20% of structural design pressure, with a cap of 12 psf. In areas where the exterior design wind speed is 90 mph (the majority of the U.S.), the resultant design wind pressure on the exterior surface of the wall of a building under 60 feet in height can be as great as +/- 37 psf, with resultant design pressure differential for water infiltration as high as 7.4 psf. This translates into 1.42 inches of water when measured using a manometer. A threshold height of 1/2 inch or 3/4 inch, as is currently required by Section 1008.1.7 in combination with Section 1008.1.5 and as illustrated in the sketch below, is not adequate to resist this.

1008.1.5

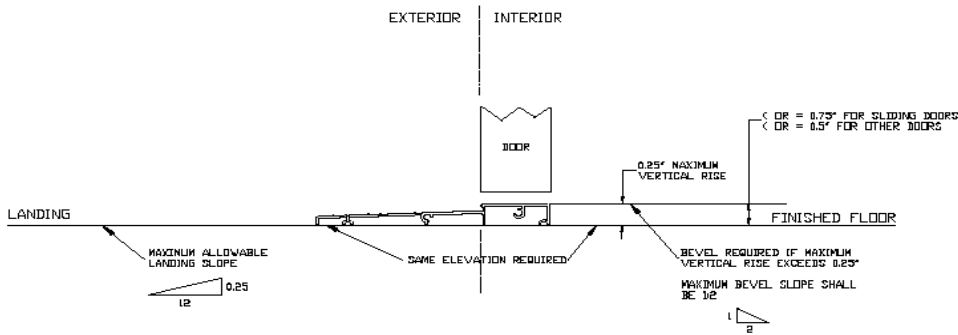

Moreover, extreme wind events that have occurred within the U.S. over the past decade appear to indicate that while the design wind pressure calculated using the three second gust model of ASCE 7 - 98 and later editions appear to be adequate for determining required structural load capacity (at least for fenestration) such may not be the case with regards to the pressure differential assumed between the interior and exterior side of the wall for water infiltration. In other words, we know that 3/4 inch is inadequate to resist water penetration through the wall for the majority of the country. What we don't yet know is what the appropriate number should be. AAMA is currently engaged in further research on this topic.

Even though a difference in floor elevation due to floor finish materials is permitted by exception 4 to Section 1008.1.5, the threshold height is still limited to 1/2 inch for swinging doors or 3/4 inch for sliding doors, by Section 1008.1.7. As shown in the sketch below, this slight difference in floor elevation is not adequate to address the water pressure differentiation that could be experienced at the sill of these exterior doors.

1008.1.5 - EXCEPTION 4

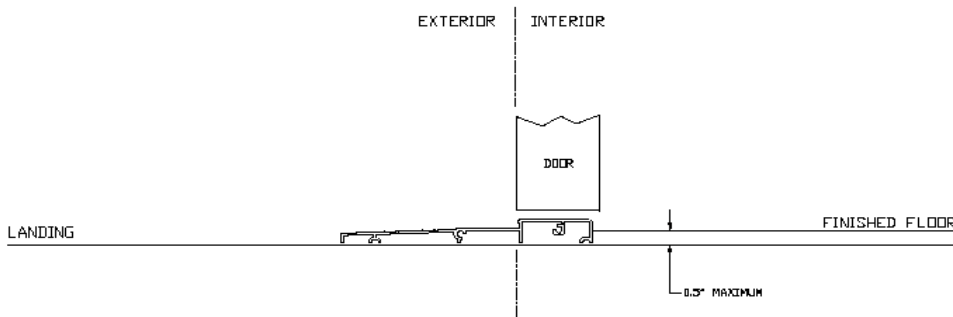

Currently the IBC and IRC permits thresholds greater than 3/4 inch in height for exterior doors that are not required egress doors, do not swing over a landing and are not part of an Accessible unit, Type A or Type B unit, or in a doorway that is on an accessible route, as required by Chapter 11 of the IBC. Such thresholds are permitted by the exception to Section 1008.1.7 to be up to 7 3/4 inches in height.

The intent of the exception to Section 1008.1.7, when it was proposed by the fenestration industry in the first years of the IBC, was to permit thresholds up to 7 3/4 inches in height to be incorporated into the 7 3/4 inches step down in height that is permitted at the door by Exception 3 to Section 1008.1.5. A tie between these two sections, however, does not currently exist. As a result, there has been confusion about the proper use of this exception. By bringing the requirements for threshold height into Section 1008.1.5 the tie between threshold height and floor elevations on either side of the door is more firmly established.

This proposal also addresses concerns that have been expressed that the current exception does not appropriately limit the height of the threshold above the interior floor, by repeating the current provisions on Section 1008.1.5 in Exception 3. The result is shown in the sketch below.

EXCEPTION 3

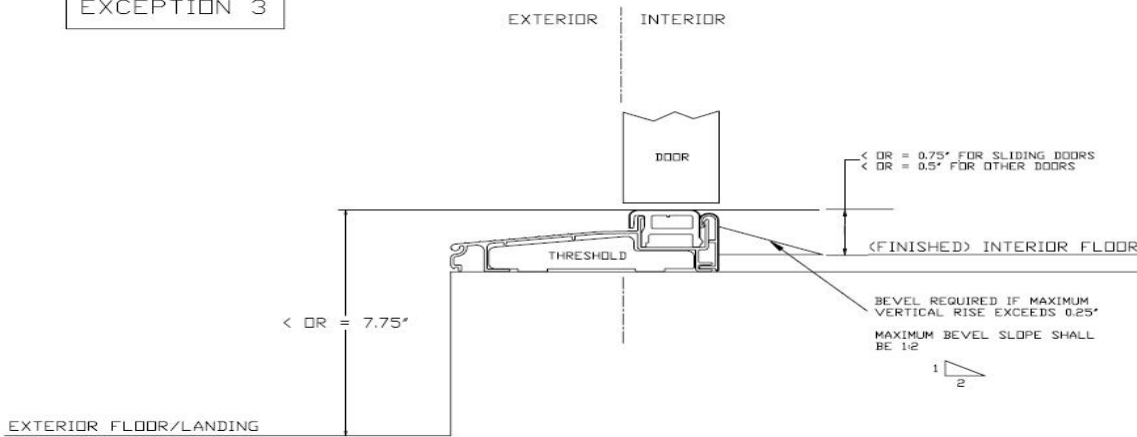

Finally, this proposal addresses the same concern regarding potential water infiltration of Type B dwelling units by bringing revising Exception 5 similarly to Exception 3. The revisions proposed to Exception 3 and Exception 5 to Section 1008.1.5 would permit thresholds higher than 1/2 inch or 3/4 inch to be used, provided the extra height is incorporated into the height difference between the interior and exterior floors that is already permitted by these exceptions, and the current height of threshold above the interior floor surface requirements are maintained. The sketch below illustrates the provisions of proposed Exception 5.

EXCEPTION 5

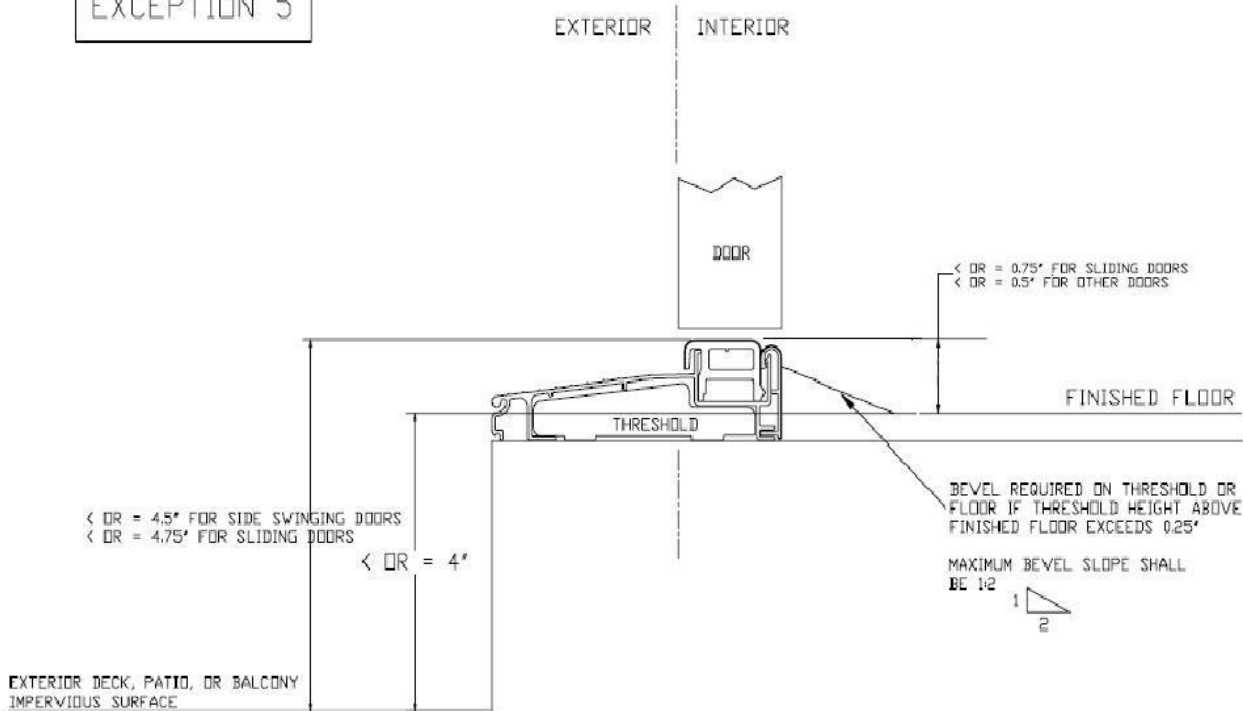

It is our hope that this proposal will address the concerns of ADA advocates who might be opposed to the current exception to Section 1008.1.7, permit our industry to provide thresholds that have a higher potential to resist water infiltration, even under extreme weather conditions, at least for those exterior doorways included within the scope of Exceptions 3 and 5 to Section 1008.1.5, and clarify the intent of the IBC with regards to door thresholds. We urge the committee's approval of this code change proposal.

Cost Impact: This code change proposal will not increase the cost of construction.

Public Hearing: Committee: AS AM D
 Assembly: ASF AMF D

Filename: RUTH-E2-1008.1.5

E58-09/10

1008.1.7 (IFC [B] 1008.1.7); IRC R311.3.1

Proponent: Julie Ruth, JRuth Code Consulting, representing AAMA

THIS IS A 2 PART CODE CHANGE. PART I WILL BE HEARD BY THE MEANS OF EGRESS COMMITTEE. PART II WILL BE HEARD BY THE IRC BUILDING/ENERGY COMMITTEE. SEE THE TENTATIVE HEARING ORDERS FOR THESE COMMITTEES.

PART I – IBC MEANS OF EGRESS

Revise as follows:

1008.1.7 (IFC [B] 1008.1.7) Thresholds. Thresholds at doorways shall not exceed 3/4 inch (19.1 mm) in height above the finished floor or landing for sliding doors serving dwelling units or 1/2 inch (12.7 mm) above the finished floor or landing for other doors. Raised thresholds and floor level changes greater than 1/4 inch (6.4mm) at doorways shall be beveled with a slope not greater than one unit vertical in two units horizontal (50-percent slope).

Exception: The threshold height shall be limited to 73/4 inches (197 mm) where the occupancy is Group R-2 or R-3; the door is an exterior door that is not a component of the required means of egress; the door, other than an exterior storm or screen door, does not swing over the landing or step; and the doorway is not on an accessible route as required by Chapter 11 and is not part of an Accessible unit, Type A unit or Type B unit.

PART II – IRC BUILDING/ENERGY

Revise as follows:

R311.3.1 Floor elevations at the required egress door. Landings or finished floors at the required egress door shall not be more than 1.5 inches (38 mm) lower than the top of the threshold.

Exception: The ~~exterior~~ landing or floor on the exterior side shall not be more than 7 3/4 inches (197 mm) below the top of the threshold provided the door does not swing over the landing or floor.

When exterior landings or floors serving the required egress door are not at grade, they shall be provided with access to grade by means of a ramp in accordance with Section R311.8 or a stairway in accordance with Section R311.7.

Reason:

PART I – This proposal clarifies that threshold height is to be measured to the finished floor or landing, and not the top of the subfloor or other surface.

PART II - This proposal clarifies that threshold height is to be measured to the finished floor or landing, and not the top of the subfloor or other surface, and that it is the exterior floor or landing that is permitted to be up to 7 ¾ inches below the top of the threshold, when other criteria are met. As the code currently reads, it could be misconstrued to mean the exterior landing or ANY floor shall not be more than 7 ¾ inches below the top of the threshold. This is not the intent of this exception. The proposal seeks to clarify that.

Cost Impact: The code change will not increase the cost of construction.

PART I – IBC MEANS OF EGRESS

Public Hearing:	Committee:	AS	AM	D
	Assembly:	ASF	AMF	DF

PART II – IRC BUILDING/ENERGY

Public Hearing:	Committee:	AS	AM	D
	Assembly:	ASF	AMF	DF

ICCFILENAME: RUTH-E1-1008.1.7.DOC

E59–09/10

1008.1.7 (IFC [B] 1008.1.7)

Proponent: Jeff Lowinski, representing the Window and Door Manufacturers Association (WDMA)

Revise as follows:

1008.1.7 (IFC [B] 1008.1.7) Thresholds. Thresholds at doorways shall not exceed 3/4 inch (19.1 mm) in height for sliding doors serving dwelling units or 1/2 inch (12.7 mm) for other doors. Raised thresholds and floor level changes greater than 1/4 inch (6.4 mm) at doorways shall be beveled with a slope not greater than one unit vertical in two units horizontal (50-percent slope).

~~**Exception:** The threshold height shall be limited to 7 3/4 inches (197 mm) where the occupancy is Group R-2 or R-3; the door is an exterior door that is not a component of the required means of egress; the door, other than an exterior storm or screen door, does not swing over the landing or step; and the doorway is not on an accessible route as required by Chapter 11 and is not part of an Accessible unit, Type A unit or Type B unit.~~

Exception: In occupancy Group R-2 or R-3, threshold heights for sliding and side-hinged exterior doors shall be permitted to be up to 7-3/4 inches (197mm) in height if all of the following apply:

1. The door is not part of the required means of egress.
2. The door is not part of an accessible route as required by Chapter 11.
3. The door is not part of an Accessible unit, Type A unit or Type B unit.

Reason: This proposal clarifies the exception in this section of the code for ease of understanding and enforcement. This revision is intended to essentially an editorial reformatting of the technical requirements of the code. WDMA members have received numerous questions from code officials and project owners regarding this section of the IBC. This proposal removes the reference to exterior storm and screen doors because this is addressed in 1008.1.5, Exception 1.2.

Cost Impact: The code change proposal will not increase the cost of construction.

Public Hearing: Committee:	AS	AM	D
Assembly:	ASF	AMF	DF

ICCFILENAME:Woestman-E1-1008.1.7

E60–09/10

1008.1.9.3 (IFC [B] 1008.1.9.3); IPMC 304.18.1; IRC R311.2, R311.2.1 (New)

Proponent: John Morgan, City of Frontenac, Missouri, representing Missouri Association of Building Officials and Inspectors

THIS IS A 3 PART CODE CHANGE. PARTS I AND II WILL BE HEARD BY THE MEANS OF EGRESS COMMITTEE. PART III WILL BE HEARD BY THE IRC BUILDING/ENERGY COMMITTEE. SEE THE TENTATIVE HEARING ORDERS FOR THESE COMMITTEES.

PART I – IBC MEANS OF EGRESS

Revise as follows:

1008.1.9.3 (IFC [B] 1008.1.9.3) Locks and latches. Locks and latches shall be permitted to prevent operation of doors where any of the following exists:

1. Places of detention or restraint.
2. In buildings in occupancy Group A having an occupant load of 300 or less, Groups B, F, M and S, and in places of religious worship, the main exterior door or doors are permitted to be equipped with key-operated locking devices from the egress side provided:
 - 2.1. The locking device is readily distinguishable as locked;
 - 2.2. A readily visible durable sign is posted on the egress side on or adjacent to the door stating: THIS DOOR TO REMAIN UNLOCKED WHEN BUILDING IS OCCUPIED. The sign shall be in letters 1 inch (25 mm) high on a contrasting background; and
 - 2.3. The use of the key-operated locking device is revocable by the building official for due cause.
3. Where egress doors are used in pairs, approved automatic flush bolts shall be permitted to be used, provided that the door leaf having the automatic flush bolts has no doorknob or surface-mounted hardware.

4. ~~Doors from individual dwelling or sleeping units of Group R occupancies having an occupant load of 10 or less are permitted to be equipped with a night latch, dead bolt or security chain, provided such devices are openable from the inside without the use of a key or tool. All side-hinged doors providing access to individual dwelling units or sleeping units of Group R occupancies shall be equipped with a deadbolt lock designed to be readily openable from the side which egress is to be made without the need for keys, special knowledge or effort and shall have a lock throw of not less than 1 inch (25mm).~~
Exception: Dead bolts shall not be required on doors leading from dwelling units to attached garages, where secured exterior garage doors are provided.
5. Fire doors after the minimum elevated temperature has disabled the unlatching mechanism in accordance with listed fire door test procedures.

PART II – IPMC

Revise as follows:

304.18.1 Doors. All side-hinged doors providing access to a dwelling unit, rooming unit or housekeeping unit that is rented, leased or let shall be equipped with a deadbolt lock designed to be readily openable from the side from which egress is to be made without the need for keys, special knowledge or effort and shall have a lock throw of not less than 1 inch. Such deadbolt locks shall be installed according to the manufacturer's specifications and maintained in good working order. For the purpose of this section, a sliding bolt shall not be considered an acceptable deadbolt lock.

Exception: Dead bolts shall not be required on doors leading from dwelling units to attached garages, where secured exterior garage doors are provided.

PART III – IRC BUILDING/ENERGY

Add new text as follows:

R311.2 Egress door. At least one egress door shall be provided for each *dwelling* unit. The egress door shall be side-hinged, and shall provide a minimum clear width of 32 inches (813 mm) when measured between the face of the door and the stop, with the door open 90 degrees (1.57 rad). The minimum clear height of the door opening shall not be less than 78 inches (1981 mm) in height measured from the top of the threshold to the bottom of the stop. Other doors shall not be required to comply with these minimum dimensions. ~~Egress doors shall be readily openable from inside the *dwelling* without the use of a key or special knowledge or effort.~~

R311.2.1 Door locks and latches. All side-hinged doors providing access to a dwelling unit shall be equipped with a deadbolt lock designed to be readily openable from the side which egress is to be made without the need for keys, special knowledge or effort and shall have a lock throw of not less than 1 inch (25mm).

Exception: Dead bolts shall not be required on doors leading from dwelling units to attached garages, where secured exterior garage doors are provided.

Reason:

Part I & III-The purpose of this change is to coordinate the requirements for deadbolts between the IPMC, IBC and IRC. Currently section 304.18.1 of the IPMC requires deadbolts to be installed on doors providing access to a dwelling unit, rooming unit, or housekeeping unit that is rented, leased or let. It is not reasonable to require a minimum level of security to a renter, but not provide that same security to a person who owns the property.

Furthermore, at the time of construction it is not reasonable to know the intentions of the owner to possibly lease, rent or let the unit. This can lead to additional steps to obtain compliance when it is learned that a unit is to be a rental. Originally in the IPMC it states all doors providing access, and we are proposing a change to the IPMC to address the need to allow certain style doors such as glass sliding doors and doors leading to secured garages to be exempt from this requirement as we are recommending in this change. The IPMC does require all doors, windows and hatchways to have security devices, therefore sliding doors would have to have some type of locking device.

Part II- The purpose of the change is to coordinate the requirements for deadbolts between the IPMC, IRC and IBC. The current language hinders the coordination of the codes through the installation of deadbolts on differing types of doors. This section will clarify on which doors deadbolts are required and where they are exempt, (i.e. sliding glass doors, and doors between a residence and an attached garage, which are required by 304.18 to have some type of security device).

Cost Impact: Part I & III-The code change proposal will have minimal increase to cost of construction.

Cost Impact: Part II- The code change proposal will not increase the cost of construction.

PART I – IBC MEANS OF EGRESS

Public Hearing:	Committee:	AS	AM	D
	Assembly:	ASF	AMF	DF

PART II – IPMC

Public Hearing: Committee: AS AM D
Assembly: ASF AMF DF

PART III – IRC BUILDING/ENERGY

Public Hearing: Committee: AS AM D
Assembly: ASF AMF DF

ICCFILENAME:Morgan-E1-1008.1.9.3

E61–09/10

1008.1.9.3 (IFC [B] 1008.1.9.3)

Proponent: Jim McClintic, Sandy City, representing the Utah Chapter

Revise as follows:

1008.1.9.3 (IEBC [B] 1008.1.9.3) Locks and latches. Locks and latches shall be permitted to prevent operation of doors where any of the following exists:

1. Places of detention or restraint.
2. In buildings in occupancy Group A having an occupant load of 300 or less, Groups B, F, M and S, and in places of religious worship, the main exterior door or doors are permitted to be equipped with key-operated locking devices from the egress side provided:
 - 2.1. The locking device is readily distinguishable as locked;
 - 2.2. A readily visible durable sign is posted on the egress side on or adjacent to the door stating: THIS DOOR TO REMAIN UNLOCKED WHEN BUILDING IS OCCUPIED. The sign shall be in letters 1 inch (25 mm) high on a contrasting background; and
 - 2.3. The use of the key-operated locking device is revocable by the building official for due cause.
3. Where egress doors are used in pairs, approved automatic flush bolts shall be permitted to be used, provided that the door leaf having the automatic flush bolts has no doorknob or surface-mounted hardware.
4. Doors from individual dwelling or sleeping units of Group R occupancies having an occupant load of 10 or less are permitted to be equipped with a night latch, dead bolt or security chain, provided such devices are openable from the inside without the use of a key or tool and complying with the height requirements outlined in Section 1008.1.9.2.
5. Fire doors after the minimum elevated temperature has disabled the unlatching mechanism in accordance with listed fire door test procedures.

Reason: This additional language will clarify hardware height requirements in these locations and help eliminate the confusion when this section of the code is being enforced.

Cost Impact: The code change proposal will not increase the cost of construction.

Public Hearing: Committee: AS AM D
Assembly: ASF AMF DF

ICCFILENAME:Mcclintic-E1-1008.1.9.3

E62–09/10

1008.1.9.3 (IFC [B] 1008.1.9.3)

Proponent: Lee Kranz representing Washington Association of Building Officials (WABO), Technical Code Development Committee

Revise as follows:

1008.1.9.3 (IFC [B] 1008.1.9.3) Locks and latches. Locks and latches shall be permitted to prevent operation of doors where any of the following exists:

1. Places of detention or restraint.
2. In buildings in occupancy Group A having an occupant load of 300 or less, Groups B, F, M and S, and in places of religious worship, the main exterior door or doors are permitted to be equipped with key-operated locking devices from the egress side provided:
 - 2.1. The locking device is readily distinguishable as locked;
 - 2.2. A readily visible durable sign is posted on the egress side on or adjacent to the door stating: THIS DOOR TO REMAIN UNLOCKED WHEN BUILDING IS OCCUPIED. The sign shall be in letters 1 inch (25 mm) high on a contrasting background; and
 - 2.3. The use of the key-operated locking device is revocable by the building official for due cause.
3. Where egress doors are used in pairs, approved automatic flush bolts shall be permitted to be used, provided that the door leaf having the automatic flush bolts has no doorknob or surface-mounted hardware.
4. Doors from individual dwelling or sleeping units of Group R occupancies having an occupant load of 10 or less are permitted to be equipped with a night latch, dead bolt or security chain, provided such devices are openable from the inside without the use of a key or tool.
5. Fire doors after the minimum elevated temperature has disabled the unlatching mechanism in accordance with listed fire door test procedures.
6. Doors serving outdoor areas specified in Section 1004.8 having an occupant load of 300 or less are permitted to be equipped with key-operated locking devices from the egress side provided:
 - 6.1. The locking device is readily distinguishable as locked;
 - 6.2. A readily visible durable sign is posted on the egress side on or adjacent to the door stating: THIS DOOR TO REMAIN UNLOCKED WHEN THE BUILDING IS OCCUPIED. The sign shall be in letters 1 inch (25 mm) high on a contrasting background;
 - 6.3. A two-way communication system complying with Sections 1007.8.1 and 1007.8.2 shall be provided on the egress side.
 - 6.4. The use of the key-operated locking device is revocable by the building official.

Reason: Egress from confined outdoor areas, as required by Section 1004.8, is necessary. Unfortunately, many building owners are reluctant to leave required egress doors from these areas unlocked for security reasons, which places the public at risk. Fire Code officials, who conduct maintenance inspections, and building owners are at odds on this issue. It makes sense to recognize that this conflict exists and place safeguards in the code to eliminate the conflict. The two-way communication system will allow an occupant to call for help if the egress is accidentally locked while the outdoor area is occupied. This new text is similar to exception #2 of Section 1008.1.9.3 as it relates to an allowance to lock egress doors under certain conditions.

Cost Impact: This code change proposal will increase the cost of construction.

Public Hearing: Committee:	AS	AM	D
Assembly:	ASF	AMF	DF

ICCFILENAME: KRANZ-E2-1008.1.9.3.DOC

E63–09/10

1008.1.9.3 (IFC [B] 1008.1.9.3)

Proponent: Tom Lariviere, Chairman, representing Joint Fire Service Review Committee

Revise as follows:

1008.1.9.3 (IFC [B] 1008.1.9.3) Locks and latches. Approved locks and latches shall be permitted to prevent operation of doors where any of the following exists:

1. Places of detention or restraint.
2. In buildings in occupancy Group A having an occupant load of 300 or less, Groups B, F, M and S, and in places of religious worship, the main exterior door or doors are permitted to be equipped with key-operated locking devices from the egress side provided:
 - 2.1 The locking device is readily distinguishable as locked;
 - 2.2 A readily visible durable sign is posted on the egress side on or adjacent to the door stating: THIS DOOR TO REMAIN UNLOCKED WHEN BUILDING IS OCCUPIED. The sign shall be in letters 1 inch (25 mm) high on a contrasting background; and
 - 2.3 The use of the key-operated locking device is revocable by the building official for due cause.
3. Where egress doors are used in pairs, approved automatic flush bolts shall be permitted to be used, provided that the door leaf having the automatic flush bolts has no doorknob or surface-mounted hardware.

4. Doors from individual dwelling or sleeping units of Group R occupancies having an occupant load of 10 or less are permitted to be equipped with a night latch, dead bolt or security chain, provided such devices are openable from the inside without the use of a key or tool.
5. Fire doors after the minimum elevated temperature has disabled the unlatching mechanism in accordance with listed fire door test procedures.
6. In Group I-2 occupancies housing clients where the means of egress needs to be secured for the safety of the clients provided all the following requirements are met:
 - 6.1 The facility is equipped throughout with an automatic sprinkler system in accordance with Section 903.3.1.1,
 - 6.2 The doors unlock upon actuation of the automatic sprinkler system,
 - 6.3 The doors unlock upon activation of the automatic smoke detection system,
 - 6.4 The doors unlock upon loss of power controlling the lock or lock mechanism,
 - 6.5 The door locks shall have the capability of being unlocked by a signal from an approved location,
 - 6.6 Emergency lighting is provided at the door, and
 - 6.7 The facility is constantly staffed.

Reason: The new language addresses the problem faced by providers of patients suffering from Alzheimer's or Dementia wandering out of facilities and endangering their persons. Cognitive impairments caused by these diseases and other forms of dementia, render the residents of this type of facility unable to make the most appropriate decisions for their safety and welfare. This proposal would allow for door locking arrangements without delayed egress locks that are currently approved in health care type occupancies.

These patients can be very quick and mobile. The delayed egress lock poses a very challenging situation for staff when providing care for these patients who seek wandering or "exit seeking" associated with their disease.

Cost Impact: The code change proposal will not increase the cost of construction.

Analysis: A concern would be how this proposal will coordinate with Section 1008.1.9.6 Special locking arrangements in Group I-2.

Public Hearing: Committee: AS AM D
 Assembly: ASF AMF DF

ICCFILENAME:Lariviere-E1-1008.1.9.3

E64-09/10

1008.1.9.4 (IFC [B] 1008.1.9.4)

Proponent: Gene Boecker, AIA, Code Consultants, Inc., representing Code Consultants, Inc.

Revise as follows:

1008.1.9.4 (IFC [B] 1008.1.9.4) Bolt locks. Manually operated flush bolts or surface bolts are not permitted.

Exceptions:

1. On doors not required for egress in individual dwelling units or sleeping units.
2. Where a pair of doors serves a storage or equipment room, manually operated edge- or surface-mounted bolts are permitted on the inactive leaf.
3. Where a pair of doors serves an *occupant load* of less than 50 persons in a Group B, F or S occupancy, manually operated edge- or surface-mounted bolts are permitted on the inactive leaf. The inactive leaf shall contain no doorknobs, panic bars or similar operating hardware.
4. Where a pair of doors serves a Group B, F or S occupancy, manually operated edge- or surface-mounted bolts are permitted on the inactive leaf provided such inactive leaf is not needed to meet egress width requirements and the building is equipped throughout with an *automatic sprinkler system* in accordance with Section 903.3.1.1. The inactive leaf shall contain no doorknobs, panic bars or similar operating hardware.
5. Where a pair of doors serves patient care rooms in Group I-2 occupancies, self-latching edge or surface-mounted bolts are permitted on the inactive leaf provided that the inactive leaf is not needed to meet egress width requirements and the inactive leaf contains no doorknobs, panic bars or similar operating hardware.
6. Where pairs of doors are installed in accordance with Section 1008.1.9.3, item 2, the inactive leaf shall be permitted to be equipped with manually operated surface or flush bolts provided the building is equipped throughout with an automatic sprinkler system in accordance with Section 903.3.1.1 and the inactive leaf is not required for means of egress width.

Reason: This recognizes one of the current practices in the construction industry. Whether we choose to admit it or not, the standard manner in which the doors are installed in compliance with item #2 for Section 1008.1.9.3 is that the active leaf has the readily distinguishable lock and sign

while the inactive leaf is simply held in place by flush (edge) bolts. It is the flush bolt that keeps the inactive leaf secure so that the active leaf can be locked when the building is not occupied.

Although it could be easy to simply recognize this condition and include it alone, the exception adds the requirement for sprinkler protection as an added measure of safety. It also differentiates this exception from exception #3 which limits the occupant load to less than 50 and does not address sprinkler protection.

Cost Impact: The code change proposal will not increase the cost of construction.

Public Hearing:	Committee:	AS	AM	D
	Assembly:	ASF	AMF	DF

ICCFILENAME:Boecker-E2-1008.1.9.4

E65-09/10

1008.1.9.8 (IFC [B] 1008.1.9.8)

Proponent: Edward A. Hite, CML, representing self

Revise as follows:

1008.1.9.8 (IFC [B] 1008.1.9.8) Electromagnetically locked egress doors. Doors in the means of egress ~~that are not otherwise required to have panic hardware~~ in buildings with an occupancy in Group A, B, E, M, R-1 or R-2 and doors to tenant spaces in Group A, B, E, M, R-1 or R-2 shall be permitted to be electromagnetically locked if equipped with listed hardware that incorporates a built-in switch and meet the requirements below:

1. The listed hardware that is affixed to the door leaf has an obvious method of operation that is readily operated under all lighting conditions.
2. The listed hardware is capable of being operated with one hand.
3. Operation of the listed hardware releases ~~to~~ the electromagnetic lock and unlocks the door immediately.
4. Loss of power to the listed hardware automatically unlocks the door.

Reason: Bars tested and listed to release electromagnetic locks include both panic bars and fire exit hardware. When power is removed from a listed electromagnetic lock, it will release in less than ½ second. Bars with switches directly release that power. The number of people going through the door has no bearing on this.

Cost Impact: The code change proposal will not increase the cost of construction.

Public Hearing:	Committee:	AS	AM	D
	Assembly:	ASF	AMF	DF

ICCFILENAME: HITE-E2-1008.1.9.8

E66-09/10

1008.1.9.10 (IFC [B] 1008.1.9.10)

Proponent: Tom Lariviere, Chairman, representing Joint Fire Service Review Committee

Revise as follows:

1008.1.9.10 (IFC [B] 1008.1.9.10) Stairway doors. Interior stairway means of egress doors shall be openable from both sides without the use of a key or special knowledge or effort.

Exceptions:

1. Stairway discharge doors shall be openable from the egress side and shall only be locked from the opposite side.
2. This section shall not apply to doors arranged in accordance with Section 403.5.3.
3. ~~In stairways serving not more than four stories, Stairway doors are permitted to be locked from the stairway side opposite the egress side, provided they are openable from the egress side and when the stairway serves no more than four stories and the doors are capable of being unlocked simultaneously without unlatching upon a signal from the fire command center, if present, or a signal by emergency personnel from a single location inside the main entrance to the building.~~

4. Stairway doors are permitted to be locked from the stairway side when the stairways serves no more than two stories and the stairway discharge door leads directly to the exit discharge and a key box is provided in accordance with Section 506 of the International Fire Code.

Reason: Many buildings are concerned with security and reentry into the building from the stairways. As a result, building owners and managers desire to lock the stairwell doors to prohibit entry onto the floor from the stairwell. This practice of locking the stairwell doors increases the building security.

This proposal will provide an additional exception for buildings not more than two stories in height. This new exception will allow for the prohibition of reentry from the stairwell as long as a key box is provided for fire department use. The fire department could access the key box and unlock the stairwell doors for fire use.

The current requirements allow for the locking of these doors, but only if an electric override is provided within the building for fire department use. The current requirement is overly restrictive for stairways serving only two stories, and this exception will provide another option for building owners and managers.

Item 4 is added to provide the allowance for doors to be locked when the building serves no more than 2 stories. Item 3 is revised without changing the intent. This revision is to simplify the wording and clarify the section. This wording is similar to the current wording in Section 403.5.3.

Cost Impact: This code change proposal will decrease the cost of construction.

Public Hearing: Committee:	AS	AM	D
Assembly:	ASF	AMF	DF

ICCFILENAME:Lariviere-E3-1008.1.9.10

E67-09/10

1009.1 (IFC [B] 1009.1)

Proponent: Gregory R. Keith, Professional heuristic Development, representing The Boeing Company

Revise as follows:

1009.1 (IFC [B] 1009.1) General. Stairways serving occupied portions of a building shall comply with the requirements of this section.

~~1009.1~~ **1009.2 (IFC [B] ~~1009.1~~ 1009.2) Stairway Width.** The width of stairways shall be determined as specified in Section 1005.1, but such width shall not be less than 44 inches (1118 mm). See Section 1007.3 for accessible means of egress stairways.

Exceptions:

1. Stairways serving an occupant load of less than 50 shall have a width of not less than 36 inches (914 mm).
2. Spiral stairways as provided for in Section 1009.9.
3. Aisle stairs complying with Section 1028.
4. Where an incline platform lift or stairway chairlift is installed on stairways serving occupancies in Group R-3, or within dwelling units in occupancies in Group R-2, a clear passage width not less than 20 inches (508 mm) shall be provided. If the seat and platform can be folded when not in use, the distance shall be measured from the folded position.

(Renumber subsequent sections)

Reason: Presently, Section 1009 has no general charging provisions. It is essential that all means of egress components have legal charging statements so as to establish the applicability of given prescriptive technical requirements. This is especially true with stairways. Often, there are stairs or stairways in a building in excess of those minimally required to support a given means of egress design. This proposal establishes that the applicable technical provisions of Section 1009 apply to all stairways serving occupied portions of the building, regardless of whether or not they are a required means of egress component. Approval of this proposal will increase consistency in the application of very important stairway provisions.

Cost Impact: The code change proposal will not increase the cost of construction.

Public Hearing: Committee:	AS	AM	D
Assembly:	ASF	AMF	DF

ICCFILENAME:Keith-E7-1009.1

E68–09/10

1009.1 (IFC [B] 1009.1)

Proponent: Catherine Heeb, representing City of Portland Bureau of Development Services

Revise as follows:

1009.1 (IFC [B] 1009.1) Stairway width. The width of stairways shall be determined as specified in Section 1005.1, but such width shall not be less than 44 inches (1118 mm). See Section 1007.3 for accessible means of egress stairways.

Exceptions:

1. Stairways serving an occupant load of less than 50 shall have a width of not less than 36 inches (914 mm).
2. Spiral stairways as provided for in Section 1009.9.
3. Aisle stairs complying with Section 1028.
4. Where an incline platform lift or stairway chairlift is installed on stairways serving occupancies in Group R-3, or within dwelling units in occupancies in Group R-2, a clear passage width not less than 20 inches (508 mm) shall be provided. If the seat and platform can be folded when not in use, the distance shall be measured from the folded position.
5. Stairways in Group E serving an occupant load of 100 or more shall have a width of not less than 60 inches (1525 mm).

Reason: The code currently and historically has required 6' corridors in group E occupancies where the occupant load is over 100 (2009 IBC 1018.2, exception 4). The prior Uniform Building Code required a 5' minimum width on the stair (1997 UBC, section 1007.3.5) as well.

As written, a 44" stair in an E occupancy could accommodate 146 occupants, and a 5' stair would not be needed until it served 200 occupants. The code acknowledges that stairs require greater egress width than other means of egress components by requiring 0.3" of width per occupant stair as compared to 0.2" for other portions of the means of egress. Given the population served, the presence of other distractions, and the possibility of staff occupying landings to guide students during an evacuation, the 5' stair width is needed to alleviate congestion and improve egress on staircases in large E occupancies.

Cost Impact: The code change proposal will increase the cost of construction.

Public Hearing: Committee:	AS	AM	D
Assembly:	ASF	AMF	DF

ICCFILENAME:Heeb-E1-1009.1

E69–09/10

1009.1, 1009.12, 1013.2 (IFC [B] 1009.1, 1009.12, 1013.2)

Proponent: John Jensen, representing Chevron Products Company

Revise as follows:

1009.1 (IFC [B] 1009.1) Stairway width. The width of stairways shall be determined as specified in Section 1005.1, but such width shall not be less than 44 inches (1118 mm). See Section 1007.3 for accessible means of egress stairways.

Exceptions:

1. Stairways serving an occupant load of less than 50 shall have a width of not less than 36 inches (914 mm).
2. Spiral stairways as provided for in Section 1009.9.
3. Aisle stairs complying with Section 1028.
4. Where an incline platform lift or stairway chairlift is installed on stairways serving occupancies in Group R-3, or within dwelling units in occupancies in Group R-2, a clear passage width not less than 20 inches (508 mm) shall be provided. If the seat and platform can be folded when not in use, the distance shall be measured from the folded position.
5. Stairways serving industrial applications and construction site trailers shall have a width of not less than 30 inches.

1009.12 (IFC [B] 1009.12) Handrails. Stairways shall have handrails on each side and shall comply with Section 1012. Where glass is used to provide the handrail, the handrail shall also comply with Section 2407.

Exceptions:

1. Handrails for aisle stairs are not required where permitted by Section 1028.13.
2. Stairways within dwelling units, spiral stairways and aisle stairs serving seating only on one side are permitted to have a handrail on one side only.
3. Decks, patios and walkways that have a single change in elevation where the landing depth on each side of the change of elevation is greater than what is required for a landing do not require handrails.
4. In Group R-3 occupancies, a change in elevation consisting of a single riser at an entrance or egress door does not require handrails.
5. Changes in room elevations of three or fewer risers within dwelling units and sleeping units in Group R-2 and R-3 do not require handrails.
6. Stairways serving industrial applications and construction site trailers are permitted to have handrails on only the open side of the stairway.

1013.2 (IFC [B] 1013.2) Height. Required guards shall be not less than 42 inches (1067 mm) high, measured vertically above the adjacent walking surfaces, adjacent fixed seating or the line connecting the leading edges of the treads.

Exceptions:

1. For occupancies in Group R-3, and within individual dwelling units in occupancies in Group R-2, guards on the open sides of stairs shall have a height not less than 34 inches (864 mm) measured vertically from a line connecting the leading edges of the treads.
2. For occupancies in Group R-3, and within individual dwelling units in occupancies in Group R-2, where the top of the guard also serves as a handrail on the open sides of stairs, the top of the guard shall not be less than 34 inches (864 mm) and not more than 38 inches (965 mm) measured vertically from a line connecting the leading edges of the treads.
3. For stairways serving industrial applications and construction site trailers, where the top of guard also serves as a handrail, the top of the guard shall be permitted be at the height specified for handrails in Section 1012.2.
34. The height in assembly seating areas shall be in accordance with Section 1028.14.
45. Along alternating tread devices and ship ladders, guards whose top rail also serves as a handrail, shall have height not less than 30 inches (762 mm) and not more than 34 inches (864 mm), measured vertically from the leading edge of the device tread nosing.

Reason: The purpose of this proposal is to provide allowances for stairs serving industrial applications and construction site trailers where access is limited. Section 1009.1 - A stairway with a minimum width of 30 inches meets the requirements for industrial stair width per Cal OSHA (Section 3234(d)). Section 1009.12 - A stairway with a handrail on only the open side of exposed stairways meets the requirements for industrial stairs per Cal OSHA (Section 3234 (g)). Section 1013.2 - A guardrail on stairways with a vertical height that of handrails meets the requirements for industrial stairs per Cal OSHA (Section 3214 (b), 3234 (g)(3)).

Cost Impact: The code change proposal will not increase the cost of construction.

Public Hearing: Committee:	AS	AM	D
Assembly:	ASF	AMF	DF

ICCFILENAME: JENSEN-E1-1013.2

E70-09/10

1009.4.1 (IFC [B] 1009.4.1); IRC R311.7.4

Proponent: Tim Pate, City and County of Broomfield, representing the Colorado Chapter ICC Code Change Committee

THIS IS A 2 PART CODE CHANGE. PART I WILL BE HEARD BY THE IBC MEANS OF EGRESS. PART II WILL BE HEARD BY THE IRC BUILDING/ENERGY COMMITTEE. SEE THE TENTATIVE HEARING ORDERS FOR THESE COMMITTEES.

PART I – IBC MEANS OF EGRESS

Revise as follows:

1009.4.1 (IFC [B] 1009.4.1) Dimension Reference Surfaces. For the purpose of this section all dimensions are exclusive of ~~carpets,~~ rugs, or runners.

PART II – IRC BUILDING/ENERGY

Revise as follows:

R311.7.4 Stair treads and risers. Stair treads and risers shall meet the requirements of this section. For the purposes of this section all dimensions and dimensioned surfaces shall be exclusive of ~~carpets,~~ rugs or runners.

Reason: This code change will delete the word “carpets” since it does not make any sense to require inspectors to do inspections and sign off on stairs before all of the floor coverings are installed. Building departments will always require all floor finishes to be installed at time of final inspection to verify handicap accessibility requirements and flame/smoke spread requirements – especially on stairs. We also see some stairs that have a mix of carpet and hard surfaces (wood or tile) and the current language would require the stairs to have these hard surfaces but not carpet which would probably not get the treads and risers to meet the plus or minus $\frac{3}{8}$ ” rule – especially if using $\frac{3}{4}$ ” wood at top and/or bottom landings. We typically do quick check of stairs at time of roughs so as to see if they might be way off but a lot times all of the stairs are not even in place at time of roughs so that would necessitate contractor having to call in for special inspection of stairs after hard surfaces are installed but before carpet is installed.

I understand the original proponents’ reason statement for bringing in this new section feel that this will result in even more problems when doing inspections. I firmly believe that all of the floor finishes need to be installed and checked at time of complete final inspection and this will result in uniformity in inspection process.

Cost Impact: The code change proposal will not increase the cost of construction.

PART I – IBC MEANS OF EGRESS

Public Hearing:	Committee:	AS	AM	D
	Assembly:	ASF	AMF	DF

PART II – IRC BUILDING/ENERGY

Public Hearing:	Committee:	AS	AM	D
	Assembly:	ASF	AMF	DF

ICCFILENAME: PATE-E1-1009.4

E71-09/10

1009.4.1 (IFC [B] 1009.4.1); IRC R311.7.4

Proponent: Dave Frable, U.S. General Services Administration, representing the U.S. General Services Administration

THIS IS A 2 PART CODE CHANGE. PART I WILL BE HEARD BY THE IBC MEANS OF EGRESS. PART II WILL BE HEARD BY THE IRC BUILDING/ENERGY COMMITTEE. SEE THE TENTATIVE HEARING ORDERS FOR THESE COMMITTEES.

PART I – IBC MEANS OF EGRESS

Revise as follows:

1009.4.1 (IFC [B] 1009.4.1) Dimension reference surfaces. For the purpose of this section, all dimensions are ~~exclusive~~ inclusive of carpets, rugs or runners.

PART II – IRC BUILDING/ENERGY

Revise as follows:

R311.7.4 Stair treads and risers. Stair treads and risers shall meet the requirements of this section. For the purposes of this section all dimensions and dimensioned surfaces shall be ~~exclusive~~ inclusive of carpets, rugs or runners.

Reason: The intent of this code change is to ensure the method for measuring riser height and tread depth includes all floor coverings including carpets, rugs, or runners. Stairs that are covered with resilient floor coverings might need additional tread depth beyond the minimum specified in the IBC. Any horizontal projection of resilient covering materials beyond the tread nosing and riser, such as carpet and underlayment, can interfere with users' feet and thereby reduce usable tread depth. At the tread nosing, such resilient covering materials might not be capable of providing stable support for users' feet. Generally, effective tread depth is reduced by the uncompressed thickness of such resilient coverings and might be further reduced over time if coverings are not well secured and consequently might move forward at the nosings.

Cost Impact: This code change will not increase the cost of construction.

PART I – IBC MEANS OF EGRESS

Public Hearing:	Committee:	AS	AM	D
	Assembly:	ASF	AMF	DF

PART II – IRC BUILDING/ENERGY

Public Hearing:	Committee:	AS	AM	D
	Assembly:	ASF	AMF	DF

ICCFILENAME:Frable-E1-1009.4

E72-09/10

1009.4.1 (IFC [B] 1009.4.1); IRC R311.7.4

Proponent: Jake Pauls, representing self

THIS IS A 2 PART CODE CHANGE. PART I WILL BE HEARD BY THE IBC MEANS OF EGRESS. PART II WILL BE HEARD BY THE IRC BUILDING/ENERGY COMMITTEE. SEE THE TENTATIVE HEARING ORDERS FOR THESE COMMITTEES.

PART I – IBC MEANS OF EGRESS

Revise as follows:

1009.4.1. (IFC [B] 1009.4.1) Dimension reference surfaces ~~For the purpose of this section, all dimensions are exclusive of carpets, rugs or runners.~~ Dimensions of rise and tread depth shall be permitted to be taken without carpet, rug runner or pad covering in place provided that all surfaces that are intended to be so covered are consistently measured without such covering in place. Subsequently applied covering, prior to final inspection, shall be securely

fixed in place and be consistent in overall thickness on all surfaces measured for rise and tread depth so that the uniformity limits stipulated in Section 1009.4.4 are maintained. Nosing profiles, in accordance with Section 1009.4.5, shall be limited to those that result, at the time of final inspection, in no more than a 9/16 inch loss of horizontal surface, due to nosing rounding or beveling of the exposed surface of any carpet, rug or runner installed over the treads.

Exception: Up to 1 inch of loss of horizontal surface at the nosing is permitted at the exposed surface of any carpet, rug or runner in place at the time of final inspection provided that the minimum tread depth stipulated in Section 1009.4.2 is increased by the amount by which such loss of horizontal surface exceeds 9/16 inch.

PART II – IRC BUILDING/ENERGY

Revise as follows:

R311.7.4 Stair treads and risers. Stair treads and risers shall meet the requirements of this section. ~~For the purposes of this section all dimensions and dimensioned surfaces shall be exclusive of carpets, rugs or runners. Dimensions of rise and tread depth shall be permitted to be taken without carpet, rug runner or pad covering in place provided that all surfaces that are intended to be so covered are consistently measured without such covering in place. Subsequently applied covering, prior to final inspection, shall be securely fixed in place and be consistent in overall thickness on all surfaces measured for rise and tread depth so that the uniformity limits stipulated in Sections R311.7.4.1 and R311.7.4.2 are maintained. Nosing profiles, in accordance with Section R311.7.4.3, shall be limited to those that result, at the time of final inspection, in no more than a 9/16 inch loss of horizontal surface, due to nosing rounding or beveling of the exposed surface of any carpet, rug or runner installed over the treads.~~

Exception: Up to 1 inch of loss of horizontal surface at the nosing is permitted at the exposed surface of any carpet, rug or runner in place at the time of final inspection provided that the minimum tread depth stipulated in Section R311.7.4.2 is increased by the amount by which such loss of horizontal surface exceeds 9/16 inch.

Reason: All my proposals deal with the urgent need to address the recent rapid growth in home stair-related injuries reported in national estimates of the U.S. Consumer Product Safety Commission, CPSC, in its National Electronic Injury Surveillance System (NEISS) and the long-term trend for much greater number of injuries related to home stairs compared to stairs in other settings. This is shown in Figure 1, the same figure used in my proposal on R311.7.4.2 but reproduced here as well because other aspects of the figure are relevant here.

Figure 1 shows two trends with home stairs. One is the long-term (one-third century) trend of home stair related injuries in the CPSC NEISS national estimates (of hospital emergency department-treated injuries) exceeding those in all other settings by about a factor of five. The recent increase to this ratio—growing in the last several years to a factor of about eight—is discussed in relation to my proposal on R311.7.4.2. The long-term trend is shown on Figure 1 with the broken line, with the three simplified straight-trend sections covering the period from about 1975 through 2007. The short-term trend, an average annual growth rate of the national estimate of nearly 5 percent—or about five times the annual rate of US population growth—is shown by the longest vertical bars, for home stair-related injuries in the period 1998 to 2007.

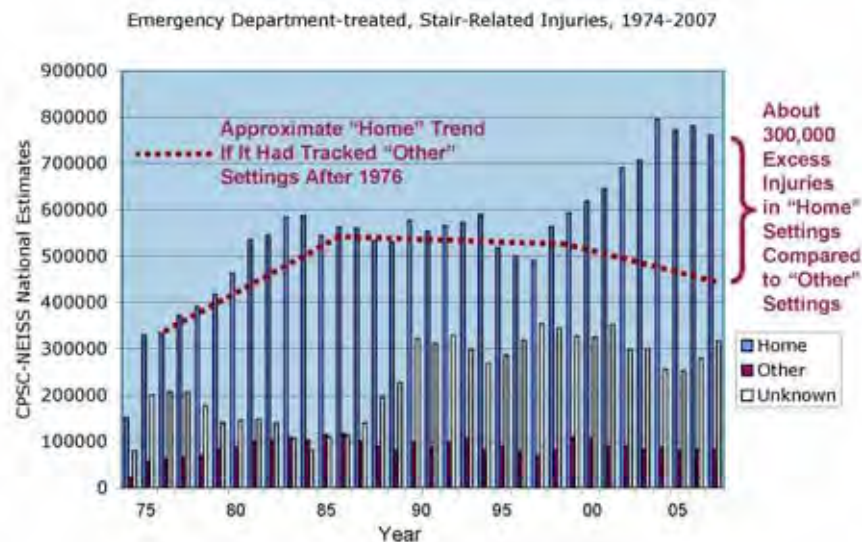

Figure 1. Growth of Home Stair-related Injuries in USA in Recent Years.

Among the reasons we have the long-term over-representation of home stair-related injuries is the significantly different code rules and practices on maximum rise, minimum tread depth, control of nosing geometry, and control of carpet and other resilient tread coverings. These differences have been most enshrined in the International Residential Code. Now with the annual societal costs of stair-related injuries in the range of \$100 billion per year in the USA (with the medical treatment cost component alone around \$10 billion per year or just over \$1 million per hour), relative to stair construction costs being only a small fraction of this, it is time for ICC members in particular to understand fully the individual, family and societal costs of all aspects of the double, lower standard for home stairways in the I-codes. After all, ICC members voted strongly in favor of home sprinkler

protection which costs far more than the various home stairway improvements in my proposals and even if sprinklers prevented all of the current fire-related injuries, the societal public health benefit would still pale in comparison with what could be achieved at lower cost with improvements to stairways. The ratio of stair-injuries to structural fire-related injuries is about 50 to one.

Furthermore, for every fall-associated use of a stair there are many that have benefits that must be considered in any benefit-cost evaluation of stairway design and construction improvements. This matter of benefits and costs is further addressed in my accompanying proposal on changes to the minimum tread depth and maximum rise height criteria where it is shown that normal (non-fall) uses of stairs are the largest benefit of providing stairs in the first place. (Sprinklers by contrast have no benefit other than controlling fire, a very, very rare event compared with the number of times daily that people use stairs in their homes for example. Each one of those stair uses has a benefit or value that must be considered in benefit-cost analyses.)

Thus, in relation to this proposal, the intent is to make sure that rise and tread depth criteria required by this code actually make meaningful differences in the usability and safety of the stairways as they are actually used, as opposed to the stairways inspected at various stages of dwelling construction before the dwelling is turned over to its occupants.

Furthermore, in keeping with stairway safety research results, the effort here is to make sure that the effective tread depth dimensions, not including the portion lost at the front of the tread due to beveling and rounding of the nosing, are meaningful in relation to the research that led to the tread depth criteria in the first place. For example, the latest published research specifically on home stair step geometry cleared showed that the tread depth dimension (called the “going” dimension in the UK and some other parts of the world)—*measured nosing face to nosing face*—was more important than was the rise dimension. The results of this study, as reported by Wright and Roys of the UK Building Research Establishment (an organization comparable to the sum of NIST and the NAHB Research Center in relation to building technology) are shown in Figure 2. Figure 2 has been augmented for some of my presentations and, indeed, is one of hundreds of PowerPoint slides in presentations given internationally over the last year or so.

Slide based on Figure 4 in paper by Wright and Roys, 2008

ACCIDENTS ON ENGLISH DWELLING STAIRS ARE DIRECTLY RELATED TO GOING SIZE

Canadian & US Dwelling Code Requirements

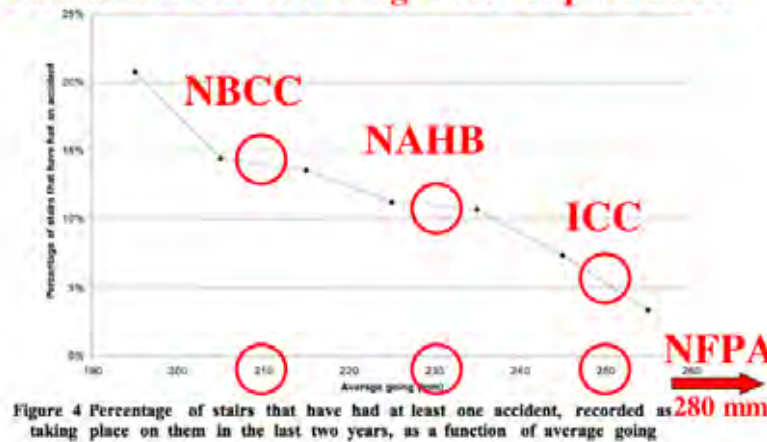

Figure 2. Role of Stair Tread Depth (“Going” in UK) in Stair-related “Accidents” in Homes (PowerPoint slide based on Wright and Roys, 2008)

The circles that I have superimposed on the Figure 2 graph depict the various tread depth (run or going) dimensions of various code criteria used in the USA and Canada. What is especially valuable about this graph is that it allows us to estimate the degrading of stairway safety due to the loss of say 1 inch or 25 mm of effective tread depth. For example, if the ICC minimum tread depth of 10 inches or 250 mm is used for a stair design in which the use of a 1/2-inch radius rounded nosing and a covering of a half-inch thick carpet results in an effective one-inch reduction, that would suggest approximately an increase of “accident” rate from 5 percent to about 11 percent, an effective doubling of the risk of an injurious stair-related fall compared to a square-nosing design without any covering. The conventional, NAHB-favored (by national NAHB policy) tread depth of 9 inches or 230 mm has about a 10 percent base rate of “accident” risk and, with the loss of an additional inch of tread depth, the risk rises to about 14 percent, nearly triple the risk of an IRC-complying tread depth with no loss of effective tread depth due to nosing rounding or beveling.

So, from this we can see the benefit to safety of limiting the loss of effective tread depth as carpet is installed. We should not install thick carpet on top of any already compromised tread with a large nosing rounding or beveling. Thus I am suggesting that anything over 9/16 inch—the current upper limit set in the IBC and IRC for loss of effective tread depth—should be compensated for by increasing the minimum tread depth stipulated in 1009.4.2 and R311-7.4.2. It should also be noted here that the step geometry work performed recently—described in my accompanying proposal on minimum tread depth and maximum rise limits, was based on nosings that ranged between a square design to a rounded 1/2 inch radius design. This is why my proposed language for Exceptions to Sections 1009.4.1 and R311.7.4, is based on the 9/16 inch limit for overall nosing radius or other loss of horizontal surface at the nosing (aside from the fact this is the current limit in 1009.4.5 and R311.7.4.3).

ICC members need to appreciate that the common practice of installing padded carpet on home stairs—prior to occupancy, without accounting for the detrimental safety effects of such installation is a kind of shell game. As home occupants we are not getting the safety benefits the code should be helping to guarantee. The fiction about effective tread depth dimensions on actually occupied, new home stairs has to stop so that the large, growing toll of home stair-related injuries can be brought under control in the same way that we are now beginning to tackle residual fire risks in new homes. Again, with home sprinklers we are spending considerably more to accomplish potentially much, much less in terms of injury prevention.

The overall ratio of home stair-related injuries is, again, about 50 times greater than the injuries from structural fires. And the latter rate has been dropping by about a half in the last few decades while stair-related injuries have been rising. Now, with the improvements made in the last decade or two with non-home stairways, we are finally seeing the same kind of reduction in injuries outside of homes that we have seen in homes and elsewhere with fire-related injuries. But home stair-related injuries are now rising several times faster than the roughly one percent or so we are beginning to see with reduction for stairs other than those serving homes. We have had, over the last several years, a slight reducing injury trend for all but home stairs contrasting with a very large increasing trend for home stair-related injuries.

Bibliography

Wright, M. and Roys, M. (2008). Accidents on English dwelling stairs are directly related to going size. In Bust, P.D. (ed.) *Contemporary Ergonomics 2008*. Taylor and Francis, 632-637.

Cost Impact: The code change proposal will slightly increase the cost of construction for stairs that are covered with thick carpet and possibly a pad underneath.

PART I – IBC MEANS OF EGRESS

Public Hearing:	Committee:	AS	AM	D
	Assembly:	ASF	AMF	DF

PART II – IRC BUILDING/ENERGY

Public Hearing:	Committee:	AS	AM	D
	Assembly:	ASF	AMF	DF

ICCFILENAME: Pauls-E2-1009.4.1

E73–09/10

1009.4.2 (IFC [B] 1009.4.2)

Proponent: Jake Pauls, representing self

Revise as follows:

1009.4.2 (IFC [B] 1009.4.2) Riser height and tread depth. Stair riser heights shall be 7 inches (178 mm) maximum and 4 inches (102 mm) minimum. The riser height shall be measured vertically between the ~~leading edges~~ nosings of adjacent treads. Rectangular tread depths shall be 11 inches (279 mm) minimum measured horizontally between the vertical planes of the foremost projection of adjacent treads and at a right angle to the tread's ~~leading edge~~ nosing. Winder treads shall have a minimum tread depth of 11 inches (279 mm) measured between the vertical planes of the foremost projection of adjacent treads at the intersections with the walkline and a minimum tread depth of 10 inches (254 mm) within the clear width of the stair.

Exceptions:

1. Alternating tread devices in accordance with Section 1009.10.
2. Ship ladders in accordance with Section 1009.11.
3. Spiral stairways in accordance with Section 1009.9.
4. Aisle stairs in assembly seating areas where the stair pitch or slope is set, for sightline reasons, by the slope of the adjacent seating area in accordance with Section 1028.11.2.
5. In Group R-3 occupancies; within dwelling units in Group R-2 occupancies; and in Group U occupancies that are accessory to a Group R-3 occupancy or accessory to individual dwelling units in Group R-2 occupancies; the maximum riser height shall be 7 ¾ inches (197 mm); the minimum tread depth shall be 10 inches (254 mm); the minimum winder tread depth at the walkline shall be 10 inches (254 mm); and the minimum winder tread depth shall be 6 inches (152 mm). A nosing projection not less than ¾ inch (19.1 mm) but not more than 1 ¼ inches (32 mm) shall be provided on stairways with solid risers where the tread depth is less than 11 inches (279 mm).
6. See Section 3404.1 for the replacement of existing stairways.
7. In Group I-3 facilities, stairways providing access to guard towers, observation stations and control rooms, not more than 250 square feet (23 m²) in area, shall be permitted to have a maximum riser height of 8 inches (203 mm) and a minimum tread depth of 9 inches (229 mm).

Reason: There is no technical change to the requirement in this proposal (although a separate proposal addresses technical issues). It is editorial with respect to replacement, in two places, of the old term "leading edge" with the now-defined term "nosing." There is also a clarification of intent in Exception 5 with the addition of the work "projection." There is a nosing, by definition; what the Code intends here is that there be a projection of such a nosing.

Bibliography

Wright, M. and Roys, M. (2008). Accidents on English dwelling stairs are directly related to going size. In Bust, P.D. (ed.) *Contemporary Ergonomics 2008*. Taylor and Francis, 632-637.

Cost Impact: The code change proposal will not increase the cost of construction.

Public Hearing:	Committee:	AS	AM	D
	Assembly:	ASF	AMF	DF

ICCFILENAME: Pauls-E3-1009.4.2

E74–09/10

1009.4.2 (IFC [B] 1009.4.2); IRC R311.7.4.1, R311.7.4.2

Proponent: Jake Pauls, representing self

THIS IS A 2 PART CODE CHANGE. PART I WILL BE HEARD BY THE IBC MEANS OF EGRESS COMMITTEE. PART II WILL BE HEARD BY THE IRC BUILDING/ENERGY COMMITTEE. SEE THE TENTATIVE HEARING ORDERS FOR THESE COMMITTEES.

PART I – IBC MEANS OF EGRESS

Revise as follows:

1009.4.2 (IFC [B] 1009.4.2) Riser height and tread depth. Stair riser heights shall be 7 inches (178 mm) maximum and 4 inches (102 mm) minimum. The riser height shall be measured vertically between the leading edges of adjacent treads. Rectangular tread depths shall be 11 inches (279 mm) minimum measured horizontally between the vertical planes of the foremost projection of adjacent treads and at a right angle to the tread's leading edge. Winder treads shall have a minimum tread depth of 11 inches (279 mm) measured between the vertical planes of the foremost projection of adjacent treads at the intersections with the walkline and a minimum tread depth of 10 inches (254 mm) within the clear width of the stair.

Exceptions:

1. Alternating tread devices in accordance with Section 1009.10.
2. Ship ladders in accordance with Section 1009.11.
3. Spiral stairways in accordance with Section 1009.9.
4. Aisle stairs in assembly seating areas where the stair pitch or slope is set, for sightline reasons, by the slope of the adjacent seating area in accordance with Section 1028.11.2.
5. In ~~Group R-3 occupancies; within dwelling units in Group R-2 occupancies; and in Group U occupancies~~ that are accessory to a Group R-3 occupancy or accessory to individual dwelling units in Group R-2 occupancies; the maximum riser height shall be 7 $\frac{3}{4}$ inches (197 mm); the minimum tread depth shall be 10 inches (254 mm); the minimum winder tread depth at the walkline shall be 10 inches (254 mm); and the minimum winder tread depth shall be 6 inches (152 mm). A nosing not less than $\frac{3}{4}$ inch (19.1 mm) but not more than 1 $\frac{1}{4}$ inches (32 mm) shall be provided on stairways with solid risers where the tread depth is less than 11 inches (279 mm).
6. See Section 3404.1 for the replacement of existing stairways.
7. In Group I-3 facilities, stairways providing access to guard towers, observation stations and control rooms, not more than 250 square feet (23 m²) in area, shall be permitted to have a maximum riser height of 8 inches (203 mm) and a minimum tread depth of 9 inches (229 mm).

PART II – IRC BUILDING/ENERGY

Revise as follows:

R311.7.4.1 Riser height. The maximum riser height shall be 7 inches (178 mm) ~~7 $\frac{3}{4}$ inches (196 mm)~~. The riser shall be measured vertically between leading edges of the adjacent treads. The greatest riser height within any flight of stairs shall not exceed the smallest by more than $\frac{3}{8}$ inch (9.5 mm).

R311.7.4.2 Tread depth. The minimum tread depth shall be 11 inches (279 mm) ~~10 inches (254 mm)~~. The tread depth shall be measured horizontally between the vertical planes of the foremost projection of adjacent treads and at a right angle to the tread's leading edge. The greatest tread depth within any flight of stairs shall not exceed the smallest by more than $\frac{3}{8}$ inch (9.5 mm). Consistently shaped winders at the walkline shall be allowed within the same flight of stairs as rectangular treads and do not have to be within $\frac{3}{8}$ inch (9.5 mm) of the rectangular tread depth.

Winder treads shall have a minimum tread depth of 11 inches (279 mm) ~~10 inches (254 mm)~~, measured between the vertical planes of the foremost projection of adjacent treads at the intersections with the walkline. Winder treads shall have a minimum tread depth of 6 inches (152 mm) at any point within the clear width of the stair. Within any flight of stairs, the largest winder tread depth at the walkline shall not exceed the smallest winder tread by more than $\frac{3}{8}$ inch (9.5 mm).

Reason: This is purely a technical change affecting maximum and minimum rise and tread depth dimensions respectively. This is the long overdue mainstreaming of the so-called "7-11" step geometry in terms of maximum rise and minimum tread depth. (The proponent has submitted a separate change proposal which simply formats and restates the current requirements; that proposal and this one should be dealt with separately or independently as their purposes and effects are different.)

Much has been written about this topic, especially around 2003 in relation to the IRC and the NFPA codes (NFPA 101 and NFPA 5000 which adopted this change to the mainstreamed "7-11" step geometry at that time. Since that day nobody has attempted to revert to pre-"7-11" criteria for dwelling unit stairs within NFPA and for non-dwelling unit stairs within ICC. The "7-11" minimum standard is the most widely used step geometry standard internationally and reasons for keeping it at least the minimum standard have grown. This is because all the recent research on use of stairs—including the matter of falls on stairs, including injurious ones—confirms that it is a very reasonable minimum standard and that it is a long way—about three inches or more—from an "optimum" standard.

The very extensive 2003 proposal I submitted to both ICC and NFPA is not reproduced within this proposal for reasons of length and, more importantly, its free availability on the Internet, specifically the Downloads area of my website, <http://web.me.com/bldguse>. Once within the Downloads area (where over a hundred PDF files can be freely downloaded on stairway usability and safety plus means of egress performance), simply open the folder titled, "Home Stairway Safety and Codes," and download the 3.4 MB, 40-page file, "Pauls-R311-2003.pdf." Here follows an outline of what was covered in that proposal which I submitted to ICC with NFPA getting a comparable, earlier one that was approved by NFPA members and withstood technical and procedural challenges from the NAHB.

- Benefit-Cost Analysis for Improved Stairs in the USA
- Injury Epidemiology
- History of Debate on Improved Step Geometry Requirements in Codes & Standards
- Benefits and Costs
- Industry's and Regulators' Reviews of Research
- Latest Research on Step Geometry from Britain
- Politically-driven Local and State Adoption Process
- Building and Marketing Improved Stairs
- The Problem of the Double Standard
- Intimidation of Building Officials
- Roles of NFPA and APHA
- Summary.

What Has Changed Since 2003?

The changes for the worse appear to be directly attributable to even worse home stair construction and regulation than existed before 2003. This is seen in Figure 1 which shows the growth of home stair-related injuries that are NOT due to the aging of the population—as this was checked out to learn that people under 65 and those 65 or more in age both contributed in more or less the same proportion to the substantial growth in home stair, related injuries. A recent, widely-circulated document described the statistical insights as follows: "For both 1997 and 2007, the percentage of NEISS-reported injuries for the 65-and-older group was 15.3 percent plus/minus 0.4 percent for both home settings and all settings." Thus, both before and after 1997, elderly persons were only slightly—but consistently—over-represented in hospital emergency department-treated injuries associated with stairs as reported in national estimates by the US Consumer Product Safety Commission. (The note, titled "The Home Stairway Safety Problem and Related Code Development, Adoption and Enforcement Problems in the USA," is also posted for free downloading from the website "<http://web.me.com/bldguse>" Downloads area as file "Pauls2009Letter&InjuryNote" within the folder titled, "Home Stairway Safety and Codes.") A list of the topics addressed therein is provided below Figure 1.

Figure 1 shows an extraordinary growth in the US national estimates from the US CPSC/NEISS for stair-related injuries, particularly in homes. The average annual rate of increase in the last several years exceeds the average annual rate of US population growth by a factor of about five while stair-related injuries in non-home settings decrease slightly, resulting in about a 2 percent reduction annually for non-home stairs over the last several years—since about 1998. During these several years there has been increasing use of the "7-11" minimum step geometry standard for non-home stairs, thanks to the adoption—beginning in the 1980s—of this standard in model building codes. This is further evidence of a partial success story on the stairway safety front and ICC members might rightly claim some of the credit for this partial success. Now building officials who control the adoption of the requirements in model codes need to finish the job where it will count most, in homes.

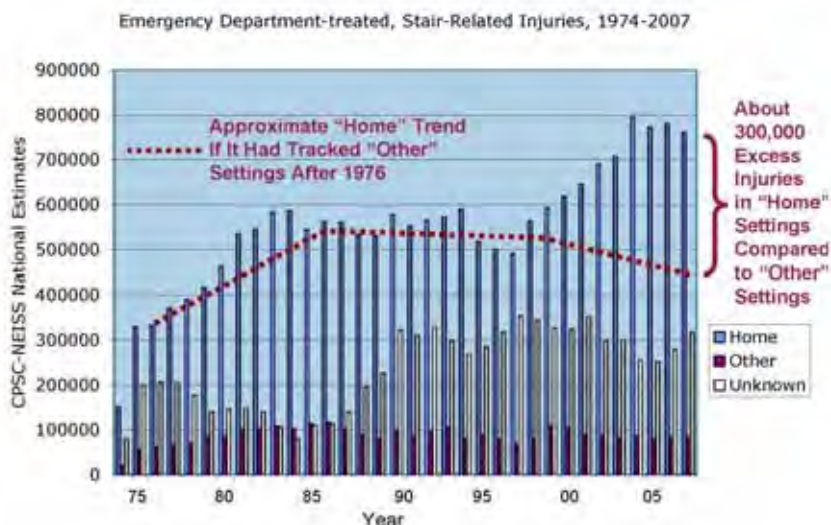

Figure 1. Growth of Home Stair-related Injuries in USA in Recent Years.

Updating the 2003 ICC proposal on mainstreaming the "7-11" minimum standard was the note which began circulating in February of 2009. Here are the topics it addressed in its 26 pages (including over two pages of references and additional resources).

Preface

Injury Epidemiology

CPSC-NEISS Data

Injury Increase Comparisons

Excess Injuries for Home Stairs

Are Recent Increases Due to the Aging Population?

Statistical Issues

Uncertainty in the NEISS Data

Societal Cost of Stair-related Injuries

Estimated Cost of Two Million Excess Home Stair-related Injuries, 1998 to 2007

Are We Finally Paying the Price for Code-triggered Defects in Home Stairways, Compared to Other Stairways?

In the Mostly Bleak, Stair Safety Field, A Possible Success Story in Non-home Settings

Why Are Home Stairways Relatively Dangerous?

The Role of Code Development, Adoption and Enforcement

History of Some Relatively Important Influences on Stairway Safety and Its Regulation

Step Geometry

Step Geometry Uniformity

Systemic Tread Run Non-uniformities Common in Many Recently Constructed Homes

Resulting Misstep and Fall Scenarios

Systemic Uniformity Defect Superimposed Upon Another Systemic Step Geometry Defect

An Abbreviated History of Step Geometry Rules and Related Issues

Homebuilders

Business Arrangement Between ICC and NAHB, Among Other Strategic Partners

NAHB Bias on ICC Committees Responsible for IRC

Hypocrisy in ICC's Business Deal with NAHB

Consumer-supplied Evidence of Step Geometry Efficacy

Combination of the NAHB-favored Short Stair Treads with Top-of-Flight

Non-uniformities and with Dysfunctional Handrail Systems

Recent Critique of Type II Handrails and Study Used to Justify Them

ICC Codes and Stairway Defects

What Homeowners Must Now See (beyond the failings of ICC and the code-based regulatory process generally).

With Flawed Code Inspection, Consumers Need to Do Their Own Stair Inspection

Recommendations: What ICC and Other Organizations Urgently Need to Do

Appendix A: Abbreviated History of Step Geometry Rules and Related Issues

Appendix B: Code of Ethics of International Code Council (ICC) and predecessor organization, Council of American Building Officials (CABO)

References and Guide to Resources.

The 2003 proposal to ICC, "Pauls-R311-2003," included substantial benefit-cost information about stair step geometry in homes which must be updated to take account of recent, dramatic growth in home stair-related injuries (in terms of CPSC-NEISS national estimates) as well as higher-than-general inflation rates for medical treatment costs. The latter are currently running at about \$1 million per hour in the USA with total, societal costs running at about \$10 million per hour in the USA.

Societal Cost of Stair-related Injuries. Currently, for the USA, the annual societal costs of home stair-related injuries—currently comprising about 89 percent of all stair-related injuries where the location or setting is known—are on the order of \$100 billion annually for comprehensive, societal costs. (The basis for the 89-percent figure is the NEISS data described above.) The basis for the societal cost (the sum of medical care costs, direct productivity losses and pain-and-suffering or quality of life costs) is a paper by Lawrence, *et al.* (1999). (Among coauthors for this paper are internationally recognized experts in burden of injury, like Ted Miller.) They estimated a societal cost (in 1997 dollars) of \$46.7 billion for stair-related injuries occurring in 1995. For that year the NEISS national estimate for US emergency department-treated, stair-related injuries was 892,610 for all settings and 517,641 for homes. Between 1995 and 2007 these increased, respectively, to 1,161,915 (a 30-percent increase) and 761,881 (a 47-percent increase). (These national estimates for 1995 are the "adjusted" ones obtained via the NEISS website; they correct for a change in NEISS sampling that took effect in January 1, 1997.)

Accounting also for inflation (of about 3 to 4 percent annually—although medical care increases were higher), we can assume that, for 2007, the societal costs for stair-related injuries in the USA were on the order of \$100 billion in 2007 dollars (including on the order of \$10 billion for medical care, \$20 billion for direct productivity losses, and \$70 billion for pain and suffering or quality of life costs—with this estimated distribution based on a personal communication with Bruce Lawrence and Ted Miller, among the authors of the above noted paper). This cost was about an order of magnitude greater than the annual construction cost of new stairs (just prior to the recent economic downturn) in the USA. For an analysis of home and stair construction costs see Pauls (2003). The smallest cost component, medical care, is about one million dollars per hour in the US."

Quoting also from the paper by Pauls, 2009 on "Injury Increase Comparisons: The apparent, relatively rapid increase recently in home stair-related injuries has an average annual growth rate of about 4.5%, a few times greater than annual population growth (1%). The overall increase, over a three-decade period, was about 130 percent with the most recent ten-year period showing a 55-percent increase. By contrast, fire-related injuries (the majority of which occur in homes), a major concern traditionally in safety standards and codes, have shown a three-decade pattern of average annual *decrease* of about 2 percent. (If fire-related injuries were plotted on Figure 1A, that plot would be appear very close to the base of the graph, declining from about 50,000 to about 25,000 annual injuries over a three-decade period.) Moreover, the trend for all NEISS injury national estimates for home settings—other than stairs, during the period 1997-2007 has a 39-percent increase over the same last ten-year period when home stair-related injuries increased by 55 percent. For *all* products and settings, the increase in NEISS national estimates over the same 1997-2007 period was only 19 percent, about the same as the 18-percent increase for stairs in other settings (i.e., not homes). From this, and other analyses the author has performed with the CPSC-NEISS data, we can see generally, that homes generally are the major site for injuries, relative to other settings; homes account for about 49 percent of the NEISS national estimates of injuries during the 1997-2007 period.

Aside from fire-related injuries—these NEISS-reported national estimates of all injuries in home settings are increasing faster than in other settings (39 percent versus 19 percent for all NEISS national estimates during the 1997-2007 period).

NEISS national estimates of stair-related injuries in home settings have been increasing over the last ten years at a fast rate relative to NEISS national estimates for all NEISS-coded products (55 percent versus 19 percent) and relative to population growth (55 percent versus 10 percent). Over the 1997-2007 period, NEISS national estimates of home stair-related injuries comprised 89 percent of NEISS national estimates for stair-related injuries in all known settings. For early years of NEISS national estimates, specifically 1975-1977, this was 85 percent. Most of the increase in this proportion occurred since 1990.

Generally, in recent years stairs have accounted for about 9 percent of the NEISS national estimates for all products; home stairs accounted for about 6 percent; other settings' stairs accounted for less than 1 percent; unknown settings' stairs accounted for over 2 percent. Stairs maintain their position, since the earliest days of CPSC-NEISS, as the leading product, associated with injuries coded by NEISS. Floors are the second leading category. See Lawrence, *et al.* (1999), Table 5, using data for 1995-1996, for an analysis for the top ten NEISS-coded products, ranked by injury cost, for various age groups. As well as ranking first for all ages, stairs rank first for 5 of 12 age groups (preschool children and middle-age adults) and second for another three. Only for the two highest age categories, 70-79 and 80 or more (for which stair use is relatively rare), do floors rank first, reflecting the contribution of gait and balance deterioration. However, stairs are still the second leading product for the 70-79 age group and third (after beds) for the 80-plus age group."

Laboratory and Field Research and Investigations of the Role of Step Geometry on Stairway Safety

The last several years have seen some important work on questions that have long troubled ICC members when addressing this issue of appropriate minimum standards for home step geometry. This work brings no comfort to those arguing that the minimum standards should stay as they are in the IRC and IBC or, even worse, that the NAHB's even lower standard should be the norm. The latter is based on NAHB's long-held national policy position which can be read directly on its website at "www.nahb.org/generic.aspx?sectionID=224&genericContentID=3093" (accessed June 1, 2009): "Support efforts by state and local affiliated Home Builder Associations to oppose the adoption of any new stair geometry that is not consistent with the requirements originally contained in the 1993 BOCA and 1992 CABO Codes by amending those provisions when adopting new editions of model building codes." This is the 8 1/4-inch maximum rise by 9-inch minimum tread depth that, especially with carpeting further degrading the usability and safety of the home stairs, makes them so dangerous and difficult to use. It is indeed beyond belief that, as the stair safety epidemic grows, the homebuilders insist on using a code that was out of date decades ago.

UK Research. Mike Roys and Mike Wright, UK Building Research Establishment have conducted some extraordinarily useful research in recent years, with the last of their papers published in May 2008. Working with a test stairway that offered 10 combinations of tread depth ("going" as it is called in the UK and "run" in some other places), in the range of 200 to 425 mm or 7.9 to 16.7 inches, with 6 combinations of rise height, in the range of 160 to 210 mm or 6.3 to 8.3 inches, they clearly showed the benefits of larger tread depths. Altogether, 60 adult subjects walked up and down each of 20 stair arrangements. Their work, while not completely published yet, is represented centrally in my recent one-day workshops on stairway usability and safety, the PowerPoint slides of which (including a fair selection of the BRE study slides) are available for downloading from my website in the folder titled, "Presentations at MUTN Conference in BC, Canada, April 2009." Papers on this work include Roys, 2001; Wright and Roys, 2005; and Wright and Roys, 2008. (Dr Wright moved to the USA in late 2008 so that now we are fortunate to have, in the USA, one of the top world talents in designing and conducting studies of step geometry and stair use performance.)

Answering a very old question in the code field, they showed that optimum tread depth in terms of many objective and subjective measures was much larger than 11 inches; 14 inches is about where this becomes optimum. The much-used 11-inch criterion is approximately where the graph of some of their findings, reproduced below as Figure 2, shows a change of direction from steep to more gradual slope and finally leveling off at the "optimum" tread depth of about 14 inches or 350 mm. This supports treating 11 inches as the minimum and clearly not the "optimum."

Figure 2. Graph of Findings from the UK Research by Wright and Roys, as Presented (in a PowerPoint) in 2005 at an International Conference on Falls in the UK.

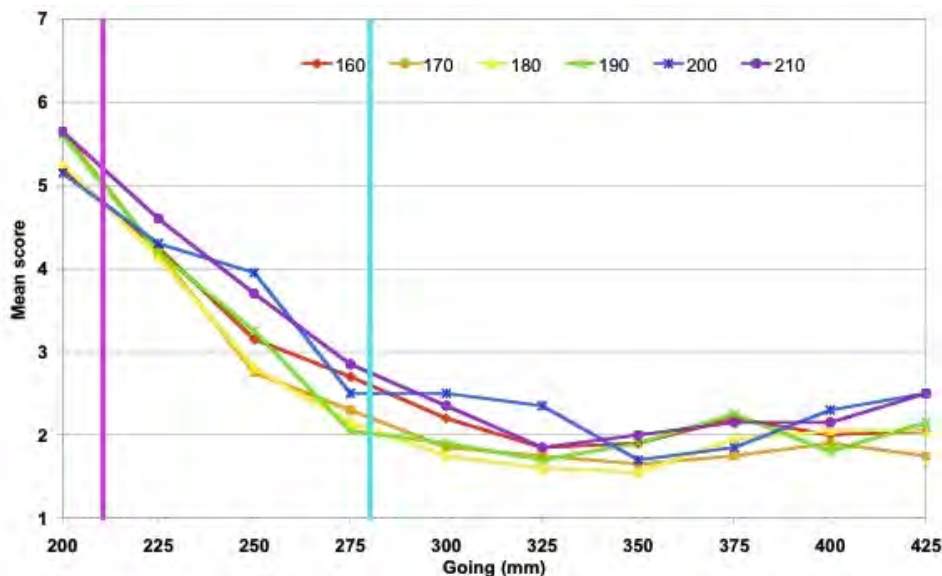

The responses plotted here are to the scaled remark, "I felt safe walking down the stair," with the "most-safe" responses at the bottom of the curves.

The most recent of their papers, Wright and Roys (2008), contains some of the most interesting and valuable work—in this case conducted in the field and inquiring into actual fall incidents as a function of home stairway rise and tread depth ("going" in the graph). This is shown in Figure 3, onto which I have superimposed some of the criteria for US and Canadian home stair minimum tread depth, the same range shown in Figure 2 with the vertical bars at the left half of the Figure, specifically at the 210 and 280 mm, 8 1/4 and 11-inch minimum tread depth criteria. Note that any rounding or beveling of the nosing and presence of carpet and pad (in some cases, especially on typical home stairs), the effective tread depth is significantly reduced from these values so that the effective tread depth of some home stairs, built to code, is as small as 180 mm or 7 inches. Incidentally, the testing that led to the results in Figure 2, were with uncarpeted treads with no more than 13 mm or 1/2 inch loss of effective tread depth due to rounding of the nosing. The safety differences among the various tread depths are large and cannot be ignored.

Figure 3. Role of Stair Tread Depth ("Going" in UK) in Stair-related "Accidents" in Homes (PowerPoint slide based on Wright and Roys, 2008)

Slide based on Figure 4 in paper by Wright and Roys, 2008

ACCIDENTS ON ENGLISH DWELLING STAIRS ARE DIRECTLY RELATED TO GOING SIZE

Canadian & US Dwelling Code Requirements

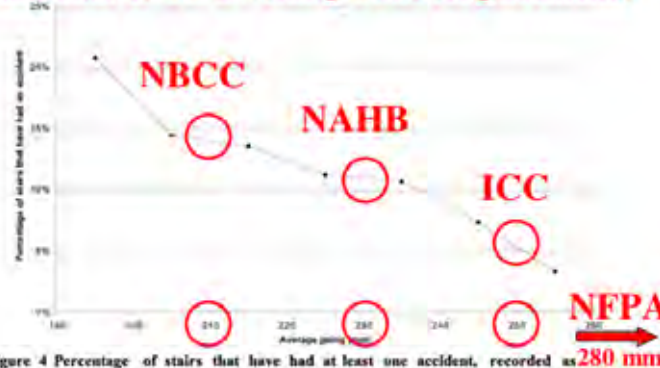

Figure 4 Percentage of stairs that have had at least one accident, recorded as taking place on them in the last two years, as a function of average going

Recent US Research on Step Geometry. While there are other studies that could be referenced and described here in relation to the step geometry issue, in the interests of time and space, I will note only one more. This was a paper based on 80 relatively intensively investigated stair-related fall injuries that led to litigation and subsequent investigation by one of the top three or so research and investigation experts in North America with excellent ergonomics credentials. The paper was published in January of 2009 *Professional Safety*, the peer-reviewed journal of the American Society of Safety Engineers and was titled, "Stairway Falls: an ergonomic analysis of 80 cases," by Cohen, LaRue and Cohen (2009). Among their conclusions they note: "In this analysis, excessive dimensional variation appeared to be the most pervasive factor in stairway fall causation, followed by noncompliance with the 7-11 design rule for risers and treads, respectively. As with dimensional variation, this investigation showed a tendency for staircase geometry to fall outside the recommended limits of established building codes. Therefore, stairs that do not follow these requirements are more likely to be involved in falls. It stands to reason that greater adherence to the criteria specified in existing codes (i.e., risers in the range of 7 in. and treads in the range of 11 in.) would decrease the number of actual stairway falls that occur. Therefore, it is essential for both architects and builders to adhere to existing codes regarding stairway dimensions. Furthermore, prevailing codes must be enforced by building code officials, plan checkers and field inspectors, since stair dimensions can often be overlooked in the haste to issue building occupancy permits."

Any ICC chapter wishing to have their members participate in a one-day workshop (also slated for presentation in Eastern Canada on September 14, 2009) should contact Jake Pauls. It is available in a not-for-profit mode. Code authorities should be prepared to deal knowledgeably with consumers who, upon discovering the defects in their home stairs, contact their local building department and ask for a re-inspection of their home stairways. If there has been an injurious fall on such a stairway they should also be prepared to deal with resulting legal actions that might name the local building department as a third party defendant. (ICC itself is also a potential third-party defendant—as are homebuilders and their trade associations—a matter taken up in the so-called "New Orleans Decalation" I issued in the spring of 2009 and posted on my website Downloads area.) Inspectors should at least know about how measurements of the stair step geometry are performed that are of a quality expected in such litigation actions. These measurement techniques, usually requiring use of a spirit level or electronic level, are all described in the workshop materials posted on the above-mentioned website Downloads area and on the DVD of the Spring 2009 workshop noted above. These measurement techniques are consistent with the ICC requirements both as currently stated and as further clarified if the package of proposals I put forward is accepted.

As indicated with all of the epidemiological and etiological work outlined in this proposal, the home stair-related injury issue is many times larger than is the home fire-related injury problem. It should thus be nearly a no-brainer, after adopting home sprinkler requirements, for responsible ICC members to vote for the mainstreaming of the "7-11" step geometry standard. I will be counting on such ICC members and others who can sway opinion to speak out with conviction based on the primacy of their duties to the public, the first item in the code of ethics for certified officials, a code which is available on my website if it cannot be located on ICC's.

Bibliography

- Cohen, J, LaRue, C.A. and Cohen, H.H. (2009). Stairway Falls: An ergonomic analysis of 80 cases. *Professional Safety*, Vol. 54, No. 1, January, pp. 27-32.
- Lawrence, B.A. et al. (1999). Estimating the costs of nonfatal consumer product injuries in the United States. *Proceedings of 7th International Conference on Product Safety Research*, September 30 - October 1, 1999, Washington, DC, pp. 97-113. Also, *Injury Control & Safety Promotion*, Vol. 7, No. 2, pp. 97-113.
- National Association of Home Builders (1995-2009). Codes and Standards Policy. NAHB, Washington, DC. www.nahb.org/generic.aspx?sectionID=224&genericContentID=3093 (Accessed June 1, 2009).
- Pauls, J. (2009). The Home Stairway Safety Problem and Related Code Development, Adoption and Enforcement Problems in the USA. Silver Spring, MD. (Posted for free downloading from the website "http://web.me.com/bldguse" Downloads area as file "Pauls2009Letter&InjuryNote" within the folder titled, "Home Stairway Safety and Codes.")
- Pauls, J. and Harbuck, S. (2008). Ergonomics-based Methods of Inspecting, Assessing and Documenting Environmental Sites of Injurious Falls Resulting from Missteps on Small Elevation Differences, Slopes and Steps. *Proceedings of the American Society of Safety Engineers Professional Development Conference & Exposition*, Las Vegas, NV, 2008. (Downloadable as file, "Pauls-Harbuck-ASSE-paper.pdf," from folder, "Home Stairway Safety and Codes," accessible from the Downloads area of <http://web.me.com/bldguse/Site/Downloads.html>.)
- Roys, M.S. (2001). Serious stair injuries can be prevented by improved stair design. *Applied Ergonomics*, Vol. 32, pp. 135-139.
- Wright, M. and Roys, M. (2005). Effect of changing stair dimensions on safety. In Bust, P.D. and McCabe (eds.) *Contemporary Ergonomics 2005*, Taylor and Francis Books, pp. 469-474.
- Wright, M. and Roys, M. (2008). Accidents on English dwelling stairs are directly related to going size. In Bust, P.D. (ed.) *Contemporary Ergonomics 2008*. Taylor and Francis, 632-637.

Cost Impact: The code change proposal will increase the cost of construction. However, more importantly, the change will lead to much larger benefits in injury reduction and usability, especially for older users.

PART I – IBC MEANS OF EGRESS

Public Hearing:	Committee:	AS	AM	D
	Assembly:	ASF	AMF	DF

PART II – IRC BUILDING/ENERGY

Public Hearing:	Committee:	AS	AM	D
	Assembly:	ASF	AMF	DF

ICCFILENAME: Pauls-E4-1012.3

E75–09/10

1009.4.5, 1009.4.5.1 (New), 1009.4.5.2 (New), 1009.4.5.3 (New) [IFC [B] 1009.4.5, 1009.4.5.1 (New), 1009.4.5.2 (New), 1009.4.5.3 (New)]; IRC R311.7.4.3, R311.7.4.3.1 (New), R311.7.4.3.2 (New), R311.7.4.3.3 (New)

Proponent: Jake Pauls, representing self

THIS IS A 2 PART CODE CHANGE. PART I WILL BE HEARD BY THE IBC MEANS OF EGRESS. PART II WILL BE HEARD BY IRC BUILDING/ENERGY COMMITTEE. SEE THE TENTATIVE HEARING ORDERS FOR THESE COMMITTEES.

PART I – IBC MEANS OF EGRESS

Revise as follows:

1009.4.5 (IFC [B] 1009.4.5) Nosing and Riser Profile. The radius of curvature at the leading edge of the tread shall be not greater than $\frac{9}{16}$ inch (14.3 mm). Beveling of nosings shall not exceed $\frac{9}{16}$ inch (14.3 mm). Risers shall be solid and vertical or sloped under the tread above from the underside of the nosing above at an angle not more than 30 degrees (0.52 rad) from the vertical. ~~The leading edge (nosings) of treads shall project not more than 1 ¼ inches (32 mm) beyond the tread below and all projections of the leading edges shall be of uniform size, including the leading edge of the floor at the top of a flight.~~

Exceptions:

- ~~1. Solid risers are not required for stairways that are not required to comply with Section 1007.3, provided that the opening between treads does not permit the passage of a sphere with a diameter of 4 inches (102 mm).~~
- ~~2. Solid risers are not required for occupancies in Group I-3 or in F, H and S occupancies other than areas accessible to the public. There are no restrictions on the size of the opening in the riser.~~
- ~~3. Solid risers are not required for spiral stairways constructed in accordance with Section 1009.9.~~
- ~~4. Solid risers are not required for alternating tread devices constructed in accordance with Section 1009.10.~~

1009.4.5.1 (IFC [B] 1009.4.5.1) Nosing Projection Size. The leading edge (nosings) of treads shall project not more than 1 ¼ inches (32 mm) beyond the tread below.

1009.4.5.2 (IFC [B] 1009.4.5.2) Nosing Projection Uniformity. All nosing projections of the leading edges shall be of uniform size, including the projections of the nosings leading edge of the floor at the top of a flight.

1009.4.5.3 (IFC [B] 1009.4.5.3) Solid Risers. Risers shall be solid.

Exceptions:

1. Solid risers are not required for stairways that are not required to comply with Section 1007.3, provided that the opening between treads does not permit the passage of a sphere with a diameter of 4 inches (102 mm).

2. Solid risers are not required for occupancies in Group I-3 or in Group F, H and S occupancies other than areas accessible to the public. There are no restrictions on the size of the opening in the riser.
3. Solid risers are not required for spiral stairways constructed in accordance with Section 1009.9.
4. Solid risers are not required for alternating tread devices constructed in accordance with Section 1009.10.

PART II – IRC BUILDING/ENERGY

Revise as follows:

R311.7.4.3 Nosing and Riser Profile. The radius of curvature at the nosing shall be no greater than $\frac{9}{16}$ inch (14 mm). ~~A nosing not less than $\frac{3}{4}$ inch (19 mm) but not more than 1 $\frac{1}{4}$ inches (32 mm) shall be provided on stairways with solid risers. The greatest nosing projection shall not exceed the smallest nosing projection by more than $\frac{3}{8}$ inch (9.5 mm) between two stories, including the nosing at the level of floors and landings. Beveling of nosings shall not exceed $\frac{1}{2}$ inch (12.7 mm). Risers shall be vertical or sloped under the tread above from the underside of the nosing above at an angle not more than 30 degrees (0.51 rad) from the vertical. Open risers are permitted, provided that the opening between treads does not permit the passage of a 4-inch diameter (102 mm) sphere.~~

Exceptions:

1. ~~A nosing is not required where the tread depth is a minimum of 11 inches (279 mm).~~
2. ~~The opening between adjacent treads is not limited on stairs with a total rise of 30 inches (762 mm) or less.~~

R311.7.4.3.1 Nosing Projection Size. A nosing projection of not less than $\frac{3}{4}$ inch (19 mm) but not more than 1 $\frac{1}{4}$ inches (32 mm) shall be provided on stairways with solid risers.

Exception: A nosing projection is not required where the tread depth is a minimum of 11 inches (279 mm).

R311.7.4.3.2 Nosing Projection Uniformity. The greatest nosing projection shall not exceed the smallest nosing projection by more than $\frac{3}{8}$ inch (9.5 mm) within each flight of stairs, including the nosing at the level of floors and landings.

R311.7.4.3.3 Open Risers. Open risers are permitted, provided that the opening between treads does not permit the passage of a 4-inch diameter (102 mm) sphere.

Exception: The opening between adjacent treads is not limited on stairs with a total rise of 30 inches (762 mm) or less.

Reason: There is no technical change to the requirements in this proposal. It is a clarification of intent by separating out and labeling the separate issues of (1) nosing and riser profile or shape, (2) nosing projection size, (3) nosing projection uniformity, and (3) open risers. Based on evidence of poor compliance and inspection, it has been confusing for various topics to be lumped together in one long paragraph.

My special concern here is the apparent widespread failure to build and inspect stairs with regard to uniformity of nosing projection, especially at the top of stair flights. For this reason alone, it is important for this section—with a few topics in one paragraph—to be divided into smaller pieces dealing with a smaller set of issues. It appears that the nosing projection uniformity issue— particularly omitting the nosing projection on the landing nosing—might be mostly responsible for the rapid growth of what I refer to as “Excess Injuries” in Figure 1. Over the several years where these “Excess Injuries” have been seen in the CPSC-NEISS national estimates, there have been a total of about 2 million such “Excess Injuries” which have an associated annual societal cost in the USA of about \$200 billion (yes, that is billion with a “b”) with the medical care component of these “Excess Injuries” accounting for about \$20 billion. (The substantial basis for these cost-of-injury estimates comes from the work of Lawrence, et al., 1999.)

Emergency Department-treated, Stair-Related Injuries, 1974-2007

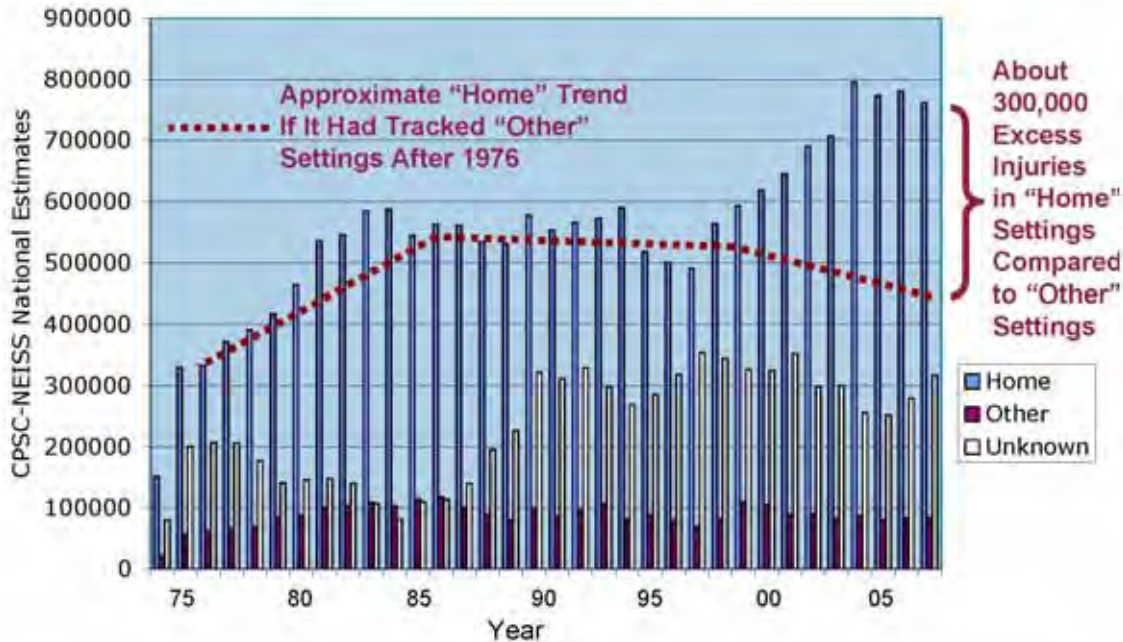

Figure 1. Growth of Home Stair-related Injuries in USA in Recent Years.

A far too common error in design and construction of stairways is the lack of attention to keeping all tread depths, especially the top one in a flight, uniform in size, particularly where projecting nosings are provided on a flight of stairs installed as a manufactured unit which does not include the top or landing nosing projection. Thus this is a dual issue of non-uniform tread depths and non-uniform nosing projections. ICC IRC guides for inspection and for the homebuilding industry (published by ICC in conjunction with NAHB) fail to even mention these two important IRC rules. These two ICC publications are listed in the Bibliography. Surely it is fairly strong evidence of a code inadequacy when even ICC experts apparently do not recognize the existence and importance of two rules governing the most potent of factors—step geometry uniformity—for the most dangerous product in homes and other buildings.

The resulting non-uniformities in tread depths, with a larger top tread followed by smaller treads in the flight make the stair flight orders of magnitude more dangerous for descent-direction users. This pervasive systemic defect has also become so concerning to leading stairway safety professionals such as myself that a special website page has been created simply to deal with this issue. See <http://web.me.com/bldguse/Site/Stairways.html> for information on this including the graph provided below as Figure 1 showing a large increase in the number of home stair-related injuries identified in the CPSC NEISS national estimates for the USA in the last several years. Excerpts of text from the Stairways website page are also quoted below as are excerpts from an American Society of Safety Engineers 2008 Professional Development Conference paper by Pauls and Harbuck. The full ASSE conference paper is freely accessible as a PDF download from the Downloads area of my website, <http://web.me.com/bldguse/Site/Downloads.html>. Generally, it is suspected that with recent greater use of manufactured stair flights, the incidence of systemic, top-of-flight non-uniformities has grown with resulting significant increases in home stair-related injuries.

On the Stairways website page, referenced above, is the following text and photograph (here identified as Figure 2) of a typical dwelling unit stairway with the systemic top-of-flight defect in nosing projection non-uniformity, the most common reason for the tread depth below the landing to be larger in size than the tread depths below it. Below Figure 2 is an additional photograph, Figure 3, showing what a stair flight looks like it very likely conforms to the uniformity requirements. The crouch-and-sight, visual test is helpful but is neither perfect nor quantitative; therefore, the stair geometry should be properly measured, at least at the top three steps, to confirm that there is not a rare coincidence of both larger tread depth and larger rise dimensions at the top step.



Figure 2. Typical Dwelling Unit Stairway with the Systemic, Top-of-Flight Defect.

Here follows the text from the website (<http://web.me.com/bldguse/Site/Stairways.html>) which has been publicly available since May 2009.

“While more investigation is required, it appears that a major reason for the recent ‘excess’ injuries related to home stairs might be a systemic defect on many home stairways (as well as some in other settings) in the USA and Canada. This defect is a non-uniformity of the nosing projection at the top of stair flights; due to the omission of a \$10 nosing piece, at the landing level, at the time of stairway construction. This makes the top tread below the landing effectively larger than all the steps below it.

This common defect greatly increases the risk of an ‘overstepping misstep’ on the second or third step down the flight. Such missteps can lead to a very serious fall down the stair flight, with resulting injuries.

This is why we should now give our stairways ‘a second look.’ Specifically we should perform the simple ‘crouch and sight’ test. Do this from the landing above the stair flight you wish to check. Crouch down so you are able to see all the stair nosings (the leading edges) line up. If the top, landing nosing does not line up with all the other step nosings, your stair likely has the systemic defect. Here is a home stairway with the systemic defect.”

The “Stairways” page of the website goes on to provide advice specifically for homeowners who perform the “crouch and sight” test and discover that their stairway has the systemic, top-of-flight defect.

“If your home stairway has this defect—which results from the non-uniformities of nosing projections and of what are called ‘tread depth’ or ‘run’ dimensions—and your home was recently constructed, call your local building inspection authorities and request that the stairway be re-inspected for building code compliance. Both the non-uniform nosing projection and the non-uniform tread depth or run are building code violations, for example under widely used codes in the USA.

If there has been a fall and significant injury on the non-uniform stair flight, you might also want to confer with an attorney (experienced in dealing with stair-related injury cases), especially if the home was recently constructed.

Much more information on this (and other) safety problems with stairways is found in the downloadable files associated with this website. See especially the latest papers and presentations by Jake Pauls on home stairways in the two most recently posted folders.

- Home Stairway Safety and Codes (Posted February 2009)
- Presentations at MUTN Conference in BC, Canada, April 2009

Also, in early summer 2009, watch this website for an announcement of the availability of an educational DVD package, based on the one-day workshop at the MUTN Conference in BC, Canada, in April 2009. (Contact Jake Pauls for purchase information.)”



Figure 3. Dwelling Unit Stair Very Likely Not Having the Systemic, Top-of-Flight Defect.

Any ICC chapter wishing to have their members participate in a one-day workshop (also slated for presentation in Eastern Canada on September 14, 2009) should contact Jake Pauls. It is available in a not-for-profit form. Code authorities should be prepared to deal knowledgeably with consumers who, upon discovering the systemic defect in their homes (after performing their own "crouch-and-sight" test), contact their local building department and ask for a re-inspection of their home stairways. If there has been an injurious fall on such a stairway they should also be prepared to deal with resulting legal actions that might name the local building department as a third party defendant. They should know how to perform the measurements of the stair step geometry that are of a quality expected in such litigation actions. These measurement techniques, usually requiring use of a spirit level or electronic level, are all described in the workshop materials posted on the above-mentioned website Downloads area and on the DVD of the Spring 2009 workshop noted above. These measurement techniques are consistent with the ICC requirements both as currently stated and as further clarified if this proposal is accepted.

In order to begin stopping all future misinterpretations of the IRC requirements for tread depth uniformity—and thus preventing many predictable and preventable missteps and falls (NOT "accidents" which are defined in the public health field as unpredictable and unpreventable events)—it is hoped that all code enforcement authorities heed very carefully the current and clarified requirements in IBC 109.4.5 (and 1009.4.2) as well as R311.7.4.2 (and R311.7.4.3).

Bibliography

ICC (2007). Residential Inspector's Guide Based on the 2006 IRC, Chapters 1-11. International Code Council, Washington, DC., ISBN 978-1-58001-568-4.
 ICC and NAHB. Home Builders' Jobsite Codes: a Pocket Guide to the 2006 International Residential Code. International Code Council, Washington, DC and National Association of Home Builders, Washington, DC.
 Lawrence, B.A. et al. (1999). Estimating the costs of nonfatal consumer product injuries in the United States. *Proceedings of 7th International Conference on Product Safety Research*, September 30 - October 1, 1999, Washington, DC, pp. 97-113. Also, *Injury Control & Safety Promotion*, Vol. 7, No. 2, pp. 97-113.
 Pauls, J. and Harbuck, S. (2008). Ergonomics-based Methods of Inspecting, Assessing and Documenting Environmental Sites of Injurious Falls Resulting from Missteps on Small Elevation Differences, Slopes and Steps. *Proceedings of the American Society of Safety Engineers Professional Development Conference & Exposition*, Las Vegas, NV, 2008. (Downloadable as file, "Pauls-Harbuck-ASSE-paper.pdf," from folder, "Home Stairway Safety and Codes," accessible from the Downloads area of <http://web.me.com/bldguse/Site/Downloads.html>.)

Cost Impact: The code change proposal will not increase the cost of construction as there is no technical change proposed. (The nosing piece required to comply with both the current code and the code as clarified by this proposal costs about \$10 per home stair flight in terms of material, in oak, at retail level.)

PART I – IBC MEANS OF EGRESS

Public Hearing:	Committee:	AS	AM	D
	Assembly:	ASF	AMF	DF

PART II – IRC BUILDING/ENERGY

Public Hearing:	Committee:	AS	AM	D
	Assembly:	ASF	AMF	DF

ICCFILENAME: PAULS-E1-1009.4.5.1

E76-09/10

1009.5 (IFC [B] 1009.5)

Proponent: David W. Cooper, Stair Manufacturing and Design Consultants, representing the Stairway Manufacturers' Association, Inc.

Revise as follows:

1009.5 (IFC [B] 1009.5) Stairway landings. There shall be a floor or landing at the top and bottom of each stairway. The width of landings shall not be less than the width of stairways they serve. Every landing shall have a minimum ~~dimension~~ width measured perpendicular to ~~in~~ the direction of travel equal to the width of the stairway. Where the stairway has a straight run the depth ~~Such dimension~~ need not exceed 48 inches (1219 mm) ~~where the stairway has a straight run.~~ Doors opening onto a landing shall not reduce the landing to less than one-half the required width. When fully open, the door shall not project more than 7 inches (178 mm) into a landing. When wheelchair spaces are required on the stairway landing in accordance with Section 1007.6.1, the wheelchair space shall not be located in the required width of the landing and doors shall not swing over the wheelchair spaces.

Exception: Aisle stairs complying with Section 1028.

Reason: This change clarifies that landing width is measured perpendicular to the line of travel. The commentary offers clarification of this language to reinforce the most common interpretation allowing the periphery of stairway landings to be curved or segmented because this does not reduce the effective width of the landing to those using the stairway. This proposal will allow more consistent application and enforcement of the intent of this section.

Cost Impact: This proposal will not increase the cost of construction.

Public Hearing: Committee:	AS	AM	D
Assembly:	ASF	AMF	DF

ICCFILENAME:Cooper-E3-1009.4

E77-09/10

1009.5 (IFC [B] 1009.5)

Proponent: Lee Kranz representing Washington Association of Building Officials (WABO), Technical Code Development Committee

Revise text as follows:

1009.5 (IFC [B] 1009.5) Stairway Landings. There shall be a floor or landing at the top and bottom of each stairway. The width of landings shall not be less than the width of stairways they serve. Every landing shall have a minimum dimension measured in the direction of travel equal to the width of the stairway. Such dimension need not exceed 48 inches (1219 mm) where the stairway has a straight run or where a curved stairway has a continuous radius. Doors opening onto a landing shall not reduce the landing to less than one-half the required width. When fully open, the door shall not project more than 7 inches (178 mm) into a landing. When wheelchair spaces are required on the stairway landing in accordance with Section 1007.6.1, the wheelchair space shall not be located in the required width of the landing and doors shall not swing over the wheelchair spaces.

Exception: Aisle stairs complying with Section 1028.

Reason: There are many curved or radius stairways that exceed the minimum required egress width. In those cases, to require the length of the landing in the direction of travel to be equal to the width of the stair is impractical and takes up valuable floor space. Per Section 1005.1, egress width must be maintained to the termination of the means of egress so changes in direction of the stair will not be allowed to be less than the width of the stair.

Cost Impact: The code change proposal will not increase the cost of construction.

Public Hearing: Committee:	AS	AM	D
Assembly:	ASF	AMF	DF

ICCFILENAME: KRANZ-E3-1009.5.DOC

E78–09/10

1009.10.2 (IFC [B] 1009.10.2)

Proponent: Elliott Mertz, Lapeyre Stair, representing self

Revise as follows:

1009.10.2 (IFC [B] 1009.10.2) Treads of alternating tread devices. Alternating tread devices shall have a minimum projected tread of 5 inches (127 mm), a minimum tread depth of 8 ½ inches (216 mm), a minimum tread width of 7 inches (178 mm) and a maximum riser height of 9 ½ inches (241 mm). The projected tread depth shall be measured horizontally between the vertical planes of the foremost projections of adjacent treads ~~the tread being measured and the tread directly above the tread being measured~~. The riser height shall be measured vertically between the leading edges of adjacent treads. The combination of riser height and projected tread depth provided shall result in an alternating tread device angle that complies with Section 1002. The initial tread of the device shall begin at the same elevation as the platform, landing or floor surface.

Exception: Alternating tread devices used as an element of a means of egress in buildings from a mezzanine area not more than 250 square feet (23 m²) in area which serves not more than five occupants shall have a minimum projected tread of 8 ½ inches (216 mm) with a minimum tread depth of 10 ½ inches (267 mm). The rise to the next alternating tread surface should not be more than 8 inches (203 mm).

Reason: Clarify the code. The only way to measure the projected tread depth of alternating tread devices is using treads that are directly above and below each other rather than adjacent treads which are to the side of each other. An adjacent tread has no effect on the usable depth of a tread adjacent.

Cost impact: The code change proposal will not affect the cost of construction.

Public Hearing: Committee:	AS	AM	D
Assembly:	ASF	AMF	DF

ICCFILENAME:Mertz-E2-1009.10.2

E79–09/10

1009.10.2 (IFC [B] 1009.10.2)

Proponent: David W. Cooper, Stair Manufacturing and Design Consultants, representing the Stairway Manufacturers' Association, Inc.

Revise as follows:

1009.10.2 (IFC [B] 1009.10.2) Treads of alternating tread devices. Alternating tread devices shall have a minimum ~~projected tread~~ depth of 5 inches (127 mm), a minimum projected tread depth of 8 ½ inches (216 mm), a minimum tread width of 7 inches (178 mm) and a maximum riser height of 9 ½ inches (241 mm). The ~~projected~~ tread depth shall be measured horizontally between the vertical planes of the foremost projections of adjacent treads. The riser height shall be measured vertically between the leading edges of adjacent treads. The ~~combination of~~ riser height and ~~projected~~ tread depth provided shall result in an ~~alternating tread device~~ angle of ascent from the horizontal that complies with Section 1002. The initial tread of the device shall begin at the same elevation as the platform, landing or floor surface.

Exception: Alternating tread devices used as an element of a means of egress in buildings from a mezzanine area not more than 250 square feet (23 m²) in area which serves not more than five occupants shall have a minimum ~~projected tread depth of 3.0 inches (76 mm) of 8 ½ inches (216 mm)~~ with a minimum projected tread depth of 10 ½ inches (267 mm). The rise to the next alternating tread surface should not be more than 8 inches (203 mm).

Reason: Currently in this section the code recognizes that "projected tread depth" is the distance measured horizontally between the vertical planes of the foremost projections of adjacent treads. This is what the code cites as being "tread depth" in both the stairway and ship ladder sections.

Alternating tread devices, ships ladders, and stairs have several things in common. They are vertical egress devices, they all have treads, and ascend at an angle. Mathematically any angle or slope can be defined by two components called Rise and Run. When calculating an angle it is these two components that are used. In reference to stairs and ladders of all types the horizontal component is usually called Run or Going however the ICC recognizes and substitutes the term "tread depth" for this horizontal unit of the slope that is used to calculate the angle.

If tread depth is the given term used in the ICC codes then it should and can be used correctly and in the same fashion for alternating tread devices, ships ladders and stairs.

The changes above simply correct long mistaken use of terms in this section that were amplified by changes made to this section in 2009 in an attempt to describe how to measure the tread depth.

Please see the graphics attached that provide additional clarification of this proposal in relation to the referenced definition of Alternating tread device in section 1002.

ALTERNATING TREAD DEVICE. A device that has a series of steps between 50 and 70 degrees (0.87 and 1.22 rad) from horizontal, usually attached to a center support rail in an alternating manner so that the user does not have both feet on the same level at the same time.

To assure that the device meets the definition it is necessary to calculate the angle of ascent from the horizontal. The corrected language makes this possible.

Referenced definition from Section 1002:

ALTERNATING TREAD DEVICE. A device that has a series of steps between 50 and 70 degrees (0.87 and 1.22 rad) from horizontal, usually attached to a center support rail in an alternating manner so that the user does not have both feet on the same level at the same time.

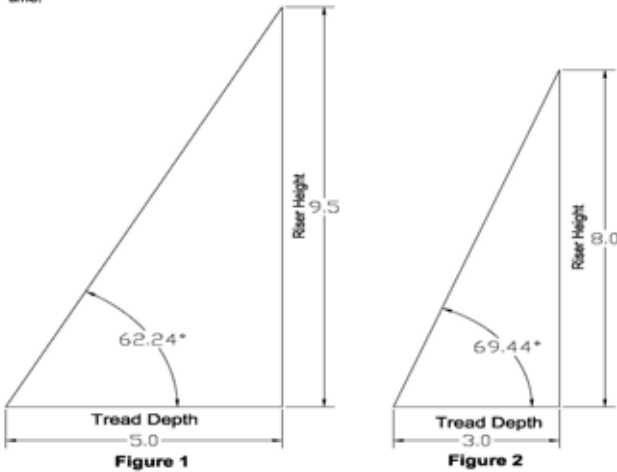

Figures 1 and 2 show the two tread depths and riser heights as corrected by the proposal and the related angles of ascent with the horizontal that are applicable to the referenced definition in Section 1002 for Alternating tread devices.

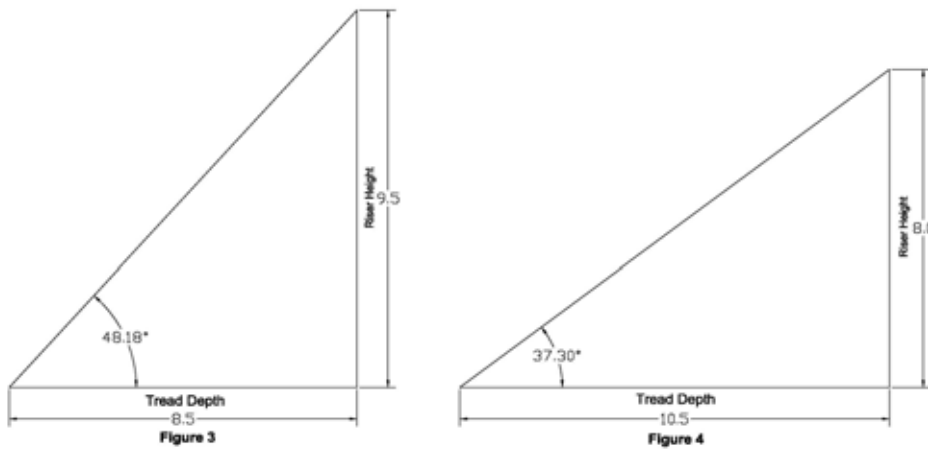

Figures 3 and 4 above show the two tread depths and riser heights as currently stated in the code and the resultant incorrect angles calculated. These errant angles do not match the devices angle nor do they fit the referenced definition in Section 1002 for Alternating tread devices.

Cost Impact: The code change proposal will not increase the cost of construction.

Public Hearing: Committee: AS AM D
 Assembly: ASF AMF DF

ICCFILENAME:Cooper-E1-1009.9.2

E80-09/10

1009.12, 1010.8, 1028.13 (IFC [B] 1009.12, 1010.8, 1028.13)

Proponent: Ed Roether, Populous (Formerly HOK Sport Venue Event), representing self

Revise as follows:

1009.12 (IFC [B] 1009.12) Handrails. Stairways shall have handrails on each side and shall comply with Section 1012. Where glass is used to provide the handrail, the handrail shall also comply with Section 2407.

Exceptions:

1. Handrails for aisle stairs ~~are not required where permitted by~~ provided in accordance with Section 1028.13.
2. Stairways within dwelling units, and spiral stairways ~~and aisle stairs serving seating only on one side~~ are permitted to have a handrail on one side only.
3. Decks, patios and walkways that have a single change in elevation where the landing depth on each side of the change of elevation is greater than what is required for a landing do not require handrails.
4. In Group R-3 occupancies, a change in elevation consisting of a single riser at an entrance or egress door does not require handrails.
5. Changes in room elevations of three or fewer risers within dwelling units and sleeping units in Group R-2 and R-3 occupancies do not require handrails.

1010.8 (IFC [B] 1010.8) Handrails. Ramps with a rise greater than 6 inches (152 mm) shall have handrails on both sides. Handrails shall comply with Section 1012.

Exception: Handrails for ramped aisles ~~are not required where permitted by~~ provided in accordance with Section 1028.13.

1028.13 (IFC [B] 1028.13) Handrails. Ramped aisles having a slope exceeding one unit vertical in 15 units horizontal (6.7-percent slope) and aisle stairs shall be provided with handrails in compliance with Section 1012 located either at the side or within the aisle width.

Exceptions:

1. Handrails are not required for ramped aisles having a gradient no greater than one unit vertical in eight units horizontal (12.5-percent slope) and seating on both sides.
2. Handrails are not required if, at the side of the aisle, there is a guard that complies with the graspability requirements of handrails.
3. Handrail extensions are not required at the top and bottom of aisle stairs and aisle ramp runs to permit crossovers within the aisles.

1028.13.1 (IFC [B] 1028.13.1) Discontinuous handrails. Where there is seating on both sides of the aisle, the handrails shall be discontinuous with gaps or breaks at intervals not exceeding five rows to facilitate access to seating and to permit crossing from one side of the aisle to the other. These gaps or breaks shall have a clear width of at least 22 inches (559 mm) and not greater than 36 inches (914 mm), measured horizontally, and the handrail shall have rounded terminations or bends.

1028.13.2 (IFC [B] 1028.13.2) Intermediate handrails. Where handrails are provided in the middle of aisle stairs, there shall be an additional intermediate handrail located approximately 12 inches (305 mm) below the main handrail.

Reason: The handrail requirements for aisle stairs and ramps differ from the handrail requirements for stairs since aisles serve seating to the side of an aisle stair or ramp. The occupant movement between the seating area and the aisle requires unique and specific requirements from that of a stair. Therefore, the exception should not be based upon where a handrail is permitted to be omitted, but rather that the handrail is required to comply with the handrail provisions for aisle stairs and ramps, not the handrail provisions for stairs. Also, there is more clarity by eliminating the portion pertaining to aisle stairs serving seating on one side from the exception pertaining to stairs in dwelling units and spiral stairs. By simply requiring compliance with the section on aisle handrail requirements there is no need for having the aisle serving seating on one side connected with a stair exception. Finally, Section 1028.13 should clearly require compliance with Section 1012 to fully separate and coordinate the requirements for stair handrails and aisle handrails.

Cost Impact: The code change proposal will not increase the cost of construction.

Public Hearing:	Committee:	AS	AM	D
	Assembly:	ASF	AMF	DF

ICCFILENAME:Roether-E7-1009.12

E81-09/10

1009.12, 1010.8 (IFC [B] 1009.12, 1010.8)

Proponent: Bill Conner, representing American Society of Theatre Consultants

Revise as follows:

1009.12 (IFC [B] 1009.12) Handrails. Stairways shall have handrails on each side and shall comply with Section 1012. Where glass is used to provide the handrail, the handrail shall also comply with Section 2407.

Exceptions:

1. Handrails for aisle stairs are not required where permitted by Section 1028.13.
2. Stairways providing access between the stage and the assembly seating area are permitted to have a handrail on one side only.
- 3.2. Stairways within dwelling units, spiral stairways and aisle stairs serving seating only on one side are permitted to have a handrail on one side only.
- 4.3. Decks, patios and walkways that have a single change in elevation where the landing depth on each side of the change of elevation is greater than what is required for a landing do not require handrails.
- 5.4. In Group R-3 occupancies, a change in elevation consisting of a single riser at an entrance or egress door does not require handrails.
- 6.5. Changes in room elevations of three or fewer risers within dwelling units and sleeping units in Group R-2 and R-3 do not require handrails.

1010.8 (IFC [B] 1010.8) Handrails. Ramps with a rise greater than 6 inches (152 mm) shall have handrails on both sides. Handrails shall comply with Section 1012.

Exceptions:

1. Handrails for ramped aisles are not required where permitted by Section 1028.13.
2. Ramps providing access between the stage and the assembly seating area are permitted to have a handrail on one side only.

Reason: Guards are not required on the front of a stage. Traditionally stairs or ramps leading to the stage have only had a handrail on the wall side to that they do not obstruct view of the stage. Sometimes ramps that wing a stage are also used as part of the stage during events. While single handrails are permitted in aisle steps within the seating areas, it is interpretive if the stairs to the stage are covered by this allowance. This proposal will clarify the issue.

Cost Impact: The code change proposal will not increase the cost of construction.

Public Hearing: Committee:	AS	AM	D
Assembly:	ASF	AMF	DF

ICCFILENAME:Conner-E3-1028.13 split

E82-09/10

1009.12 (IFC [B] 1009.12)

Proponent: Kyle Hantz, PE, General Services Administration, representing self

Revise as follows:

1009.12 (IFC [B] 1009.12) Handrails. Stairways shall have handrails on each side and shall comply with Section 1012. Where glass is used to provide the handrail, the handrail shall also comply with Section 2407.

Exceptions:

1. Handrails for aisle stairs are not required where permitted by Section 1028.13.
2. Stairways within dwelling units, spiral stairways and aisle stairs serving seating only on one side are permitted to have a handrail on one side only.
3. ~~Decks, patios and walkways that have a single change in elevation where the landing depth on each side of the change of elevation is greater than what is required for a landing do not require handrails.~~

3.4. In Group R-3 occupancies, a change in elevation consisting of a single riser at an entrance or egress door does not require handrails.

4.5. Changes in room elevations of three or fewer risers within dwelling units and sleeping units in Group R-2 and R-3 do not require handrails

Reason: Refer to NFPA 101 7.2.2.4.1.1. This states stairs and ramps have handrails. Yet 1009.12 exception #3 allows one change of elevation not to have a handrail. I think Exception #3 is referring to walkways that are not a component of a means of egress.

Cost Impact: The code change proposal will not increase the cost of construction.

Public Hearing: Committee:	AS	AM	D
Assembly:	ASF	AMF	DF

ICCFILENAME: Hantz-E1-1009.12.doc

E83–09/10

1009.12 (IFC [B] 1009.12)

Proponent: Ali M. Fattah, City of San Diego, representing SD Area Chapter ICC Code Committee

Revise as follows:

1009.12 (IFC [B] 1009.12) Handrails. Stairways shall have handrails on each side and shall comply with Section 1012. Where glass is used to provide the handrail, the handrail shall also comply with Section 2407.

Exceptions:

1. Handrails for aisle stairs are not required where permitted by Section 1028.13.
2. Stairways within dwelling units, spiral stairways and aisle stairs serving seating only on one side are permitted to have a handrail on one side only.
3. Decks, patios and walkways that have a single change in elevation where the landing depth on each side of the change of elevation is greater than what is required for a landing do not require handrails.
4. In Group R-3 occupancies, a change in elevation consisting of a single riser at an entrance or egress door does not require handrails.
5. Changes in room elevations of three or fewer risers within dwelling units and sleeping units in Group R-2 and R-3 do not require handrails.
6. At individual dwellings and their accessory structures, exterior stairways that are located on grade and do not provide the only means of egress to the public way do not require handrail.

Reason: The proposed code change adds clarity to the IBC. Exterior stairways on grade do not require handrails since the fall potential is not as critical on elevated stairways. There will be no obscuration of exterior path in a fire emergency s would be in an interior stairway. The IRC does not regulate exterior means of egress and flatwork.

Cost Impact: The code change proposal will not increase the cost of construction.

Public Hearing: Committee:	AS	AM	D
Assembly:	ASF	AMF	DF

ICCFILENAME:Fattah-E2-1012.1

E84–09/10

1009.12 (IFC [B] 1009.12)

Proponent: Don Birdsall, LIFT-U Division, Hogan Mfg., Inc., representing self

Revise as follows:

1009.12 (IFC [B] 1009.12) Handrails. Stairways shall have handrails on each side and shall comply with Section 1012. Where glass is used to provide the handrail, the handrail shall also comply with Section 2407.

Exceptions:

1. Handrails for aisle stairs are not required where permitted by Section 1028.13.

2. Stairways within dwelling units, spiral stairways and aisle stairs serving seating only on one side are permitted to have a handrail on one side only.
3. Decks, patios and walkways that have a single change in elevation where the landing depth on each side of the change of elevation is greater than what is required for a landing do not require handrails.
4. In Group R-3 occupancies, a change in elevation consisting of a single riser at an entrance or egress door does not require handrails.
5. Changes in room elevations of three or fewer risers within dwelling units and sleeping units in Group R-2 and R-3 do not require handrails.
6. Changes in elevation of one or two risers where there is an adjacent support on at least one side with a height of not less than 34 inches (864 mm) and not more than 42 inches (1067 mm) and with a top surface that complies with the graspability requirements of a handrail.

Reason: To eliminate the requirement of a handrail on a one or two step stairway when there is a fixed structure in place along the step(s) that can be grasped and used to support the user. A prime example of the situation is in a courtroom. To gain access to the Judges' Bench, the Judge may walk through the Witness Stand or Clerks' Station on one side of his Bench. The elevation change is typically two steps or less. If a wheelchair lift is present in the Witness Stand or Clerks' Station, a hazard is created between the fixed handrail and the wheelchair/user as the platform rises in height to the Judges' Bench. The millwork throughout the Bench area provides horizontal surfaces that can be used for support as would a handrail. By eliminating the requirement for handrails when there are support surfaces available, a potential crushing hazard between the handrail and the wheelchair user is eliminated while protecting the decorum of the courtroom.

Cost Impact: The code change proposal will not increase the cost of construction.

Public Hearing:	Committee:	AS	AM	D
	Assembly:	ASF	AMF	DF

ICCFILENAME: BIRDSALL-E1-1009.12.DOC

E85-09/10

1009.13 (IFC [B] 1009.13)

Proponent: David S. Collins, FAIA, The Preview Group, Inc., representing The American Institute of Architects

Revise as follows:

1009.13 (IFC [B] 1009.13) Stairway to roof. In buildings four or more stories above grade plane, one stairway shall extend to the roof surface, unless the roof has a slope steeper than four units vertical in 12 units horizontal (33-percent slope). In buildings four stories or more above grade plane, without an occupied roof, access to the roof from the top story shall be permitted to be by an alternating tread device or ladder.

Reason: The second sentence in Section 1009.13 isn't clear as to what it applies to; buildings four or more stories above grade plane, buildings of any height, or any building without an occupied roof? The proposed amendment clarifies the criteria to apply to buildings four stories above grade plane and having an unoccupied roof.

Cost Impact: The code change proposal will not increase the cost of construction.

Public Hearing:	Committee:	AS	AM	D
	Assembly:	ASF	AMF	DF

ICCFILENAME:Collins-E4-1009.13

E86-09/10

1009.13 (IFC [B] 1009.13)

Proponent: J. Nigel Ellis, Ph.D., PE, Ellis Fall Safety Solutions, LLC

Revise as follows:

1009.13 (IFC [B] 1009.13) Stairway to roof. In buildings four or more stories above grade plane, one stairway shall extend to the roof surface, unless the roof has a slope steeper than four units vertical in 12 units horizontal (33-percent slope). In buildings without an occupied roof, access to the roof from the top story shall be permitted to be by an alternating tread device. Hatch openings shall be provided with a means to facilitate access and exit such as ladder grab bars that can be grasped by the climber. Ladder grab bars shall be elevated above the roof and horizontally arranged in a uniform manner.

Reason: The code is presently silent on roof hatch fall hazards.

To avoid necessity for crouching to stabilize balance before entering the roof hatch or to reduce the incidence of tripping on the curb before descending, he externally mounted grab bars can be reached without stooping to permit access or bodily turn around with reduced falling hazard; such fall hazard can be up to 30 ft. in some mental buildings with highly injurious or fatal consequences.

The requirement would also apply to fixed ladder roof hatch access where exemptions to the IBC Code are permitted.

ANSI A14.3 – 2008 Section 5.3.4.3 states the following: "5.3.4.3 Hatch opening shall be provided with a means to facilitate access and exit from a fixed ladder (i.e, grab bars or other such items that can be grasped by the climber."

The University of Michigan Biomechanics Laboratory research report 4/08 financed by NIOSH (awarded by The Center to Protect Worker Rights) supports the selection of effective horizontal grab bars over ineffective vertical grab bars. NIOSH/CDC is the National Institute of Occupational Safety & Health/Center for Disease Control.

A picture of ladder grab bars for roof hatch access is attached for a commercial building roof hatch. Ladder grab bars have been recognized for decades in industry by OSHA and ANSI known simply as "grab bars". Since 1971, OSHA 1910.27(b)(5) and (d)(4) only has "grab bars" in mind for fixed ladders which are typically 12 inches long, one inch diameter, bolted or welded at each end and 1.5-4" space to grab where a fixed ladder is used. I am proposing that these ladder grab bars only be placed horizontally. Side rails are always vertically arranged which when grasped is a hazard when you fall more than approx. six inches because the hand slides as shown in the University of Michigan ladder report which I submitted electronically to ICC with the file name UM_CPWR_Final1.pdf and can be viewed on the FallSafety.com website under Ladder Improvements. CPWR (Center for Protection of Worker Rights) dispenses NIOSH grants for research. Another reference is the US Corps of Engineers EM385-1-1 (2003) (mandatory) Appendix Fixed Ladder and Stairs J3(h) "Openings shall be provided with elevated horizontal grab bars to facilitate access and exit from upper levels", J4(d) Horizontal grab bars shall be provided to facilitate grip in case of a fall".

I also understand the use of the term "grab bar" since 1990 approx. for bathroom safety rails in the building code and to which no reference is made in this proposal.

ANSI (American National Standards Institute) has used the term "grab bars" for ladder holding stability (when rungs and side rails were not available) since 1956 in the A14.3 fixed ladder standard, as defined in section 2 as follows: "2.14 Grab Bars are individual handholds placed adjacent to or as an extension above ladders for the purpose of providing access beyond the limits of the ladder"

Fixed ladder grab bars are addressed in proposed OSHA standard 1910.23(c)(21), and alternating tread type stairs are addressed in ANSI A1264.1-2007 section 6 and also proposed OSHA Standard 1910.25(f) and Fig. D3 (4 10 90). OSHA/DOL is the Occupational Safety & Health Administration/Department of Labor.

Horizontal grab bars can be attached by bolting or welding to protective guardrails arranged around roof openings for access to and from alternating tread devices and fixed ladders. More information on www.FallSafety.com Ladder Improvements related to ladder horizontal grab bars.



Cost Impact: Roof Hatch grab bars permanently installed approximately \$320 cost and four bolt holes to drill for installation. Where guardrails are added around the roof hatch, the total system costs approximately \$1300 before installation.

Public Hearing: Committee:	AS	AM	D
Assembly:	ASF	AMF	DF

ICCFILENAME:Ellis-E1-1009.12

E87–09/10

1010.1 (IFC [B] 1010.1)

Proponent: Jon Siu, City of Seattle, representing Washington Association of Building Officials Technical Code Development Committee

Revise as follows:

1010.1 (IFC [B] 1010.1) Scope. The provisions of this section shall apply to ramps used as a component of a means of egress.

Exceptions:

1. Other than ramps that are part of the accessible routes providing access in accordance with Sections 1108.2 through 1108.2.4 and 1108.2.6, ramped aisles within assembly rooms or spaces shall conform with the provisions in Section 1028.11.
2. Curb ramps shall comply with ICC A117.1.
3. Vehicle ramps in parking garages for pedestrian exit access shall not be required to comply with Sections 1010.3 through 1010.9 when they are not an accessible route serving accessible parking spaces, or other required accessible elements or part of an accessible means of egress.
4. In a parking garage where one accessible means of egress serving accessible parking spaces or other accessible elements is provided, a second accessible means of egress serving that area shall be permitted to include a vehicle ramp that does not comply with Sections 1010.4 through 1010.8.

Reason: This proposal solves a practical problem with current code language. In parking garages where parking is provided on the ramps, the accessible parking spaces are usually located on flat areas at the ends of the ramps. One accessible means of egress can usually be easily provided on the flat portion of the garage ramp. However, many times the second required means of egress is provided at the other end or at the center of the garage, and is accessed via the vehicle ramp. While the ramp may be able to provide the correct slope to provide the second accessible means of egress from the accessible parking spaces (1 vertical in 12 horizontal), it is impractical in these types of garages to provide features such as handrails on both sides of the ramp, or to provide a landing for every 30 inches of rise.

The proposed text is modeled on Section 1010.1 exception 3, which allows the deletion of the some provisions for vehicle ramps used as exit access for pedestrians. However, because the ramp still needs to be used as an accessible means of egress, it is necessary to maintain a usable cross-slope (Section 1010.3). In addition, protection at the edges of the ramp should still be provided where the accessible means of egress is along the edge of the vehicle ramp (Section 1010.9). On the other hand, if the accessible means of egress is not near the edge of the vehicle ramp (the most likely scenario), Section 1010.9, Exception 1 can be used to eliminate the edge protection, since the requirement for 1:10 sloped "flares" will easily be met.

Cost Impact: The code change proposal will not increase the cost of construction.

Public Hearing:	Committee:	AS	AM	D
	Assembly:	ASF	AMF	DF

ICCFILENAME: SIU-E1-1010.1

E88-09/10

1010.1 (IFC [B] 1010.1)

Proponent: Ali M. Fattah, City of San Diego, representing SD Area Chapter ICC Code Committee

Revise as follows:

1010.1 (IFC [B] 1010.1) Scope. The provisions of this section shall apply to ramps used as a component of a means of egress.

Exceptions:

1. Other than ramps that are part of the accessible routes providing access in accordance with Sections 1108.2 through 1108.2.4 and 1108.2.6, ramped aisles within assembly rooms or spaces shall conform with the provisions in Section 1028.11.
2. Curb ramps shall comply with ICC A117.1.
3. Vehicle ramps in parking garages for pedestrian exit access shall not be required to comply with Sections 1010.3 through 1010.9 when they are not an accessible route serving accessible parking spaces, other required accessible elements or part of an accessible means of egress.
4. Sloped driveways used for vehicular access to Group U occupancies or private garages, that are associated with Group R-3 dwelling units that are not required to meet Type B unit requirements in Section 1107, shall not be required to comply with this section.

Reason: The proposed code change adds clarity to the IBC. This requirement existed under the 1997 UBC but was not enforced. The IRC does not regulate exterior means of egress. It is not practical on single family dwellings and two-family dwellings to provide egress ramps.

Cost Impact: This proposal will minimally impact the cost of construction.

Public Hearing:	Committee:	AS	AM	D
	Assembly:	ASF	AMF	DF

ICCFILENAME:Fattah-E3-1010.1

E89–09/10

1011.2, 1011.4, 1011.5.3 (IFC [B] 1011.2, 1011.4, 1011.5.3)

Proponent: Manny Muniz, California Deputy State Fire Marshal (Ret.), representing self

Revise as follows:

1011.2 (IFC [B] 1011.2) Illumination. Exit signs shall be internally or externally illuminated. Exit signs shall be illuminated at all times.

Exceptions:

1. Tactile signs required by Section 1011.3 need not be provided with illumination.
2. When approved by the building official, exit signs are not required to be illuminated when the building is unoccupied.

1011.4 (IFC [B] 1011.4) Internally illuminated exit signs. Electrically powered, self-luminous and photoluminescent exit signs shall be listed and labeled in accordance with UL 924 and shall be installed in accordance with the manufacturer's instructions and Chapter 27. ~~Exit signs shall be illuminated at all times.~~

1011.5 (IFC [B] 1011.5) Externally illuminated exit signs. Externally illuminated exit signs shall comply with Sections 1011.5.1 through 1011.5.3.

1011.5.3 (IFC [B] 1011.5.3) Power source. ~~Exit signs shall be illuminated at all times.~~ To ensure continued illumination for a duration of not less than 90 minutes in case of primary power loss, the sign illumination means shall be connected to an emergency power system provided from storage batteries, unit equipment or an on-site generator. The installation of the emergency power system shall be in accordance with Chapter 27.

Exception: Approved exit sign illumination means that provide continuous illumination independent of external power sources for a duration of not less than 90 minutes, in case of primary power loss, are not required to be connected to an emergency electrical system.

Reason: Many buildings that are required to have exit signs illuminated 24/7 are unoccupied more than they are occupied. This wastes electricity needlessly and often shortens the life span of exit sign bulbs, thus requiring more frequent bulb replacement. Failure to maintain and replace exit sign bulbs is the number one cause of exit sign inoperability. The building official should be given the power to make determinations of when it is appropriate to have exit signs illuminated at all times and when it is not. It should be noted that 1006.1 means of egress illumination (1 foot candle) "...shall be illuminated at all times the building space served by the means of egress is occupied." Means of egress illumination and exit sign illumination should always operate together so that a person can see the egress path and then identify the exit doors. In a typical office building where workers work from 9 AM to 6 PM Monday through Friday, and allowing for the building being opened at 8 AM and closed at 7 PM, the building is occupied less than one-third of the time. Two thirds of the time, electricity consuming exit signs are serving no purpose at all.

Typical Office Building

Exit signs on when building occupied = 55 hrs/week
52 weeks = 2,860 hrs/year

Versus

Exit signs on 24/7 = 168 hrs/week
365 days per year = 8,760 hrs/year

Cost Impact: The code change proposal will not increase the cost of construction.

Public Hearing: Committee:	AS	AM	D
Assembly:	ASF	AMF	DF

ICCFILENAME:Muniz-E3-1011.4

E90–09/10

1011.2 (New) [IFC [B] 1011.2 (New)]

Proponent: Donald LeBrun, CBO, State of Indiana, Fire & Building Safety, representing Indiana Association of Building Officials

Add new text as follows:

1011.2 (IFC [B] 1022.1) Location. When exit signs are mounted on the same vertical plane as the exit or exit-access door served the sign shall be centered above the door with the bottom of the sign no more than 12 inches (305 mm) above the door leaf. Other exit signs used to direct persons to the exit or exit-access door shall be no higher than 10' feet (3.05 m) above the finish floor.

(Re-number subsequent sections)

Reason: Currently we have no direction as to where exit signs should be located. With the higher ceilings being used in more structures we are finding exit signs being mounted well above the exit served, sometimes as much as 25 feet above the door. In an emergency situation people will seek exiting information at their eye level and never see the exit sign 20 feet above their heads. Mounting exit signs at the proposed levels would greatly increase the visibility and effectiveness of the exit signs.

Cost Impact: This proposal will not increase the cost of construction

Public Hearing:	Committee:	AS	AM	D
	Assembly:	ASF	AMF	DF

ICCFILENAME:Lebrun-E1-1011.2

E91–09/10

1011.2 (New) [IFC [B] 1011.2 (New)]

Proponent: Donald LeBrun, CBO, State of Indiana, Fire & Building Safety, representing Indiana Association of Building Officials

Add new text as follows:

1011.2 (IFC [B] 1022.1) Floor-level exit signs in Group R-1. Where exit signs are required by Section 1011.1, additional low-level exit signs shall be provided in all corridors serving guest rooms in Group R-1 occupancies.

The bottom of such sign shall be not less than 6 inches (152mm) nor more than 8 inches (203mm) above the floor level. For exit and exit-access doors, the sign shall be on the door or adjacent to the door with the closest edge of the sign within 4 inches (102 mm) of the door frame.

(Re-number subsequent sections)

Reason: This proposal is specifically intended for use group R-1 occupancies where the occupants are transient and not familiar with their surroundings. The current practice of installing exit signs above the heads of most people works well except in a smoke filled space which often accompanies a fire situation. As the space fills with smoke the effectiveness of the high level exit signage diminishes forcing evacuees to crawl on the floor to reach the nearest exit. The installation of these low level will greatly assist these persons in safely exiting the structure.

Cost Impact: This proposal will increase the cost of construction

Public Hearing:	Committee:	AS	AM	D
	Assembly:	ASF	AMF	DF

ICCFILENAME:Lebrun-E2-1011.2

E92–09/10

1011.3, 1011.3.1-1011.3.8 (New) [IFC [B] 1011.3, 1011.3.1-1011.3.8 (New)]

Proponent: Dallas Dixon, representing ERR Architecture INC

Delete and substitute as follows:

1011.3 (IFC [B] 1011.3) Tactile exit signs. A tactile sign stating EXIT and complying with ICC A117.1 shall be provided adjacent to each door to an area of refuge, an exterior area for assisted rescue, an exit stairway, an exit ramp, an exit passageway and the exit discharge. Tactile signs shall be provided adjacent to exit access doors and doors leading to enclosed exits where exit signs are required by Section 1011.1. Tactile signs shall be provided adjacent to doors leading to areas of refuge and exterior areas for assisted rescue where identification signs are required by Section 1007.9. Signs shall provide information as indicated in Sections 1101.3.1 through 1101.3.8. All tactile signs shall comply with ICC A117.1 requirements for raised characters and Braille.

Exception: Where the configuration of the walls and doors will not allow for placement of the tactile signage in accordance with ICC A117.1, tactile signage in accordance with this section is not required.

1011.3.1 (IFC [B] 1011.3.1) Exit stairway. Tactile signs shall be provided adjacent to each door leading to an enclosed exit stairway stating 'EXIT STAIR'.

1011.3.2 (IFC [B] 1011.3.2) Exit access. Tactile signs shall be provided adjacent to exit access doorways stating 'EXIT ACCESS.'

1011.3.3 (IFC [B] 1011.3.3) Exit discharge. Tactile signs shall be provided adjacent to each door leading directly to an exit discharge stating 'EXIT'.

1011.3.4 (IFC [B] 1011.3.4) Exit passageway. Tactile signs shall be provided adjacent to each door leading to an exit passageway stating 'PASSAGEWAY TO EXIT'.

1011.3.5 (IFC [B] 1011.3.5) Horizontal exit. Tactile signs shall be provided adjacent to doors leading to horizontal exits stating 'EXIT TO REFUGE AREA'.

1011.3.6 (IFC [B] 1011.3.6) Exit ramps. Tactile signs shall be provided adjacent to each door or on adjacent wall leading to interior or exterior exit ramps.

1. Where an interior exit ramp is located at an exit access or an exit, signage shall state 'INTERIOR EXIT RAMP'.
2. Where an exterior exit ramp is provided, signage shall state 'EXTERIOR EXIT RAMP'

1011.3.7 (IFC [B] 1011.3.7) Exit discharge with Exterior steps. In addition to signage required by Section 1011.3.3, if the exit discharge includes a step down or stairs, tactile signs shall be provided adjacent to the exit door and:

1. Where there is a step down as permitted in Sections 1008.1.5, signage shall state 'STEP DOWN.'
2. Where the exit door landing leads to stairs, signage shall state 'OUTSIDE STAIRS'.

1011.3.8 (IFC [B] 1011.3.8) Area of refuge. Where identification signage is required by Section 1007.9, tactile signage shall be provided at the following locations:

1. Where an area of refuge is located in an elevator lobby, tactile signs shall be provided on all doors leading to the elevator lobby stating 'AREA OF REFUGE'.
2. Where an area of refuge is located inside an exit stairway enclosure, in addition to the sign required by Section 1011.3.1, a tactile sign shall be provided adjacent to the door leading to the stairway stating 'AREA OF REFUGE'.
3. Where an area of refuge is located adjacent to an exit stairway enclosure, in addition to the sign required by Section 1011.3.2, a tactile sign shall be provided adjacent to the door leading to the area of refuge stating 'AREA OF REFUGE.'
4. Where an exterior area for assisted rescue is provided, in addition to the sign required by Sections 1011.3.3 and 1011.3.7, a tactile sign shall be provided adjacent to the exterior door stating 'EXTERIOR AREA FOR ASSISTED RESCUE.'

Reason: The intent of this proposal is to provide clarity where tactile exit signage should be provided. In addition, specific text will help direct persons with vision impairments to a safe path out of the building or to an area of rescue assistance. For example, letting someone with visual impairments know that they will be dealing with steps or ramps when they walk through a door, will provide for safer paths.

With the advent of the Big Box buildings and mega size multi-use building, the requirements for Tactile Signage as addressed in Section 1011.3 does not provide enough specifics or clarity. The exceptions of Section 1011.1 further provide confusion for where tactile signs shall be required and where are they exempted. Section 1011.3 generically addresses the placement of tactile signs adjacent to doors leading to an area of refuge, an area of assisted rescue, an exit stairway, an exit ramp, an exit passageway and exit discharge.

Tactile signage is not required where exit signs are not required so it will be manageable for code officials and fire officials to identify appropriate locations. The intent of the exception to Section 1011.3 is to address situations where there is no practical place to locate such signage so it can be found by a person with visual impairments (i.e., open stairways, horizontal sliding doors, storefront arrangement with glass doors and side lights, multiple doors together like at a main assembly space exit).

Current code does not address tactile signage requirement for exiting through horizontal exits or specific requirement and information when areas of refuge and exterior areas of rescue assistance are required. This code change includes text that specifically addresses these areas with regard to tactile signage

Cost Impact: This code change proposal will not increase the cost of construction

Public Hearing: Committee: AS AM D
Assembly: ASF AMF DF

ICCFILENAME: DIXON-E1-1011.3

E93–09/10

1011.6 (New) [IFC [B] 1011.6 (New); IFC 1030.4.1

Proponent: Joshua D. Smith, Fire Protection Specialist, representing New York State Department of State – Office of Fire Prevention and Control

THIS IS A 2 PART CODE CHANGE. BOTH PARTS WILL BE HEARD BY THE IBC MEANS OF EGRESS CODE COMMITTEE AS 2 SEPARATE CODE CHANGES. SEE THE TENTATIVE HEARING ORDER FOR THIS COMMITTEE.

PART I – IBC MEANS OF EGRESS

Add new text as follows:

1011.6 (IFC [B] 1011.6) Door Mounted Exit Signs. For Groups A, B, E, I, M, and R-1 occupancies, all exit and exit access doors required to have exit signs in accordance with Section 1011.1 shall, in addition, be marked on the door with a self-luminous or photoluminescent exit sign. The bottom of the sign shall not be less than 6 inches above the floor and not more than 18 inches above the floor. The sign shall be permitted to be made of any material, including paint, provided that an electrical charge is not required to maintain the required luminance. Such materials shall include, but are not limited to, self-luminous materials and photoluminescent materials in accordance with Section 1024.4

PART II – IFC

Add new text as follows:

1030.4.1 Door Mounted Exit Signs. For Groups A, B, E, I, M, and R-1 occupancies, all exit and exit access doors required to have exit signs in accordance with Section 1011.1 shall, in addition, be marked on the door with a self-luminous or photoluminescent exit sign. The bottom of the sign shall not be less than 6 inches above the floor and not more than 18 inches above the floor. The sign shall be permitted to be made of any material, including paint, provided that an electrical charge is not required to maintain the required luminance. Such materials shall include, but are not limited to, self-luminous materials and photoluminescent materials in accordance with Section 1024.4

Reason: The current requirements for exit signs have them being hung from the ceiling or mounted high up on a wall. In the event of a fire as a room or corridor is filling with smoke, the exit signs and emergency lighting can quickly become obscured. As building occupants and/or fire fighters are moving through the building with obscured exit signs, determining the difference between an exit door from any other door can become complicated if not impossible at times. Having the floor proximity exit signs mounted on the doors will still provide a marked means of egress when other exit signs are no longer visible. NFPA 101 also has provisions for these signs.

Cost Impact: The code change proposal will increase the cost of construction

PART I – IBC MEANS OF EGRESS

Public Hearing: Committee: AS AM D
Assembly: ASF AMF DF

PART II – IFC

Public Hearing: Committee: AS AM D
Assembly: ASF AMF DF

E94–09/10
1012.2 (IFC [B] 1012.2)

Proponent: Kenneth F. Traugott, NVR, Inc, representing self

Revise as follows:

1012.2 (IFC [B] 1012.2) Height. Handrail height, measured above stair tread nosings, or finish surface of ramp slope shall be uniform, not less than 34 inches (864 mm) and not more than 38 inches (965 mm). Handrail height of alternating tread devices and ship ladders, measured above tread nosings, shall be uniform, not less than 30 inches (762 mm) and not more than 34 inches (864mm).

Exception: When handrail fittings or bendings are used to provide continuous transition between flights, transition at winder treads, transition from handrail to guard, or when used at the start of a flight, the handrail height at the fittings or bendings shall be permitted to exceed the maximum height.

Reason: The above information is being requested to clarify the Code. Fittings such as easings and gooseneck risers are commonly used features intended to provide rail continuity at locations where a straight transition is not possible. Incorporating such features is consistent with the provisions of IBC Section 1012.4 (Continuity) and with standard architectural and construction practice.

The intent of the Code is that the provisions of 1012.3 be applied only over the stair run, and not at landings. The handrail height requirements are applicable over the stairway run, not at landings. The height of the handrail, when it doglegs or u-turns over a landing, will vary so that the handrail can remain continuous in accordance with Section 1012.4 and 1012.5. The handrail extensions at the end must also meet the protruding object provisions if they return to a support post (Section 1003.3.2 and 1012.5).

Unfortunately, the current wording of the Code, although it does indicate that height requirements should be “measured above stair tread nosings,” does not clearly state that the height requirements do not apply over landings, at winder treads, where handrails meet a guardrail, or when used at the start of a flight. Inspectors, plan reviewers, and other building code officials in many jurisdictions are currently not accepting handrail fittings such as easings or gooseneck risers.

Cost Impact: The code change proposal will not increase the cost of construction.

Public Hearing: Committee:	AS	AM	D
Assembly:	ASF	AMF	DF

ICCFILENAME: TRAUGOTT-E1-1012.2

E95–09/10
1012.2 (IFC [B] 1012.2)

Proponent: Kenneth F. Traugott, NVR, Inc, representing self

Revise as follows:

1012.2 (IFC [B] 1012.2) Height. Handrail height, measured above stair tread nosings, or finish surface of ramp slope shall be uniform, not less than 34 inches (864 mm) and not more than 38 inches (965 mm). Handrail height of alternating tread devices and ship ladders, measured above tread nosings, shall be uniform, not less than 30 inches (762 mm) and not more than 34 inches (864 mm).

Exception: In Group R-3 occupancies; within dwelling units in Group R-2 occupancies; and in Group U occupancies that are associated with a Group R-3 occupancy or associated with individual dwelling units in Group R-2 occupancies; when handrail fittings or bendings are used to provide continuous transition between flights, transition at winder treads, transition from handrail to guard, or when used at the start of a flight, the handrail height at the fittings or bendings shall be permitted to exceed the maximum height.

Reason: The above information is being requested to clarify the Code. Fittings such as easings and gooseneck risers are commonly used features intended to provide rail continuity at locations where a straight transition is not possible. Incorporating such features is consistent with the provisions of IBC Section 1012.4 (Continuity) and with standard architectural and construction practice.

The intent of the Code is that the provisions of Section 1012.3 be applied only over the stair run, and not at landings. The handrail height requirements are applicable over the stairway run, not at landings. The height of the handrail, when it doglegs or u-turns over a landing, will vary so that the handrail can remain continuous in accordance with Section 1012.4 and 1012.5. The handrail extensions at the end must also meet the protruding object provisions if they return to a support post (Section 1003.3.2 and 1012.5).

Unfortunately, the current wording of the Code, although it does indicate that height requirements should be “measured above stair tread nosings,” does not clearly state that the height requirements do not apply over landings, at winder treads, where handrails meet a guardrail, or when used at the start of a flight. Inspectors, plan reviewers, and other building code officials in many jurisdictions are currently not accepting handrail fittings such as easings or gooseneck risers which are provided to maintain continuity.

This would be consistent with the provisions in the International Residential Code, Section R311.7.7.1, Exp. 2.

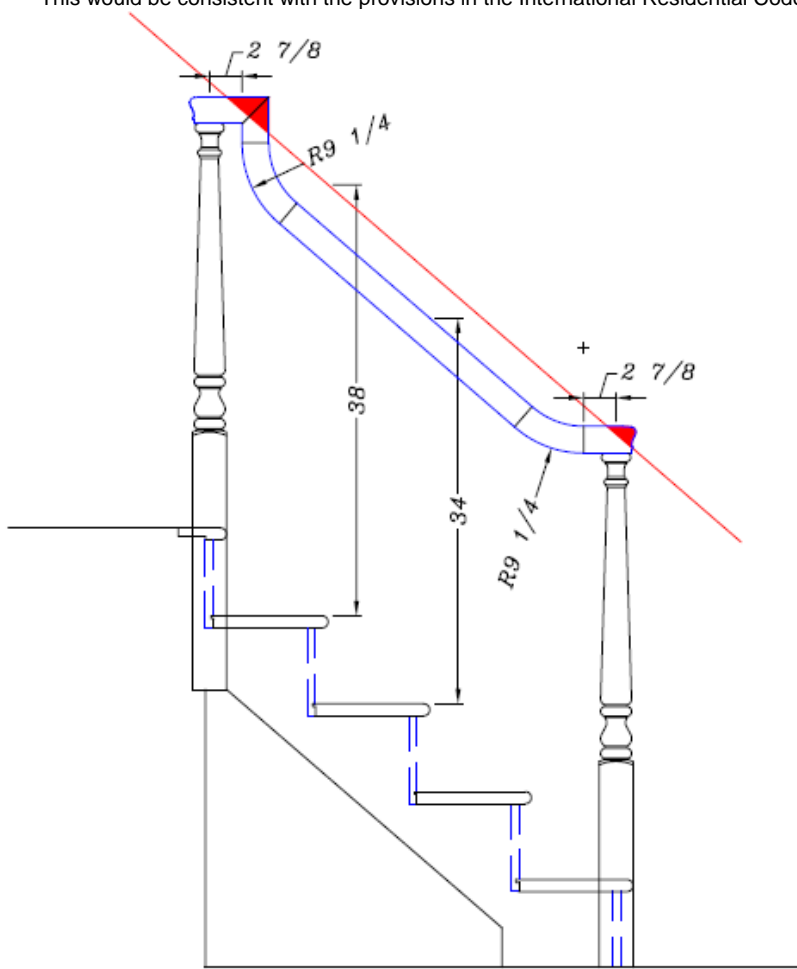

Cost Impact: The code change proposal will not increase the cost of construction.

Public Hearing:	Committee:	AS	AM	D
	Assembly:	ASF	AMF	DF

ICCFILENAME: TRAUGOTT-E2-1012.2

E96-09/10

1012.3 (IFC [B] 1012.3)

Proponent: David W. Cooper, Stair Manufacturing and Design Consultants, representing the Stairway Manufacturers' Association, Inc.

Revise as follows:

1012.3 (IFC [B] 1012.3) Handrail graspability. At ramps that serve as a portion of an accessible route required by Chapter 11, handrails shall comply with Section 1012.3.1 or shall provide equivalent graspability. All other required handrails shall comply with Section 1012.3.1 or 1012.3.2 or shall provide equivalent graspability.

~~**Exception:** In Group R-3 occupancies; within dwelling units in Group R-2 occupancies; and in Group U occupancies that are accessory to a Group R-3 occupancy or accessory to individual dwelling units in Group R-2 occupancies; handrails shall be Type I, Type II as follows or shall provide equivalent graspability.~~

1012.3.1 Type I. Handrails with a circular cross section shall have an outside diameter of at least 1 ¼ inches (32 mm) and not greater than 2 inches (51 mm). If the handrail is not circular, it shall have a perimeter dimension of at least 4 inches (102 mm) and not greater than 6 ¼ inches (160 mm) with a maximum cross-section dimension of 2 ¼ inches (57 mm). Edges shall have a minimum radius of 0.01 inch (0.25 mm).

1012.3.2 Type II. Handrails with a perimeter greater than 6 ¼ inches (160 mm) shall provide a graspable finger recess area on both sides of the profile. The finger recess shall begin within a distance of ¾ inch (19 mm) measured vertically from the tallest portion of the profile and achieve a depth of at least 5/16 inch (8 mm) within 7/8 inch (22 mm) below the widest portion of the profile. This required depth shall continue for at least 3/8 inch (10 mm) to a level that is not less than 1 ¾ inches (45 mm) below the tallest portion of the profile. The minimum width of the handrail above the recess shall be 1 ¼ inches (32 mm) to a maximum of 2 ¾ inches (70 mm). Edges shall have a minimum radius of 0.01 inch (0.25 mm).

Reason: This proposal identifies additional applications of the use of Type II handrails only in those areas that are not part of an accessible route. The A117.1 standard is not referenced for stairways or their handrails. This provision will clarify that other options are and should be available for advantageous and safe use of all.

Understanding the Options:

Type II Handrails provide many advantageous options recognized in the ICC's acceptance within both the IRC and IBC. Among these of course is regulated design freedom controlled by a standard that will provide rails with known performance equivalent to or exceeding the performance of the minimum standard accepted for type I rails.

Type II Handrails cannot be any shape but are precisely controlled by the code text to provide graspable recesses within the grasp of all.

Type I rails may be any shape, regardless of practicality, provided the perimeter and cross section dimension is met. Lacking specific criteria the handrails may only be designed for hand size specific applications, i.e. small perimeters for smaller hands, larger perimeters for larger hands.

The Type II handrail code language provides a recognized value in describing the best way in which to design handrail shapes other than round and thereby improves the code.

Type II Handrails are not impeded by obstructions to the bottom of the rail. They allow for more versatile installations using brackets or balusters attached to the bottom for support without compromising the graspable surface. Especially in the event of a fall the Type II handrail grasping surface is readily available without interference from supports. In fact its grasping surface is the same as its guidance and stabilizing surface and a continuous grasp is possible without interruption. The user does not need to change the position of the hands and fingers to achieve a stabilizing or fall arresting grasp but only increase the tightness of the grip. In the real world of handrail use this kind of practicality also aids those that need to pull themselves with the benefit of maintaining a controlled continuous grip without the need to release the handrail.

Type I rails require access to the bottom surface of the rail and the formation of a full finger wrap grip in order to exert forces comparable to Type II handrails with required recesses. In the event of a fall the purchase point of a grip is random unlike common type I rail uses where it may only be possible for the user to choose the available purchase points they can see or simply run their fingers on the top or side of the rail. Brackets or balusters are allowed to block up to 20% of the grasping surface in some codes and could easily diminish the effective use of the type I rail in a fall by a similar factor or more in reducing the probability of arresting a fall especially when compared to Type II handrails where a constant continuously safe grip, in the ready state, can be maintained. The extent of this very real detriment of type I rail, although recognized, may be impossible to determine.

Research and Testing Advances Since Previous Proposal in Rochester:

Since the addition of Type II handrails in the IBC in 2007 at the Rochester final action hearings significant advancements have been made. As requested in opposing testimony **Peer review and publication of the research** and also **testing of persons with disabilities**, has been done. These were the reasons for approval of the adoption of Type II handrails in the IBC only for residential applications. I am pleased to report that both these issues have been addressed.

SMA Funded Research Published in Peer Reviewed Journal:

The substantial research and testing funded by the Stairway Manufacturers' Association supporting the adoption of Type II handrails has been peer reviewed, accepted for publication, and published in the July 2009 edition of Applied Ergonomics a highly respected peer review journal. This lengthy and rigorous review process of more than two-years was initiated prior to the Rochester hearing at the request of the A117.1 committee. The paper title and reference are:

"Effect of handrail shape on graspability"; Donald O. Dusenberry, Howard Simpson, Steven J. DelloRusso;
Applied Ergonomics, Volume 40 (2009), issue 4, pp.657-669.

The paper has been published electronically for comment by the scientific community since June 2008. The author's pre-print manuscript can be downloaded at <http://www.sgh.com/pdf/Effect-of-Handrail-Shape-on-Graspability.pdf>. At the time of this submission more than a year has passed and no comments have been received by the author, Applied Ergonomics, or through the on-line scientific collaborative.

Handrail Shape Testing of Persons with Disabilities Funded by SMA

Of additional consequence are the first tests of persons with disabilities related to the shape of handrails in use on stairs and ramps. Three handrail profiles (shown below) were tested by persons in 4 categories of mobility impairments while using stairs and ramps. These tests were performed at PARQUAD a state of the art assisted living facility in St. Louis, MO, where research related to mobility impairments is done on a regular basis. The tests were performed by **Dr. David B. Gray** a noted researcher from Washington University also in St. Louis. Each of the 28 participants was videotaped in their use of handrails as they ascended and descended stairs and ramps. The complete report of the study and excerpts from the many hours of video are available at http://www.stairways.org/code_changes/A117%20Binder%20SMA%20Presentation%20090105.pdf. The study was completed on the eve of the January 5, 2009 meeting of the A117 Committee. Although the committee had requested testing of persons with disabilities related to handrail shape in testimony, ballot comment, and in committee reason statements the January meeting schedule was reduced from 2 days to 1 day and only a brief 20 minute summary of the research and the proposal was allowed making the review of any of the video content not possible. At the time of this submission the SMA has filed an appeal with the secretariat in an attempt to have the opportunity to make a detailed presentation of the study and video recordings with in the 2008 cycle of the standard. We would encourage you to read the full study. While further work with larger samples was suggested to provide enough data to analyze for comparison of data between sample groups, some of the findings are summarized here:

All shapes were rated good to excellent and reported to be of assistance
Wheelchair users preferred the Type I profile, HR1 shape (reported use only while ascending ramps).

All other participants preferred the larger Type II, HR3 handrail. (on left below)

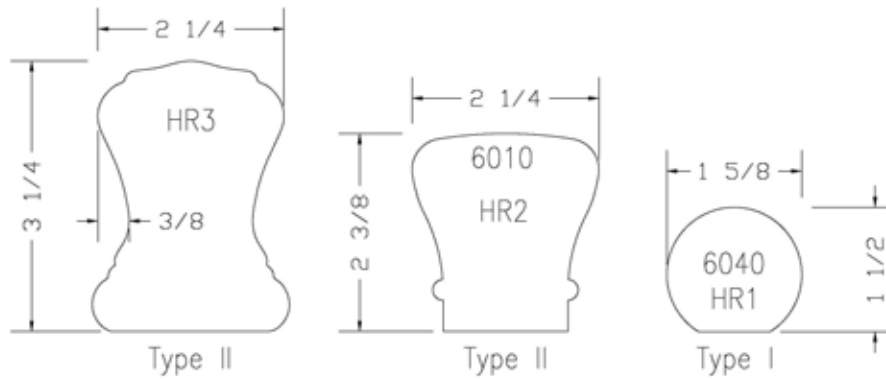

Other Facts:

This proposal identifies suitable application of the use of type II rails only in those areas that are not part of an accessible route. The A117.1 standard is not referenced by the means of egress code for stairways because stairs are not part of an accessible route. This provision will help to clarify that other options are and should be available for advantageous and safe use by all. Conflict with the accessibility provisions of Chapter 11 and the A117.1 standard referenced there is eliminated by the text that requires use of Type I rails at ramps, which are a part of an accessible route.

No stairway is part of an accessible route.

It is important to understand that this change only provides the optional use of the scientifically proven, peer reviewed, Type II alternative but does not eliminate the option to use type I rails. This proposal does not create any conflict with the referenced application of the A117.1 Standard.

This option will reduce the cost of construction by allowing materials and fabrication methods in the development of handrail and related guard products now restricted by the code. This will be best illustrated by the use of larger section handrails with necessary strength properties in wood, plastic, and lighter metals may be included with other options currently available and easily fabricated in the field.

Cost Impact: The code change proposal will not increase the cost of construction.

Public Hearing: Committee:	AS	AM	D
Assembly:	ASF	AMF	DF

ICCFILENAME: Cooper-E2-1012.3

E97-09/10

1012.3, 1012.3.1, 1012.3.2 (IFC [B] 1012.3, 1012.3.1, 1012.3.2); IRC R311.7.7.3

Proponent: Jake Pauls, representing self

THIS IS A 2 PART CODE CHANGE. PART I WILL BE HEARD BY THE IBC MEANS OF EGRESS. PART II WILL BE HEARD BY THE IRC BUILDING/ENERGY COMMITTEE. SEE THE TENTATIVE HEARING ORDERS FOR THESE COMMITTEES.

PART I – IBC MEANS OF EGRESS

Revise as follows:

1012.3 (IFC [B] 1012.3) Handrail graspability. All required handrails shall comply with Section 1012.3.1 or shall provide equivalent graspability.

Exception: In Group R-3 occupancies; within dwelling units in Group R-2 occupancies; and in Group U occupancies that are accessory to a Group R-3 occupancy or accessory to individual dwelling units in Group R-2 occupancies; handrails shall be Type I in accordance with Section 1012.3.1, Type II in accordance with Section 1012.3.2 or shall provide equivalent graspability.

1012.3.1 (IFC [B] 1012.3.1) Type I. Handrails with a circular cross section shall have an outside diameter of at least 1 ¼ inches (32 mm) and not greater than 2 inches (51 mm) or shall provide equivalent graspability. If the handrail is not circular, it shall have a perimeter dimension of at least 4 inches (102 mm) and not greater than 6 ¼ inches (160 mm) with a maximum cross-section dimension of 2 ¼ inches (57 mm). Edges shall have a minimum radius of 0.125 inch (3 mm).

1012.3.2 (IFC [B] 1012.3.2) Type II. Handrails with a perimeter greater than 6 ¼ inches (160 mm) shall provide a graspable finger recess area on both sides of the profile. The finger recess shall begin within a distance of ¼ inch (19 mm) measured vertically from the tallest portion of the profile and achieve a depth of at least 5/16 inch (8 mm) within 7/8 inch (22 mm) below the widest portion of the profile. This required depth shall continue for at least 3/8 inch (10 mm) to a

level that is not less than 1 ¾ inches (45 mm) below the tallest portion of the profile. The minimum width of the handrail above the recess shall be 1 ¼ inches (32 mm) to a maximum of 2 ¾ inches (70 mm). Edges shall have a minimum radius of 0.01 inch (0.25 mm).

PART II – IRC BUILDING/ENERGY

R311.7.7.3 Graspability Grip-size. All required handrails shall be of one of the following types or provide equivalent graspability.

1. ~~Type I. Handrails with~~ have a circular cross section shall have an outside diameter of at least 1 ¼ inches (32 mm) and not greater than 2 inches (51 mm) or shall provide equivalent graspability. If the handrail is not circular, it shall have a perimeter dimension of at least 4 inches (102 mm) and not greater than 6 ¼ inches (160 mm) with a maximum cross section of dimension of 2 ¼ inches (57 mm). Edges shall have a minimum radius of 0.12 ~~0.01~~ inch (3 mm ~~0.25~~ mm).
2. ~~Type II. Handrails with a perimeter greater than 6 ¼ inches (160 mm) shall provide a graspable finger recess area on both sides of the profile. The finger recess shall begin within a distance of ¾ inch (19 mm) measured vertically from the tallest portion of the profile and achieve a depth of at least 5/16 inch (8 mm) within 7/8 inch (22 mm) below the widest portion of the profile. This required depth shall continue for at least 3/8 inch (10 mm) to a level that is not less than 1 ¾ inches (45 mm) below the tallest portion of the profile. The minimum width of the handrail above the recess shall be 1 ¼ inches (32 mm) to a maximum of 2 ¾ inches (70 mm). Edges shall have a minimum radius of 0.01 inch (0.25 mm).~~

Reason: Over the last decade or so there has been much discussion about the research that the Stairway Manufacturers Association (SMA) has funded on handrail graspability. There have been a few conference papers produced specifically on the Type II handrails testing in comparison with the 2-inch round handrail, the largest circular shape permitted under the codes and standards. Identified as Dusenberry and Simpson (1996) and Dusenberry et al. (1999), these lacked detail and were impossible to assess scientifically. The only peer-reviewed, mainstream journal article for which SMA provided research support—but had to let its author, Dr. Brian Maki publish without restriction from SMA—had the appropriate detail and made a great contribution to the field of handrail performance. SMA is congratulated for funding Maki's work but, in saying this, I betray a bit of bias here as I funded Maki's work from my research management position at the National Research Council of Canada in the 1980s.

The SMA-funded work on the Type II handrails was different and thus there was much anticipation of it finally being published in a mainstream, peer-reviewed journal, Applied Ergonomics. While not one of the peer reviewers, I had access to the paper in draft and preprint form through my membership on the A117 Committee on for the ICC/ANSI standard, A117.1, Accessible and Usable Buildings and Facilities (with ICC as its secretariat). SMA's representative on this Committee wanted to have Type II handrails permitted in that standard, especially after SMA efforts to get Type II handrails into the IBC for non-dwelling stairways were blocked by some arguing that the mainstreamed Type II handrails should at least be acceptable to the A117 Committee. As the draft paper worked its way through the Applied Ergonomics review and publication process, it was unclear how the A117 Committee would finally come down on its acceptability for the ICC/ANSI A117.1 standard. There were clear misgivings by many on the Committee about the functionality of such handrails which severely constrained the potential graspability of users and did not permit fingers to wrap around the handrail from any approach direction.

Finally, when the preprint was made available by the publisher, it was finally possible to see exactly what had survived Applied Ergonomics peer review process which, to Dr. Maki and myself, appeared to miss identifying and correcting some serious weaknesses in the study design, execution and reporting. In our view the paper was not suitable for publication in the form we saw. Finally, in January 2009—over a decade since the first, clearly superficial publication of the SMA work (other than the work written up by Dr. Maki)—it finally became clear that there were far deeper problems with SMA's work (other than Maki's). Stated as simply and directly as possible, the early papers glossed over exactly what was done and what the results were to the point that it was not evident that the Type II handrails being tested were not the ones that were being sold in the handrail marketplace. Figure 1, which has now (as of the July 2009 issue has appeared in final print form in Applied Ergonomics) shows what was tested.

Figure 1. Railing Sections Tested by SMA

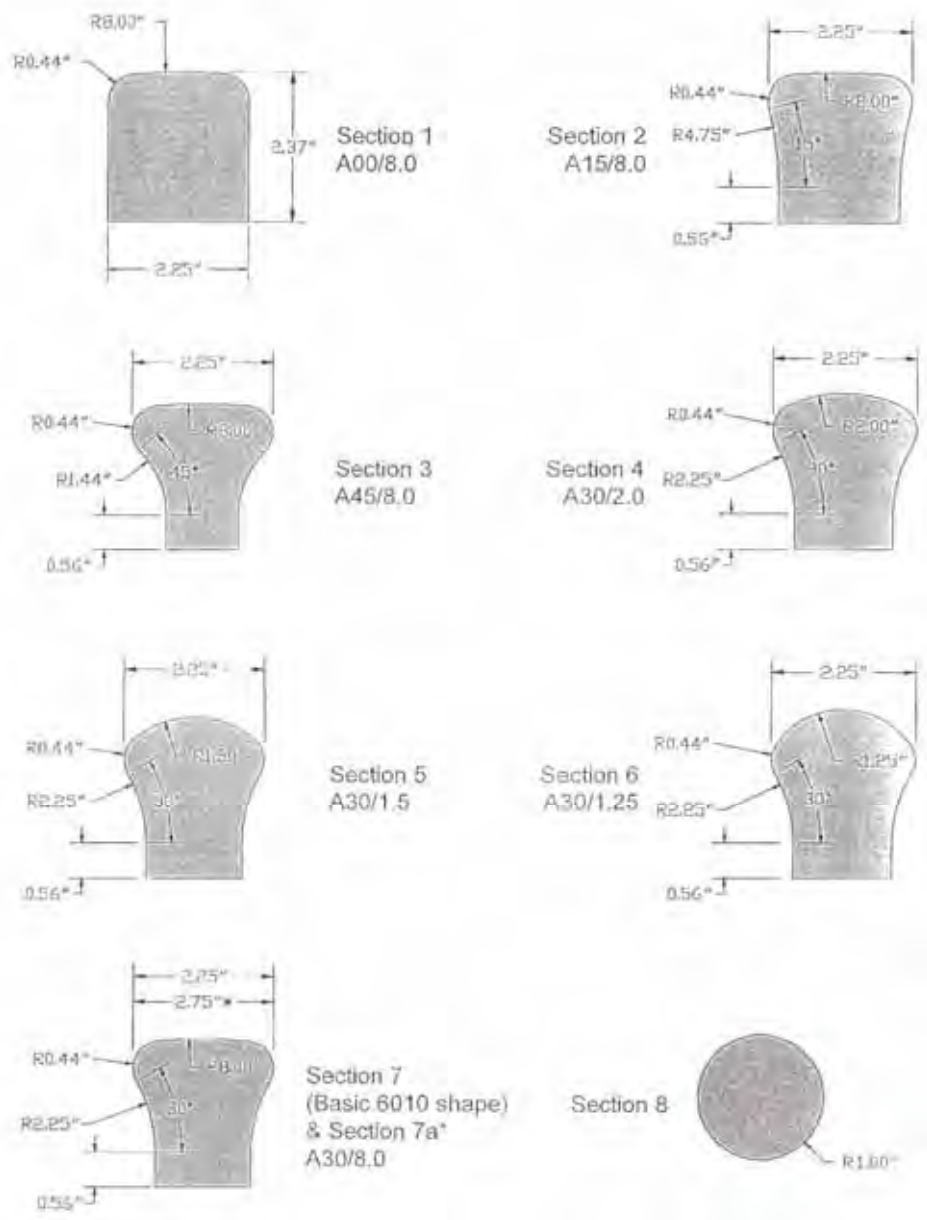
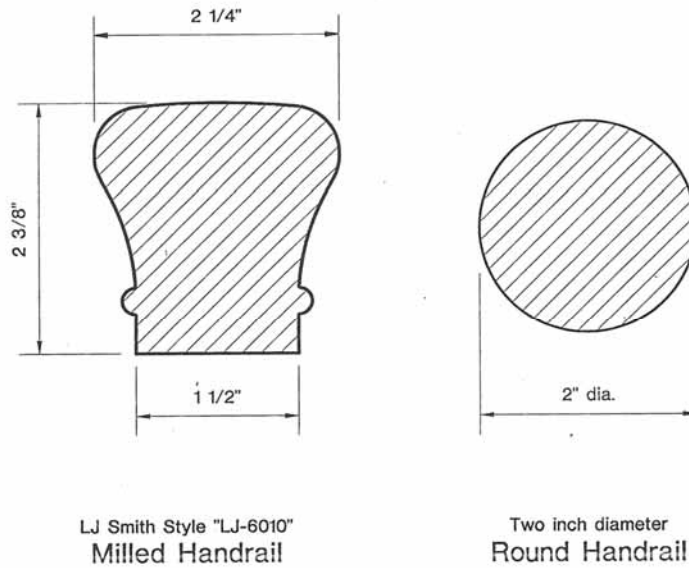

Figure 2 shows the most commonly used Type II handrail. Notably, unlike all of the sections tested (at least as described in the now authoritative Applied Ergonomics paper), the marked Type II handrail, specifically the “6010” designation, had prominent ridges near the bottom of the sides. Figure 2 shows the “6010” Type II rail next to the 2-inch round rail. In effect, SMA compared the worst (or one of the worst) of the standards/codes complying “Type I” handrail with one of the best if not the best of the Type II handrails.

Figure 2. “6010 “ Handrail—a Very Commonly Marketed and Installed section (on dwelling unit stairs especially)—and a 2-inch Round Handrail. (Notably, this was not a figure in the Applied Ergonomics paper which only shows sections and testing procedures without the ridges.)

Cross Sections of Handrail Shapes
 used in tests performed by Simpson Gumpertz and Heger Inc.
 during March and April of 1995



So there appears to be a kind of “bait and switch” here. The Type II handrails tested were consistent with the handrails sold and installed. But there are other problems that occupied me (and perhaps Dr. Maki) in reviewing the final preprint in comparison with the results we had dribbled out in public form in earlier publications in the 1990s—and the technical basis for all of the code changes that I am now trying to reverse by eliminating Type II handrails from the IRC and IBC. Figure 3 shows the early version of some test results that were purported to show superiority of the Type II handrail—or, at a minimum, at least equivalency—in comparison to the 2-inch round, again, one of the worst of the Type I handrails. Compare Figure 3 with the finally published figure which, for the first time, shows the actual data points and reveals that the round handrail performed about twice as well as the Type II (designation “6010”) without its ridges.

Figure 3. Early Published Comparison of Type II Performance with 2-inch Round Performance.

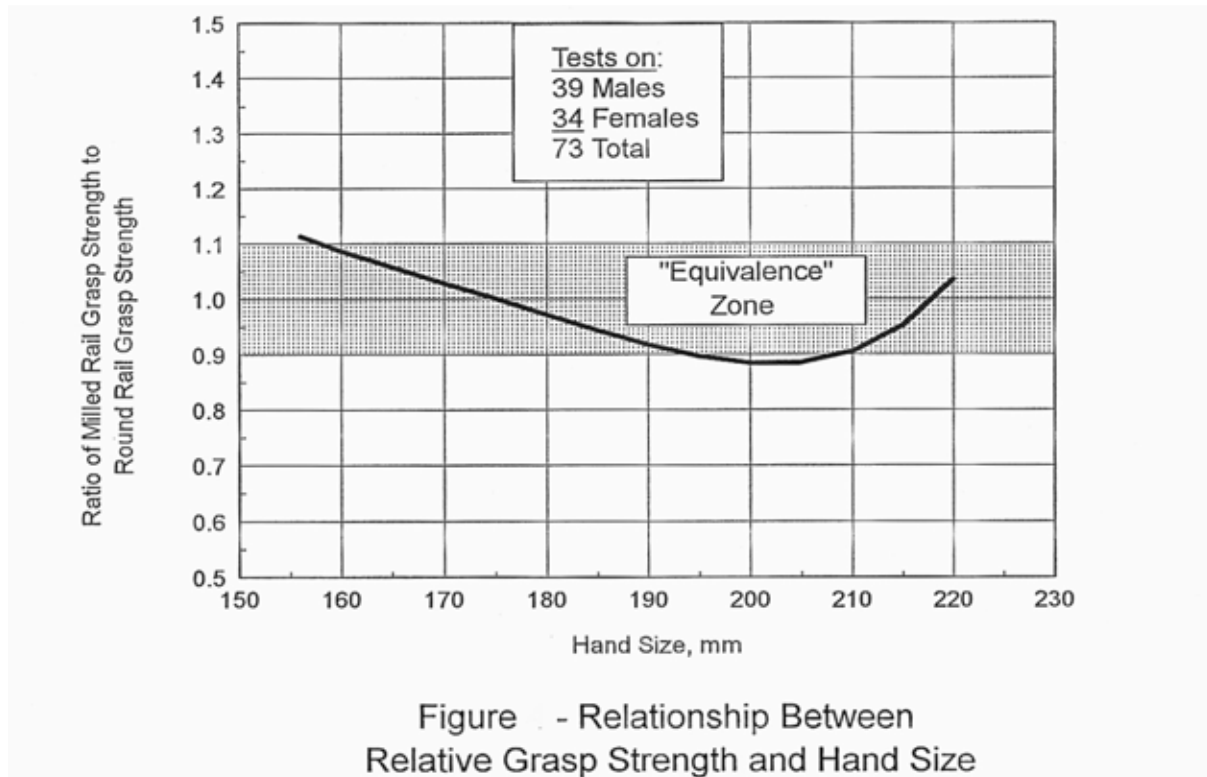

Figure 4. Finally Published Data (Figure 6 in the Applied Ergonomics Paper) that Should have been Presented in Figure 3 Years Earlier

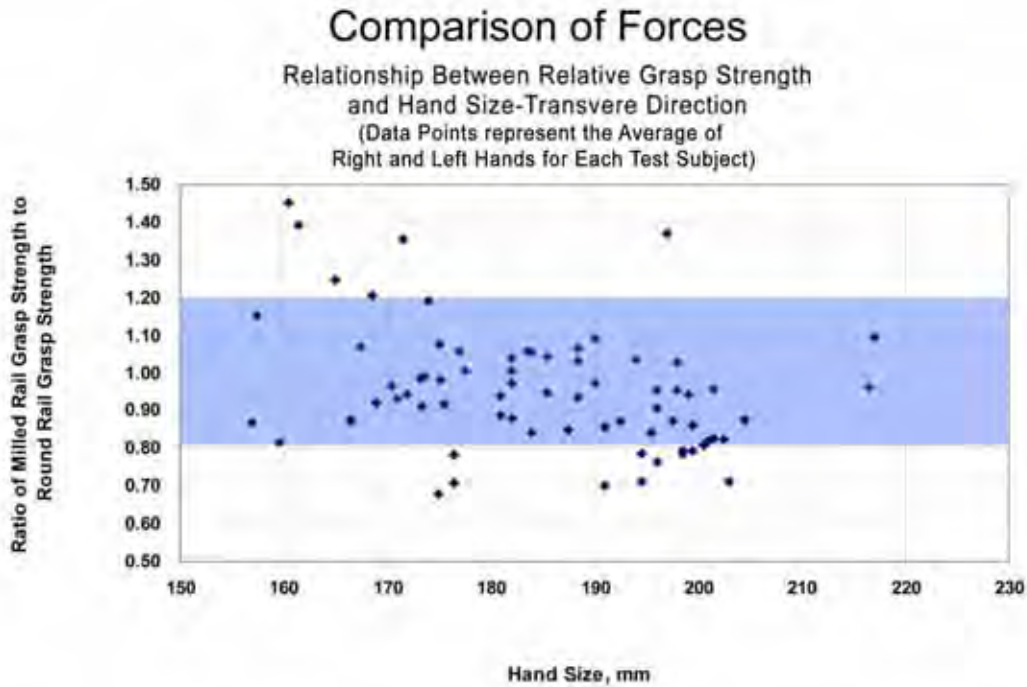
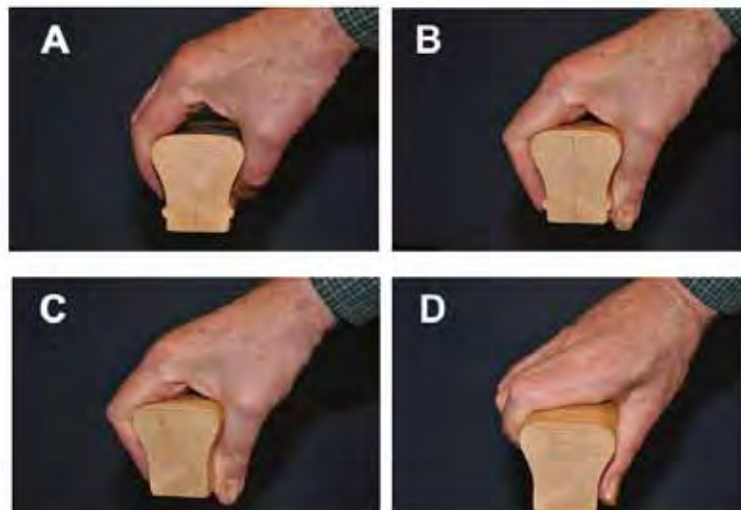

Figure 6- Phase I Graspability Test Results - Comparison of 51-mm Diameter Round Rail and Basic 6010 Milled Shape.

Finally, what is the potential role played by the ridges that, apparently, were conveniently left off the tested sample sections (if we are to believe the Applied Ergonomics paper)?

The remaining figures illustrate the awkward pressure points these ridges cause in various attempts to gain the one type of grip permitted by the Type II rails, a pinch grip (as opposed to the power grip afforded by Type I handrails). Clearly, in my professional opinion, Type II handrails are not superior or even equivalent to Type I handrails, even without the annoying and painful ridges when attempting to get a pinch grip, such as it is.

Figure 5 A, B, C and D (top left, top right, bottom left, bottom right). Examples of Various Attempts to Grasp a “6010” Designation, Type II Handrail and a “6010” with Its Ridges Taken Off.



Experiencing the pressure points from the ridges is painful. Experiencing the same rail without the ridges is frustrating, albeit not as painful. Neither is an appropriate handrail in a safety-oriented code or within a national standard focused on usability.

With the publication of the Applied Ergonomics paper, it is time to clear up exactly what we bought when the Type II handrails were incorporated in the IRC and to a limited extent in the IBC. They do not belong in either with their very dubious justification that we have gotten over the last decade or so. Soon perhaps, there will be the first court case after publication of the Applied Ergonomics paper. It will be interesting to see

how the courts, and the litigation process generally, handle the technical evidence in comparison to how it was handled in the ICC process. (NFPA has stayed clear of Type II handrails.)

Bibliography

Dusenberry, D.O. and Simpson, H. (1996). Handrail graspability. *Proceedings of 11th Conference, Engineering Mechanics Division, American Society of Civil Engineers*, May 19-22, pp. 466-469. (www.pubs.asce.org/WWWdisplaybn.cgi?0784401721)
Dusenberry, D.O., Simpson, H., DelloRusso, S.J., and Rao, R.S. (1999). Evaluation of Graspability of Handrails During Falls on Stairs, *Proceedings of the 13th Conference of Engineering Mechanics, Baltimore, MD, 13-16, June, 1999*.
Donald O. Dusenberry, Howard Simpson, Steven J. DelloRusso (2009). Effect of handrail shape on graspability. *Applied Ergonomics*, 40(4) 657-669.

Cost Impact: The code change proposal will not increase the cost of construction. Easily grasped handrails are typically less costly than are the "Type II" handrails.

PART I – IBC MEANS OF EGRESS

Public Hearing:	Committee:	AS	AM	D
	Assembly:	ASF	AMF	DF

PART II – IRC BUILDING/ENERGY

Public Hearing:	Committee:	AS	AM	D
	Assembly:	ASF	AMF	DF

ICCFILENAME: Pauls-E5-1012.3

E98–09/10

1012.3.1 (IFC [B] 1012.3.1)

Proponent: Homer Maiel, PE, CBO, City of San Jose, representing ICC Tri-Chapter (Peninsula, East Bay, Monterey Bay)

Revise as follows:

1012.3.1 (IFC [B] 1012.3.1) Type I. *Handrails* with a circular cross-section shall have an outside diameter of at least 1-1/4 inches (32 mm) and not greater than 2 inches (51 mm). If the *handrail* is not circular, it shall have a perimeter dimension of at least 4 inches (102 mm) and not greater than 6-1/4 inches (160 mm) with a maximum cross-section dimension of 2-1/4 inches (57mm) and minimum cross-section dimension of 1 inch (25 mm). Edges shall have a minimum radius of 0.01 inch (0.25 mm).

Reason: The type I profile has no minimum cross sectional dimension. It needs a minimum dimension to assure graspability. The human hand gets its most secure grip on a Type I cross section that is round and smooth and allows the hand to fit comfortably around it. A handrail shape such as a 3/8" x 2" steel flat bar meets both the minimum perimeter and maximum cross section dimensions of Type I, but results in a less secure grip because it requires a pinching grasp. Try doing a chin up or pull up on a 1-1/2" diameter tube versus a 3/8" x 2" steel bar having the 2 inch dimension oriented vertically. The tube is more comfortable because a flat steel bar does not accommodate the natural curvature of a grasping hand as readily. Even with the required 1/100 of an inch radius at the corners, the flat bar is likely to be painful when applying a firm grip. When falling on a stairway, the handrail becomes the only means to steady or support oneself. For this reason, all handrails should have a shape that is comfortable and accommodating of the human hand's natural grasping shape. The proposed 1 inch minimum cross section was selected to allow use of the maximum 2" cross section in the perpendicular cross section axis and not exceed the maximum allowed 6-1/4" total perimeter.

Cost Impact: The code change proposal will not increase the cost of construction.

Public Hearing:	Committee:	AS	AM	D
	Assembly:	ASF	AMF	DF

ICCFILENAME: Maiel-E5-1012.3

E99–09/10

1012.8 (IFC [B] 1012.8)

Proponent: Gene Boecker, Code Consultants, Inc., representing Code Consultants, Inc.

Revise as follows:

1012.8 (IFC [B] 1012.8) Projections. On ramps, the clear width between handrails shall be 36 inches (914 mm) minimum. Projections into the required width of stairways and ramps at each handrail side shall not exceed 4 1/2 inches (114 mm) at or below the handrail height. Projections into the required width shall not be limited above the minimum

headroom height required in Section 1009.2. Projections due to intermediate handrails shall not constitute a reduction in the egress width.

Reason: There are two changes in this proposal. First, the second sentence is being reworded to address the actual condition – the side of the ramp or stairway. It is not just the handrail that is the issue; it could be the stringer to the stairway or the edge protection detail for the ramp. Both of these are located at the side. The word “handrail” is extraneous.

Second, there is currently no direction on whether or not the intermediate handrail, required by Section 1012.9 creates a projection or reduces the egress width of the stairway or ramp (if provided). The sentence makes it clear that the intermediate handrail is recognized and does not reduce the width.

Cost Impact: The code change proposal will not increase the cost of construction.

Public Hearing: Committee: AS AM D
Assembly: ASF AMF DF

ICCFILENAME:Boecker-E3-1012.8

E100–09/10

1002.1, 1013.2 (IFC [B] 1002.1, 1013.2); IRC R202, R312.2

Proponent: Paul K. Heilstedt, PE, FAIA, Chair, representing ICC Code Technology Committee (CTC)

THIS IS A 2 PART CODE CHANGE. PART I WILL BE HEARD BY THE IBC MEANS OF EGRESS COMMITTEE. PART II WILL BE HEARD BY THE IRC BUILDING/ENERGY COMMITTEE. SEE THE TENTATIVE HEARING ORDER FOR THESE COMMITTEES.

PART I – IBC MEANS OF EGRESS

1. Add new definition as follows:

1002.1 (IFC [B] 1002.1) Definitions. The following words and terms shall, for the purposes of this chapter and as used elsewhere in this code, have the meanings shown herein.

FIXED SEATING. Furniture or fixture designed and installed for the use of sitting and secured in place including bench-type seats and seats with or without back or arm rests.

2. Revise as follows:

1013.2 (IFC [B] 1013.2) Height. Required guards shall not be less than 42 inches (1067 mm) high, measured vertically ~~above the~~ as follows:

1. From the adjacent walking surfaces,
2. From a seat surface of adjacent fixed seating, with or without arm or back rests, within 22 inches of a required guard, the guard height shall provide a minimum 42 inches measured diagonally between the top of the guard and the nearest edge of the seat surface ~~or~~
3. On stairs, from the line connecting the leading edges of the ~~tread~~ treads nosings, and
4. On ramps, from the ramp surface at the guard.

Exceptions:

1. For occupancies in Group R-3, and within individual dwelling units in occupancies in Group R-2, *guards* on the open sides of *stairs* shall have a height not less than 34 inches (864 mm) measured vertically from a line connecting the leading edges of the treads.
2. For occupancies in Group R-3, and within individual dwelling units in occupancies in Group R-2, where the top of the *guard* also serves as a *handrail* on the open sides of *stairs*, the top of the *guard* shall not be less than 34 inches (864 mm) and not more than 38 inches (965 mm) measured vertically from a line connecting the leading edges of the treads.
3. The guard height in front row assembly seating areas ~~complying shall be in accordance~~ with Section 1028.14.
4. Along *alternating tread devices* and ship ladders, *guards* whose top rail also serves as a *handrail*, shall have height not less than 30 inches (762 mm) and not more than 34 inches (864 mm), measured vertically from the leading edge of the device *tread nosing*.

PART II – IRC BUILDING/ENERGY

1. Add new definition as follows:

SECTION R202 DEFINITIONS

FIXED SEATING. Furniture or fixture designed and installed for the use of sitting and secured in place including bench-type seats and seats with or without back or arm rests.

2. Revise as follows:

R312.2 Height. Required guards at open-sided walking surfaces, including stairs, porches, balconies or landings, shall be not less than 36 inches high measured vertically ~~above the~~ as follows:

1. From the adjacent walking surface,
2. From a seat surface of adjacent fixed seating, with or without arm or back rests, within 22 inches of the required guard, the guard height shall provide a minimum 36 inches measured diagonally between the top of the guard and the nearest edge of the seat surface ~~or~~
3. On stairs, from the line connecting the leading edges of the tread ~~treads~~ nosings and
4. On ramps, from the ramp surface at the guard.

Exceptions:

1. Guards on the open sides of stairs shall have a height not less than 34 inches (864 mm) measured vertically from a line connecting the leading edges of the treads.
2. Where the top of the guard also serves as a handrail on the open sides of stairs, the top of the guard shall not be not less than 34 inches (864 mm) and not more than 38 inches (965 mm) measured vertically from a line connecting the leading edges of the treads.

Reason: The ICC Board established the ICC Code Technology Committee (CTC) as the venue to discuss contemporary code issues in a committee setting which provides the necessary time and flexibility to allow for full participation and input by any interested party. The code issues are assigned to the CTC by the ICC Board as “areas of study”. Information on the CTC, including: meeting agendas; minutes; reports; resource documents; presentations; and all other materials developed in conjunction with the CTC effort can be downloaded from the following website: <http://www.iccsafe.org/cs/cc/ctc/index.html>. Since its inception in April/2005, the CTC has held seventeen meetings - all open to the public.

This proposed change is a result of the CTC’s investigation of the area of study entitled “Climbable Guards”. The scope of the activity is noted as:

The study of climbable guards will focus on determining the need for appropriate measures to prevent or inhibit an individual from utilizing the elements of a guard system, including rails, balusters and ornamental patterns, to climb the guard, thereby subjecting that person to the falling hazard which the guard system is intended to prevent.

The purposes of this proposal are to address several items raised last cycle during consideration of code change E85-07/08 which was approved. In particular, this proposal clarifies what constitutes “fixed seating” and proposes a horizontal distance between an object that reduces the “effective” height of a required guard rather than placing total reliance on the term “adjacent”.

Definition: The definition of “fixed seating” provides for a common understanding where the term is used. This was a concern that was raised in Public Comment #2 to E85 which was not successful.

Item #2: The concern addressed in this revision is that of fixed seating, with or without arm rests and with or without back rests including bench seating located within 22” of the guard. This seating provides a potential standing surface which as a result reduces the effective height of the guard. For seating within 22” of the guard, the guard height is to be measured diagonally from the nearest edge of the seat to the top of the guard. This measurement method is currently utilized in Section 1028.14.3. The guard would be required to extend past the “last” seat in a row so that the guard top is 42” above the edge of the last seat.

The distance of 22” utilized in this exception has been determined by CTC to be a reasonable distance for the purpose described.

Item #3: The current text is modified to indicate that the line is to be between the tread nosings. In the case of a single riser, hence a single nosing, a minimum tread depth of 11 inches on the lower walking surface establishes the slope.

Item #4: The guard height at the edge of a ramp is to be measured at the guard without consideration for the ramp slope as the dimensional change in the guard height is relatively insignificant. With a ramp slope towards the guard of 1/12, the highest point 22” from the guard is 1.83 inches above the ramp surface at the guard. If the ramp slope is 1/8, at 22” from the guard, the ramp surface is 2.75 inches above the ramp surface at the guard.

IBC Exception 3: The provisions for guard reduction for front row seating are primarily intended to accommodate the sight line for seated occupants- see section 1028.14.2. The seating within 22 inches of the guards elsewhere would necessitate an increase in the required guard height as indicated in **Item #2**.

PART I – IBC MEANS OF EGRESS

Public Hearing: Committee:	AS	AM	D
Assembly:	ASF	AMF	DF

PART II – IRC BUILDING/ENERGY

Public Hearing: Committee: AS AM D
Assembly: ASF AMF DF

ICCFILENAME:Heilstedt-E3-1013.2

E101–09/10 1013.2 (IFC [B] 1013.2)

Proponent: John Woestman, The Kellen Company, representing the Composite Lumber Manufacturers Association (CLMA)

Revise as follows:

1013.2 (IFC [B] 1013.2) Height. Required guards shall be not less than 42 inches (1067 mm) high, measured vertically above the adjacent walking surfaces, adjacent fixed seating or the line connecting the leading edges of the treads.

Exceptions:

1. For occupancy Group R-3 not more than three stories above grade in height and individual dwelling units in occupancy Group R-2 not more than three stories above grade in height with separate means of egress, required guards shall not be less than 36 inches (914 mm) high measured vertically above the adjacent walking surfaces, adjacent fixed seating or the line connecting the leading edges of the treads.
- ~~2.4.~~ For occupancies in Group R-3, and within individual dwelling units in occupancies in Group R-2, guards on the open sides of stairs shall have a height not less than 34 inches (864 mm) measured vertically from a line connecting the leading edges of the treads.
- ~~3.2.~~ For occupancies in Group R-3, and within individual dwelling units in occupancies in Group R-2, where the top of the guard also serves as a handrail on the open sides of stairs, the top of the guard shall not be less than 34 inches (864 mm) and not more than 38 inches (965 mm) measured vertically from a line connecting the leading edges of the treads.
- ~~4.3.~~ The height in assembly seating areas shall be in accordance with Section 1028.14.
- ~~5.4.~~ Along alternating tread devices and ship ladders, guards whose top rail also serves as a handrail, shall have height not less than 30 inches (762 mm) and not more than 34 inches (864 mm), measured vertically from the leading edge of the device tread nosing.

Reason: This proposal revises the IBC such that guards for one or two family occupancies not more than three stories above-grade in height and individual dwelling units in occupancy Group R-2 not more than three stories above-grade in height with a separate means of egress (i.e. townhouses) may be constructed to the same height requirements as the IRC. This disconnect between the IBC and the IRC has become quite visible in a large jurisdiction that adopted the IBC, but not the IRC, and has been applying the IBC to one and two family dwellings and to townhouses.

Cost Impact: The code change proposal will not increase the cost of construction.

Analysis: The corresponding section in the International Residential Code is Section R312.2.

Public Hearing: Committee: AS AM D
Assembly: ASF AMF DF

ICCFILENAME:Woestman-E3-1013.2

E102–09/10 1013.2 (IFC [B] 1013.2)

Proponent: Kerwin Lee, AIA, CASp, Rolf Jensen & Associates

Revise as follows:

1013.2 (IFC [B] 1013.2) Height. Required guards shall be not less than 42 inches (1067 mm) high, measured vertically above the adjacent walking surfaces, adjacent fixed seating or the line connecting the leading edges of the treads.

Exceptions:

1. For occupancies in Group R-3, and within individual dwelling units in occupancies in Group R-2, guards on the open sides of stairs shall have a height not less than 34 inches (864 mm) measured vertically from a line connecting the leading edges of the treads.
2. For occupancies in Group R-3, and within individual dwelling units in occupancies in Group R-2, where the top of the guard also serves as a handrail on the open sides of stairs, the top of the guard shall not be less than 34 inches (864 mm) and not more than 38 inches (965 mm) measured vertically from a line connecting the leading edges of the treads.
3. The height in assembly seating areas shall be in accordance with Section 1028.14.
4. Along alternating tread devices and ship ladders, guards whose top rail also serves as a handrail, shall have height not less than 30 inches (762 mm) and not more than 34 inches (864 mm), measured vertically from the leading edge of the device tread nosing.
5. In other than Group E occupancies, guards along stairways shall not be less than 34 inches (864mm) in height above the leading edge of the tread, where the stairway reverse direction at an intermediate landing and the opening between successive flights is 8 inches (203mm) or less, measured horizontally.

Reason: This language is taken from the National Building code. The code does not specifically address if a guard is required in a standard stair that switches back on itself. If the opening between the stair runs is 8 inches or less a guard should not be required. (Section 1013.3 limits openings to 8 inches above 34 inches when the opening is 34 inches or more above the surface). Normally these types of stairs are used for egress only and people do not stop along the stair. Once on the stair run, the user continues to the landing and next run of stairs. The need for a guard is not necessary in these situations. The exception to the exception is with E occupancies where children are present.

Cost Impact: No anticipated cost impact for construction.

Public Hearing: Committee:	AS	AM	D
Assembly:	ASF	AMF	DF

ICCFILENAME:Lee-E1-1013.2

E103-09/10

1014.2, Table 1018.1 (IFC [B] 1014.2, Table 1018.1)

Proponent: Dennis Richardson PE / dbr group inc. representing self

Revise as follows:

1014.2 (IFC [B] 1014.2) Egress through intervening spaces. Egress through intervening spaces shall comply with this section.

1. Egress from a room or space shall not pass through adjoining or intervening rooms or areas, except where such adjoining rooms or areas and the area served are accessory to one or the other, are not a Group H occupancy and provide a discernible path of egress travel to an *exit*.

Exception: *Means of egress* are not prohibited through adjoining or intervening rooms or spaces in a Group H, S or F occupancy when the adjoining or intervening rooms or spaces are the same or a lesser hazard occupancy group.

2. An *exit access* shall not pass through a room that can be locked to prevent egress.
3. *Means of egress* from dwelling units or sleeping areas shall not lead through other sleeping areas, toilet rooms or bathrooms.
4. Egress shall not pass through kitchens, storage rooms, closets or spaces used for similar purposes.

Exceptions:

1. *Means of egress* are not prohibited through a kitchen area serving adjoining rooms constituting part of the same dwelling unit or sleeping unit.
2. *Means of egress* are not prohibited through stockrooms in Group M occupancies when all of the following are met:
 - 2.1. The stock is of the same hazard classification as that found in the main retail area;
 - 2.2. Not more than 50 percent of the *exit access* is through the stockroom;
 - 2.3. The stockroom is not subject to locking from the egress side; and

2.4. There is a demarcated, minimum 44-inch-wide (1118 mm) *aisle* defined by full- or partial-height fixed walls or similar construction that will maintain the required width and lead directly from the retail area to the *exit* without obstructions.

5. Egress from a Group A or E occupancy room or space with an occupant load of 501-1000 that passes through non-rated corridors, or adjoining or intervening rooms or areas, shall have at least one of the three required means of egress:

5.1. Directly from the room to an exit;

5.2. Through a one hour corridor; or

5.3. Passing through a smoke compartment protected area, meeting the provisions of Section 1014.2 and restricting the movement of smoke from other exit access areas

6. Egress from a Group A or E occupancy room or space with an occupant load of more than 1000 that passes through non-rated corridors, or adjoining or intervening rooms or areas, shall have at least two of the four required means of egress:

6.1. Directly from the room to an exit;

6.2. Through a one hour corridor; or

6.3. Passing through a smoke compartment protected area, meeting the provisions of Section 1014.2 and restricting the movement of smoke from other exit access areas

**TABLE 1018.1 (IFC [B] TABLE 1018.1)
CORRIDOR FIRE-RESISTANCE RATING.**

OCCUPANCY	OCCUPANT LOAD SERVED BY ORRIDOR	REQUIRED FIRE-RESISTANCE RATING (hours)	
		Without sprinkler system	With sprinkler system ^C
H-1, H-2, H-3	All	Not Permitted	1
H-4, H-5	Greater than 30	Not Permitted	1
A ^d , B, E ^d , F, M, S, U	Greater than 30	1	0
R	Greater than 10	Not Permitted	0.5
I-2 ^a , I-4	All	Not Permitted	0
I-1, I-3	All	Not Permitted	1 ^b

a. For requirements for occupancies in Group I-2, see Sections 407.2 and 407.3.

b. For a reduction in the fire-resistance rating for occupancies in Group I-3, see Section 408.8.

c. Buildings equipped throughout with an automatic sprinkler system in accordance with Section 903.3.1.1 or 903.3.1.2 where allowed

d. For requirement for occupancies in Group A and E, see Section 1014.2, Items 5 and 6.

Reason :The number one complaint heard when teaching egress classes on the IBC is about the language found in Section 1014.2 requiring a “discernible path of egress travel to an *exit*” for egress through intervening spaces. This language is subject to a wide variety of interpretation resulting in non-uniform enforcement. Concern about this language is greatest in situations where a large number of occupants requiring multiple egress paths can wander through an area that is unfamiliar and shares a common atmosphere causing all means of egress paths to potentially fill with smoke from a single source in the event of a fire. There is little in the code other than the language “a discernible path of egress travel to an *exit*” and overall exit travel distance restrictions to provide a minimum level of safety even for large assembly or educational areas surrounded by a number of interconnected spaces. This situation is becoming more common when large warehouse facilities are converted to a church or recreational facility.

This proposal would require at least one of three required means of egress for assembly and educational occupancies of 501 to 1000 occupant load, and at least two of four required means of egress for assembly and educational occupancies of more than 1000 occupant load to be directly into an exit or through a one hour corridor or passing through an area constructed as a smoke compartment independent from other exit access areas. This proposal provides a bare minimum level of independent refuge from smoke for paths of egress from large assembly and educational occupancies. As part of this proposal, a footnote is added to Table 1018.1 to point users of code to this section which affects assembly and educational occupancies with non-rated corridors.

Cost Impact: Since many designers already provide some level of protected means of egress or direct exits this proposal would not add cost to projects in most cases. This proposal could add cost in instances where designers rely solely on a number of egress paths through intervening rooms or spaces for large occupant loads.

Public Hearing: Committee: AS AM D
 Assembly: ASF AMF DF

ICCFILENAME:Richardson-E2-1014.2

E104-09/10

1002.1, 1014.2.2 - 1014.2.7, 1015.1, Table 1015.1; (IFC [B] 1002.1, 1014.2.2 - 1014.2.7, 1015.1, Table 1015.1)

Proponent: Paul K. Heilstedt, PE, FAIA, Chair, representing ICC Code Technology Committee (CTC)

Revise as follows:

1002.1 (IFC [B] 1002.1) Definitions. The following words and terms shall, for the purposes of this chapter and as used elsewhere in this code, have the meanings shown herein.

CARE SUITE. A group of patient treatment rooms, patient care recipient sleeping rooms and their associated support rooms or spaces and circulation space within Group I-2 occupancies where staff are in attendance for supervision of all patients care recipients within the suite, and the suite is in conformance with the requirements of Section 1014.2.2 through 1014.2.6.

1014.2.2 (IFC [B] 1014.2.2) Group I-2. Habitable rooms ~~or suites~~ in Group I-2 occupancies shall have an *exit access* door leading directly to a *corridor*.

Exceptions:

1. Rooms with *exit* doors opening directly to the outside at ground level.
2. Rooms arranged as care suites complying with Section 1014.2.4

~~1014.2.6~~ **1014.2.3 (IFC [B] 1014.2.3) Travel distance.** The travel distance between any point in a Group I-2 occupancy ~~patient~~ sleeping room and an *exit access* door in that room shall not exceed 50 feet (15 240 mm).

1014.2.4 (IFC [B] 1014.2.4) Group I-2 care suites. Care suites in Group I-2 shall comply with Section 1014.2.4.1 through 1014.2.4.4 and either Section 1014.2.4.5 or 1014.2.4.6.

~~1014.2.5~~ **1014.2.4.1 (IFC [B] 1014.2.4.1) Exit access through care suites.** *Exit access* from all other portions of a building not classified as a *care suite* in a Group I-2 occupancy shall not pass through a *care suite*. In a *care suite* required to have more than one exit, one exit access may pass through an adjacent care suite provided all of the other requirements of Section 1014.2 are satisfied.

~~1014.2.7~~ **1014.2.4.2 (IFC [B] 1014.2.4.2) Separation.** Care suites in Group I-2 occupancies shall be separated from other portions of the building by a *smoke partition* complying with Section 711.

1014.2.4.3 (IFC [B] 1014.2.4.3) One intervening room. For rooms other than ~~patient~~ sleeping rooms located within a *care suite*, ~~suites of rooms are~~ exit access travel from the care suite shall be permitted to have through one intervening room where if the travel distance within the *suite* to the *exit access* door from the care suite is not greater than 100 feet (30 480 mm).

1014.2.4.4 (IFC [B] 1014.2.4.4) Two intervening rooms. For rooms other than ~~patient~~ sleeping rooms located within a *care suite*, *exit access* travel from within the *care suite* shall be permitted through two intervening rooms where the travel distance to the *exit access* door from the care suite is not greater than 50 feet (15 240 mm).

~~1014.2.3~~ **1014.2.4.5 (IFC [B] 1014.2.3 1014.2.4.5) Care suites containing in-patient sleeping rooms areas.** Patient Sleeping rooms areas in Group I-2 occupancies shall be permitted to be grouped divided into *care suites* with one intervening room if one of the following conditions is met:

1. The intervening room within the *care suite* is not used as an *exit access* for more than eight ~~patient~~ care recipient beds.
2. The arrangement of the *care suite* allows for direct and constant visual supervision by ~~nursing~~ personnel care providers.

~~1014.2.4.5.1~~ **1014.2.3.1 (IFC [B] 1014.2.4.5.1 1014.2.3.1) Area.** Care suites containing of sleeping rooms shall not exceed 5,000 square feet (465 m²).

1014.2.4.5.2 1014.2.3.2 (IFC [B] 1014.2.4.5.2 1014.2.3.2) Exit access. Any patient sleeping room, or any care suite that contains patient sleeping rooms, of more than 1,000 square feet (93 m²) shall have at least two exit access doors from the care suite ~~remotely located in accordance with Section 1015.2. from each other.~~

1014.2.4.5.3 1014.2.3.3 (IFC [B] 1014.2.4.5.3 1014.2.3.3) Travel distance. The travel distance between any point in a care suite containing sleeping rooms and an exit access door of from that care suite shall not exceed 100 feet (30 480 mm).

1014.2.4.6 1014.2.4 (IFC [B] 1014.2.4.6 1014.2.4) Care Suites not containing sleeping rooms, in areas other than patient sleeping areas. Areas not containing sleeping rooms, but only treatment areas and the associated rooms, spaces or circulation space other than patient sleeping areas in Group I-2 occupancies shall be permitted to be grouped into care suites and shall conform to the limitations in Section 1014.2.4.6.1 and 1014.4.6.2. be permitted to be divided into suites.

1014.2.4.6.1 1014.2.4.1 (IFC [B] 1014.2.4.6.1 1014.2.4.1) Area. Care suites of rooms, other than patient sleeping rooms, shall not exceed 10,000 square feet (929 m²).

1014.2.4.6.2 1014.2.4.2 (IFC [B] 1014.2.4.6.2 1014.2.4.2) Exit access. Care suites Any room or group of rooms, other than patient sleeping rooms, of more than 2,500 square feet (232 m²) shall have at least two exit access doors from the care suite located in accordance with Section 1015.2. ~~remotely located from each other.~~

1015.1 (IFC [B] 1015.1) Exits or exit access doorways from spaces. Two exits or exit access doorways from any space shall be provided where one of the following conditions exists:

Exception: Group I-2 occupancies shall comply with Section 1014.2.2 through 1014.2.7.

1. The occupant load of the space exceeds one of the values in Table 1015.1.

Exceptions:

1. In Group R-2 and R-3 occupancies, one means of egress is permitted within and from individual dwelling units with a maximum occupant load of 20 where the dwelling unit is equipped throughout with an automatic sprinkler system in accordance with Section 903.3.1.1 or 903.3.1.2.
2. Care suites in Group I-2 occupancies complying with Section 1014.2.2 through 1014.2.4.6.2.
2. The common path of egress travel exceeds one of the limitations of Section 1014.3.
3. Where required by Section 1015.3, 1015.4, 1015.5, 1015.6 or 1015.6.1.

Where a building contains mixed occupancies, each individual occupancy shall comply with the applicable requirements for that occupancy. Where applicable, cumulative occupant loads from adjacent occupancies shall be considered in accordance with the provisions of Section 1004.1.

**TABLE 1015.1 (IFC [B] TABLE 1015.1)
SPACES WITH ONE EXIT OR EXIT ACCESS DOORWAY**

OCCUPANCY	MAXIMUM OCCUPANT LOAD
A, B, E ^a , F, M, U	49
H-1, H-2, H-3	3
H-4, H-5, I-1, I-2, I-3, I-4, R	10
S	29

a. Day care maximum occupant load is 10.

Reason: The ICC Board established the ICC Code Technology Committee (CTC) as the venue to discuss contemporary code issues in a committee setting which provides the necessary time and flexibility to allow for full participation and input by any interested party. The code issues are assigned to the CTC by the ICC Board as "areas of study". Information on the CTC, including: meeting agendas; minutes; reports; resource documents; presentations; and all other materials developed in conjunction with the CTC effort can be downloaded from the following website: <http://www.iccsafe.org/cs/cc/ctc/index.html>. Since its inception in April/2005, the CTC has held seventeen meetings - all open to the public.

This proposed change is a result of the CTC's investigation of the area of study entitled "Care Facilities". The scope of the activity is noted as:

Study issues associated with Day Care/Adult Care, Ambulatory Health Care and Assisted Living facilities with an emphasis on the number of occupants in relation to the supervision, and the determination of the resident's capability of responding to an emergency situation without physical assistance from the facility's supervision.

The Code Technology Committee Study Group on Care Facilities has conducted a comprehensive review of current building and fire codes, federal regulations and prior code change proposals dealing with the provision of "care". "Care" as it relates to the scope of this work relates to an occupant of a building who is compromised (mentally or physically) and receives some type of support (care). These facilities encompass a full spectrum of acuity and span a wide range of occupancy types including Groups B, E, I and R. On the lower end of the spectrum, occupants may be aged and receive occasional day living assistance such as cooking and cleaning. On the opposite end of the spectrum, occupants may be completely bedridden and dependant on medical gases and emergency power to maintain life.

The proposed changes provide clear direction for design and construction by using terms and concepts consistently and clearly identifying thresholds related to the condition of an occupant. Federal regulations and state licensing provisions were considered, but primarily in terms of avoiding conflicting requirements. It is not the intent of these changes to address licensing or operational issues. We do believe that the proposed changes will provide consistent and correlated language between these multiple sources of regulations that will help design and code professionals address the needs of care recipients in the many different types of facilities.

A major goal is to provide clarity and consistency of terminology. New definitions are added to specifically describe each type of care or facility and identify the distinct differences in these. Some terms are consolidated to be more descriptive of a group of occupants, yet generic enough to be used interchangeably. For example: a "Patient" is now identified as a "care recipient" and "nurse" is now "care provider". People receive care of varying types but they are not always referred to as "patients". They receive care from a wide range of persons with different technical abilities, not just a "nurse" or "staff". Other definitions address existing terms not defined within current code. The study group believes that these changes bring a practical response to the recent developments within the healthcare delivery system.

Care Suites –

This proposal includes changes identified by the ICC CTC care facilities study group in their efforts to coordinate the sections of this Code dealing with the provision of "care". During the course of this study, several items were identified within this section dealing with suites within Group I-2 occupancies. Changes to this section include:

Clarification that the definition applies only to "care suites" used as related to patient sleeping or treatment. This addresses the confusion caused by tenant spaces in other occupancy types that are referred to or addressed as "suite."

The definition of care suite has been modified to correct an unintended consequence of the 2009 code. The proposal clarifies that support spaces, such as clean and soiled utility room and nurses stations are allowed within the suite.

Sections have been re-ordered so that general requirements that apply to all suites are located near the charging section.

The reference to the term "patient" has been replaced with "care recipient" as consistent with other proposals by the CTC. Since the definition of care suite includes the reference to care recipient, wherever possible the term is not repeated in each section.

The requirement for remoteness of exits has been clarified with a reference to the established calculation of remoteness as defined by Section 1015.2

Lastly, a modification is proposed that would allow the second required exit to pass through another suite. This concept is allowed by several jurisdictions and provides a similar safeguard by allowing suite occupants to pass through a smoke partition to a separate atmosphere. This allowance is limited to the second required exit. Single exit suites would not qualify for this allowance.

Section 1015.1

The change made to this section attempts to clarify the existing language. Group I-2 was added to Table 1015.1 to address areas that are not care suites. Spaces that were not suites were not previously addressed in this table. The existing exception to the charging language is more appropriately an exception to condition #1.

Cost Impact: None given.

Public Hearing: Committee:	AS	AM	D
Assembly:	ASF	AMF	DF

ICCFILENAME:Heilstedt-E1-1002.1

E105–09/10

1014.3, Table 1014.3 (New) [IFC [B] 1014.3, Table 1014.3 (New)]

Proponent: Homer Maiel, PE, CBO, City of San Jose, representing ICC Tri-Chapter (Peninsula, East Bay, Monterey Bay)

1. Revise as follows:

1014.3 (IFC [B] 1014.3) Common path of egress travel. The common path of egress travel shall not exceed the travel distances in Table 1014.3. In occupancies other than Groups H-1, H-2 and H-3, the common path of egress travel shall not exceed 75 feet (22 860 mm). In Group H-1, H-2 and H-3 occupancies, the common path of egress travel shall not exceed 25 feet (7620 mm). For common path of egress travel in Group A occupancies and assembly occupancies accessory to Group E occupancies having fixed seating, see Section 1028.8.

~~Exceptions:~~

- ~~1. The length of a common path of egress travel in Group B, F and S occupancies shall not be more than 100 feet (30 480 mm), provided that the building is equipped throughout with an automatic sprinkler system installed in accordance with Section 903.3.1.1.~~

2. Where a tenant space in Group B, S and U occupancies has an occupant load of not more than 30, the length of a common path of egress travel shall not be more than 100 feet (30 480 mm).
3. The length of a common path of egress travel in a Group I-3 occupancy shall not be more than 100 feet (30 480 mm).
4. The length of a common path of egress travel in a Group R-2 occupancy shall not be more than 125 feet (38 100 mm), provided that the building is protected throughout with an approved automatic sprinkler system in accordance with Section 903.3.1.1 or 903.3.1.2.

2. Add new Table as follows:

**TABLE 1014.3 (IFC TABLE [B] 1014.3)
COMMON PATH OF EGRESS TRAVEL**

OCCUPANCY	WITHOUT SPRINKLER SYSTEM (feet)			WITH SPRINKLER SYSTEM ^a (feet)
	Any Occupant Load (OL)	Occupant Load		
		OL 30	OL 30	
B, S	Not Applicable	100	75	100
U	Not Applicable	100	75	75
F	75	Not Applicable	Not Applicable	100
H-1, H-2, H-3	Not Permitted	Not Permitted	Not Permitted	25
R-2	75	Not Applicable	Not Applicable	125 ^b
I-3	100	Not Applicable	Not Applicable	100
All others ^c	75	Not Applicable	Not Applicable	75

- a. Approved automatic sprinkler system in accordance with Section 903.3.1.1
- b. Approved automatic sprinkler system in accordance with Section 903.3.1.1 or 903.3.1.2
- c. For Group A occupancies and assembly occupancies accessory to Group E occupancies having fixed seating, see Section 1025.8

Reason: This is an editorial change to simplify this code section. The existing paragraphs, with accompanying exceptions, have been replaced with a table which is easier to understand and follow. The content and code requirements are not altered in any form or shape.

Cost Impact: The code change proposal will not increase the cost of construction.

Public Hearing: Committee: AS AM D
 Assembly: ASF AMF DF

ICCFILENAME:Maiei-E2-1014.3

E106-09/10 1014.3 (IFC [B] 1014.3)

Proponent: Gene Boecker, Code Consultants Inc., representing Code Consultants, Inc.

Revise as follows:

1014.3 (IFC [B] 1014.3) Common path of egress travel. In occupancies other than Groups H-1, H-2 and H-3, the common path of egress travel shall not exceed 75 feet (22 860 mm). In Groups H-1, H-2 and H-3 occupancies, the common path of egress travel shall not exceed 25 feet (7620 mm). For common path of egress travel in Group A occupancies and assembly occupancies accessory to Group E occupancies having fixed seating, see Section 1028.8

Exceptions:

1. The length of a common path of egress travel in Group B, F and S occupancies shall not be more than 100 feet (30 480 mm), provided that the building is equipped throughout with an automatic sprinkler system installed in accordance with Section 903.3.1.1.
2. Where a tenant space in Group B, S and U occupancies has an occupant load of not more than 30, the length of a common path of egress travel shall not be more than 100 feet (30 480 mm).
3. The length of a common path of egress travel in a Group I-3 occupancy shall not be more than 100 feet (30 480 mm).
4. The length of a common path of egress travel in a Group R-2 or R-3 occupancy shall not be more than 125 feet (38 100 mm), provided that the building is protected throughout with an approved automatic sprinkler system in accordance with Section 903.3.1.1 or 903.3.1.2.

Reason It is only appropriate that the exception should apply to a dwelling unit that is a single or double and not “three or more.” Where a dwelling unit is associated with another occupancy and there are multiple apartments it will be an R-2 occupancy. If there is only the owner’s apartment or two small apartments, then it would be treated as an R-3 occupancy. This is the case in urban areas. Additionally, R-3 needs the second means of egress where the area of the dwelling unit exceeds 4,000 sf (resulting in an occupant load >20) or where the unit is more than 3 stories in height.

By extending the exception to these dwelling units, it is only clarifying that the same rules apply to these types of uses whether there are one, two or three units in the same building.

Cost Impact: The code change proposal will not increase the cost of construction.

Public Hearing: Committee:	AS	AM	D
Assembly:	ASF	AMF	DF

ICCFILENAME:Boecker-E4-1014.3

E107–09/10

1015.2.1 (IFC [B] 1015.2.1)

Proponent: Homer Maiel, PE, CBO, City of San Jose, representing ICC Tri-Chapter (Peninsula, East Bay, Monterey Bay)

Revise as follows:

1015.2.1 (IFC [B] 1015.2.1) Two exits or exit access doorways. Where two exits or exit access doorways are required from any portion of the exit access, the exit doors or exit access doorways shall be placed a distance apart equal to not less than one-half of the length of the maximum overall diagonal dimension of the building or area to be served measured in a straight line between exit doors or exit access doorways. Interlocking or scissor stairs shall be counted as one exit stairway.

Exceptions:

1. Where exit enclosures are provided as a portion of the required exit and are interconnected by a 1-hour fire-resistance-rated corridor conforming to the requirements of Section 1018, the required exit separation shall be measured along the shortest direct line of travel within the corridor. The exit or exit access doorway to such enclosures shall not be less than 25 feet (7.62 m), measured in a straight line, from the exit or exit access doorway of another exit enclosure.
2. Where a building is equipped throughout with an automatic sprinkler system in accordance with Section 903.3.1.1 or 903.3.1.2, the separation distance of the exit doors or exit access doorways shall not be less than one-third of the length of the maximum overall diagonal dimension of the area served.

Reason: The current exception 1 allows the separation of two exits to be measured in a line of travel within a rated corridor. Although this length (traveling within a corridor) may be longer than one-half of the overall diagonal, the exit enclosures can be placed very close to each other. Thus a fire could compromise both exits. Furthermore, the travel distance in the corridor can be reduced to one third (per exception 2) which can further exacerbate this problem.

Cost Impact: The code change proposal will not increase the cost of construction.

Public Hearing: Committee:	AS	AM	D
Assembly:	ASF	AMF	DF

ICCFILENAME:Maiel-E1-1015.2.1

E108–09/10

1016.1, 1022.1 (IFC [B] 1016.1, 1022.1)

Proponent: Ronald W. Clements, Jr., representing Chesterfield County Virginia Building Inspection Department; Gregory R. Keith, Professional heuristic Development, representing The Boeing Company; and Michael L. Perrino, CBO, representing Code Consultants, Inc.; Sarah Rice, CBO, representing self

Revise as follows:

1016.1 (IFC [B] 1016.1) Travel distance limitations. Exits shall be so located on each story such that the maximum length of exit access travel, measured from the most remote point within a story along the natural and unobstructed path of egress travel to an exterior door at the level of exit discharge, an entrance to a vertical exit enclosure, an exit passageway, a horizontal exit, an exterior exit stairway or an exterior exit ramp shall not exceed the distances given in Table 1016.1.

Exceptions:

1. Travel distance in open parking garages is permitted to be measured to the closest riser of open exit stairways.
2. In outdoor facilities with open exit access components and open exterior exit stairways or exit ramps, travel distance is permitted to be measured to the closest riser of an exit stairway or the closest slope of the exit ramp.
3. ~~In other than occupancy Groups H and I, the exit access travel distance to a maximum of 50 percent of the exits is permitted to be measured from the most remote point within a building to an exit using unenclosed exit access stairways or ramps when connecting a maximum of two stories. The two connected stories shall be provided with at least two means of egress. Such interconnected stories shall not be open to other stories.~~
4. ~~In other than occupancy Groups H and I, exit access travel distance is permitted to be measured from the most remote point within a building to an exit using unenclosed exit access stairways or ramps in the first and second stories above grade plane in buildings equipped throughout with an automatic sprinkler system in accordance with Section 903.3.1.1. The first and second stories above grade plane shall be provided with at least two means of egress. Such interconnected stories shall not be open to other stories.~~

Where applicable, travel distance on unenclosed exit access stairways or ramps and on connecting stories shall also be included in the travel distance measurement. The measurement along stairways shall be made on a plane parallel and tangent to the stair tread nosings in the center of the stairway.

1022.1 (IFC [B] 1022.1) Enclosures required. Interior exit stairways and interior exit ramps shall be enclosed with fire barriers constructed in accordance with Section 707 or horizontal assemblies constructed in accordance with Section 711, or both. Exit enclosures shall have a fire-resistance rating of not less than 2 hours where connecting four stories or more and not less than 1 hour where connecting less than four stories. The number of stories connected by the exit enclosure shall include any basements but not any mezzanines. Exit enclosures shall have a fire-resistance rating not less than the floor assembly penetrated but need not exceed 2 hours. Exit enclosures shall lead directly to the exterior of the building or shall be extended to the exterior of the building with an exit passageway conforming to the requirements of Section 1023, except as permitted in Section 1027.1. An exit enclosure shall not be used for any purpose other than means of egress.

Exceptions:

1. ~~In other than Group H and I occupancies, stairways and ramps that serve only one adjacent story need not be enclosed. Any two such interconnected stories shall not be open to other stories. In all occupancies, other than Groups H and I occupancies, a stairway is not required to be enclosed when the stairway serves an occupant load of less than 10 and the stairway complies with either Item 1.1 or 1.2. In all cases, the maximum number of connecting open stories shall not exceed two.~~
 - 1.1. ~~The stairway is open to not more than one story above its level of exit discharge, or~~
 - 1.2. ~~The stairway is open to not more than one story below its level of exit discharge.~~
2. Exits in buildings of Group A-5 where all portions of the means of egress are essentially open to the outside need not be enclosed.
3. Stairways serving and contained within a single residential dwelling unit or sleeping unit in Group R-1, R-2 or R-3 occupancies are not required to be enclosed.
4. Stairways in open parking structures that serve only the parking structure are not required to be enclosed.
5. Stairways in Group I-3 occupancies, as provided for in Section 408.3.8, are not required to be enclosed.
6. Means of egress stairways as required by Section 410.5.3 and 1015.6.1 are not required to be enclosed.
7. Means of egress stairways from balconies, galleries and press boxes as provided for in Section 1028.5.1, are not required to be enclosed.

Reason: This proposal is intended to correlate and correct fundamental interior exit stairway enclosure provisions. The history and technical inconsistency of current provisions were brought to light during ICC Code Technology Committee (CTC), Unenclosed Exit Stairway Study Group discussions associated with the drafting of a CTC code change proposal for the current (2009/2010) development cycle. One of the main charges of the study group was to validate the relationship between Chapter 10 required exit, access to exit, exit enclosure and exit access travel distance provisions. These provisions lie at the heart of means of egress design philosophy.

Unfortunately, the 2000 Edition of the IBC did not do a particularly good job of consolidating the means of egress provisions contained in the former model (legacy codes). This was owed to several factors, not the least of which was the significantly different systems or approaches to means of egress design used by the various contributing codes. This is probably best illustrated through the 2000 IBC exceptions to interior exit stairway enclosure requirements. In fact, none of the 2000 IBC general design related exceptions appeared in any of the legacy codes. The exceptions were spawned as compromises with former provisions. The BOCA building code fundamentally maintained that required interior exit stairways at all stories be enclosed. The ICBO building code, on the other hand, basically allowed that in other than Group H and I occupancies, exit

enclosures were not required for interior stairways serving only one adjacent story. The 2000 IBC resolved the issue by permitting 50% of the required stairways to be unenclosed. That provision supported neither legacy philosophy.

In subsequent editions, the related provisions have been manipulated to a point that current requirements create or support no functional means of egress strategy. Unfortunately, with the inability of the IBC to effectively state its intent, practitioners have largely resorted to their specific legacy indoctrination resulting in varying interpretations. In the 2003 Edition, an additional exception to exit enclosure provisions allowed for all interior exit stairways to be unenclosed at the first and second stories of a sprinklered building of other than Group H and I occupancies. The 2006 Edition formalized the concept of accessing required exits from adjacent levels by way of unenclosed interior stairways and ramps. In the 2009 Edition of the IBC, two fundamental exceptions to exit enclosure requirements were moved to Section 1016.1, travel distance provisions. As has been previously mentioned, various provisions have been manipulated over time in an attempt to contort them to a desired technical end. Virtually all of these attempts have failed to recognize the delicate technical relationships between the fundamental means of egress concepts of numbers of exits, access to required exits and exit access travel distance.

The 2009/2010 CTC interior stairway proposal effectively establishes such a system with supporting terminology and requirements based on current IBC means of egress provisions. The study group intentionally avoided including substantial technical changes in its code change proposal, although a majority of members may have agreed with a certain concept or provision.

This proposal is intended to further cultivate and clarify the IBC system of means of egress design. Essentially, it allows for a general two-story exception to the enclosure of required interior exit stairways in other than Group H and I occupancies. This arguably represents the cumulative impact of numerous current exceptions addressing unenclosed exits or access to exits. It also serves to reinforce access to exits at adjacent building level provisions. The ultimate goal is to require that all interior exit stairways (required exit components) be enclosed without specifying their required location. Effectively, this allows a given means of egress design to dictate which exit components are employed and where. It also acknowledges that exits may be accessed from an adjacent story or level within prescribed exit access travel distance limitations.

This proposal effectively integrates the related legacy requirements with current IBC provisions. The reason that this provision was not included in the 2009/2010 CTC interior stairway proposal is that it represents a relaxation of current IBC exit enclosure requirements. Again, please bear in mind that current IBC enclosure requirements are based on an ICC Means of Egress Drafting Committee technical compromise. What is recommended in this proposal is identical in concept to that of the former Uniform Building Code. Such a means of egress design method has decades of distinguished performance history. It is also consistent with the means of egress philosophy promoted in the 2009/2010 CTC interior stairway proposal. That is, that formal exits, or access to exits, shall be provided in prescribed numbers from each building level. Unenclosed stairways and ramps (certain occupancies notwithstanding) may access exits at an adjacent building level within prescribed exit access travel distance limitations. Accordingly, buildings more than two stories in height will have not less than two enclosed interior exit stairways. It is acknowledged that such exit enclosures may not serve all building stores based on the specific building and means of egress design; however, such enclosed exits are within the exit access travel distance limitations and are not more than one level removed from the exit. It should be noted that when exit enclosures are employed to support a given design, they typically serve all building stories. Occasionally, security or privacy concerns dictate that access to enclosed interior exit stairways at all stories is undesirable. Nevertheless, occupants at those levels have access to exits comparable to that required for any building level. Additionally, the fire service has protected enclosures to serve as staging areas for the attack of a fire at, above or below the story of incident origin.

In summary, this proposal eliminates many of the technical inconsistencies associated with current means of egress provisions. This proposal, in combination with the 2009/2010 CTC interior stairway proposal, effectively repairs the IBC means of egress system design requirements and their technical relationships. Each of the proponents of this proposal was a voting member of the ICC Code Technology Committee, Unenclosed Exit Stairway Study Group and they represent a majority of voting study group members.

Cost Impact: The code change proposal will not increase the cost of construction.

Public Hearing: Committee: AS AM D
 Assembly: ASF AMF DF

ICCFILENAME:Keith-Clements-Perrino-E1-1022.1

E109-09/10

1016.3 (New), Table 1016.3 (New), 1016.3.1 (New); [IFC [B] 1016.3 (New), Table 1016.3 (New), 1016.3.1 (New)]

Proponent: Jay Wallace, The Boeing Company and Gregory R. Keith, Professional heuristic Development, representing The Boeing Company

Add new text and table as follows:

1016.3 (IFC [B] 1016.3) Aircraft manufacturing facilities. In buildings used for the manufacturing of aircraft, exit access travel distances indicated in Section 1016.1 shall be increased in accordance with the following:

1. The building shall be of Type I or II construction.
2. Exit access travel distance shall not exceed the distances given in Table 1016.3.

**TABLE 1016.3 (IFC [B] TABLE 1016.3)
 AIRCRAFT MANUFACTURING EXIT ACCESS TRAVEL DISTANCE**

HEIGHT (feet) ^b	MANUFACTURING AREA (sq. ft.) ^a					
	≥150,000	≥200,000	≥250,000	≥500,000	≥750,000	≥1,000,000
≥ 25	400	450	500	500	500	500
≥ 50	400	500	600	700	700	700

<u>≥75</u>	<u>400</u>	<u>500</u>	<u>700</u>	<u>850</u>	<u>1,000</u>	<u>1,000</u>
<u>≥ 100</u>	<u>400</u>	<u>500</u>	<u>750</u>	<u>1,000</u>	<u>1,250</u>	<u>1,500</u>

For SI: 1 foot = 304.8 mm

- a. Contiguous floor area of the aircraft manufacturing facility having the indicated height.
- b. Minimum height from finished floor to bottom of ceiling or roof slab or deck.

1016.3.1 (IFC [B] 1016.3.1) Associated areas. Egress from rooms, areas and spaces associated with the primary manufacturing area shall be permitted through such area having a minimum height as indicated in Table 1016.3. Exit access travel distance within the associated room, area or space shall not exceed that indicated in Table 1016.1 based on the occupancy classification of that associated area. Total exit access travel distance shall not exceed that indicated in Table 1016.3.

Reason: Many aircraft manufacturing buildings are unusually large due to the size of the commercial or military aircraft being produced. For instance, an assembled Boeing 747 has a tail height of over 63 feet. The rectangular footprint of a Boeing 747-800 is over 56,000 square feet.

Group F-1 occupancies greater than 150,000 square feet can have difficulty complying with 250 foot, sprinklered exit access travel distance limitations without incorporating exit passageways or horizontal exits into the design of the building means of egress system. The use of either exit component is somewhat problematic. Due to the compartmentalized nature of horizontal exits, they do not lend to aircraft production processes or movement of the finally assembled aircraft. For similar reasons, exit passageways are generally installed below the floor of the assembly level. The use of underground exit passageways during an emergency in a very high volume space is generally contrary to human nature. Once aware of an event, employees would instinctively evacuate the building at the level with which they are most familiar. Also, it is relatively easy to move away from the point of origin of a fire due to a person's sensory awareness within the entire open space. Given the fact that occupants sense safety as they move away from the fire, it is counter-intuitive to enter an underground area unless as a last resort.

Regardless of human nature, it must be demonstrated that high volume spaces provide a tenable environment for the evacuation or relocation of building occupants. The Boeing Company conducted smoke and temperature fire modeling using the NIST FDS (National Institute of Standards and Technology - Fire Dynamics Simulator) computer program.

In order to establish a performance baseline, a series of worse case scenarios were combined into the first test. We referenced previous Boeing proprietary laboratory test data on a large, 10 megawatt fire and duplicated and calibrated those data in our fire and smoke model. We placed the 10 megawatt event in an interior corner of a 400 foot x 400 foot building with exterior exit doors at the midpoints of each exterior wall. A corner fire was considered worse case because anticipated radiation off of adjacent 90° walls focuses and accelerates the progression of the fire. The minimum ceiling height permitted in the means of egress by the International Building Code is 7'-6"--impractically low for an aircraft manufacturing area ceiling height. A similarly impractical ceiling height of 10 feet was selected as a worse case baseline for data determination purposes. Active fire suppression was not included in the model; therefore, the test fire burns until it is consumed. It should be noted that because sprinklers were not utilized in the model, they are not included as a requirement in the proposed provision. That being said, it is recognized that to achieve the qualifying contiguous areas of proposed Table 1016.3, the building would be sprinklered based on the fire area thresholds in Section 903. This proposal lets each issue stand on its own merit without introducing a new sprinkler trade-off. Also, for simplicity, it was also assumed that when smoke is introduced into the space, smoke detection would shut down any HVAC systems. Therefore, no mechanical ventilation is included in the model. The model assumed no fuel contribution by the building itself; therefore, the proposed provisions are limited to buildings of Type I or II construction.

Six modeling runs were conducted. One, for the 400 foot x 400 foot space with a 10 foot ceiling height for data base line purposes. Four additional runs were made for the same building area with ceiling heights of 25, 50, 75 and 100 feet for purposes of data development. One additional run was conducted for a 1,000,000 square foot building with a 100 foot ceiling height for data interpolation purposes. These data points were selected to support the area and height thresholds established in proposed Table 1016.3.

The 160,000 sf, 10' high ceiling baseline model indicates: (Maximum permitted travel distance: 200 feet [Group F-1, unsprinklered; Table 1016.1]. Based on an assumed rate of travel of 250 feet per minute, maximum travel time is 48 seconds.)

After 4 minutes, the exit nearest the point of origin of the fire is still completely free of smoke and heat from the fire. Ceiling temperatures near the source immediately reach 165 degrees and the fire sprinkler system would activate.

The 160,000 sf, 25' high ceiling model indicates: (Maximum proposed travel distance: 400 feet [≥150,000 sf, ≥ 25'; Table 1016.3]. Based on an assumed rate of travel of 250 feet per minute, maximum travel time is 96 seconds.)

After 120 seconds, the smoke plume extends approximately 100 feet from the point of origin of the fire. The smoke level is at approximately 20 feet above the floor. After 360 seconds, the smoke level is at approximately 10 feet above the floor (360 - 96 = 264 ÷ 96 = 2.75 factor of safety).

After 150 seconds, the ceiling temperature has just reached 165 degrees directly above the point of origin of the fire. Sprinkler activation occurs 54 seconds after building evacuation has occurred. After 300 seconds, no ceiling temperature is greater than 127 degrees.

The 160,000 sf, 50' high ceiling model indicates: (Maximum proposed travel distance: 400 feet [≥150,000 sf, ≥ 25'; Table 1016.3]. Based on an assumed rate of travel of 250 feet per minute, maximum travel time is 96 seconds.)

After 120 seconds, the smoke plume extends approximately 100 feet from the point of origin of the fire. The smoke level is at approximately 42 feet above the floor. After 420 seconds, the smoke level is at approximately 25 feet above the floor (420 - 96 = 324 ÷ 96 = 3.37 factor of safety).

After 150 seconds, the ceiling temperature is 108 degrees directly above the point of origin of the fire. Sprinkler activation occurs 84 seconds after building evacuation has occurred. After 300 seconds, no ceiling temperature is greater than 98.5 degrees.

The 160,000 sf, 75' high ceiling model indicates: (Maximum proposed travel distance: 400 feet [≥150,000 sf, ≥ 25'; Table 1016.3]. Based on an assumed rate of travel of 250 feet per minute, maximum travel time is 96 seconds.)

After 120 seconds, the smoke plume extends less than 100 feet from the point of origin of the fire. The smoke level is at approximately 60 feet above the floor. After 420 seconds, the smoke level is at approximately 25 feet above the floor at one point (420 - 96 = 324 ÷ 96 = 3.37 factor of safety).

After 150 seconds, the ceiling temperature is 98.5 degrees directly above the point of origin of the fire. Sprinkler activation occurs 144 seconds after building evacuation has occurred. After 300 seconds, no ceiling temperature is greater than 98.5 degrees.

The 160,000 sf, 100' high ceiling model indicates: (Maximum proposed travel distance: 400 feet [≥150,000 sf, ≥ 25'; Table 1016.3]. Based on an assumed rate of travel of 250 feet per minute, maximum travel time is 96 seconds.)

After 120 seconds, the smoke plume extends less than 100 feet from the point of origin of the fire. The smoke level is at approximately 85 feet above the floor. After 420 seconds, the smoke level is at approximately 30 feet above the floor at one point ($420 - 96 = 324 \div 96 = 3.37$ factor of safety).

After 150 seconds, the ceiling temperature is 89 degrees directly above the point of origin of the fire. Sprinkler activation occurs 144 seconds after building evacuation has occurred. After 300 seconds, no ceiling temperature is greater than 89 degrees.

The 1,000,000 sf, 100' high ceiling model indicates: (Maximum proposed travel distance: 1,500 feet [$\geq 1,000,000$ sf, $\geq 100'$; Table 1016.3]. Based on an assumed rate of travel of 250 feet per minute, maximum travel time is 360 seconds.)

After 360 seconds, the smoke plume extends less than 500 feet from the point of origin of the fire. The smoke level is at approximately 75 feet above the floor. After 720 seconds, the smoke level is still at approximately 75 feet above the floor ($720 - 360 = 360 \div 360 = 1.0$ factor of safety).

At 300 seconds, the ceiling temperature is 70 degrees directly above the point of origin of the fire. At 300 seconds, ceiling temperatures are dropping and no temperature is greater than 89 degrees.

Data clearly indicate that the proposed exit access travel distances for aircraft manufacturing facilities provide for a high for level of occupant tenability with a minimum factor of safety of 100 percent. It is intuitive that high volume spaces provide sufficient time for an occupant to safely access an exit. Nevertheless, The Boeing Company has reinforced that common sense through fire modeling that validates and quantifies that logic.

Most manufacturing facilities have other supporting occupancies including offices, break rooms, cafeterias, etc. This proposal would permit occupants of such associated spaces to egress through the manufacturing area with the increased exit access travel distance provided that the exit access travel distance within the associated areas does not exceed that specified in Table 1016.1 for the occupancy(s) under consideration.

Please do not be distracted by some of the larger exit access travel distance values contained in the proposed table. The longest allowance of 1,500 feet appears extreme compared to Table 1016.1 values. In reality, it only represents six minutes of travel time based on an assumed rate of travel of 250 feet per minute (*NFPA Life Safety Code Handbook* data), and it is only permitted in a building with a volume of over one hundred million cubic feet. Upon further examination, 71 percent of the cells of the proposed table require less than three minutes of exit access travel time for buildings having a volume of not less than 3.75 million cubic feet. The results of Boeing modeling runs would indicate that ceiling height is a major factor in the maintenance of occupant tenability during egress from a fire event. This proposal is limited to aircraft manufacturing facilities only. This is because of a high degree of occupant familiarity and the relatively low fuel loading compared with many other Group F-1 and S-1 occupancies.

In summary, the unique size of some aircraft manufacturing facilities inherently provides a tenable environment for building occupants as they travel to an exit. It is logical that spaces with higher ceilings provide for a greater level of occupant tenability than those with lower ceilings. Rather than arbitrarily selecting travel distance values based on former provisions or attempting an educated guess, The Boeing Company has conducted computer modeling in order to determine acceptable travel distances. Supporting data is available for review at <http://www.boeing.com/nosearch/tds/>. Approval of this proposal will acknowledge means of egress design issues associated with large area, high volume aircraft manufacturing spaces while providing a high degree of occupant safety during egress from such buildings.

Cost Impact: The code change proposal will not increase the cost of construction.

Public Hearing: Committee:	AS	AM	D
Assembly:	ASF	AMF	DF

ICCFILENAME:Keith-Wallace-E1-1016.3

E110-09/10

1017.5 (New) [IFC [B] 1017.5 (New)]

Proponent: Ali M. Fattah, City of San Diego, representing SD Area Chapter ICC Code Committee

Add new text as follows:

1017.5 (IFC [B] 1017.5) Aisles in other than Groups A, B and M. In other than Group A, B and M occupancies, the minimum clear aisle width shall be determined by Section 1005.1 for the occupant load served, but shall not be less than 36 inches (914 mm).

Reason: This proposed code change adds clarity and a requirement inadvertently omitted. There are currently no minimum aisle requirements for F, S, H, I, R occupancies. For example in a parking garage an access aisle may be through a space between two columns to get to the main drive aisle. Or between storage racks or shelving in a warehouse.

Cost Impact: The code change proposal will minimally increase the cost of construction.

Public Hearing: Committee:	AS	AM	D
Assembly:	ASF	AMF	DF

ICCFILENAME:Fattah-E1-1017.5

E111-09/10

1018.1 (IFC [B] 1018.1)

Proponent: Mark Blanke, PE, New York State Div. of Code Enforcement and Administration

Revise as follows:

1018.1 (IFC [B] 1018.1) Construction. Corridors shall be fire-resistance rated in accordance with Table 1018.1. The corridor walls required to be fire-resistance rated shall comply with Section 709 for fire partitions.

Exceptions:

1. A fire-resistance rating is not required for corridors in an occupancy in Group E where each room that is used for instruction has at least one door directly to the exterior and rooms for assembly purposes have at least one-half of the required means of egress doors opening directly to the exterior. Exterior doors specified in this exception are required to be at ground level.
2. A fire-resistance rating is not required for corridors contained within a dwelling or sleeping unit in an occupancy in Group R.
3. A fire-resistance rating is not required for corridors in open parking garages.
4. A fire-resistance rating is not required for corridors in an occupancy in Group B which is a space requiring only a single means of egress complying with Section 1015.1.
5. A fire-resistance rating is not required for corridors where the length of the corridor is less than 2.5 times the least width.

Reason: This proposed amendment provides a uniform application for corridor enclosure requirements and offers a design option to enlarge a corridor width in lieu of providing a fire resistance rating.

The IBC definition of a corridor does not readily establish when a space should be considered a room or a corridor. This is because it does not acknowledge narrowness or length as corridor characteristics commonly found in most dictionaries. The definition of a corridor is "an enclosed exit access component that defines and provides a path of egress travel to an exit." Any room is an enclosed exit access component that provides a path of egress to an exit. The room becomes a corridor when it actually defines a path to an exit. But the question is what room configuration defines a path to an exit where it becomes a corridor that should be subject to fire-resistance rating requirements. This proposed amendment provides a length-to-width ratio that more clearly and uniformly establishes this threshold.

The purpose of fire rating corridor enclosures is to protect occupants traveling in a confined space from the hazards of fire. The more the space is confined the greater the hazard, and by contrast, decreasing the confinement reduces the hazard. If a corridor width is increased, it begins to resemble a room where it becomes reasonable to eliminate the fire-resistance rating of the enclosure. As an example, a corridor measuring 3'x25' serving an occupant load of 40 in an unsprinklered Group B occupancy is required to have 1-hour fire-resistance rated enclosures with fire protection of door openings. Given the confined nature of this space, it is appropriate to require the necessary fire protection. However, if the corridor width were increased to 10 feet while maintaining its original length, the space becomes much less confined, less hazardous, and begins to resemble an adjoining or intervening room otherwise permitted without rated enclosures as part of an exit access. Some would argue that the enlarged space is no longer a corridor and not subject to the provisions of Section 1018.

The proposed amendment establishes a 2.5 length/width ratio as the transition for requiring fire-resistant rated corridor enclosures. This ratio was chosen because it is the same as that used in exception #3 of Section 1018.4 that would allow an unlimited dead end corridor where the length is less than 2.5 times the width. Given that the code has established this ratio as an appropriate exception to allow unlimited dead end corridors, it seems appropriate to use the same standard to corridor fire-resistance requirements.

Cost Impact: The code change proposal will not increase the cost of construction.

Public Hearing:	Committee:	AS	AM	D
	Assembly:	ASF	AMF	DF

ICCFILENAME:Blanke-E1-1018.1

E112-09/10

1018.1 (IFC [B] 1018.1)

Proponent: Homer Maiel, PE, CBO, City of San Jose, representing ICC Tri-Chapter (Peninsula, East Bay, Monterey Bay)

Revise as follows:

1018.1 (IFC [B] 1018.1) Construction. Corridors shall be fire-resistance rated in accordance with Table 1018.1. The corridor walls required to be fire-resistance rated shall comply with Section 709 for fire partitions.

Exceptions:

1. A fire-resistance rating is not required for corridors in an occupancy in Group E where each room that is used for instruction has at least one door opening directly to the exterior and rooms for assembly purposes have at least one-half of the required means of egress doors opening directly to the exterior. Exterior doors specified in this exception are required to be at ground level.
2. A fire-resistance rating is not required for corridors contained within a dwelling or sleeping unit in an occupancy in Group R.
3. A fire-resistance rating is not required for corridors in open parking garages.

4. A fire-resistance rating is not required for corridors in an occupancy in Group B which is a space requiring only a single means of egress complying with Section 1015.1.
5. Corridors adjacent to the exterior walls of buildings shall be permitted to have unprotected openings on the exterior wall where permitted by Table 705.8 and Table 602.

Reason: Since protected openings are only required where corridor walls are required to be fire-resistive construction, the exterior walls of buildings which also form a corridor wall need not be of fire-resistive construction, provided that the protection is not required based on Tables 705.8 and 602.

Cost Impact: The code change proposal will not increase the cost of construction.

Public Hearing: Committee: AS AM D
 Assembly: ASF AMF DF

ICCFILENAME:Maiei-E9-1018.1

E113-09/10

Table 1018.1 (IFC [B] Table 1018.1)

Proponent: Robert J Davidson, Code Consultant/Alan Shuman, President, representing the National Association of State Fire Marshals (NASFM): Thomas S. Zaremba, Roetzel & Andress, representing self

Revise as follows:

**TABLE 1018.1 (IFC [B] TABLE 1018.1)
 CORRIDOR FIRE-RESISTANCE RATING**

OCCUPANCY	OCCUPANT LOAD SERVED BY CORRIDOR	REQUIRED FIRE-RESISTANCE RATING (hours)	
		Without sprinkler system	With sprinkler system ^c
H-1, H-2, H-3	All	Not permitted	1
H-4, H-5	Greater than 30	Not permitted	1
A, B, E, F, M, S, U	Greater than 30	1	0
E	Greater than 30	1	1
R	Greater than 10	Not permitted	0.5
I-2 ^a , I-4	All	Not permitted	0
I-1, I-3	All	Not Permitted	1 ^b

- a. For requirements for occupancies in Group I-2. see Sections 407.2 and 407.3.
- b. For a reduction in the fire-resistance rating for occupancies in Group I-3, see Section 408.8.
- c. Buildings equipped throughout with an automatic sprinkler system in accordance with Section 901.3.1.1 or 903.3.1.2 where allowed.

Reason:

Davidson/Shuman – This code change was proposed by several parties in the last development cycle as E117-07/08. Although half the Committee supported its adoption, the Chair broke a tie vote in favor of a recommendation of disapproval. At the Final Action Hearings, the Committee’s recommendation was overturned, but a motion to “approve as submitted” failed to secure the 2/3 majority needed for adoption. The Membership voted 55% in favor of adoption.

There are good reasons that a solid majority of the Membership favors adopting this proposal. First, the E occupancies at issue represent structures built to house a dense population of children ranging from ages 4 through early teens. Group E occupancies typically have paper and other flammables hung from ceilings to floors throughout. Classrooms are filled with desks containing books, papers and other flammables. Science labs use chemicals and accelerants. Lunch rooms have stoves, ovens and trash cans spread throughout loaded with waste paper and other flammables. Theaters house clothing, wooden and cardboard props and paper banners strung from one end of the room to the other. Lockers contain books and hide things that are not easily monitored. Janitorial closets house cleaning solutions and solvents. Many Group E occupancies are multi-story buildings with classrooms on several floors.

Group E occupancies mix a high concentration of children with fuel loads on a daily basis. As budgets shrink, so do the number of adult supervisors. Our children are in schools because they are required to be there. We owe them a duty to ensure they are safe from the risk of fire while in school. We simply cannot wait for a catastrophe to protect children while at school.

Unfortunately the world of elementary, secondary and higher education learning has gone through tremendous changes in security measures undertaken, both operationally and hardware installations, due to the threat of violent acts committed against students and staff. Where we had educational facilities with highly effective fire drill evacuation procedures and actions during system activation, we now have written plans and training in place to ignore the activation of the fire alarm system if a “lockdown” has been declared because the activation of the fire alarm system may be a diversion to bring staff and students out into the open to serve as victims.

This is not a possible situation. This is a very real situation that occurs throughout the country in response to the acts of violence that have occurred at educational facilities. Though the exact procedure may vary site to site, the main premise of a “lockdown” is to gather staff and students into classrooms and offices and to lock the doors, preventing intruders from getting into the room and preventing staff and students from leaving the rooms until an all clear is announced. The staff and students are trained to ignore a fire alarm activation during a lockdown until they are ordered to evacuate after someone in authority, (could be a Principal or could be a Police Commander), makes a determination that the fire threat is real and that they must evacuate to survive the fire.

Because the students and staff will delay their evacuation while a fire is attacking the structure and potentially cutting off escape routes where corridors are not protected, this code change proposal will require all corridors serving an occupant load greater than 30 in group E educational occupancies to have 1 hour fire resistant rating except as allowed by Exception 1 to section 1018.1.

Exception 1 to Section 1018.1 is a legitimate exception for the one hour corridor fire resistant rating requirement, since it requires every classroom to have at least one door directly to the exterior and rooms used for assembly purposes have at least 1/2 of the required means of egress directly to the exterior as well. Under those conditions, there is no need for the students and other occupants to rely on exiting the building through the corridors since they can go directly to the exterior and move to a safe area of refuge. Once the announcement to evacuate occurs they can exit without being exposed to the fire threat potentially extended into the unprotected corridor.

However, if this is not the case, then the students, teachers, and other occupants of the educational occupancy must rely on the corridor system to exit safely from the building. In that case the paths of travel to get out of the building are restricted and the occupants may be exposed to the room of fire origin while trying to evacuate. Certainly, the basis for 1 hour fire resistive protection for corridors when the occupant load exceeds 30 is to provide for a reasonable level of protection for the occupants as they exit the building without having them unduly be exposed to a fire condition, water, and smoke which may impede their egress because they have delayed their evacuation due to a "lockdown".

It has been reported that there is an annual average of 14,700 fires in educational properties in the United States. The estimated average property loss from these fires is \$85 million per year, and caused approximately 100 injuries. The costs of bussing students to alternate facilities, the impact of double sessions in schools to accommodate displaced students, and the mental aspect of the children who fell victim to the fires is less than construction costs of a 1 hour fire resistant corridor.

Nearly half (49.7 %) of these fires were incendiary or suspicious in nature. Structure fires can start in a wide variety of different areas. During 1999-2001, 23% of the fire origins were in bathrooms/locker rooms, 13% started in the kitchen area, 7% in the classrooms, and another 7% started in corridors. Even more disturbing are findings indicating that injuries per school fires are higher than those of ALL non-residential structure fires. Certainly, the fact that more than 70% of fires occur between 0800 and 1600, the hours students are most likely to be in school, and 16% of fires occur between 1700 and 2400; 12% occur between 2400 and 0800 shows that the threat of a fire occurring while children are present is real.

Currently, the International Building Code (IBC) allows the 1-hour fire –resistance rated corridor to be omitted where the building is protected by an automatic sprinkler system. We don't believe that such a "trade-off" is appropriate, especially in an educational occupancy where there are large numbers of children at relatively high density who are placed at risk in a fire situation. We believe that due to the expanding use of "lockdown" procedures a balanced design approach to providing life safety in educational occupancies is prudent so that the 1-hour fire resistance rated corridors can work in conjunction with the automatic sprinkler system to assure the level of life safety for the building's occupants intended by the code.

Note that an I-3 occupancy, (correctional centers, detention centers, jails, prerelease centers, prisons, and reformatories), requires the corridors to have 1 hour fire-resistance ratings when the occupancy is protected by a fire suppression system, regardless of the number of occupants. When a "lockdown" occurs in a school the staff and students are prisoners. They are prohibited from leaving the rooms or areas of protection until given permission (ordered) to do so, or because they are being held hostage. For consistency purposes the staff and students in educational occupancies deserve the same level of protection we provide to inmates. A comparison to the other I groups where evacuation of the occupants may be delayed or prevented because they are incapable of self preservation is also appropriate and substantiates a need to increase the protection level for corridors in the education group occupancies since in the case of "lockdowns" the staff and students are prevented from taking self preservation actions when the fire alarm activates until authorized, (ordered), to evacuate after an undetermined delay in time.

Other points to consider are the construction modifications made due to high-profile events and fuel loads in our schools. Events as the Columbine High School shootings, the need of school security can sometimes conflict with the requirements of fire safety. For example, exits may be restricted for security reasons preventing escape should a fire occur. Today's structures are unquestionably safer, yet the contents of today's classrooms are more combustible. Evidence suggests that fires in schools can spread far more rapidly due to the fuel load in the school buildings.

An additional benefit of the 1-hour fire resistance rated corridor is that it can assist fire fighters and tactical response team members in doing their job by providing a protected means of access to the interior of the building where they can perform their search and rescue missions, as well as fire fighting operations, in relative safety. Fire resistant corridors provide fire fighters and tactical response team members with additional time to conduct their life safety operations more effectively and safely.

From an economic perspective, fires rank as a major national problem, and since no individual safety measure is reliable all of the time, fire protection should and must be redundant. We are concerned that the compounding effect of sprinkler trade-offs could lead to greater risk to the life safety of the building occupants, especially if combined with the reduction in or the elimination of the 1 hour fire resistance rated corridors providing access to the exits or exit stairwells in an occupancy that routinely has staff and students drill and respond in real events to ignore fire alarm system activations. Too much reliance on automatic sprinkler systems may not be wise where life safety is a key consideration. We strongly believe that a balanced approach to fire and life safety in buildings should be provided when a fire occurs.

Zaremba -This code change was proposed by several parties in the last development cycle. Although half the Committee supported its adoption, the Chair broke a tie vote resulting in a Committee recommendation of disapproval. At the Final Action Hearings, however, the Committee recommendation was overturned. Although a motion to "approve as submitted" received a favorable vote of 55% of the Membership, it did not receive the 2/3 majority needed for adoption.

A majority of the Membership had good reason to favor the adoption of this proposal. First, the E occupancies at issue represent structures built to house a dense population of children ranging from ages 4 through early teens. Group E occupancies typically have paper and other flammables hung from ceiling to floor on every wall. Classrooms are filled with desks containing books, papers and other flammables. Science labs use chemicals and accelerants. Lunch rooms have stoves, ovens and trash cans spread throughout, all loaded with waste paper and other flammables. Theaters house clothing, wooden and cardboard props and paper banners strung from one end of to the other. Lockers contain books and hide things that are not easily monitored. Many Group E occupancies are multi-story buildings with relatively long corridors between classrooms and exit discharges.

In short, Group E occupancies represent a daily mix of high occupancy loads, children and significant fuel loads. As budgets shrink, so do the number of adult supervisors. E occupancies should provide children with an environment redundant in fire safety protections.

Especially because large numbers of children would be at risk in the event of a fire, redundant fire protection systems is warranted without waiting for a catastrophic loss of life to provide the motivation for making this change. Sprinklered Group E occupancies with corridors serving occupant loads of more than 30 children should include 1-hour fire resistance rated corridor construction.

Cost Impact: The code change proposal will increase the cost of construction.

Public Hearing: Committee:	AS	AM	D
Assembly:	ASF	AMF	DF

ICCFILENAME:Zaremba-E2-Table 1018.1

E114-09/10

1018.1, 1018.1.1 (New) [IFC [B] 1018.1, 1018.1.1 (New)]

Proponent: Robert J Davidson, Code Consultant, Alan Shuman, President, representing the National Association of State Fire Marshals (NASFM); Thomas S. Zaremba, Roetzel & Andress representing self

Add new text as follows:

1018.1 (IFC [B] 1018.1) Construction. Corridors, other than those regulated by Section 1018.1.1, shall be fire-resistance rated in accordance with Table 1018.1. The corridor walls required to be fire-resistance rated shall comply with Section 709 for fire partitions.

Exceptions:

1. A fire-resistance rating is not required for corridors in an occupancy in Group E where each room that is used for instruction has at least one door opening directly to the exterior and rooms for assembly purposes have at least one-half of the required means of egress doors opening directly to the exterior. Exterior doors specified in this exception are required to be at ground level.
2. A fire-resistance rating is not required for corridors contained within a dwelling or sleeping unit in an occupancy in Group R.
3. A fire-resistance rating is not required for corridors in open parking garages.
4. A fire-resistance rating is not required for corridors in an occupancy in Group B which is a space requiring only a single means of egress complying with Section 1015.1.

**TABLE 1018.1 (IFC [B] TABLE 1018.1)
CORRIDOR FIRE-RESISTANCE RATING**

OCCUPANCY	OCCUPANT LOAD SERVED BY CORRIDOR	REQUIRED FIRE-RESISTANCE RATING (hours)	
		Without sprinkler system	With sprinkler system ^c
H-1, H-2, H-3	All	Not Permitted	1
H-4, H-5	Greater than 30	Not Permitted	1
A, B, E, F, M, S, U	Greater than 30	1	0
R	Greater than 10	Not Permitted	0.5
I-2 ^a , I-4	All	Not Permitted	0
I-1, I-3	All	Not Permitted	1 ^b

a. For requirements for occupancies in Group I-2, see Sections 407.2 and 407.3.

b. For a reduction in the fire-resistance rating for occupancies in Group I-3, see Section 408.8.

c. Buildings equipped throughout with an automatic sprinkler system in accordance with Section 903.3.1.1 or 903.3.1.2 where allowed.

1018.1.1 (IFC [B] 1018.1.1) Category III and IV Buildings in Hurricane-Prone and Seismic Areas. Corridors in all Category III and Category IV buildings as defined in Table 1604.5 shall have a fire resistance rating of 1-hour if located in hurricane-prone regions defined in Section 1609.2 or assigned to seismic design categories C, D, E or F in Section 1613.5.6.

Reason:

Davidson, Shuman - Category III buildings are defined in Table 1604.5 as those "that represent a substantial hazard to human life in the event of failure." They include, but are not limited to:

- Public assembly occupancies with occupant loads greater than 300,
- Elementary or secondary schools or day care facilities with occupant loads greater than 250,
- Adult education facilities with occupant loads greater than 500,
- Group I-2 occupancies with occupant loads greater than 50, and
- Group I-3 occupancies.

Category IV buildings are those which are designated as essential facilities. "Essential Facilities" are defined in section 1602.1 as "[b]uildings and other structures that are intended to remain operational in the event of extreme environmental loading from flood, wind, snow or earthquakes. These include, but are not limited to:

- Designated earthquake, hurricane or other emergency shelters,
- Designated emergency preparedness, communications and operations centers and other facilities required for emergency response, and
- Fire, rescue, ambulance and police stations and emergency vehicle garages.

In the face of impending natural disasters, residents regularly seek refuge in, or are evacuated from their homes to, Category III or IV buildings. At the same time, hurricanes and earthquakes regularly render roads impassable, often times cutting these evacuation shelters off from municipal and emergency medical, police and fire services. Even if these sites remain accessible by road, first responders may be unable to promptly respond when confronted with the wide spread devastations of a hurricane or earthquake.

Adopting this code change would ensure that redundant safety features, in the form of sprinklers and fire resistance rated corridors, are in place to ensure a safe evacuation of high occupancy buildings used as emergency shelters in hurricane and seismic areas.

Zaremba - Buildings and infrastructures can be severely damaged in hurricanes and earthquakes.

Category III buildings are those that represent a “substantial hazard to human life in the event of failure” and include buildings with high occupancy loads, for example, public assembly buildings with occupant loads greater than 300; elementary or secondary schools or day care facilities with occupant loads greater than 250; adult education facilities with occupant loads greater than 500; Group I-2 occupancies with occupant loads greater than 50; and Group I-3 occupancies.

Category IV buildings are specifically intended to provide shelter in natural catastrophes. These are “essential facilities,” defined in section 1602.1 as those intended to remain operational throughout a natural disaster. They include designated earthquake, hurricane or other emergency shelters; designated emergency preparedness, communications and operations and emergency response centers; and fire, rescue, ambulance and police stations and emergency vehicle garages.

Hurricanes and earthquakes can quickly interrupt utilities, including power, communications and water supplies, while slowing or prohibiting travel to and from these facilities. A fire in a Category III or IV building during or after a hurricane or seismic event could result in a significant loss of life when large concentrations of people, including first responders, or those suffering from disabilities, are forced to evacuate under circumstances where communications and sprinkler systems are inoperable and emergency fire and rescue services are inaccessible or unavailable. To ensure safe evacuations in the event of fire, this proposal would require Cat. III and IV buildings in hurricane prone and seismic areas to include 1-hour fire-resistance rated corridors.

Cost impact: The code change proposal will increase the cost of construction.

Public Hearing: Committee: AS AM D
 Assembly: ASF AMF DF

ICCFILENAME:Davidson-Shuman-E2-1018.1.1

E115–09/10

1018.2, Table 1018.2 (New) [IFC [B] 1018.2, Table 1018.2 (New)]

Proponent: John England, MCO, England Enterprises Inc., representing self

1. Revise as follows:

1018.2 (IFC [B] 1018.2) Corridor width. The minimum corridor width shall be as determined in Section 1005.1, but not less than specified in Table 1018.2 ~~but not less than 44 inches (1118 mm).~~

Exceptions:

1. ~~Twenty-four inches (610 mm) — For access to and utilization of electrical, mechanical or plumbing systems or equipment.~~
2. ~~Thirty-six inches (914 mm) — With a required occupant capacity of less than 50.~~
3. ~~Thirty-six inches (914 mm) — Within a dwelling unit.~~
4. ~~Seventy-two inches (1829 mm) — In Group E with a corridor having a required capacity of 100 or more.~~
5. ~~Seventy-two inches (1829 mm) — In corridors and areas serving gurney traffic in occupancies where patients receive outpatient medical care, which causes the patient to be not capable of self-preservation.~~
6. ~~Ninety-six inches (2438 mm) — In Group I-2 in areas where required for bed movement~~

2. Add new Table as follows:

Table 1018.2 (IFC [B] Table 1018.2)
MINIMUM CORRIDOR WIDTH

<u>Occupancy</u>	<u>Width (min)</u>
<u>Any facilities not listed below</u>	<u>44" (1118 mm)</u>
<u>Access to and utilization of mechanical, plumbing or electrical systems or equipment</u>	<u>24" (610 mm)</u>

Occupant load less than 50	36" (914 mm)
Within a dwelling unit	36" (914 mm)
Group E with occupant load of 100 or more	72" (1829 mm)
Group B or I-2 outpatient medical facilities where patients are moved on gurneys	72" (1829 mm)
Group I-2 in areas where care recipients are moved on beds	96" (2438 mm)

Reason: A table will make it easier to understand.

Cost Impact: The code change proposal will not increase the cost of construction.

Analysis: The terminology used in the text of the exceptions is different than the terminology used in the proposed table. A concern would be if this change in terminology change the original interpretation of these exceptions.

Public Hearing: Committee: AS AM D
Assembly: ASF AMF DF

ICCFILENAME:England-E1-1018.2

E116-09/10

1018.5 (IFC [B] 1018.5) (IMC [B] 601.2)

Proponent: Guy Tomberlin, Fairfax County, Virginia Plumbing and Mechanical Inspectors Association, representing VA Building and Code Officials

Revise as follows:

1018.5 (IFC [B] 1018.5) (IMC [B] 601.2) Air movement in egress elements. Corridors shall not serve as supply, return, exhaust, relief or ventilation air ducts.

Exceptions:

1. Use of a corridor as a source of makeup air for exhaust systems in rooms that open directly onto such corridors, including toilet rooms, bathrooms, dressing rooms, smoking lounges and janitor closets, shall be permitted, provided that each such corridor is directly supplied with ~~outdoor air~~ ventilation air at a rate greater than the rate of makeup air taken from the corridor.
2. Where located within a dwelling unit, the use of corridors for conveying return air shall not be prohibited.
3. Where located within tenant spaces of 1,000 square feet (93 m²) or less in area, utilization of corridors for conveying return air is permitted.
4. Incidental air movement from pressurized rooms within health care facilities, provided that the corridor is not the primary source of supply or return to the room.

Reason: It was not the original intent of this section to provide outdoor air to a corridor to be used as makeup air. This has now been clarified through the addition of new exhaust column found in IMC Table 403.3. If the intent were to use just outdoor air, only corridors served by 100% outdoor air systems would qualify for this exception or exhausting extremely large amounts of ventilation air.

For example: If a bathroom directly off a corridor is required to exhaust 150 cfm of "outdoor air". And, if the corridor is provided with a ventilation system that has 20% outdoor air, the exhaust rate for the bathroom would have to be increased to 750 cfm (150/0.20)

Cost Impact: The code change proposal will decrease the cost of construction.

Public Hearing: Committee: AS AM D
Assembly: ASF AMF DF

ICCFILENAME: TOMBERLIN-E1-1018.5

E117-09/10

1018.6 (IFC [B] 1018.6)

Proponent: Anne VonWeller, Murray City, representing the Utah Chapter of the International Code Council

Revise as follows:

1018.6 (IFC [B] 1018.6) Corridor continuity. Fire-resistance-rated corridors shall be continuous from the point of entry to an exit, and shall not be interrupted by intervening rooms. Where the path of egress travel within a fire-resistance-rated corridor to the exit includes travel along unenclosed exit access stairways or ramps, the fire resistance-rating shall be continuous for the length of the stairway or ramp and for the length of the connecting corridor on the adjacent floor leading to the exit.

Exception: Foyers, lobbies or reception rooms constructed as required for corridors shall not be construed as intervening rooms.

Reason: This change is offered to clarify how the fire-resistance of rating of a corridor is maintained from the corridor to an exit where an unenclosed exit access stairway or ramp is allowed and occurs along the path of egress travel.

Cost Impact: None.

Public Hearing: Committee:	AS	AM	D
Assembly:	ASF	AMF	DF

ICCFILENAME:Vonweller-E2-1018.6

E118–09/10

1020.1 (IFC [B] 1020.1)

Proponent: Homer Maiel, PE, CBO, City of San Jose, representing ICC Tri-Chapter (Peninsula, East Bay, Monterey Bay)

Revise as follows:

1020.1 (IFC [B] 1020.1) General. Exits shall comply with Section 1020 through 1026 and the applicable requirements of Sections 1003 through 1013. An exit shall not be used for any purpose that interferes with its function as a means of egress. Once a given level of exit protection is achieved, such level of protection shall not be reduced until arrival at the exit discharge.

Exception: A reduced level of exit protection is allowed at the level of exit discharge as permitted by the exceptions to Section 1027.1

Reason: The prohibition of a reduced level of exit protection within an exit as specified in last sentence in Section 1020.1 is permitted to be violated in specific cases. Two exceptions to Section 1027.1 allow certain interior spaces (e.g., a lobby or vestibule) located on the level of exit discharge to have less than two-hour protection from other adjacent interior spaces even though occupants may have previously been inside a two hour rated exit enclosure. The proposed exception to 1020.1 removes the contradiction between the last sentence of 1020.1 and those provisions contained in the exceptions to Section 1027.1 that explicitly permit a reduced level of protection while still inside the building.

Cost Impact: The code change proposal will not increase the cost of construction.

Public Hearing: Committee:	AS	AM	D
Assembly:	ASF	AMF	DF

ICCFILENAME:Maiel-E8-1020.1

E119–09/10

1021.1, 1021.1.3 (New) [IFC [B] 1021.1, 1021.1.3 (New)]

Proponent: Marshall Klein PE, representing Marshall A. Klein & Associates Inc.

1. Revise as follows:

1021.1 (IFC [B] 1021.1) Exits from stories. All spaces within each story shall have access to the minimum number of approved independent exits as specified in Table 1021.1 based on the occupant load of the story. For the purposes of this chapter, occupied roofs shall be provided with exits as required for stories.

Exceptions:

1. As modified by Section 403.15.3.
2. As modified by Section 1021.2.
3. Exit access stairways and ramps that comply with Exception 3 or 4 of Section 1016.1 shall be permitted to provide the minimum number of approved independent exits required by Table 1021.1 on each story.
4. ~~In Group R-2 and R-3 occupancies, one means of egress is permitted within and from individual dwelling units with a maximum occupant load of 20 where the dwelling unit is equipped throughout with an automatic sprinkler system in accordance with Section 903.3.1.1 or 903.3.1.2.~~
5. Within a story, rooms and spaces complying with Section 1015.1 with exits that discharge directly to the exterior at the level of exit discharge, are permitted to have one exit.

2. Add new text as follows:

1021.1.3 (IFC [B] 1021.1.3) Single-story or multi-story dwelling units. Individual single-story or multi-story dwelling units shall be permitted to have a single exit from the dwelling unit provided all of the following criteria are met:

1. The dwelling unit complies with Section 1015.1 as a space with one means of egress and
2. Either the exit from the dwelling unit is located at the level of exit discharge, or the exit access outside the dwelling unit's entrance door provides access to not less than two approved independent exits.

Exception: Single exits designed in accordance with Section 1021.2

(Renumber subsequent sections)

Reason: This code proposal is only clarifying the application of the single means of egress requirements out of an individual dwelling unit under the Code.

The two criteria that need to be met to have a single means of egress for a dwelling unit are already stated in various sections of the Code, but are not stated in a single location so that code users can quickly find, and apply them, to designs.

Criteria #1 provides the code user Code Section 1015.1 where the provisions for spaces with one exit, or exit access, are given. Also covered in Criteria #1 is existing Section 1014.3 Exception #4 (which is referenced in Section 1015.1(2)) which requires the common path of egress travel within the dwelling unit to be no more than 125', and existing Section 1015.1(1) Exception permits a single means of egress within a dwelling unit with a maximum occupant load of 20.

Criteria #2 provides the code user the code requirements for means of egress after the occupant has left the dwelling unit, i.e. the occupant is now in the exit discharge (which is the exterior of the building/dwelling unit), or the occupant is now in the common exit access component of a building. If the occupant is in the exit discharge, then according to the Code the occupant is considered to be in a safe environment that will lead to a publicway. If the occupant has left the dwelling unit and is not on the level of exit discharge, then the occupant is now continuing through the exit access portion of the building, and will require access to at least two exits from the point he/she walked out of the dwelling unit.

This code proposal references both single and multi-level dwelling units because existing Section 1022.1 Exception #3 permits the stairway(s) within the dwelling unit to be unenclosed.

The exception to this new Section 1021.1.3 is for the special "single exit" design criteria under the existing Section 1021.2, "Single exits".

Please note that the deletion of Exception #4 under Section 1021.1 is NOT intended to remove this exception under the Code. Under existing Section 1015.1 Exception #1's Exception is the same exception as in existing Section 1021.1 Exception #4 that is being proposed for deletion (See approved Code Proposal E115-06/07). Exception #4 is being incorporated into new Section 1021.1.3 under Criteria #1 which references existing Section 1015.1.. Leaving this same exception in existing Section 1021.1 may lead to user confusion on whether this exception would be applied differently under Section 1021.1 vs. Section 1021.1.3. The answer is no, so the redundancy is not needed if it will just cause confusion.

In summary, this proposed new Section 1021.1.3 provides a user friendly section under the minimum number of exits section to the other scattered sections of Code in Article 10 that relate to single exit criteria for dwelling units.

Cost Impact: The code change proposal will not increase the cost of construction.

Public Hearing: Committee:	AS	AM	D
Assembly:	ASF	AMF	DF

ICCFILENAME: KLEIN-E1-1021.1.3

E120-09/10

1021.1, Table 1021.1 (IFC [B] 1021.1, Table 1021.1)

Proponent: Dennis Richardson PE, dbr group inc. representing self

Revise as follows:

1021.1 (IFC [B] 1021.1) Exits from stories. All spaces within each *story* shall have access to the minimum number of *approved independent exits* as specified in Table 1021.1 based on the *occupant load* of the *story*. For the purposes of this chapter, occupied roofs shall be provided with *exits* as required for stories.

Exceptions:

1. As modified by Section 403.5.2.
2. As modified by Section 1021.2.
3. *Exit access stairways* and *ramps* that comply with Exception 3 or 4 of Section 1016.1 shall be permitted to provide the minimum number of *approved independent exits* required by Table 1021.1 on each *story*.
4. In Group R-2 and R-3 occupancies, one *means of egress* is permitted within and from individual dwelling units with a maximum *occupant load* of 20 where the dwelling unit is equipped throughout with an *automatic sprinkler system* in accordance with Section 903.3.1.1 or 903.3.1.2.
5. Within a *story*, rooms and spaces complying with Section 1015.1 with *exits* that discharge directly to the exterior at the *level of exit discharge*, are permitted to have one *exit*.
6. Exits serving specific spaces or areas need not be accessed by the remainder of the story when all of the following are met:
 - 6.1 The number of exits from the entire story complies with Table 1021.1;
 - 6.2 The access to exits from each individual space in the story complies with Section 1015.1; and
 - 6.3 All spaces within each portion of a story shall have access to the minimum number of approved independent exits as specified in Table 1021.1 based on the occupant load of that portion of the story.

**TABLE 1021.1 (IFC [B] TABLE 1021.1)
MINIMUM NUMBER OF EXITS FOR OCCUPANT LOAD**

OCCUPANT LOAD (persons per story, or portion thereof)	MINIMUM NUMBER OF EXITS (per story, or portion thereof)
1-500	2
501-1,000	3
More than 1,000	4

Reason: Code change E113 06/07 which was approved as modified removed the words “except as modified in Section 1015.1” from section 1019.1 of the 2006 IBC. This language was confusing and should have been revised because Section 1015.1, regulating exit and exit access from spaces, and Section 1019.1, regulating exits from stories, referred back and forth to each other.

Even though this language was confusing, it did provide some relief from the provisions of 1019.1 which stated “All rooms and spaces within each story shall be provided with and have access to the minimum number of approved independent exits required by Table 1019.1 based on the occupant load of the story...”

It is simply not possible nor is it always necessary with a number of building configurations to provide access to all required exits from all portions of a story (see attached examples). This is true in cases where one or more of the required exits are located independently within a tenant space such as an open office space, large assembly tenant or other portion of the building that is not open for access to all of the other occupants of the building.

This code change proposal provides an exception which allows exits serving a specific area or portion of a building to not be accessible to all other portions of the building so long as:

- the overall number of exits are provided from the story as required by Table 1021.1,
- access to exits from individual spaces comply with Section 1015.1, and
- all spaces within each portion of a story shall have access to the minimum number of approved independent exits as specified in Table 1021.1 based on the occupant load of that portion of the story

The column headings of Table 1021.1 are also revised to acknowledge the number of exits required could also apply to a portion of a story as indicated in the proposed exception.

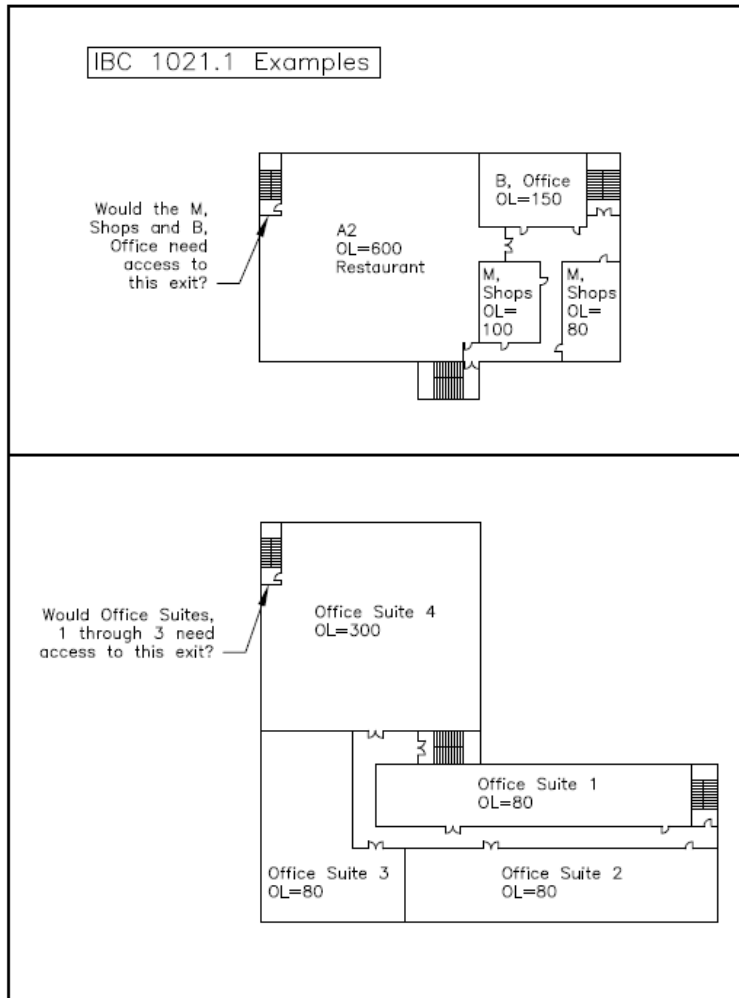

Cost Impact: This proposed code change will save cost of construction by creating an exception which clarifies the requirements of E113-06/07 which (depending on how interpreted) could cause the loss of floor space and construction of corridors or other modifications to connect all areas of a story with all exits including those which may be located in a specific area or portion of the story.

Public Hearing: Committee: AS AM D
 Assembly: ASF AMF DF

ICCFILENAME:Richardson-E1-1021.1

E121-09/10

1021.2, Table 1021.2, Table 1021.2(1) (New); [IFC [B] 1021.2, Table 1021.2, Table 1021.2(1) (New)]

Proponent: Wayne R. Jewell, CBO, Department of Building and Safety Engineering, City of Southfield and Sam Dorchen, representing Martin Associates, Inc.

1. Revise as follows:

1021.2 (IFC [B] 1021.2) Single exits. ~~Only one exit~~ Single exits shall be ~~required~~ permitted from Group R-3 occupancy buildings, Group R-2 dwelling units as indicated in Table 1021.2(1) or from stories of other buildings as indicated in Table 1021.2(2). Occupancies shall be permitted to have a single exit ~~in buildings when~~ otherwise required to have more than one exit if the areas served by the single exit ~~do~~ does not exceed the limitations of Tables 1021.2(1) or 1021.2(2). Mixed occupancies shall be permitted to be served by single exits provided each individual occupancy complies with the applicable requirements of Tables 1021.2(1) or 1021.2(2) for that occupancy. Where applicable, cumulative occupant loads from adjacent occupancies shall be considered in accordance with the provisions of Section 1004.1. ~~Basements~~ A basement provided with a single exit shall not be located more than one story below grade plane.

2. Add new Table as follows:

**TABLE 1021.2(1) (IFC [B] TABLE 1021.1(1))
SINGLE EXITS FOR R-2 OCCUPANCIES**

<u>STORY</u>	<u>OCCUPANCY</u>	<u>MAXIMUM NUMBER OF DWELLING UNITS PER FLOOR SERVED BY A SINGLE EXIT AND TRAVEL DISTANCE TO THE EXIT</u>
<u>Basement, first, second or third story</u>	<u>R-2^a</u>	<u>4 dwelling units and 125 feet travel distance</u>

For SI: 1 foot = 3048 mm.

a. Buildings classified as Group R-2 equipped throughout with an automatic sprinkler system in accordance with Section 903.3.1.1 or 903.3.1.2 and provided with emergency escape and rescue openings in accordance with Section 1029.

3. Revise as follows:

**TABLE 1021.2(2) (IFC [B] TABLE 1021.1(2))
STORIES WITH ONE EXIT SINGLE EXITS FOR OTHER OCCUPANCIES**

<u>STORY</u>	<u>OCCUPANCY</u>	<u>MAXIMUM OCCUPANTS (OR DWELLING UNITS) PER FLOOR AND TRAVEL DISTANCE TO THE EXIT</u>
First story or basement	A, B ^d , E ^e , F ^d , M, U, S ^d	49 occupants and 75 feet travel distance
	H-2, H-3	3 occupants and 25 feet travel distance
	H-4, H-5, I, R-1, R-2 ^{c,f} , R-4	10 occupants and 75 feet travel distance
	S ^a	29 occupants and 100 feet travel distance
Second story	B ^b , F, M, S ^a	29 occupants and 75 feet travel distance
	R-2	4 dwelling units and 50 feet travel distance
Third story	R-2 ^e	4 dwelling units and 50 feet travel distance

For SI: 1 foot = 3048 mm.

- a. For the required number of exits for parking structures, see Section 1021.1.1.
- b. For the required number of exits for air traffic control towers, see Section 412.3.
- c. Buildings classified as Group R-2 equipped throughout with an automatic sprinkler system in accordance with Section 903.3.1.1 or 903.3.1.2 and provided with emergency escape and rescue openings in accordance with Section 1029.
- d. Group B, F and S Occupancies in buildings equipped throughout with an automatic sprinkler system in accordance with Section 903.3.1.1 shall have a maximum travel distance of 100 feet.
- e. Day care occupancies shall have a maximum occupant load of 10.
- f. This Table is used for R-2 occupancies consisting of sleeping units. For R-2 occupancies consisting of dwelling units, use Table 1021.2(1).

Reason: This proposal is intended to follow up on Code Proposals E136-06/07 and E127-07/08 approved in the past 2 code cycles to clarify the application of single exit requirements under Section 1021.2, "Single exits", and Section 1015.1, "Exits or exit access doorways from spaces".

The revisions to Table 1021.2 splitting the Table into two Tables addresses changes to the Code dealing with the common path of travel for sprinklered R-2 occupancies that consists of dwelling units now required by the code to be sprinklered and not considered in original drafting of Table 1021.2 in the first edition of the IBC. Section 1014.3 Exception #4 of the current code permits up to 125' common path of travel to an exit in sprinklered R-2 occupancies. This proposed revision to Table 1021.2 would be consistent with that requirement. The existing Table has been clarified to apply to the R-1, R-2 and R-4 occupancies that consists of sleeping units, and clarified not to be applicable to R-3 which have been, and continue to be, permitted to have a single exit based on the text in Section 1021.2.

The original Table 1021.2 was placed in the 2000 edition of the Code when R-2 occupancies were not required to be sprinklered and the original travel distance numbers in Table 1021.2 were based on the non-sprinklered requirements. From a life safety aspect, the application of this revision would be equal to, if not considered better than; the presently permitted means of egress for a two exit R-2 occupancy with a typical exit access corridor and exit stairway at each end. The current code will allow a common path of travel of 125' and a total maximum travel distance to one of the exits of 250' (Table 1016.1). This code proposal would reasonably permit multiple groups of 4 dwelling units on a story as long as the design complies with the limitation of 125 feet of travel distance to a single exit provided it complies with the height and area limitations in Chapter 5 and Table 503. For the single exit provisions under this code proposal, the maximum travel distance permitted would be 50% less than presently permitted for a 2 exit R-2 building. The dwelling units' horizontal and vertical separations and stair enclosure requirements are the same regardless of the number of exits. The single exit provisions would still retain the emergency window requirement (Footnote "c" under the existing Table 1021.2 which would become Footnote "a" under the new Table 1021.2(1)) that is not required for a 2 exit R-2 building.

Cost Impact: The code change proposal will not increase the cost of construction.

Public Hearing: Committee:	AS	AM	D
Assembly:	ASF	AMF	DF

ICCFILENAME:Jewell-Dorchen-E1-1019.2

E122-09/10 1021.2 (IFC [B] 1021.2); R311.4

Proponent: Christine Reed and Stuart Tom, P.E., CBO, representing the California Fire Chiefs Association and the Los Angeles Basin Chapter, ICC; Jonathan C. Siu, representing City of Seattle, Department of Planning and Development

THIS IS A 2 PART CODE CHANGE. PART I WILL BE HEARD BY THE IBC MEANS OF EGRESS COMMITTEE. PART II WILL BE HEARD BY THE IRC BUILDING/ENERGY COMMITTEE. SEE THE TENTATIVE HEARING ORDERS FOR THESE COMMITTEES.

PART I – IBC MEANS OF EGRESS

Revise as follows:

1021.2 (IFC [B] 1021.2) Single exits. ~~Only one exit shall be required from Group R-3 occupancy buildings or from stories of other buildings as indicated in Table 1021.2.~~ Occupancies shall be permitted to have a single exit in buildings otherwise required to have more than one exit if the areas served by the single exit do not exceed the limitations of Table 1021.2. Mixed occupancies shall be permitted to be served by single exits provided each individual occupancy complies with the applicable requirements of Table 1021.2 for that occupancy. Where applicable, cumulative occupant loads from adjacent occupancies shall be considered in accordance with the provisions of Section 1004.1. Basements with a single exit shall not be located more than one story below grade plane.

PART II – IRC BUILDING/ENERGY

Revise as follows:

R311.4 Vertical egress. Egress from habitable levels including habitable attics and basements not provided with an egress door in accordance with Section R311.2 shall be by a one or more ramps in accordance with Section R311.8 or a one or more stairways in accordance with Section R311.7 or both. Habitable levels larger than 1,000 square feet (92.9 m²) located more than one story above or below an egress door shall be provided with not less than two means of egress.

Reason:

PART I –Section 1015.1 and Section 1021.1 both contain identical, very specific, exception language that allows Group R-3 occupancies to be permitted with one means of egress provided the occupant load is limited to a maximum of 20 and the dwelling unit is equipped throughout with an automatic sprinkler system in accordance with Section 903.3.1.1 or 903.3.1.2. As currently written, Section 1021.2 creates two (2) potential conflicts.

In one case, a potential conflict arises if the stricken sentence remains because of the reference "... as indicated in Table 1021.2". Table 1021.2 limits the number of occupants on the first story or basement of Group R occupancies to a maximum of 10 and a maximum travel distance of 75 feet. This conflict would result in the severe limitation of the size of 1-story Group R-3 occupancies with one means of egress to only 2,000 square feet, which is contrary to Sections 1015.1 and 1021.1 which allow up to 4,000 square feet in buildings equipped throughout with an automatic sprinkler system.

In the second case, a potential conflict arises if the stricken sentence remains because some readers might ignore the reference "... as indicated in Table 1021.2" and provide only one means of egress for Group R-3 occupancy buildings regardless of size. This would be in conflict with Sections 1015.1 and 1021.1 which impose a size limitation of 4,000 square feet based upon the maximum occupant load limit of 20, considering the occupant load factor of 200 square feet per occupant as indicated in Table 1004.1.1.

This proposal eliminates a confusing sentence within Section 1021.2, that is currently in conflict with Sections 1015.1 and 1021.1, thereby making all three sections consistent.

PART II –The IRC fails to address the fact that a single exit may not be sufficient for every R-3 occupancy One- or Two- Family Dwelling. While a single exit may be suitable for most dwellings, the same cannot be said of all dwellings. The IRC establishes the standards that will also apply to very large dwellings and dwellings constructed on steep lots, where egress design becomes more critical.

In comparison, the IBC addresses the need for a second means of egress through Sections IBC 1015.1 and IBC 1021.1. Both of these provisions will require a second means of egress from a Group R-3 occupancy if the occupant load exceeds 20 persons. Furthermore, since the IBC utilizes the 3-part means of egress design concept, Group R-3 occupancies regulated by the IBC would be required to have both means of egress comply with all applicable provisions of IBC Chapter 10.

Since the IRC does not utilize the 3-part means of egress concept nor the occupant load concept, it is not practical to use the same approach as the IBC in establishing whether a second means of egress is required in R-3 occupancies up to 3-stories in height. Furthermore, the need for a second means of egress is most critical on floors that are located more than one story above or below an egress door. This proposal does not require a second means of egress from 1- or 2- story Group R-3 occupancies because the length of vertical egress travel is inherently limited to a

maximum of one story in such buildings. This proposal will only require a second means of egress from habitable levels that are located more than one level above or below the egress door, and only if such levels exceed 1,000 square feet in area. Egress from such occupied floor levels becomes more critical because of the combination of increased vertical egress travel combined with the increased travel distance within a large floor area exceeding 1,000 square feet.

The IRC also fails to adequately address egress from Group R-3 occupancy dwellings constructed on steep hillside lots, especially lots located on the down-slope side of a street. Many jurisdictions throughout the country have steep hillside residential areas, where it is common to construct homes on the down-slope side of a street with the topmost floor located at street level and two additional floors located below street level. Often such down-slope lots are so steep that there is no usable rear yard. Consequently, homes constructed on such steep terrain typically do not have a rear door (that could serve as a second means of egress), because a door that leads to a steep and unusable rear yard is not likely to be installed. This proposal would require such occupied levels that are greater than 1,000 square feet in area to be provided with a second means of egress.

This code change proposal will not affect the majority of Group R-3 occupancy One- and Two- Family Dwellings regulated by the IRC.

Cost Impact: The code change proposal will not increase the cost of construction.

PART I – IBC MEANS OF EGRESS

Public Hearing: Committee:	AS	AM	D
Assembly:	ASF	AMF	DF

PART II – IRC BUILDING/ENERGY

Public Hearing: Committee:	AS	AM	D
Assembly:	ASF	AMF	DF

ICCFILENAME:tom-reed-siu-E1-1021.2

E123–09/10

1021.2 (IFC [B] 1021.2)

Proponent: Maureen Traxler representing City of Seattle, representing Seattle Dept of Planning & Development

Revise as follows:

1021.2 (IFC [B] 1021.2) Single exits. Only one exit shall be required from Group R-3 occupancy buildings or from stories of other buildings as indicated in Table 1021.2. Occupancies shall be permitted to have a single exit in buildings otherwise required to have more than one exit if the areas served by the single exit do not exceed the limitations of Table 1021.2. ~~Mixed occupancies shall be permitted to be served by single exits provided each individual occupancy complies with the applicable requirements of Table 1021.2 for that occupancy. Where applicable, cumulative occupant loads from adjacent occupancies shall be considered in accordance with the provisions of Section 1004.1.~~ Basements with a single exit shall not be located more than one story below grade plane.

Mixed occupancies shall be permitted to be served by single exits provided each individual occupancy complies with the applicable requirements of Table 1021.2 for that occupancy. In each story of a mixed occupancy building, the maximum number of occupants served by a single exit shall be such that the sum of the ratios of the calculated number of occupants of the space divided by the allowable number of occupants for each occupancy shall not exceed one.

Reason: As written, the provision would allow a single exit from a mixed occupancy story with as much as twice the occupant load allowed for a single occupancy story. For example, if on the second story of a building there are two tenant spaces, one is a B and one is an M, the B has 28 occupants and the M has 28 occupants. Both tenant spaces have a single door to a single exit stairway. Each of these occupancies complies with the limits of Table 1021.2, but cumulatively there are now 56 people using a single exit. The only way to prevent this substantial expansion of the number of occupants relying on a single exit, is to use a 'unity' formula that allows a calculation to see if the number of occupants is reasonable. This proposal moves the sentences regarding mixed occupancy out of the first paragraph and places them in their own paragraph. The new third sentence is added establishing a unity formula for mixed occupancies sharing the same single exit. This is based on the provision in Section 508.4.2 used to determine the allowable area of a separated mixed occupancy building. Finally, this will work in conjunction with the concept of a single story multiple tenant building where each tenant space has its own exterior exit. If someone chooses to have 2 tenant spaces of different occupancies share the same exit, then this added sentence would apply. But if that is too restrictive, they can always put in individual exits from each space.

Cost Impact: The code change proposal will not increase the cost of construction.

Public Hearing: Committee:	AS	AM	D
Assembly:	ASF	AMF	DF

ICCFILENAME:Traxler-E3-1021.2

E124–09/10

1022.3, 1022.4 (IFC [B] 1022.3, 1022.4)

Proponent: Gregory R. Keith, Professional heuristic Development, representing The Boeing Company

Revise as follows:

1022.3 (IFC [B] 1022.3) Openings and penetrations. Exit enclosure opening protectives shall be in accordance with the requirements of Section 715.

Openings in exit enclosures other than unprotected exterior openings shall be limited to those necessary for exit access to the enclosure from normally occupied spaces and for egress from the enclosure. There shall be no communicating openings, whether protected or not, between adjacent exit enclosures.

Elevators shall not open into an exit enclosure.

1022.4 (IFC [B] 1022.4) Penetrations. Penetrations into and ~~openings~~ through an exit enclosure are prohibited except for ~~required exit doors~~, equipment and duct work necessary for independent pressurization, sprinkler piping, standpipes, electrical raceway for fire department communication and electrical raceway serving the exit enclosure and terminating at a steel box not exceeding 16 square inches (0.010 m²). Such penetrations shall be protected in accordance with Section 713.

There shall be no penetrations ~~or communicating openings~~, whether protected or not, between adjacent exit enclosures.

Reason: The current title of Section 1022.3 is somewhat misleading in that it references “penetrations.” No provisions in Section 1022.3 apply to penetrations and there are no cross-references to Section 713. Section 1022.4, however, does address the penetration provisions applicable to exit enclosures. Technical references to openings in Section 1022.4 have either been removed or relocated to Section 1022.3. For instance, the reference to “required exit doors” in the first sentence has been eliminated because that concern is addressed in the second paragraph of Section 1022.3 that limits openings into an exit enclosure to those necessary for egress. Approval of this proposal will reduce confusion and assist users in the correct identification of applicable exit enclosure opening and penetration requirements.

Cost Impact: The code change proposal will not increase the cost of construction.

Public Hearing: Committee:	AS	AM	D
Assembly:	ASF	AMF	DF

ICCFILENAME:Keith-E8-1022.3

E125–09/10

1022.3 (IFC [B] 1022.3)

Proponent: Homer Maiel, PE, CBO, City of San Jose, representing ICC Tri-Chapter (Peninsula, East Bay, Monterey Bay)

Revise as follows:

1022.3 (IFC [B] 1022.3) Openings and penetrations. Exit enclosure opening protectives shall be in accordance with the requirements of Section 715.

Openings in exit enclosures other than unprotected exterior openings shall be limited to those ~~necessary~~ required for exit access to the enclosure from normally occupied spaces and for egress from the enclosure.

Exception: Protected openings shall be permitted in exit enclosure at the level of exit discharge in accordance with Section 715.

Elevators shall not open into an exit enclosure.

Reasons: The exception is to allow openings from ground level lobbies into exit enclosures. This opening may not be necessary for exit access from the lobby. However, the way the code language is, only openings “necessary” for exit access can open into exit enclosure. This exception will allow any opening, necessary or otherwise, at the exit discharge, to open into exit enclosure. The word “necessary” could be construed as subjective. However, the word “required” is more definitive and has been used in the code more consistently.

Cost Impact: The code change proposal will not increase the cost of construction.

Public Hearing: Committee:	AS	AM	D
Assembly:	ASF	AMF	DF

ICCFILENAME:Maiei-E7-1022.3

E126-09/10

1022.4, 1023.6 (IFC [B] 1022.4, 1023.6)

Proponent: Matthew Davy, PE, Schirmer Engineering Corporation, representing self

Revise as follows:

1022.4 (IFC [B] 1022.4) Penetrations. Penetrations into and openings through an exit enclosure are prohibited except for required exit doors, equipment and ductwork necessary for independent ventilation or pressurization, sprinkler piping, standpipes, electrical raceway for fire department communication systems and electrical raceway serving the exit enclosure and terminating at a steel box not exceeding 16 square inches (0.010 m²). Such penetrations shall be protected in accordance with Section 713. There shall be no penetrations or communication openings, whether protected or not, between adjacent exit enclosures.

Exception: Membrane penetrations shall be permitted on the outside of the exit enclosure. Such penetrations shall be protected in accordance with Section 713.3.2.

1023.6 (IFC [B] 1023.6) Penetrations. Penetrations into and openings through an exit passageway are prohibited except for required exit doors, equipment and ductwork necessary for independent pressurization, sprinkler piping, standpipes, electrical raceway for fire department communication and electrical raceway serving the exit passageway and terminating at a steel box not exceeding 16 square inches (0.010m²). Such penetrations shall be protected in accordance with Section 713. There shall be no penetrations or communicating openings, whether protected or not, between adjacent exit passageways.

Exception: Membrane penetrations shall be permitted on the outside of the exit passageway. Such penetrations shall be protected in accordance with Section 713.3.2.

Reason: The purpose of Sections 1022.4 and 1023.6 is to limit through penetrations into an exit enclosure or exit passageway; however, membrane penetrations should be permitted on the outside of the exit enclosure or exit passageway. As currently written, a pull station next to a door into the stair, fire hose cabinets, fire extinguisher cabinets, request-to-exit devices related to access control locks, notification appliances, etc., are not permitted on the outside of the exit enclosure. This exceptions needs to clarify the intent of Sections 1022.4 and 1023.6.

Cost Impact: The code change proposal will not increase the cost of construction

Public Hearing: Committee:	AS	AM	D
Assembly:	ASF	AMF	DF

ICCFILENAME:Davy-E1-1023.5

E127-09/10

1022.8 (IFC [B] 1022.8)

Proponent: Manny Muniz, California Deputy State Fire Marshal (Ret.), representing self

Revise as follows:

1022.8 (IFC [B] 1022.8) Floor Stairway identification signs. A sign shall be provided at each floor landing in exit enclosures connecting more than three stories designating the floor level, the terminus of the top and bottom of the exit enclosure and the identification of the stair or ramp. The signage shall also state the story of, and the direction to, the exit discharge and the availability of roof access from the enclosure for the fire department. The sign shall be located 5 feet (1524 mm) above the floor landing in a position that is readily visible when the doors are in the open and closed positions. ~~Floor level identification~~ In addition to the stairway identification sign, a floor level signs in tactile-raised characters and braille complying with ICC A117.1 shall be located at each floor level landing adjacent to the door leading from the enclosure into the corridor to identify the floor level.

1022.8.1 (IFC [B] 1022.8.1) Signage requirements. Stairway identification signs shall comply with all of the following requirements:

1. The signs shall be a minimum size of 18 inches (457 mm) by 12 inches (305 mm).
2. The letters designating the identification of the stair enclosure shall be a minimum of 1 1/2 inches (38 mm) in height.
3. The number designating the floor level shall be a minimum of 5 inches (127 mm) in height and located in the center of the sign.
4. All other lettering and numbers shall be a minimum of 1 inch (25 mm) in height.
5. Characters and their background shall have a nonglare finish. Characters shall contrast with their background, with either light characters on a dark background or dark characters on a light background.
6. When signs required by Section 1022.8 are installed in interior exit enclosures of buildings subject to Section 1024, the signs shall be made of the same materials as required by Section 1024.4.

Reason: Sections 1022.8 and 1022.8.1 contain three (3) different sign names. "Floor identification signs" in the title of Section 1022.8, "Floor level identifications signs" in the fourth sentence of Section 1022.8 and "Stairway identification signs" in the first sentence of Section 1022.8.1". The actual intent of this section is that there be two signs, one for the sight-impaired and one for people who can read signs. The first clarification is to use the term "stairway identification sign" as found in Section 1022.8.1. This will clarify what the sign should be called and will be consistent with the NFPA 101 Life Safety Code description of this sign. The second clarification is to make it clear that in addition to the stairway identification sign, a floor level sign in raised characters and braille complying with ICC A117.1 shall be located at each floor level landing adjacent to the door leading from the enclosure into the corridor to identify the floor level.

Cost Impact: The code change proposal will not increase the cost of construction.

Public Hearing:	Committee:	AS	AM	D
	Assembly:	ASF	AMF	DF

ICCFILENAME: Muniz-E2-1022.8

E128-09/10

1022.9 (IFC [B] 1022.9)

Proponent: Maureen Traxler representing City of Seattle, representing Seattle Dept of Planning & Development

Revise as follows:

1022.9 (IFC [B] 1022.9) Smokeproof enclosures and pressurized stairways. ~~In buildings~~ Where required by Sections 403.5.4 or 405.7.2 to comply with Section 403 or 405, each of the exit enclosures serving a story with a floor surface located more than 75 feet (22 860 mm) above the lowest level of fire department vehicle access or more than 30 feet (9144 mm) below the finished floor of a level of exit discharge serving such stories shall be smokeproof enclosures or pressurized stairways in accordance with Section 909.20.

Reason: As written, this provision combines the high-rise and underground building requirements, thus making them unclear. It could be mistakenly read that in a high-rise building, stair enclosures serving parking garage stories more than 30 feet below the level of exit discharge and meeting the exceptions of 405.1 would need to be smokeproof enclosures or pressurized stairways, and that is not the intent of the code. This proposal removes the language that describes which exit enclosures need to be smokeproof or pressurized and directly references the high-rise and underground building sections instead (Sections 403.5.4 and 405.7.2).

Cost Impact: The code change proposal will not increase the cost of construction.

Public Hearing:	Committee:	AS	AM	D
	Assembly:	ASF	AMF	DF

ICCFILENAME: Traxler-E4-1022.9

E129-09/10

1023.3 (IFC [B] 1023.3)

Proponent: Michael DiMascio, Arup, representing self

Revise as follows:

1023.3 (IFC [B] 1023.3) Construction. Exit passageway enclosures shall have walls, floors and ceilings of not less than 1-hour fire-resistance rating, and not less than that required for any connecting exit enclosure. When acting as a horizontal continuation of an exit enclosure on the level of exit discharge, the fire-resistance rating of the exit

passageway shall not be less than the rating required for the exit enclosure. Exit passageways shall be constructed as fire barriers in accordance with Section 707 or horizontal assemblies constructed in accordance with Section 712, or both.

Reason: This amendment is primarily intended as clarification. The present wording uses the term "any connecting exit enclosure". This has been interpreted to require a 2-hr exit passageway on a floor, other than the level of exit discharge, even when the exit passageway; (1) only provides access to a 2-hr vertical exit enclosure, which in turn continues to exit discharge, (2) only serves the floor on which it is located and (3) is separated from the vertical exit enclosure by 2-hr rated construction and the required opening protectives. This exit passageway is not a "continuation" of the vertical exit enclosure. It provides access to the vertical exit enclosure and is properly separated from the vertical exit enclosure. The level of protection provided is commensurate with the hazard, since the exit passageway is only protecting occupants from the hazards on the floor they are exiting. Whereas the vertical exit enclosure provides protection from the hazards on all floors it connects. In fact the code only requires a 1 hour rated vertical exit enclosure when the enclosure connects three floors or less.

This amendment provides needed clarification to the level of protection intended.

Cost Impact: The code change proposal will not increase the cost of construction.

Public Hearing:	Committee:	AS	AM	D
	Assembly:	ASF	AMF	DF

ICCFILENAME:Dimascio-E1-1023.3

E130-09/10

1002.1, 1023.4 (IFC [B] 1002.1, 1023.4)

Proponent: Michael DiMascio, Arup; representing self

Revise as follows:

1002.1 (IFC [B] 1002.1) Definitions. The following words and terms shall, for the purposes of this chapter and as used elsewhere in this code, have the meanings shown herein.

EXIT PASSAGEWAY. An exit component that is separated from other interior spaces of a building or structure by fire-resistance-rated construction and opening protectives, and provides for a protected path of egress travel in a horizontal direction to an exit or an exit discharge ~~or the public way.~~

1023.4 (IFC [B] 1023.4) Termination. Exit passageways on the level of exit discharge shall terminate at an exit discharge ~~or a public way.~~ Exit passageways on other levels shall terminate at an exit.

Reason: This amendments are primarily intended as clarification. The present wording does not define the use of exit passageways on levels other than the level of exit discharge. This means it does not address the use of exit passageways in malls and on upper and lower floors in buildings with large floor plates. In malls, exit passageways are frequently used between the mall itself and the vertical exit enclosure. (See Section 402.4.5 and 402.4.6) Using exit passageways on levels other than the level of exit discharge is a common practice where the travel distance to the vertical exit enclosure exceeds the allowable travel distance. The removal of the term, "or a public way" is for consistency. Based on the definition of means-of-egress, you must pass through an exit discharge before you reach a public way. Since the exit passageway is an extension of the exit enclosure, it must end at an exit discharge when located on the level of exit discharge.

This amendment provides needed clarification as to when the exit passageway must terminate at an exit discharge and clarifies it would not end at a public way.

Cost Impact: The code change proposal will not increase the cost of construction.

Public Hearing:	Committee:	AS	AM	D
	Assembly:	ASF	AMF	DF

ICCFILENAME:Dimascio-E2-1023.4

E131-09/10

1024.4 (IFC [B] 1024.4)

Proponent: Lee C. DeVito, PE, FIREPRO Incorporated, representing self

Revise as follows:

1024.4 (IFC [B] 1024.4) ~~Self-luminous and photoluminescent~~ Luminescent materials. Luminous egress path markings shall be permitted to be made of any material, including paint, ~~provided that an electrical charge is not required to maintain the required luminance.~~ Such materials shall include, but are not limited to, self-luminous materials ~~and photoluminescent materials~~ and electroluminescent materials. Materials shall comply with either:

1. UL 1994; or
2. ASTM E 2072, except that the charging source shall be 1 foot-candle (11 lux) of fluorescent illumination for 60 minutes, and the minimum luminance shall be 30 millicandelas per square meter at 10 minutes and 5 millicandelas per square meter after 90 minutes.

Reason: Electrical systems provide the building management with more flexibility with the operation of the exit path marking systems.

Electrical systems do not need backup lighting which will allow building managers to control lighting. Furthermore, energy savings and Green/LEEDS requirements (for example thru the use of motion sensor lighting) may be further achieved with electroluminescent materials, as separate, continuously operational light sources are not required for charging purposes. A later section of this code, 1024.5 Illumination, requires means of egress illumination for photoluminescent exit path markings is required for at least 60 minutes prior to periods when the building is occupied. Electroluminescent exit path markings would not require this.

Electrical systems can be operated at any time as they have available power and they are protected with battery standby support. Therefore, the building management can utilize the electrical systems when ever there is an alarm activity or other situation in the building, whether the building power is available or not. Self luminous and photoluminescent materials only provide lighting when the background lighting is limited.

Electrical systems are supervised so the building management will know that there is a problem. Self-luminous materials and photoluminescent materials are not supervised, so they can be damaged or removed and no one is notified until a manual check is performed on the system. Whereas the systems are required in some high-rise buildings manual inspection will be time consuming and possibly burdensome, which may mean that self luminous or photoluminescent systems may not be inspected.

The building management can utilize the flexibility of electrical systems to provide further information on the availability or disruption of an egress path.

Cost Impact: The code change proposal will not increase the cost of construction.

Public Hearing: Committee:	AS	AM	D
Assembly:	ASF	AMF	DF

ICCFILENAME:Devito-E1-1024.4

E132-09/10

707.3.10 (New), 1026 (IFC [B] 1026)

Proponent: Ron Clements, Chesterfield County Virginia Building Inspection Department, representing self

1. Revise as follows:

SECTION 1026 (IFC [B] 1026) EXTERIOR EXIT STAIRWAYS RAMPS AND RAMPS STAIRWAYS

1026.1 (IFC [B] 1026.1) General Exterior exit ramps and stairways. Exterior exit stairways ramps and ramps stairways serving as an exit component in the element of a required means of egress shall comply with this section.

Exception Exceptions: ~~Exterior exit ramps and stairways for outdoor stadiums complying with Section 1022.1, Exception 2.~~

1. Exits in buildings of Group A-5 where all portions of the means of egress are essentially open to the outside are not required be comply with this section.
2. Stairways in open parking structures that serve only the parking structure are not required to comply with this section.

1026.2 (IFC [B] 1026.2) Occupancy and height limitations Use in a means of egress. Exterior exit stairways shall not be used as an element of a required means of egress for occupancies in Group I-2. For occupancies in other than Group I-2, In other than Group I-2 occupancies, exterior exit stairways ramps and ramps stairways shall be permitted as an element of a required means of egress exit for in buildings not exceeding more than six stories above grade plane in height or having occupied floors more than 75 feet (22 860 mm) above the lowest level of fire department vehicle access.

1026.3 (IFC [B] 1026.3) Open side. Exterior exit stairways ramps and ramps stairways serving as an element of a required means of egress shall be open to a yard, court or public way on at least one side. An The open side shall have a minimum of 35 square feet (3.3 m²) of aggregate open area adjacent to each floor level and the level of each intermediate landing. The required open area shall be located not less than 42 inches (1067 mm) above the adjacent floor or landing level.

1026.4 (IFC [B] 1026.4) Side yards. ~~The open areas adjoining exterior exit ramps or stairways shall be either yards, courts or public ways; the remaining sides are permitted to be enclosed by the exterior walls of the building.~~

1026.5 1026.4 (IFC [B] 1026.5 1026.4) Fire separation distance Location. Exterior exit stairways and ramps and stairways shall be located in accordance with Section 1027.3. have a fire separation distance of not less than 10 feet. The outermost vertical plane of the exterior stair assembly shall be considered the building face for the fire separation distance measurement.

1026.6 1026.5 (IFC [B] 1026.6 1026.5) Exterior ramps and stairway protection. Exterior exit stairways and ramps and stairways shall be separated from the interior of the building with fire barriers constructed in accordance with Section 707 or horizontal assemblies constructed in accordance with Section 712, or both. Such separation shall have a fire-resistance rating of not less than 2 hours where connecting four stories or more and not less than 1 hour where connecting less than four stories as required in Section 1022.4. Openings in such fire barriers shall be limited to those necessary for egress from normally occupied spaces.

Where the sides of the exterior stairway or ramp are exposed to other parts of the building at an angle of less than 180 degrees (3.14 rad), the exterior walls of the building within 10 feet (3048 mm) horizontally of the exterior stairway or ramp exposed sides shall have a fire-resistance rating of not less than 1 hour or the exposed side of the exterior stairway must be a wall constructed as a fire barrier having a fire-resistance rating of not less than 1 hour. Openings within the 1 hour fire-resistive rated exposure protection shall be protected by opening protectives having a fire protection rating of not less than 3/4-hour. The fire rated construction shall extend vertically from the ground to a point 10 feet (3048 mm) above the topmost landing of the stairway or to the roof line, whichever is lower.

Exceptions:

1. In other than Group R-1 or R-2 occupancies, separation from the interior of the building is not required for occupancies, other than those in Group R-1 or R-2, in buildings that are no more than two stories above grade plane where a level of exit discharge serving such occupancies is the first story above grade plane.
2. Separation from the interior of the building is not required where the exterior ~~exit stairway ramp and ramp stairway~~ is served by an exterior ramp and/or balcony that connects two remote exterior stairways or other approved exits, with a perimeter that is not less than 50 percent open. To be considered open, the opening shall be a minimum of 50 percent of the height of the enclosing wall, with the top of the openings no less than 7 feet (2134 mm) above the top of the balcony.
3. Separation from the interior of the building is not required for an exterior ~~exit stairway ramp and ramp stairway~~ serving located in a building or structure that is permitted to have unenclosed interior stairways in accordance with Section 1022.1.
4. Separation from the interior of the building is not required for exterior ~~exit stairways ramps and ramps stairways~~ connected to open-ended corridors provided that Items 4.1 through 4.4 are met:
 - 4.1. The building, including corridors, ~~exit stairways ramps and or ramps stairs~~, shall be equipped throughout with an automatic sprinkler system in accordance with Section 903.3.1.1 or 903.3.1.2.
 - 4.2. The open-ended corridors comply with Section 1018.
 - 4.3. The open-ended corridors are connected on each end to an exterior exit ramp or stairway complying with Section 1026.
 - 4.4. At any location in an open-ended corridor where a change of direction exceeding 45 degrees (0.79 rad) occurs, a clear opening of not less than 35 square feet (3.3 m²) or an exterior ~~exit stairway ramp and ramp stairway~~ shall be provided. Where clear openings are provided, they shall be located so as to minimize the accumulation of smoke or toxic gases.

2. Add new text as follows:

707.3.10 Exterior Exit Stairways and ramps. The fire-resistance rating of the fire barrier separating building areas from an exterior exit stairway and ramp shall comply with Section 1026.5.

Reason: This is an attempt to clean up the exterior exit stair provisions. First the majority of exterior exit elements that are designed in accordance with this section are stairs, not ramps therefore Stairway has been placed before Ramp.

Section 1026.1 has been re-titled as General so the title is not a restatement of the overall section title and follows the common code format. The exception for open exterior stairways have been revised to allow exterior exit stairways that are attached to open buildings to not have to meet the provisions in this section since the danger of smoke accumulation in the stairway is not there.

Section 1026.2 changes are all editorial.

Section 1026.4 was deleted and the requirement for the stair to be open to a yard was added to Section 1026.3.

Section 1026.5 Location was renamed separation distance and the 10 fire separation distance based on Section 1027.2 was included in section 1026.5 and the reference to Section 1027.3 was removed. Exterior exit stairs are not part of the exit discharge therefore it is incorrect and confusing to reference the separation requirements on exit discharge requirements. Furthermore a cross reference was added for Section 705.2.

Section 1026.6 was modified to include the fire rated protection requirements for an exterior stair in the exterior stair section and remove the reference to interior exit stairs. These are not interior exit stairs and the protection requirements should be available in the exterior exit stair section specific to exterior exit stairs.

Section 707.3.10 was added in keeping with the organization of Section 707.3 listing as a cross reference all of the locations fire barriers are used.

Cost Impact: This proposal will not increase the cost of construction.

Public Hearing: Committee:	AS	AM	D
Assembly:	ASF	AMF	DF

ICCFILENAME:Clements-E5-1026

E133-09/10

1026.6 (IFC [B] 1026.6)

Proponent: Anne VonWeller, Murray City, representing the Utah Chapter of the International Code Council

Revise as follows:

1026.6 (IFC [B] 1026.6) Exterior ramps and stairway protection. Exterior exit ramps and stairways shall be separated from the interior of the building as required in Section 1022.1. Openings shall be limited to those necessary for egress from normally occupied spaces.

Exceptions:

1. Separation from the interior of the building is not required for occupancies, other than those in Group R-1 or R-2, in buildings that are no more than two stories above grade plane where a level of exit discharge serving such occupancies is the first story above grade plane.
2. Separation from the interior of the building is not required where the exterior ramp or stairway is served by an exterior ramp or balcony that connects two remote exterior stairways or other approved exits, with a perimeter that is not less than 50 percent open. To be considered open, the opening shall be a minimum of 50 percent of the height of the enclosing wall, with the top of the openings no less than 7 feet (2134 mm) above the top of the balcony.
3. Separation from the interior of the building is not required for an exterior ramp or stairway located in a building or structure that is permitted to have unenclosed interior stairways in accordance with Section 1022.1 or Exceptions 3 and 4 of Section 1016.1.
4. Separation from the interior of the building is not required for exterior ramps or stairways connected to open-ended corridors, provided that Items 4.1 through 4.4 are met:
 - 4.1. The building, including corridors and ramps and stairs, shall be equipped throughout with an automatic sprinkler system in accordance with Section 903.3.1.1 or 903.3.1.2.
 - 4.2. The open-ended corridors comply with Section 1018.
 - 4.3. The open-ended corridors are connected on each end to an exterior exit ramp or stairway complying with Section 1026.
 - 4.4. At any location in an open-ended corridor where a change of direction exceeding 45 degrees (0.79 rad) occurs, a clear opening of not less than 35 square feet (3.3 m²) or an exterior ramp or stairway shall be provided. Where clear openings are provided, they shall be located so as to minimize the accumulation of smoke or toxic gases.

Reason: In the 2009 Edition a distinction has been made between 'exit' stairways and ramps and 'exit access' stairways and ramps. In the past all of the exceptions for unenclosed stairways and ramps occurred in Section 1022.1. Now some of those exceptions are located in Section 1022.1 and some in Section 1016. This change is to lead user to the new location for the two exceptions relocated to Section 1016.1.

Cost Impact: The code change proposal will not increase the cost of construction.

Public Hearing: Committee:	AS	AM	D
Assembly:	ASF	AMF	DF

ICCFILENAME:Vonweller-E1-1023.6

E134–09/10

1026.6 (IFC [B] 1026.6)

Proponent: Rej Simenson, City of Aurora Building Codes Division, Aurora, Colorado

Revise as follows:

1026.6 (IFC [B] 1026.6) Exterior ramps and stairway protection. Exterior exit ramps and stairways shall be separated from the interior of the building as required in Section 1022.1. Openings shall be limited to those necessary for egress from normally occupied spaces.

Exceptions:

1. Separation from the interior of the building is not required for occupancies, other than those in Group R-1 or R-2, in buildings that are no more than two stories above grade plane where a level of exit discharge serving such occupancies is the first story above grade plane.
2. Separation from the interior of the building is not required where the exterior ramp or stairway is served by an exterior ramp or balcony that connects two remote exterior stairways or other approved exits, with a perimeter that is not less than 50 percent open. To be considered open, the opening shall be a minimum of 50 percent of the height of the enclosing wall, with the top of the openings no less than 7 feet (2134 mm) above the top of the balcony.
3. Separation from the interior of the building is not required for an exterior ramp or stairway located in a building or structure that is permitted to have unenclosed interior stairways in accordance with Section 1022.1.
4. Separation from the interior of the building is not required for exterior ramps or stairways connected to open-ended corridors, provided that the adjacent exterior wall and openings comply with Section 1022.6 and Items 4.1 through 4.4 are met:
 - 4.1. The building, including corridors and ramps and stairs, shall be equipped throughout with an automatic sprinkler system in accordance with Section 903.3.1.1 or 903.3.1.2.
 - 4.2. The open-ended corridors comply with Section 1018.
 - 4.3. The open-ended corridors are connected on each end to an exterior exit ramp or stairway complying with Section 1026.
 - 4.4. At any location in an open-ended corridor where a change of direction exceeding 45 degrees (0.79 rad) occurs, a clear opening of not less than 35 square feet (3.3 m²) or an exterior ramp or stairway shall be provided. Where clear openings are provided, they shall be located so as to minimize the accumulation of smoke or toxic gases.

Reason: This code change directs the code user back to Section 1022.6 for the building wall and opening rating requirements adjacent to the exterior exit stairway openings. The 2009 Section 1022.6 requirements protect openings on the exterior of the exit enclosure from fires on the interior of the building that may project through windows or other openings in the exterior building walls at an angle of less than 180 degrees. This code change clarifies the minimum protection for occupants and fire responders using the exit.

The original exception #4 eliminated the interior separation wall and door between the interior corridor and the exterior exit stairway. Separation from the **exterior** building wall at less than 180 degrees is NOT addressed in exception 4 and this has led to varied application of this section to the exterior walls of the building adjacent to the exterior exit stairway when this exception was the end of the code research.

The exterior exit stairway is defined as an exit and the protection of exit enclosures from smoke and fire is addressed in Section 1022.6. This code change makes that code connection for this critical life safety protection within the exception. The designer is directed to that critical reference, so that lesser protection standards are not assumed for openings adjacent to an exterior exit stairway than other vertical exit enclosures. This code change clarifies the minimum exterior wall protection for safe exiting during an emergency for occupants and provides safety to the fire fighters and emergency responders during emergency operations.

The graphics below show an interpretation of this section and the unprotected openings without reference to Section 1022.6 requirements.



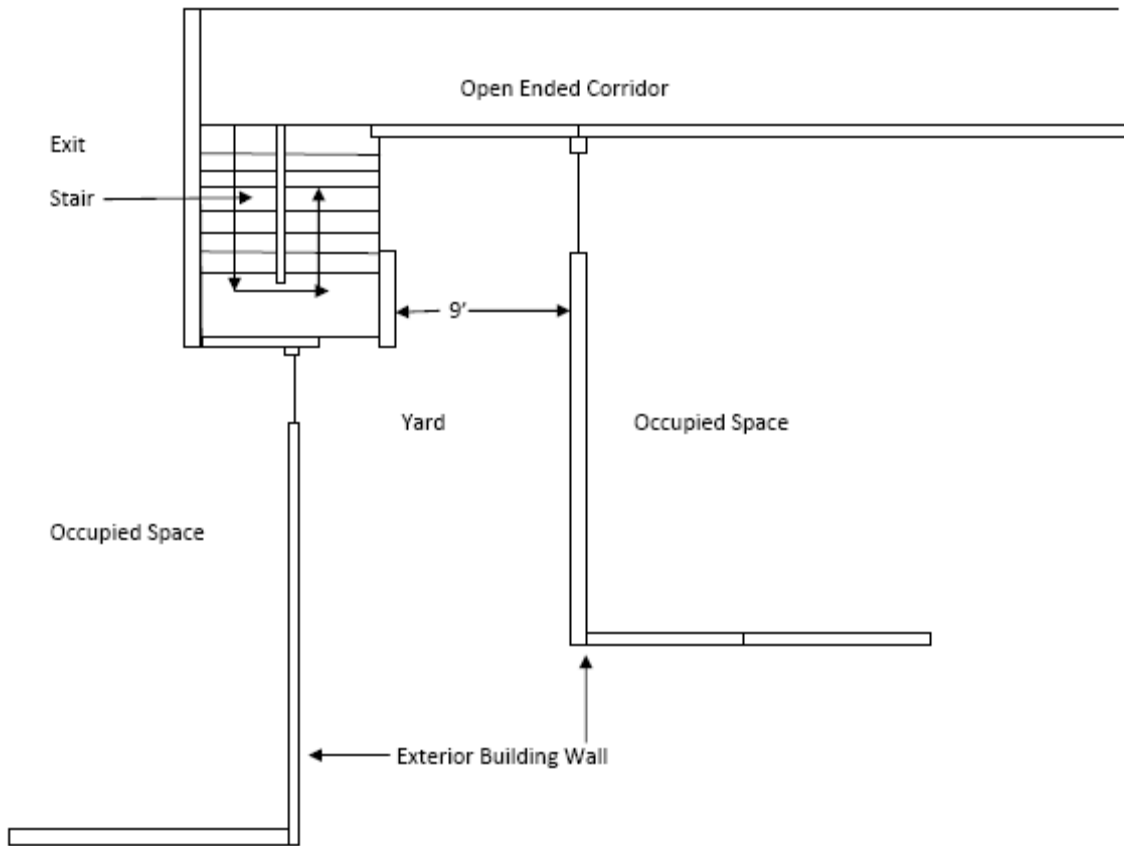

Cost Impact: The code change proposal will not increase the cost of construction.

Public Hearing: Committee: AS AM D
 Assembly: ASF AMF DF

ICCFILENAME:Simenson-E1-1026.6

E135-09/10

1027.1 (IFC [B] 1027.1)

Proponent: Homer Maiel, PE, CBO, City of San Jose, representing ICC Tri-Chapter (Peninsula, East Bay, Monterey Bay)

Revise as follows:

1027.1 (IFC [B] 1027.1) General. Exits shall discharge directly to the exterior of the building. The exit discharge shall be at grade or shall provide direct access to grade. The exit discharge shall not reenter a building. The combined use of Exceptions 1 and 2 below shall not exceed 50 percent of the number and capacity of the required exits.

Exceptions:

1. A maximum of 50 percent of the number and capacity of exit enclosures is permitted to egress through areas on the level of discharge provided all of the following are met.
 - 1.1 Such exit enclosures egress to a free and unobstructed path of travel to an exterior exit door and such exit is readily visible and identifiable from the point of termination of the exit enclosure.
 - 1.2 The entire area of the level of exit discharge is separated from areas below by construction conforming to the fire-resistance rating for the exit enclosure.
 - 1.3 The egress path from the exit enclosure on the level of exit discharge is protected throughout by an approved automatic sprinkler system. All portions of the level of exit discharge with access to the egress path shall either be protected throughout with an automatic sprinkler system installed in accordance with Section 903.3.1.1 or 903.3.1.2, or separated from the egress path in accordance with the requirements for the enclosure of exits ~~exit enclosure~~.
2. A maximum of 50 percent of the number and capacity of the exit enclosures is permitted to egress through

a vestibule provided all of the following are met:

- ~~2.4~~2.1 The area is used only for means of egress and exits directly to the outside.
 - 2.2 The vestibule depth from the exterior of the building is not greater than 10 feet (3048 mm) and the vestibule length is not greater than 30 feet (9144 mm).
 - 2.3 The area is separated from the remainder of the level of exit discharge by a fire barrier having a one hour fire-resistance rating, construction providing protection at least the equivalent of approved wire glass in steel frames. Doors and windows in the separation walls shall be rated $\frac{3}{4}$ hour and shall not exceed the size limits specified in Section 707.6. Duct penetrations shall comply with Section 713.1.1, and other penetrations shall comply with Section 713.3.
 - ~~2.4~~2.4 The entire area of the vestibule is separated from areas below by construction conforming to the fire-resistance rating for the exit enclosure.
3. Stairways in open parking garages complying with Section 1022.1, Exception 4, are permitted to egress through the open parking garage at their levels of exit discharge.
 4. Horizontal exits complying with Section 1025 shall not be required to discharge directly to the exterior of the building.

Reason: Exception item 1.3 is editorially revised to replace the wording "requirements for the enclosure of exits" with "requirements for the "exit enclosure". The existing wording is vague because it does not specify the type of exit (exit enclosure) that it intends to require, while the replacement wording matches that used in current items 1.2 and 2.1

In Exception 2, items 2.1 and 2.4 are relocated but their wording is unchanged, and exception items 2.2 and 2.3 are revised with new wording. Exceptions 3 and 4 are unchanged.

Existing item 2.4 is unchanged, but is relocated to the beginning (becomes item 2.1) because it states a primary egress criterion, and because it corresponds to the type of information specified in item 1.1 of Exception 1.

Existing item 2.1 is unchanged, but is relocated to the end (becomes item 2.4).

Existing item 2.2 has the word "vestibule" added before the depth and length dimensions, to clarify that these dimension apply to the vestibule's maximum size.

Existing item 2.3 has its first sentence revised to specify exactly what type of rated wall and what minimum fire resistance must be provided to separate the vestibule from other areas on the level of discharge. Item 2.3 currently only vaguely describes what is intended by making the statement "*construction providing protection at least the equivalent of approved wire glass in steel frames*". Not only does that statement not provide specific guidance regarding wall type or minimum rating, it is also silent regarding the rating of the wire glass or its maximum area.

To remedy this lack of specificity, a new second sentence is added to specify a minimum $\frac{3}{4}$ hour rating for any door and window openings in the separation wall. That rating is consistent with Table 715.4 for doors in "other fire barriers" having one hour rating, and with Table 715.5 for windows in one hour rated fire barriers. The $\frac{3}{4}$ hour rating allows wire glass to be used, but places limits on the size of those windows, as specified for $\frac{3}{4}$ hour wire glass panels in Table 715.4. The second sentence also limits total opening area consistent with the limits set forth in Section 707.6 for all fire barrier walls. A new third sentence also specifies that duct penetrations and other penetrations in the separation wall must comply with Sections 713.1.1 and 713.3.

Code users need more specificity regarding the construction of the fire resistive walls surrounding the vestibule permitted in exception 2. Adequate protection of this interior space on the level of discharge is certainly warranted to ensure the safety of occupants during egress and to provide protection of fire personnel entering through the vestibule to use the exit enclosure for rescue or fire suppression. This change intends to bring the necessary specificity into this code provision by providing one hour rated fire barrier walls and $\frac{3}{4}$ hour rated door or window openings of a size appropriate for the nature of the egress component being protected.

Cost Impact: The code change proposal will not increase the cost of construction.

Public Hearing:	Committee:	AS	AM	D
	Assembly:	ASF	AMF	DF

ICCFILENAME:Maiei-E6-1027.1

E136-09/10

1027.1 (IFC [B] 1027.1)

Proponent: Sarah A. Rice, CBO, representing self

Revise as follows:

1027.1 (IFC [B] 1027.1) General. Exits shall discharge directly to the exterior of the building. The exit discharge shall be at grade or shall provide direct access to grade. The exit discharge shall not reenter a building. The combined use of Exceptions 1 and 2 below shall not exceed 50 percent of the number and capacity of the required exits.

Exceptions:

1. A maximum of 50 percent of the number and capacity of the exit enclosures is permitted to egress through areas on the level of discharge provided all of the following are met:
 - 1.1. Such exit enclosures egress to a free and unobstructed path of travel to an exterior exit door and such exit is readily visible and identifiable from the point of termination of the exit enclosure.

- 1.2. The entire area of the level of exit discharge is separated from areas below by construction conforming to the fire-resistance rating for the exit enclosure.
- 1.3. The egress path from the exit enclosure on the level of exit discharge is protected throughout by an approved automatic sprinkler system. All portions of the level of exit discharge with access to the egress path shall either be protected throughout with an automatic sprinkler system installed in accordance with Section 903.3.1.1 or 903.3.1.2, or separated from the egress path in accordance with the requirements for the enclosure of exits.
2. A maximum of 50 percent of the number and capacity of the exit enclosures is permitted to egress through a vestibule provided all of the following are met:
 - 2.1. The entire area of the vestibule is separated from areas below by construction conforming to the fire-resistance rating for the exit enclosure.
 - 2.2. The depth from the exterior of the building is not greater than 10 feet (3048 mm) and the length is not greater than 30 feet (9144 mm).
 - 2.3. The area is separated from the remainder of the level of exit discharge by construction providing protection at least the equivalent of approved wired glass in steel frames.
 - 2.4. The area is used only for means of egress and exits directly to the outside.
3. Stairways in open parking garages complying with Section 1022.1, Exception 4, are permitted to egress through the open parking garage at their levels of exit discharge.
4. Horizontal exits complying with Section 1025 shall not be required to discharge directly to the exterior of the building.
5. The exit discharge for an exit enclosure which terminate in a court without direct access to a public way is permitted to reenter the building provided one of the following are met:
 - 5.1. An exit passageway which has the same fire-resistance rating as the exit enclosure served, is provided through the building from the court to an exterior wall of the building fronting on a public way; or
 - 5.2. A covered walkway which is open to the atmosphere at opposite ends is provided through the building to an exterior wall fronting on a public way and which has walls and ceiling of not less than 1 hour fire-resistance-rated-construction and opening protected with opening protectives have not less than a ¾ hour rating.

Reason: Prior to 1997 at least one of the legacy codes allowed exit enclosures to terminate into an open central court surround on all sides by a building. To provide exit discharge from such court, the code permitted an exit passageway. The IBC is silent on this type of design, and a strict reading of Section 1027.1 would prohibit it. The exception proposes two options. The first is the exit passageway. The second is an open 'breezeway' or 'tunnel' which goes from the court to the public way. It has been interpreted that the code allows the approach in 5.2 because it doesn't 're-enter' the building, but simply goes 'under' the building. This proposal codifies that interpretation. Essentially the 5.2 option is a passageway without enclosures at either end. To be consistent with other exit passageways, the passageway allowed here should have the same rating as the vertical exit enclosure served. Only one hour is proposed for the open breezeways as this is consistent with the egress court provisions in Section 1027 and because this is an atmospherically open tunnel, 1 hour should be sufficient to protect the users.

Cost Impact: The code change proposal will not increase the cost of construction.

Public Hearing: Committee:	AS	AM	D
Assembly:	ASF	AMF	DF

ICCFILENAME:Rice-E2-1027.1

E137-09/10

705.2, 1027.3 (IFC [B] 1027.3)

Proponent: Ron Clements, Chesterfield County Virginia Building Inspection Department, representing self

Revise as follows:

1027.3 (IFC [B] 1027.3) Exit discharge separation distance location. Exterior balconies, stairways and ramps within the exit discharge component of the means of egress shall be located separated in accordance with Section 705.2 at least 10 feet (3048 mm) from adjacent lot lines and from other buildings on the same lot unless the adjacent building exterior walls and openings are protected in accordance with Section 705 based on fire separation distance.

705.2 Projections. Cornices, eave overhangs, exterior balconies, exterior stairways, and exterior ramps, and similar projections extending beyond the exterior wall shall conform the requirements of this section and Section 1406. Exterior egress balconies and exterior exit stairways shall also comply with Section 1019 and 1026, respectively. Projections shall not extend beyond the distance determined by the following three methods, whichever results in the lesser projections:

1. A point one-third the distance from the exterior face of the wall to the lot line where protected openings or a combination of protected and unprotected openings are required in the exterior wall.
2. A point one-half the distance from the exterior face of the wall to the lot line where all openings in the exterior wall are permitted to be unprotected or the building is equipped throughout with an automatic sprinkler system installed under the provisions of Section 705.8.2.
3. More than 12 inches (305 mm) into areas where openings are prohibited.

Buildings on the same lot and considered as portions of one building in accordance with Section 705.3 are not required to comply with this section.

Reason: The intent of this change is to refer back to Section 705.2 for separation distance requirements related to exterior exit discharge balconies, ramps and stairways. Additionally Section 705.2 Projections in chapter 7 provides the required separation guidelines for building elements that project out past the exterior wall of the building and includes exterior balconies and exterior exit stairways and ramps. Another issue with the text proposed for deletion is that the 10 feet is measured to the other building on the same lot unless the exterior walls are protected. That leaves the question if the exterior walls are protected for) clearances is no clearance required between the adjacent building's exterior wall and the balcony or stair if 705.2 is limiting the projection per the 3 items in 705.2?

Section 705.2 is included to add Stairways and Ramps to the section.

Cost Impact: The code change proposal will not increase the cost of construction.

Public Hearing: Committee:	AS	AM	D
Assembly:	ASF	AMF	DF

ICCFILENAME:Clements-E4-1027.3

E138-09/10

1027.3 (IFC [B] 1027.3)

Proponent: Lawrence Brown, CBO, National Association of Home Builders (NAHB); Eirene Oliphant, MCP, Building Official, representing City of Leawood, KS

Revise as follows:

1027.3 (IFC [B] 1027.3) Exit discharge location. Exterior balconies, stairways and ramps shall be located at least 10 feet (3048 mm) from adjacent lot lines and from other buildings on the same lot unless the adjacent building exterior walls and openings are protected in accordance with Section 705 based on fire separation distance.

Exception: Where serving Group R-3 occupancies, exterior balconies, stairways and ramps shall be permitted to be located 5 feet (1524 mm) minimum from adjacent lot lines and from other buildings on the same lot.

Reason: The added exception will help to coordinate this section with the provisions found in Table 705.8. Footnote "f" of Table 705.8 allows an unlimited amount of unprotected openings with a fire separation distance of 5 feet or greater. It would seem reasonable to allow the exterior stairways, ramps and balconies for a Group R-3 to be located in the 5 to 10 foot range if it is permissible to have an unlimited amount of unprotected openings.

While the 10 foot provision of this section does coordinate with the exterior wall rating required in Table 602 for most Group R-3 construction, permitting an unlimited amount of unprotected openings in that wall effectively eliminates the required protection beyond the 5 foot distance. Changing this section will help to coordinate with many local zoning laws that impose a 5 foot side yard requirement in residential areas. In addition Table R302.1 of the IRC permits walls to be non-rated if over 5 feet.

If the committee and members would consider another possible exception, it may be reasonable to add a second exception that would coordinate with footnote "d" of Table 705.8. This second exception would allow exterior stairs, ramps and balconies to have a minimum of 3 feet of separation provided that the wall had no more than 25 percent of unprotected or protected openings. Possible wording would be:

Exceptions:

2. In Group R-3 occupancies where the exterior wall of the exterior stairway, ramp and balcony comply with footnote "d" of Table 705.8, a separation of 3 feet (915 mm) minimum shall be provided from adjacent lot lines and from other buildings on the same lot.

This second exception would not only coordinate with the provisions of Table 705.8 but would seem to correct an inconsistency that occurs within the code. As currently written, the code would allow an "interior" stairway to be located within the 3 to 5 foot range and allow 25 percent of the wall to be an unprotected opening. However, if that opening or an opening on an adjacent side exceeded 35 square feet (Section 1026.3) and the stair then was considered as an "exterior" stair it would need to be located "at least 10 feet (3048 mm) from adjacent lot lines." If the level of protection provided for the wall facing the property line is consistent then the code should not impose a 10 foot requirement on "exterior" stairs while allowing "interior" stairs to be 3 feet from the line.

Cost Impact: The code change proposal will not increase the cost of construction.

Public Hearing: Committee:	AS	AM	D
Assembly:	ASF	AMF	DF

ICCFILENAME:Brown-E1-1027.3

E139–09/10

1019.4 (New), 1026.5, 1027.3 (IFC [B] 1019.4 (New), 1026.5, 1027.3)

Proponent: Gary Pringey representing Colorado Code Consulting, LLC, Colorado Chapter ICC

1. Delete without substitution:

~~1027.3 (IFC [B] 1027.3) Exit discharge location. Exterior balconies, stairways and ramps shall be located at least 10 feet (3048 mm) from adjacent lot lines and from other buildings on the same lot unless the adjacent building exterior walls and openings are protected in accordance with Section 705 based on fire separation distance.~~

(Renumber following subsections)

2. Add new text as follows:

1019.4 (IFC [B] 1019.4) Location. Exterior egress balconies shall have a minimum fire separation distance of 10 feet (3048 mm) measured from the exterior edge of the egress balcony to adjacent lot lines and from other buildings on the same lot unless the adjacent building exterior walls and openings are protected in accordance with Section 705 based on fire separation distance.

3. Revise as follows:

1026.5 (IFC [B] 1026.5) Location. Exterior exit ramps and stairways shall be located in accordance with Section 4027.3 have a minimum fire separation distance of 10 feet (3048 mm) measured from the exterior edge of the ramp or stairway, including landings to adjacent lot lines and from other buildings on the same lot unless the adjacent building exterior walls and openings are protected in accordance with Section 705 based on fire separation distance.

Reason: The purpose of this proposal is to centralize and clarify design requirements for the exit access portion and exit portion of the means of egress system. Obviously, Section 1027 is titled "EXIT DISCHARGE." Requirements in Section 1027.3 apply only to exterior egress balconies, which are components in the Exit Access, and exterior exit ramps and stairways, which are components in the Exit. These design provisions are mislocated.

Requirements for exterior egress balconies are stated in Section 1019. This proposal relocates the intent of the requirement for the location of exterior egress balconies to Section 1019.4, the applicable subsection for that exit access component. This proposal relocates the intent of the requirement for location of exterior exit ramps and stairways to Section 1026.5. Section 1027.3 is deleted as an inappropriate location to specify design requirements for components of the Exit Access and Exit elements.

Approval of this proposal will clarify current code provisions and assist in the proper determination of exit access and exit design requirements.

Cost Impact: The code change proposal will not increase the cost of construction.

Public Hearing: Committee:	AS	AM	D
Assembly:	ASF	AMF	DF

ICCFILENAME: PRINGEY-E1-1014.5.3 NEW

E140–09/10

303.1, 1010.2, 1014.3, 1017, 1028, 1104.3, 1104.3.2, 1108.2, (IFC [B] 202, 1010.2, 1014.3, 1017, 1028)

Proponent: Ed Roether, Populous (Formerly HOK Sport Venue Event), representing self

Revise as follows:

303.1 (IFC [B] 202) Assembly Group A. Assembly Group A occupancy includes, among others, the use of a building or structure, or a portion thereof, for the gathering of persons for purposes such as civic, social or religious functions; recreation, food or drink consumption or awaiting transportation.

Exceptions:

1. A building or tenant space used for assembly purposes with an occupant load of less than 50 persons shall be classified as a Group B occupancy.
2. A room or space used for assembly purposes with an occupant load of less than 50 persons and accessory to another occupancy shall be classified as a Group B occupancy or as part of that occupancy.

3. A room or space used for assembly purposes that is less than 750 square feet (70m²) in area and accessory to another occupancy shall be classified as a Group B occupancy or as part of that occupancy.
4. ~~Assembly areas~~ A room or space used for assembly purposes that are ~~accessory to~~ associated with a Group E occupancies are not considered separate occupancies ~~except when applying the assembly occupancy requirements of Chapter 11.~~
5. Accessory religious educational rooms and religious auditoriums with occupant loads of less than 100 are not considered separate occupancies.

1010.2 (IFC [B] 1010.2) Slope. Ramps used as part of a means of egress shall have a running slope not steeper than one unit vertical in 12 units horizontal (8-percent slope). The slope of other pedestrian ramps shall not be steeper than one unit vertical in eight units horizontal (12.5-percent slope).

Exception: Aisle ramp slope in a room or space used for assembly purposes ~~occupancies of Group A or assembly occupancies accessory to Group E occupancies~~ shall comply with Section 1028.11.

1014.3 (IFC [B] 1014.3) Common path of egress travel. In occupancies other than Groups H-1, H-2 and H-3, the common path of egress travel shall not exceed 75 feet (22 860 mm). In Group H-1, H-2 and H-3 occupancies, the common path of egress travel shall not exceed 25 feet (7620 mm). For common path of egress travel in a room or space used for assembly purposes ~~Group A occupancies and assembly occupancies accessory to Group E occupancies~~ having fixed seating, see Section 1028.8.

Exceptions:

1. The length of a common path of egress travel in Group B, F and S occupancies shall not be more than 100 feet (30 480 mm), provided that the building is equipped throughout with an automatic sprinkler system installed in accordance with Section 903.3.1.1.
2. Where a tenant space in Group B, S and U occupancies has an occupant load of not more than 30, the length of a common path of egress travel shall not be more than 100 feet (30 480 mm).
3. The length of a common path of egress travel in a Group I-3 occupancy shall not be more than 100 feet (30 480 mm).
4. The length of a common path of egress travel in a Group R-2 occupancy shall not be more than 125 feet (38 100 mm), provided that the building is protected throughout with an approved automatic sprinkler system in accordance with Section 903.3.1.1 or 903.3.1.2.

**SECTION 1017 (IFC [B] 1017)
AISLES and AISLE ACCESSWAYS**

1017.1 (IFC [B] 1017.1) General. Aisles and aisle accessways serving as a portion of the exit access in the means of egress system shall comply with the requirements of this section. Aisles or aisle accessways shall be provided from all occupied portions of the exit access which contain seats, tables, furnishings, displays and similar fixtures or equipment. Aisles serving a room or space used for assembly purposes ~~areas~~ shall comply with Section 1028. ~~Aisles serving reviewing stands, grandstands and bleachers shall also comply with Section 1028.~~ The required width of aisles shall be unobstructed.

Exception: Doors complying with Section 1005.2.

~~**1017.4 (IFC [B] 1017.4) Seating at tables.** (Relocate to Section 1028)~~

~~**1017.4.1 (IFC [B] 1017.4.1) Aisle accessway for tables and seating.** (Relocate to Section 1028)~~

~~**1017.4.2 (IFC [B] 1017.4.2) Table and seating accessway width.** (Relocate to Section 1028)~~

~~**1017.4.3 (IFC [B] 1017.4.3) Table and seating aisle accessway length.** (Relocate to Section 1028)~~

**SECTION 1028
ASSEMBLY**

1028.1 (IFC [B] 1028.1) General. A room or space used for assembly purposes ~~Occupancies in Group A and assembly occupancies accessory to Group E~~ which contain seats, tables, displays, equipment or other material shall comply with this section.

1028.2 (IFC [B] 1028.2) Assembly main exit. ~~Group A~~ A building, room or space used for assembly purposes ~~occupancies and assembly occupancies accessory to Group E occupancies~~ that have has an occupant load of greater than 300 ~~shall be and~~ provided with a main exit. ~~The ,~~ the main exit shall be of sufficient width to accommodate not less than one-half of the occupant load, but such width shall not be less than the total required width of all means of egress leading to the exit. Where the building is classified as a Group A occupancy, the main exit shall front on at least one street or an unoccupied space of not less than 10 feet (3048 mm) in width that adjoins a street or public way. In a building, room or space used for assembly purposes where there is no well-defined main exit or where multiple main exits are provided, exits shall be permitted to be distributed around the perimeter of the building provided that the total width of egress is not less than 100 percent of the required width.

Exception: ~~In assembly occupancies where there is no well-defined main exit or where multiple main exits are provided, exits shall be permitted to be distributed around the perimeter of the building provided that the total width of egress is not less than 100 percent of the required width.~~

1028.3 (IFC [B] 1028.3) Assembly other exits. In addition to having access to a main exit, each level in ~~Group A~~ a building used for assembly purposes ~~occupancies or assembly occupancies accessory to Group E occupancies~~ having an occupant load greater than 300 and provided with a main exit, shall be provided with additional means of egress that shall provide an egress capacity for at least one-half of the total occupant load served by that level and comply with Section 1015.2. In a building used for assembly purposes where there is no well-defined main exit or where multiple main exits are provided, exits for each level shall be permitted to be distributed around the perimeter of the building, provided that the total width of egress is not less than 100 percent of the required width.

Exception: ~~In assembly occupancies where there is no well-defined main exit or where multiple main exits are provided, exits shall be permitted to be distributed around the perimeter of the building, provided that the total width of egress is not less than 100 percent of the required width.~~

1028.5 (IFC [B] 1028.5) Interior balcony and gallery means of egress. For balconies, galleries or press boxes having a seating capacity of 50 or more located in a building, room or space used for assembly purposes ~~Group A occupancies~~, at least two means of egress shall be provided, with one from each side of every balcony, gallery or press box and at least one leading directly to an exit.

1028.6.2 (IFC [B] 1028.6.2) Smoke-protected seating. The clear width of the means of egress for smoke-protected assembly seating shall not be less than the occupant load served by the egress element multiplied by the appropriate factor in Table 1028.6.2. The total number of seats specified shall be those within the space exposed to the same smoke-protected environment. Interpolation is permitted between the specific values shown. A life safety evaluation, complying with NFPA 101, shall be done for a facility utilizing the reduced width requirements of Table 1028.6.2 for smoke-protected assembly seating.

Exception: For an outdoor smoke-protected assembly seating with an occupant load not greater than 18,000, the clear width shall be determined using the factors in Section 1028.6.3.

**TABLE 1028.6.2(IFC [B] 1028.6.2)
WIDTH OF AISLES FOR SMOKE-PROTECTED ASSEMBLY**

TOTAL NUMBER OF SEATS IN THE SMOKEPROTECTED ASSEMBLY OCCUPANCY SEATING	INCHES OF CLEAR WIDTH PER SEAT SERVED			
	Stairs and aisle steps with handrails within 30 inches	Stairs and aisle steps without handrails within 30 inches	Passageways, doorways and ramps not steeper than 1 in 10 in slope	Ramps steeper than 1 in 10 in slope

(Portions of table not shown remain unchanged)

1028.6.3 (IFC [B] 1028.6.3) Width of means of egress for outdoor smoke-protected assembly seating. The clear width in inches (mm) of aisles and other means of egress shall be not less than the total occupant load served by the egress element multiplied by 0.08 (2.0 mm) where egress is by aisles and stairs and multiplied by 0.06 (1.52 mm) where egress is by ramps, corridors, tunnels or vomitories.

Exception: The clear width in inches (mm) of aisles and other means of egress shall be permitted to comply with Section 1028.6.2 for the number of seats in the outdoor smoke-protected assembly seating where Section 1028.6.2 permits less width.

1028.9 (IFC [B] 1028.9) Assembly aisles are required. Every occupied portion of any a building, room or space used for assembly purposes occupancy in Group A or assembly occupancies accessory to Group E that contains seats, tables, displays, similar fixtures or equipment shall be provided with aisles leading to exits or exit access doorways in accordance with this section. Aisle accessways for tables and seating shall comply with Section 1017.4.

1028.10 (IFC [B] 1028.10) Aisle accessways. Aisle accessways for seating at tables shall comply with Section 1028.10.1. Aisle accessways for seating in rows shall comply with Section 1028.10.2.

1017.4 1028.10.1 (IFC [B] 1017.4 1028.10.1) Seating at tables. Where seating is located at a table or counter and is adjacent to an aisle or aisle accessway, the measurement of required clear width of the aisle or aisle accessway shall be made to a line 19 inches (483 mm) away from and parallel to the edge of the table or counter. The 19-inch (483 mm) distance shall be measured perpendicular to the side of the table or counter. In the case of other side boundaries for aisle or aisle accessways, the clear width shall be measured to walls, edges of seating and tread edges, except that handrail projections are permitted.

Exception: Where tables or counters are served by fixed seats, the width of the aisle accessway shall be measured from the back of the seat.

1017.4.4 1028.10.1.1 (IFC [B] 1017.4.4 1028.10.1.1) Aisle accessway width for seating at tables and seating. Aisle accessways serving arrangements of seating at tables or counters shall have sufficient clear width to conform to the capacity requirements of Section 1005.1 but shall not have less than the appropriate minimum clear width specified in Section 1017.4.2 a minimum of 12 inches (305 mm) of width plus 1/2 inch (12.7 mm) of width for each additional 1 foot (305 mm), or fraction thereof, beyond 12 feet (3658 mm) of aisle accessway length measured from the center of the seat farthest from an aisle.

1017.4.2 (IFC [B] 1017.4.2) Table and seating accessway width. Aisle accessways shall provide a minimum of 12 inches (305 mm) of width plus 1/2 inch (12.7 mm) of width for each additional 1 foot (305 mm), or fraction thereof, beyond 12 feet (3658 mm) of aisle accessway length measured from the center of the seat farthest from an aisle.

Exception: Portions of an aisle accessway having a length not exceeding 6 feet (1829 mm) and used by a total of not more than four persons.

1017.4.3 1028.10.1.2 (IFC [B] 1017.4.3 1028.10.1.2) Seating at table and seating aisle accessway length. The length of travel along the aisle accessway shall not exceed 30 feet (9144 mm) from any seat to the point where a person has a choice of two or more paths of egress travel to separate exits.

1028.10 1028.10.2 (IFC [B] 1028.10 1028.10.2) Clear width of aisle accessways serving seating in rows. Where seating rows have 14 or fewer seats, the minimum clear aisle accessway width shall not be less than 12 inches (305 mm) measured as the clear horizontal distance from the back of the row ahead and the nearest projection of the row behind. Where chairs have automatic or self-rising seats, the measurement shall be made with seats in the raised position. Where any chair in the row does not have an automatic or self-rising seat, the measurements shall be made with the seat in the down position. For seats with folding tablet arms, row spacing shall be determined with the tablet arm in the used position.

Exception: For seats with folding tablet arms, row spacing is permitted to be determined with the tablet arm in the stored position where the tablet arm when raised manually to vertical position in one motion automatically returns to the stored position by force of gravity.

1028.10.1 1028.10.2.1 (IFC [B] 1028.10.1 1028.10.2.1) Dual access. For rows of seating served by aisles or doorways at both ends, there shall not be more than 100 seats per row. The minimum clear width of 12 inches (305 mm) between rows shall be increased by 0.3 inch (7.6 mm) for every additional seat beyond 14 seats, but the minimum clear width is not required to exceed 22 inches (559 mm).

Exception: For smoke-protected assembly seating, the row length limits for a 12-inch-wide (305 mm) aisle accessway, beyond which the aisle accessway minimum clear width shall be increased, are in Table 1028.10.1.

**TABLE ~~1028.10.4~~ 1028.10.2.1(IFC [B] ~~1028.10.4~~ 1028.10.2.1)
SMOKE-PROTECTED
ASSEMBLY AISLE ACCESSWAYS**

TOTAL NUMBER OF SEATS IN THE SMOKEPROTECTED ASSEMBLY OCCUPANCY <u>SEATING</u>	MAXIMUM NUMBER OF SEATS PER ROW PERMITTED TO HAVE A MINIMUM 12-INCH CLEAR WIDTH AISLE ACCESSWAY	
	Aisle or doorway at both ends of row	Aisle or doorway at one end of row only

(Portions of table not shown remain unchanged)

~~1028.10.2~~ 1028.10.2.2 (IFC [B] ~~1028.10.2~~ 1028.10.2.2) Single access. For rows of seating served by an aisle or doorway at only one end of the row, the minimum clear width of 12 inches (305 mm) between rows shall be increased by 0.6 inch (15.2 mm) for every additional seat beyond seven seats, but the minimum clear width is not required to exceed 22 inches (559 mm).

Exception: For smoke-protected assembly seating, the row length limits for a 12-inch-wide (305 mm) aisle accessway, beyond which the aisle accessway minimum clear width shall be increased, are in Table ~~1028.10.4~~ 1028.10.2.1.

1028.12 (IFC [B] 1028.12) Seat stability. In ~~places of a building, room or space used for assembly purposes~~, the seats shall be securely fastened to the floor.

Exceptions:

1. In ~~places of a building, room or space used for assembly purposes~~ or portions thereof without ramped or tiered floors for seating and with 200 or fewer seats, the seats shall not be required to be fastened to the floor.
2. In ~~places of a building, room or space used for assembly purposes~~ or portions thereof with seating at tables and without ramped or tiered floors for seating, the seats shall not be required to be fastened to the floor.
3. In ~~places of a building, room or space used for assembly purposes~~ or portions thereof without ramped or tiered floors for seating and with greater than 200 seats, the seats shall be fastened together in groups of not less than three or the seats shall be securely fastened to the floor.
4. In ~~places of a building, room or space used for assembly purposes~~ where flexibility of the seating arrangement is an integral part of the design and function of the space and seating is on tiered levels, a maximum of 200 seats shall not be required to be fastened to the floor. Plans showing seating, tiers and aisles shall be submitted for approval.
5. Groups of seats within a ~~places of a building, room or space used for assembly purposes~~ separated from other seating by railings, guards, partial height walls or similar barriers with level floors and having no more than 14 seats per group shall not be required to be fastened to the floor.
6. Seats intended for musicians or other performers and separated by railings, guards, partial height walls or similar barriers shall not be required to be fastened to the floor.

1028.14 (IFC [B] 1028.14) Assembly guards. Assembly Guards adjacent to seating in a building, room or space used for assembly purposes shall comply with Sections 1028.14.1 through 1028.14.3.

~~1028.15 (IFC [B] 1028.15) Bench seating.~~ Where bench seating is used, the number of persons shall be based on one person for each 18 inches (457 mm) of length of the bench.

1104.3 Connected spaces. When a building or portion of a building is required to be accessible, an accessible route shall be provided to each portion of the building, to accessible building entrances connecting accessible pedestrian walkways and the public way.

Exceptions:

1. In a building, room or space used for assembly purposes ~~areas~~ with fixed seating, an accessible route shall not be required to serve levels where wheelchair spaces are not provided.
2. In Group I-2 facilities, doors to sleeping units shall be exempted from the requirements for maneuvering clearance at the room side provided the door is a minimum of 44 inches (1118 mm) in width.

1104.3.2 Press boxes. Press boxes in a building, room or space used for assembly purposes areas shall be on an accessible route.

Exceptions:

1. An accessible route shall not be required to press boxes in bleachers that have points of entry at only one level, provided that the aggregate area of all press boxes is 500 square feet (46 m²) maximum.
2. An accessible route shall not be required to free-standing press boxes that are elevated above grade 12 feet (3660 mm) minimum provided that the aggregate area of all press boxes is 500 square feet (46 m²) maximum.

1108.2 Assembly area seating. A building, room or space used for assembly purposes areas with fixed seating shall comply with Sections 1108.2.1 through ~~1108.2.8~~ 1108.2.5. Lawn seating areas shall comply with Section 1108.2.6. Assistive listening systems shall comply with Section 1108.2.7. Performance areas viewed from assembly seating areas shall comply with Section 1108.2.8. Dining areas shall comply with Section 1108.2.9. ~~In addition, lawn seating shall comply with Section 1108.2.6.~~

1108.2.1 Services. *(No change to text)*

1108.2.2 Wheelchair spaces. *(No change to text)*

1108.2.2.1 General seating. *(No change to text)*

1108.2.2.2 Luxury boxes, club boxes and suites. *(No change to text)*

1108.2.2.3 Other boxes. *(No change to text)*

**TABLE 1108.2.2.1
ACCESSIBLE WHEELCHAIR SPACES**

CAPACITY OF SEATING IN ASSEMBLY AREAS	MINIMUM REQUIRED NUMBER OF WHEELCHAIR SPACES
---------------------------------------	--

(Portions of table not shown remain unchanged)

1108.2.2.4 Team or player seating. *(No change to text)*

1108.2.3 Companion seats. *(No change to text)*

1108.2.4 Dispersion of wheelchair spaces in multilevel assembly seating areas. In multilevel assembly seating areas, wheelchair spaces shall be provided on the main floor level and on one of each two additional floor or mezzanine levels. Wheelchair spaces shall be provided in each luxury box, club box and suite within assembly facilities.

Exceptions:

1. In multilevel assembly seating areas ~~spaces~~ utilized for worship services where the second floor or mezzanine level contains 25 percent or less of the total seating capacity, wheelchair spaces shall be permitted to all be located on the main level.
2. In multilevel assembly seating areas where the second floor or mezzanine level provides 25 percent or less of the total seating capacity and 300 or fewer seats, all wheelchair spaces shall be permitted to be located on the main level.
3. Wheelchair spaces in team or player seating serving areas of sport activity are not required to be dispersed.

1108.2.5 Designated aisle seats. *(No change to text)*

1108.2.6 Lawn seating. *(No change to text)*

1108.2.7 Assistive listening systems. Each building, room or space used for assembly purposes area where audible communications are integral to the use of the space shall have an assistive listening system.

Exception: Other than in courtrooms, an assistive listening system is not required where there is no audio amplification system.

1108.2.7.1 Receivers. Receivers shall be provided for assistive listening systems in accordance with Table 1108.2.7.1.

Exceptions:

1. Where a building contains more than one room or space used for assembly purposes area, the total number of required receivers shall be permitted to be calculated according to the total number of seats ~~in the assembly areas~~ in the building, provided that all receivers are usable with all systems and if the rooms or spaces used for assembly purposes areas required to provide assistive listening are under one management.
2. Where all seats in ~~an a building, room or space used for assembly purposes area~~ are served by an induction loop assistive listening system, the minimum number of receivers required by Table 1108.2.7.1 to be hearing-aid compatible shall not be required.

1108.2.8 Performance areas. *(No change to text)*

1108.2.9 Dining areas. *(No change to text)*

1108.2.9.1 Dining surfaces. *(No change to text)*

Reason: Throughout the building code there are three distinct use of the term assembly; assembly occupancy, assembly and assembly seating. Primarily, the portions relating to assembly occupancy establish the fire resistance associated with that Use Group. Assembly relates to a room or space where people assemble with the building code addressing life safety and accessibility requirements associated. Assembly seating relates to either seating at tables or row seating, which have unique accessibility and life safety requirements that differ from other assembly areas. This proposal clarifies the requirements associated with assembly and assembly seating from an assembly occupancy. For example, Table 1108.2.2.1 requires a wheelchair space where there are 4 fixed seats in assembly seating, an assembly occupancy requires at least 50 occupants.

The intent of this proposal is for consistency throughout the IBC. The purpose is to separate the Group A occupancy classifications used for height and area requirements, sprinklers, etc., from provisions for assembly areas where the use of the space determines the requirements (i.e., means of egress and accessibility). Sections 1028 and 1108.2 are for spaces used for assembly purposes, not just Group A buildings, therefore the text that references these provisions and included in those provisions should reflect that where appropriate.

The provisions for occupant load, seating, aisles and aisle accessways, and accessibility are associated with the use of the space (items found in Chapter 10 and 11), not the group assigned for height and area limitations, therefore, the limitation in Exception 4 to just Chapter 11 is inappropriate. This proposal also relocated Section 1017.4 that covers aisle access ways in assembly spaces with tables to Section 1028 since aisles for all assembly, including tables, are covered in Sections 1028.9 through 1028.9.6. The assistive listening and performance areas are not always associated with fixed seating. Lawn seating does not contain any fixed seating, therefore, the base paragraph should be revised to reflect the sections appropriately. Section 1028.15 is not needed since it repeats what is required in Section 1004.7.

Cost Impact: The proposal will not increase the cost of construction.

Public Hearing: Committee:	AS	AM	D
Assembly:	ASF	AMF	DF

ICCFILENAME:Roether-G1-303.1

E141-09/10

303.1, 1010.2, 1014.3, 1028 (IFC [B] 1010.2, 1014.3, 1028)

Proponent: Daniel E. Nichols, PE, New York State Dept. of State, Div. of Code Enforcement and Administration

Revise as follows:

303.1 Assembly Group A. Assembly Group A occupancy includes, among others, the use of a building or structure, or a portion thereof, for the gathering of persons for purposes such as civic, social or religious functions; recreation, food or drink consumption or awaiting transportation.

Exceptions:

1. A building or tenant space used for assembly purposes with an occupant load of less than 50 persons shall be classified as a Group B occupancy.
2. A room or space used for assembly purposes with an occupant load of less than 50 persons and accessory to another occupancy shall be classified as a Group B occupancy or as part of that occupancy.

3. A room or space used for assembly purposes that is less than 750 square feet (70m²) in area and accessory to another occupancy shall be classified as a Group B occupancy or as part of that occupancy.
4. ~~Assembly areas~~ A room or space used for assembly purposes that are accessory to Group E occupancies are not considered separate occupancies ~~except when applying the assembly occupancy requirements of Chapter 11.~~
5. Accessory religious educational rooms and religious auditoriums with occupant loads of less than 100 are not considered separate occupancies.

1010.2 (IFC [B] 1010.2) Slope. Ramps used as part of a means of egress shall have a running slope not steeper than one unit vertical in 12 units horizontal (8-percent slope). The slope of other pedestrian ramps shall not be steeper than one unit vertical in eight units horizontal (12.5-percent slope).

Exception: Aisle ramp slope in a room or space used for assembly purposes ~~occupancies of Group A or assembly occupancies accessory to Group E occupancies~~ shall comply with Section 1028.11.

1014.3 (IFC [B] 1014.3) Common path of egress travel. In occupancies other than Groups H-1, H-2 and H-3, the common path of egress travel shall not exceed 75 feet (22 860 mm). In Group H-1, H-2 and H-3 occupancies, the common path of egress travel shall not exceed 25 feet (7620 mm). For common path of egress travel in a room or space used for assembly purposes ~~Group A occupancies and assembly occupancies accessory to Group E occupancies~~ having fixed seating, see Section 1028.8.

Exceptions:

1. The length of a common path of egress travel in Group B, F and S occupancies shall not be more than 100 feet (30 480 mm), provided that the building is equipped throughout with an automatic sprinkler system installed in accordance with Section 903.3.1.1.
2. Where a tenant space in Group B, S and U occupancies has an occupant load of not more than 30, the length of a common path of egress travel shall not be more than 100 feet (30 480 mm).
3. The length of a common path of egress travel in a Group I-3 occupancy shall not be more than 100 feet (30 480 mm).
4. The length of a common path of egress travel in a Group R-2 occupancy shall not be more than 125 feet (38 100 mm), provided that the building is protected throughout with an approved automatic sprinkler system in accordance with Section 903.3.1.1 or 903.3.1.2.

**SECTION 1028
ASSEMBLY**

1028.1 (IFC [B] 1028.1) General. Occupancies in Group A and assembly occupancies accessory to ~~Group E other use groups~~ which contain seats, tables, displays, equipment or other material shall comply with this section.

1028.2 (IFC [B] 1028.2) Assembly main exit. Group A occupancies and assembly occupancies accessory to ~~Group E occupancies other use groups~~ that have an occupant load of greater than 300 shall be provided with a main exit. The main exit shall be of sufficient width to accommodate not less than one-half of the occupant load, but such width shall not be less than the total required width of all means of egress leading to the exit. ~~Where the building is classified as a Group A occupancy,~~ the main exit shall front on at least one street or an unoccupied space of not less than 10 feet (3048 mm) in width that adjoins a street or public way.

Exception: In assembly occupancies where there is no well-defined main exit or where multiple main exits are provided, exits shall be permitted to be distributed around the perimeter of the building provided that the total width of egress is not less than 100 percent of the required width.

1028.3 (IFC [B] 1028.3) Assembly other exits. In addition to having access to a main exit, each level in Group A occupancies or assembly occupancies accessory to ~~Group E occupancies other use groups~~ having an occupant load greater than 300, shall be provided with additional means of egress that shall provide an egress capacity for at least one-half of the total occupant load served by that level and comply with Section 1015.2.

Exception: In assembly occupancies where there is no well-defined main exit or where multiple main exits are provided, exits shall be permitted to be distributed around the perimeter of the building, provided that the total width of egress is not less than 100 percent of the required width.

1028.4 (IFC [B] 1028.4) Foyers and lobbies. In Group A-4A occupancies or assembly occupancies accessory to

other use groups, where persons are admitted to the building at times when seats are not available, such persons shall be allowed to wait in a lobby or similar space, provided such lobby or similar space shall not encroach upon the required clear width of the means of egress. Such foyer, if not directly connected to a public street by all the main entrances or exits, shall have a straight and unobstructed corridor or path of travel to every such main entrance or exit.

1028.5 (IFC [B] 1028.5) Interior balcony, gallery and press boxes means of egress. For balconies, galleries or press boxes having a seating capacity of 50 or more located in Group A occupancies or assembly occupancies accessory to other use groups, at least two means of egress shall be provided, with one from each side of every balcony, gallery or press box and at least one leading directly to an exit.

1028.9 (IFC [B] 1028.9) Assembly aisles are required. Every occupied portion of any occupancy in Group A or assembly occupancies accessory to ~~Group E~~ to other use groups that contains seats, tables, displays, similar fixtures or equipment shall be provided with aisles leading to exits or exit access doorways in accordance with this section. Aisle accessways for tables and seating shall comply with Section 1017.4.

Reason: The use of the accessory use section is applied to assembly areas in more than just group E occupancies. As an example, a supermarket (Group M) is permitted to be of unlimited area and is able to use up to 10% of the building area to be used as assembly space (cafeteria, restaurant) without classifying such space as a Group A. In essence, the bigger the building, the bigger the assembly area can be without providing exiting requirements. It is appropriate to provide assembly exiting provisions regardless of whether the assembly space is accessory or not.

Specific to 1028.4, waiting areas are utilized in other than Group A-1 occupancies. Examples of persons that wait in a pre-event area while the event area is still occupied (other than movies or cinemas) would be restaurants, multiple religious worship services, and changes during sporting events in tournament-style gymnasiums/arenas. This change will expand the capacity of egress when more than the assembly occupancies 'operational' capacity is within the building.

Cost Impact: The code change proposal will increase the cost of construction.

Public Hearing:	Committee:	AS	AM	D
	Assembly:	ASF	AMF	DF

ICCFILENAME:Nichols-E1-1028.1

E142-09/10

1028.1.1.1 (New) [IFC [B] 1028.1.1.1 (New)]

Proponent: Gerard A. Hathaway, RA, New York State Department of State Building Codes Division, representing self.

Add new text as follows:

1028.1.1.1 (IFC [B] 1028.1.1.1) Spaces under grandstands and bleachers. When spaces under grandstands or bleachers are used for purposes other than toilet rooms and ticket booths less than 100 sq.ft. (9.29 m²), such spaces shall be separated by fire barriers complying with Section 707 and horizontal assemblies complying with Section 712 with not less than 1-hour fire-resistance-rated construction.

Reason: The intent is to provide requirements for buildings under bleachers and grandstands that include spaces such as concessions, storage and ticket booths. The provisions are consistent with what permitted in the legacy codes. The location of this section is chosen for its proximity to the reference to the ICC 300. That way it will not be missed.

The legacy codes included provisions for spaces under seats to be kept free of combustible and flammable materials. Rooms under the bleachers were enclosed in a 1 hour fire-resistant rated construction. None of this information was passed forward into any edition of the IBC.

ICC 300, Section 305 sends you to the building and fire codes for requirements. The IBC does not include any specific provisions for this area except space over 1,000 sq.ft. must be sprinklered in accordance with Section 903.2.1.5.

From an intent point of view, the general stairway provisions (which may be viewed as similar to part of the bleacher system) require that any space under a stairway be enclosed with a 1 hour fire-resistance-rated construction (Section 1009.6.3).

Southern had –

403.6.2.2 When spaces under grandstands or bleachers are used for purposes other than toilet rooms, ticket booths less than 100 sq.ft. (9.29 m²) in area and open ramps or level exiting facilities, such spaces shall be separated by not less than 1-hour fire resistant construction.

BOCA had –

1013.8 Spaces underneath seats: Spaces underneath grandstand seats shall be kept free of all combustible and flammable materials and shall not be occupied or used for other than exits; except that where enclosed in not less than 1-hour fire resistance rated construction, the code official shall approve the use of such spaces for other purposes, provided that the safety of the public is not endangered.

ICBO had the following provisions (see the 4th paragraph for separation requirements)–

Division 4. Stadiums, reviewing stands and amusement park structures not included within other Group A Occupancies. Specific and general requirements for grandstands, bleachers and reviewing stands are to be found in Chapter 10.

303.2 Construction, Height and Allowable Area.

303.2.2 Special provisions.

303.2.2.3 Division 4 provisions. Grandstands, bleachers or reviewing stands of Type III One-hour, Type IV or Type V One-hour construction shall not exceed 40 feet (12 192 mm) to the highest level of seat boards; 20 feet (6096 mm) in cases where construction is Type III-N or Type V-N; and 12 feet (3658 mm) in cases where construction is with combustible members in the structural frame and located indoors.

Division 4 structures other than Type III-N and Type V-N grandstands, bleachers, reviewing stands and folding and telescoping seating of open skeleton-frame type without roof, cover or enclosed usable space are not limited in area or height.

Erection and structural maintenance shall conform to these special requirements as well as with other applicable provisions of this code.

When the space under a Division 4 Occupancy is used for any purpose, including means of egress, it shall be separated from all parts of such Division 4 Occupancy, including means of egress, by walls, floor and ceiling of not less than one-hour-fire-resistive construction.

EXCEPTIONS:

1. A means of egress under temporary grandstands need not be separated.
 2. The underside of continuous steel deck grandstands when erected outdoors need not be fire protected when occupied for public toilets.
- The building official may cause Division 4 structures to be reinspected at least once every six months.

Grandstands, bleachers or folding and telescoping seating may have seat boards, toeboards, bearing or base pads and footboards of combustible materials regardless of construction type.

Seating and exiting requirements for reviewing stands, grandstands, bleachers, and folding and telescoping seating are provided under Section 1008.

Cost Impact: The code change proposal will increase the cost of construction.

Public Hearing: Committee:	AS	AM	D
Assembly:	ASF	AMF	DF

ICCFILENAME:Hathaway-E1-1028.1.1.1

E143-09/10

1028.9.1 (IFC [B] 1028.9.1)

Proponent: Ed Roether, Populous (Formerly HOK Sport Venue Event), representing self

Revise as follows:

1028.9.1 (IFC [B] 1028.9.1) Minimum aisle width. The minimum clear width for aisles shall be as shown:

1. Forty-eight inches (1219 mm) for aisle stairs having seating on each side.

Exception: Thirty-six inches (914 mm) where the aisle serves less than 50 seats.

2. Thirty-six inches (914 mm) for aisle stairs having seating on only one side.

Exception: Twenty-three inches (584 mm) between an aisle stair handrail and seating where an aisle does not serve more than five rows on one side.

3. Twenty-three inches (584 mm) between an aisle stair handrail or guard and seating where the aisle is subdivided by a handrail.
4. Forty-two inches (1067 mm) for level or ramped aisles having seating on both sides.

Exceptions:

1. Thirty-six inches (914 mm) where the aisle serves less than 50 seats.
2. Thirty inches (762 mm) where the aisle does not serve more than 14 seats.

5. Thirty-six inches (914 mm) for level or ramped aisles having seating on only one side.

Exceptions:

- ~~4. Thirty inches (762 mm) where the aisle does not serve more than 14 seats.~~
- ~~2. Twenty-three inches (584 mm) between an aisle stair handrail and seating where an aisle does not serve more than five rows on one side.~~

Reason: The aisle width requirements became less clear when item #6 in the 2003 IBC became into an exception to Item #5 in the 2006 IBC, which remains in the 2009 IBC. The width of an aisle stair should not be an exception to a level or ramped aisle. Either it should be a separate item as it

was in the 2003 IBC or an exception to an aisle stair with seating on one side. This proposal relocates the current exception to the appropriate aisle stair provision to maintain the format changes that has occurred over the last several editions.

Cost Impact: This code change proposal will not increase the cost of construction.

Public Hearing: Committee:	AS	AM	D
Assembly:	ASF	AMF	DF

ICCFILENAME:Roether-E8-1025.9.1

E144-09/10

1028.9.1 (IFC [B] 1028.9.1)

Proponent: Bill Conner, representing American Society of Theatre Consultants

Revise as follows:

1028.9.1 (IFC [B] 1028.9.1) Minimum aisle width. The minimum clear width for aisles shall be as shown:

1. Forty-eight inches (1219 mm) for aisle stairs having seating on each side.

Exception: Thirty-six inches (914 mm) where the aisle serves less than 50 seats.

2. Thirty-six inches (914 mm) for aisle stairs having seating on only one side.
3. Twenty-three inches (584 mm) between an aisle stair handrail or guard and seating where the aisle is subdivided by a handrail.
4. Twenty-three inches (584 mm) between an aisle stair handrail and seating where an aisle does not serve more than five rows on one side.
- ~~4.5.~~ Forty-two inches (1067 mm) for level or ramped aisles having seating on both sides.

Exceptions:

1. Thirty-six inches (914 mm) where the aisle serves less than 50 seats.
2. Thirty inches (762 mm) where the aisle does not serve more than 14 seats.

- ~~5.6.~~ Thirty-six inches (914 mm) for level or ramped aisles having seating on only one side.

Exception Exceptions:

4. Thirty inches (762 mm) where the aisle does not serve more than 14 seats.
2. ~~Twenty-three inches (584 mm) between an aisle stair handrail and seating where an aisle does not serve more than five rows on one side.~~

Reason: This undoes a change made in the last cycle we believe was in error. First it relocates what was Item 6 to a second exception under item 5. This moved an item dealing with aisle stairs to an exception on ramped aisles. Second, the reason stated was erroneous: this exception does not duplicate point 3, which is for aisle serving seating on both sides of the aisle, but is for the specific case of serving seats on one side only. This is a special burden on smaller rooms such as black box and Alittle® theatres. The hazard is equivalent (or less because of 60 person limitation) than allowed by 1028.9.1-3. Changing the order will help clarify the original intent by grouping aisle stair requirements together.

Cost Impact: None or lower cost because of narrower aisle permitted. This aisle might otherwise have to be 36" as required by 1028.9.1-2.

Public Hearing: Committee:	AS	AM	D
Assembly:	ASF	AMF	DF

ICCFILENAME:Conner-E1-1025.9.1

E145-09/10

1028.13 (IFC [B] 1028.13)

Proponent: Bill Conner, representing American Society of Theatre Consultants

Revise as follows:

1028.13 (IFC [B] 1028.13) Handrails. Ramped aisles having a slope exceeding one unit vertical in 15 units horizontal (6.7-percent slope) and aisle stairs shall be provided with handrails located either at one or both sides of the aisle ~~the side~~ or within the aisle width.

Exceptions:

1. Handrails are not required for ramped aisles having a gradient no greater than one unit vertical in eight units horizontal (12.5-percent slope) and seating on both sides.
2. Handrails are not required if, at the side of the aisle, there is a guard that complies with the graspability requirements of handrails.
3. Handrail extensions are not required at the top and bottom of aisle stairs and aisle ramp runs to permit crossovers within the aisles.

Reason: This change simply clarifies the original intent (which I believe came from the BCMC Report on Means of Egress) that handrails could be at one side of an aisle. The plural ~~handrails~~ is sometimes interpreted as requiring them on both sides.

Cost Impact: The code change proposal will not increase the cost of construction.

Public Hearing: Committee:	AS	AM	D
Assembly:	ASF	AMF	DF

ICCFILENAME:Conner-E4-1028.13

E146-09/10

1028.13 (IFC [B] 1028.13)

Proponent: Bill Conner, representing American Society of Theatre Consultants

Revise as follows:

1028.13 (IFC [B] 1028.13) Handrails. Ramped aisles having a slope exceeding one unit vertical in 15 units horizontal (6.7-percent slope) and aisle stairs shall be provided with handrails located either at the side or within the aisle width.

Exceptions:

1. Handrails are not required for ramped aisles having a gradient no greater than one unit vertical in eight units horizontal (12.5-percent slope) and seating on both sides.
2. Handrails are not required if, at the side of the aisle, there is a guard that complies with the graspability requirements of handrails.
3. Handrail extensions are not required ~~at the top and bottom of~~ in aisle stairs and aisle ramps ~~ramp runs to permit crossovers within the aisles.~~

Reason: The change in 2009 to limit the handrail extension exemption to just the top and bottom of aisle stairs and aisle ramps is a severe restriction on design of assembly aisles. The previous edition-s exception for all handrails in aisles permitted doors and entrances to and from an aisle. Most importantly, this 2009 wording would literally require a railing extension in a handrail at the side of an aisle stair or ramp prohibiting or restricting passage to aisle accessways.

Cost Impact: The code change proposal will not increase the cost of construction.

Public Hearing: Committee:	AS	AM	D
Assembly:	ASF	AMF	DF

ICCFILENAME:Conner-E3-1028.13 ex 3

E147-09/10

1028.14.2 (IFC [B] 1028.14.2)

Proponent: Ed Roether, Populous (Formerly HOK Sport Venue Event), representing self

Revise as follows:

1028.14.2 (IFC [B] 1028.14.2) Sightline-constrained guard heights. Unless subject to the requirements of Section 1028.14.3, a fascia or railing system in accordance with the *guard* requirements of Section 1013 and having a minimum height of 26 inches (660 mm) measured vertically above the adjacent walking surfaces, adjacent bench seat or the line connecting the leading edges of the treads shall be provided where the floor or footboard elevation is more than 30 inches (762 mm) above the floor or grade below and the fascia or railing would otherwise interfere with the sightlines of immediately adjacent seating. At *bleachers*, a *guard* must be provided where required by ICC 300.

Exception: The height of the guard shall not be required to be measured vertically above an adjacent automatic or self-rising chair.

Reason: This proposal addresses several things, first it brings clarity to confusion that was created by a change that occurred in the 2009 IBC. The term "seatboard" was replaced with the term "fixed seating" in the 2009 IBC Section 1013.2 on how the height of guards are measured with the stated reason "to clarify the measurement, using common terminology". With respect to assembly seating, the term "fixed seating" does not offer greater clarity, instead it offers significantly more confusion. For example, how do you measure the height of the guard adjacent fixed seats when they are self-rising chairs? (Refer to photographs below.) In assembly seating, fixed seats refers to chairs that are secured to the structure, not that they provide a walking surface. The aisle accessway provisions of Section 1028.10 specifically address the clear width between rows of seats where there is automatic or self-rising chairs and chairs with seats that do not move. Therefore, the clarity provided other occupancies unfortunately increased confusion pertaining to assembly seating. Section 1028.14 needs to include how to measure the height of guards so that clarity can be provided assembly seating and still offer other occupancies the clarity needed for them in Section 1013.2. Please note that this proposal does not include any change to Section 1013.2, only to Section 1028.14.

Following are two photographs of self-rising chairs and one of bench seats. The fixed bench seating could serve as a walking surface, however the self-rising chairs are not easily used as a walking surface. 2007 ICC 300 measures vertically above the leading edge of the tread, adjacent walking surface or adjacent bench seat. This proposal maintains how the height of the guard is measured by 1013.2 with the exception of replacing the term "fixed seat" with the term "bench seat" to coordinate with ICC 300 and to enhance clarity that guard height needs to be measured vertically above such seats. Also, the term "bench seat" rather than "seatboard" is commonly used for this type of seating in assembly seating project specifications. An exception was added for self-rising chairs since these seats are not easily used as a walking surface and there is no well defined way to measure these chairs.

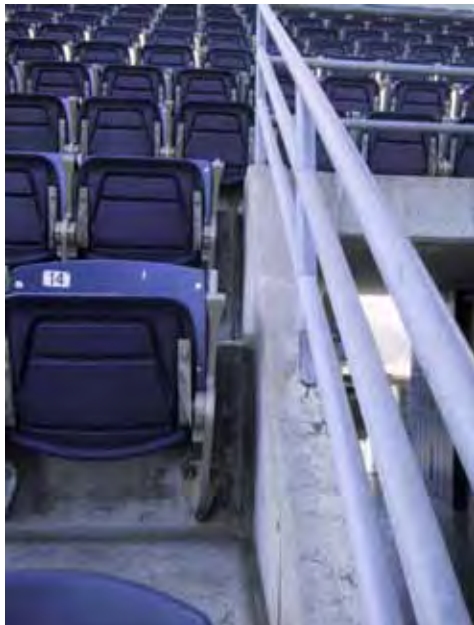



Cost Impact: This code change proposal will not increase the cost of construction.

Public Hearing:	Committee:	AS	AM	D
	Assembly:	ASF	AMF	DF

ICCFILENAME:Roether-E9-1028.14.2

E148–09/10

1028.14.2 (IFC [B] 1028.14.2)

Proponent: Bill Conner, representing American Society of Theatre Consultants

Revise as follows:

1028.14.2 (IFC [B] 1028.14.2) Sightline-constrained guard heights. Unless subject to the requirements of Section 1028.14.3, a fascia or railing system in accordance with the guard requirements of Section 1013 and having a minimum height of 26 inches (660 mm) shall be provided where the floor or footboard elevation is more than 30 inches (762 mm) above the floor or grade below and the fascia or railing would otherwise interfere with the sightlines of immediately adjacent seating. At bleachers, a guard must be provided where required by ICC 300. Sightline-constrained guard heights shall be measured vertically above the adjacent walking surfaces.

Reason: Section 1013.2 requires all guards to be A...measured vertically above the adjacent walking surfaces, adjacent fixed seating or the line connecting the leading edges of the treads.® This is not appropriate for sightline constrained rails, as the fixed seating is the reason for the exception, and measuring the 26" from the seat will obstruct sightline.

Cost Impact: The code change proposal will not increase the cost of construction.

Public Hearing:	Committee:	AS	AM	D
	Assembly:	ASF	AMF	DF

ICCFILENAME:Conner-E2-1028.14.2

E149–09/10

1028.15 (IFC [B] 1028.15)

Proponent: Bill Conner, representing American Society of Theatre Consultants

Delete without substitution:

~~**1028.15 (IFC [B] 1028.15) Bench seating.** Where bench seating is used, the number of persons shall be based on one person for each 18 inches (457 mm) of length of the bench.~~

Reason: This section should be deleted because it is redundant and contradictory with Section 1004.7

1004.7 Fixed seating. For areas having fixed seats and aisles, the occupant load shall be determined by the number of fixed seats installed therein. The occupant load for areas in which fixed seating is not installed, such as waiting spaces and wheelchair spaces, shall be determined in accordance with Section 1004.1.1 and added to the number of fixed seats.

For areas having fixed seating without dividing arms, the occupant load shall not be less than the number of seats based on one person for each 18 inches (457 mm) of seating length.

The occupant load of seating booths shall be based on one person for each 24 inches (610 mm) of booth seat length measured at the backrest of the seating booth.

Cost Impact: The code change proposal will not increase the cost of construction.

Public Hearing: Committee:	AS	AM	D
Assembly:	ASF	AMF	DF

ICCFILENAME: Conner-E5-1028.15

E150-09/10

1029.1 (IFC [B] 1029.1); IRC R310.1

Proponent: Steven Orlowski, representing National Association of Home Builders

THIS IS A 2 PART CODE CHANGE. PART I WILL BE HEARD BY THE IBC MEANS OF EGRESS COMMITTEE. PART II WILL BE HEARD BY THE IRC BUILDING/ENERGY COMMITTEE. SEE THE TENTATIVE HEARING ORDERS FOR THESE COMMITTEES.

PART I – IBC MEANS OF EGRESS

Revise as follows:

1029.1 (IFC [B] 1029.1) General. In addition to the means of egress required by this chapter, provisions shall be made for emergency escape and rescue in Group R and I-1 occupancies. Basements and sleeping rooms below the fourth story above grade plane shall have at least one exterior emergency escape and rescue opening in accordance with this section. Where basements contain one or more sleeping rooms, emergency escape and rescue openings shall be required in each sleeping room, but shall not be required in adjoining areas of the basement. Such openings shall open directly into a public way or to a yard or court that opens to a public way.

Exceptions:

1. In ~~other than Group R-3 occupancies,~~ Group R buildings equipped throughout with an approved automatic sprinkler system in accordance with Section 903.3.1.1, ~~or 903.3.1.2 or 903.3.1.3.~~
2. In other than Group R-3 occupancies, sleeping rooms provided with a door to a fire-resistance-rated corridor having access to two remote exits in opposite directions.
3. The emergency escape and rescue opening is permitted to open onto a balcony within an atrium in accordance with the requirements of Section 404, provided the balcony provides access to an exit and the dwelling unit or sleeping unit has a means of egress that is not open to the atrium.
4. Basements with a ceiling height of less than 80 inches (2032 mm) shall not be required to have emergency escape and rescue windows.
5. High-rise buildings in accordance with Section 403.
6. Emergency escape and rescue openings are not required from basements or sleeping rooms that have an exit door or exit access door that opens directly into a public way or to a yard, court or exterior exit balcony that opens to a public way.
7. Basements without habitable spaces and having no more than 200 square feet (18.6m²) in floor area shall not be required to have emergency escape windows.

PART II – IRC BUILDING/ENERGY

R310.1 Emergency escape and rescue required. Basements, habitable attics and every sleeping room shall have at least one operable emergency escape and rescue opening. Where basements contain one or more sleeping rooms, emergency egress and rescue openings shall be required in each sleeping room. Where emergency escape and rescue openings are provided they shall have a sill height of not more than 44 inches (1118 mm) above the floor. Where a door opening having a threshold below the adjacent ground elevation serves as an emergency escape and rescue opening and is provided with a bulkhead enclosure, the bulkhead enclosure shall comply with Section R310.3. The net clear opening dimensions required by this section shall be obtained by the normal operation of the emergency escape and rescue opening from the inside. Emergency escape and rescue openings with a finished sill height below

the adjacent ground elevation shall be provided with a window well in accordance with Section R310.2. Emergency escape and rescue openings shall open directly into a public way, or to a yard or court that opens to a public way.

Exception Exceptions:

1. Basements used only to house mechanical equipment and not exceeding total floor area of 200 square feet (18.58 m²).
2. Emergency escape and rescue openings shall not be required in one- and two family dwellings and townhouses that are equipped with an approved automatic sprinkler system in accordance with Section R313 or Section P2904.

Reason: Based on extensive research on the performance of residential smoke alarms, the NFPA 72 technical committee on residential alarms has determined that both ionization and photoelectric smoke alarms provide adequate escape time along the normal path of egress in both fast flaming and slow smoldering fires. In tests conducted by NIST, the results show that when smoke alarms are present and functioning properly, these devices will detect and notify the occupant with enough time to vacate the structure prior to untenable conditions being reached within the dwelling. The purpose for the emergency egress is to provide a secondary means of escape and rescue, in the event that the normal path of egress becomes blocked or conditions are unsustainable.

During the last code development cycle, the sprinkler proponents testified that residential fire sprinklers are effective in 96% of the fires that grow large enough to activate the system. With the recent addition of residential sprinklers, the time for evacuating the structure before conditions become untenable and incapacitate the occupant have been extended. When sprinklers are used in tandem with smoke alarms, the available escape time in a fast flaming fire is increased and occupants are given more time for escape. Proponents also testified that when sprinklers are present it will provide additional time for firefighters to conduct search and rescue, since the fire will be either extinguished or contained.

If homes are required to be equipped with both an active suppression system and alarm system, it is time to start reevaluating the need for some of the passive life safety features in the home that have previously been justified to protect occupants in the event of a fire. While this proposal may raise the eyebrows of many skeptics, the concept of not requiring emergency egress and rescue openings in one- and two- family dwellings equipped with an automatic suppression system is not new since this exception has been permitted in NFPA 101 The Life Safety Code for several years. In addition, the International Building Code has exempted R-1, R-2 and I-1 occupancies from requiring emergency escape and rescue openings when an approved automatic suppressions system is installed.

Cost Impact: The code change proposal will not increase the cost of construction.

PART I – IBC MEANS OF EGRESS

Public Hearing:	Committee:	AS	AM	D
	Assembly:	ASF	AMF	DF

PART II – IRC BUILDING/ENERGY

Public Hearing:	Committee:	AS	AM	D
	Assembly:	ASF	AMF	DF

ICCFILENAME:Orlowski-E1-1029.1

E151–09/10

406.2.2, [F] 907.5.2.3.4, 1007.9, 1011.3, 1022.8, 1104.4, 1106.7, 1108.2.2, 1108.2.3, 1108.4.1.1, 1108.4.1.2, 1108.4.1.4, 1108.4.1.5, 1109.1, 1109.2.1.1, 1109.2.2, 1109.2.3, 1109.3, 1109.4, 1109.6, 1109.8, 1109.13, [P] 2902.4, 3001.3, 3411.6, E104.3, E105.1, E105.2.1, E105.2.2, E105.3, E105.4, E105.6, E106.2, E106.3, E106.4, E106.4.9, E106.5, E107.2, E109.2.1, E109.2.2.1, E109.2.6, E109.2.8, E110.4; IFC 907.5.2.3.4, [B] 1007.9, [B] 1011.3, [B] 1022.8; IPC 403.4; IEBC [B] 310.6, 605.1

Proponent: Curt Wiehle, Minnesota Construction Codes and Licensing Division, representing CCLD

THIS IS A 4 PART CODE CHANGE. ALL FOUR PARTS WILL BE HEARD BY THE MEANS OF EGRESS COMMITTEE AS SEPARATE CODE CHANGES. SEE THE TENTATIVE HEARING ORDERS FOR THIS COMMITTEE.

PART I – IBC MEANS OF EGRESS

Revise as follows:

1101.2 Design. Buildings and facilities shall be designed and constructed to be accessible in accordance with this code and ICC A117.1.

SECTION 1102 DEFINITIONS

1102.1 Definitions. The following words and terms shall, for the purposes of this chapter and as used elsewhere in the code, have the meanings shown herein:

ACCESSIBLE UNIT. A dwelling unit or sleeping unit that complies with this code and the provisions for Accessible units in ICC A117.1.

TYPE A UNIT. A dwelling unit or sleeping unit designed and constructed for accessibility in accordance with this code and the provisions for Type A units in ICC A117.1.

TYPE B UNIT. A dwelling unit or sleeping unit designed and constructed for accessibility in accordance with this code and the provisions for Type B units in ICC A117.1, consistent with the design and construction requirements of the federal Fair Housing Act.

1104.4 Multilevel buildings and facilities. At least one accessible route shall connect each accessible level, including mezzanines, in multilevel buildings and facilities.

Exceptions:

1. An accessible route is not required to stories and mezzanines that have an aggregate area of not more than 3,000 square feet (278.7 m²) and are located above and below accessible levels. This exception shall not apply to:
 - 1.1. Multiple tenant facilities of Group M occupancies containing five or more tenant spaces;
 - 1.2. Levels containing offices of health care providers (Group B or I); or
 - 1.3. Passenger transportation facilities and airports (Group A-3 or B).
2. Levels that do not contain accessible elements or other spaces as determined by Section 1107 or 1108 are not required to be served by an accessible route from an accessible level.
3. In air traffic control towers, an accessible route is not required to serve the cab and the floor immediately below the cab.
4. Where a two-story building or facility has one story with an occupant load of five or fewer persons that does not contain public use space, that story shall not be required to be connected by an accessible route to the story above or below.
5. Vertical access to elevated employee work stations within a courtroom is not required at the time of initial construction, provided a ramp, lift or elevator ~~complying with ICC A117.4~~ can be installed without requiring reconfiguration or extension of the courtroom or extension of the electrical system.

1106.7 Passenger loading zones. Passenger loading zones shall be accessible ~~designed and constructed in accordance with ICC A117.1.~~

1107.2 Design. Dwelling units and sleeping units that are required to be Accessible units, Type A units and Type B units shall comply with the applicable portions of Chapter 10 of ICC A117.1. Units required to be Type A units are permitted to be designed and constructed as Accessible units. Units required to be Type B units are permitted to be designed and constructed as Accessible units or as Type A units.

1108.2.2 Wheelchair spaces. In theaters, bleachers, grandstands, stadiums, arenas and other fixed seating assembly areas, accessible wheelchair spaces ~~complying with ICC A117.4~~ shall be provided in accordance with Sections 1108.2.2.1 through 1108.2.2.4.

1108.2.3 Companion seats. At least one companion seat ~~complying with ICC A117.4~~ shall be provided for each wheelchair space required by Sections 1108.2.2.1 through 1108.2.2.3.

1108.4.1.1 Jury box. A wheelchair space ~~complying with ICC A117.4~~ shall be provided within the jury box.

Exception: Adjacent companion seating is not required.

1108.4.1.2 Gallery seating. Wheelchair spaces ~~complying with ICC A117.4~~ shall be provided in accordance with Table 1108.2.2.1. Designated aisle seats shall be provided in accordance with Section 1108.2.5.

1108.4.1.4 Employee work stations. The judge's bench, clerk's station, bailiff's station, deputy clerk's station and court reporter's station shall be located on an accessible route. The vertical access to elevated employee work stations within a courtroom is not required at the time of initial construction, provided a ramp, lift or elevator ~~complying with ICC A117.1~~ can be installed without requiring reconfiguration or extension of the courtroom or extension of the electrical system.

1108.4.1.5 Other work stations. The litigant's and counsel stations, including the lectern, shall be accessible ~~in accordance with ICC A117.1.~~

1109.1 General. Accessible building features and facilities shall be provided in accordance with Sections 1109.2 through 1109.14.

Exception: Accessible units. Type A units and Type B units shall comply with Chapter 10 of ICC A117.1.

1109.2 Toilet and bathing facilities. Each toilet room and bathing room shall be *accessible*. Where a floor level is not required to be connected by an *accessible route*, the only toilet rooms or bathing rooms provided within the facility shall not be located on the inaccessible floor. At least one of each type of fixture, element, control or dispenser in each *accessible* toilet room and bathing room shall be *accessible*.

Exceptions:

1. In toilet rooms or bathing rooms accessed only through a private office, not for *common* or *public use* and intended for use by a single occupant, any of the following alternatives are allowed:
 - 1.1. Doors are permitted to swing into the clear floor space, provided the door swing can be reversed to meet the requirements in ICC A117.1;
 - 1.2. The height requirements for the water closet in ICC A117.1 are not applicable;
 - 1.3. Grab bars are not required to be installed in a toilet room, provided that reinforcement has been installed in the walls and located so as to permit the installation of such grab bars; and
 - 1.4. The requirement for height, knee and toe clearance shall not apply to a lavatory.
2. This section is not applicable to toilet and bathing rooms that serve *dwelling units* or *sleeping units* that are not required to be *accessible* by Section 1107.
3. Where multiple single-user toilet rooms or bathing rooms are clustered at a single location, at least 50 percent but not less than one room for each use at each cluster shall be *accessible*.
4. Where no more than one urinal is provided in a toilet room or bathing room, the urinal is not required to be *accessible*.
5. Toilet rooms that are part of critical care or intensive care patient sleeping rooms are not required to be *accessible*.

1109.2.1.1 Standard. Family or assisted-use toilet and bathing rooms shall comply with Sections 1109.2.1.2 through 1109.2.1.7 ~~and ICC A117.1.~~

1109.2.2 Water closet compartment. Where water closet compartments are provided in a toilet room or bathing facility, at least one wheelchair-accessible compartment shall be provided. Where the combined total water closet compartments and urinals provided in a toilet room or bathing facility is six or more, at least one ambulatory-accessible water closet compartment shall be provided in addition to the wheelchair-accessible compartment. ~~Wheelchair-accessible and ambulatory-accessible compartments shall comply with ICC A117.1.~~

1109.2.3 Lavatories. Where lavatories are provided, at least 5 percent, but not less than one, shall be *accessible*. Where the total lavatories provided in a toilet room or bathing facility is six or more, at least one lavatory with enhanced reach ranges ~~in accordance with ICC A117.1,~~ shall be provided.

1109.3 Sinks. Where sinks are provided, at least 5 percent but not less than one provided in accessible spaces shall be *accessible* ~~comply with ICC A117.1.~~

Exception: Mop or service sinks are not required to be accessible.

1109.4 Kitchens and kitchenettes. Where kitchens and kitchenettes are provided in accessible spaces or rooms, they shall be accessible ~~in accordance with ICC A117.1.~~

1109.6 Elevators. Passenger elevators on an accessible route shall be accessible and comply with ~~Section 3001.3~~ Chapter 30.

1109.8 Storage. Where fixed or built-in storage elements such as cabinets, shelves, medicine cabinets, closets and drawers are provided in required accessible spaces, at least one of each type shall contain accessible storage space ~~complying with ICC A117.1.~~

1109.13 Fuel-dispensing systems. Fuel-dispensing systems shall be accessible ~~comply with ICC A117.1.~~

SECTION 406 MOTOR-VEHICLE-RELATED OCCUPANCIES

406.2.2 Clear height. The clear height of each floor level in vehicle and pedestrian traffic areas shall not be less than 7 feet (2134 mm). Vehicle and pedestrian areas accommodating van-accessible parking shall comply with ~~required by~~ Section 1106.5 ~~shall conform to ICC A117.1.~~

SECTION 1007 (IFC [B] 1007) ACCESSIBLE MEANS OF EGRESS

1007.9 (IFC [B] 1007.9) Signage. Signage indicating special accessibility provisions shall be provided as shown:

1. Each door providing access to an *area of refuge* from an adjacent floor area shall be identified by a sign stating: AREA OF REFUGE.
2. Each door providing access to an exterior area for assisted rescue shall be identified by a sign stating: EXTERIOR AREA FOR ASSISTED RESCUE.

Signage shall comply with the ICC A117.1 requirements for visual characters and include the International Symbol of Accessibility. Where exit sign illumination is required by Section 1011.2, the signs shall be illuminated. Additionally, raised character and braille ~~tactile~~ signage complying with ICC A117.1 shall be located at each door to an *area of refuge* and exterior area for assisted rescue in accordance with Section 1011.3.

SECTION 1010 (IFC [B] 1010) RAMPS

1010.1 (IFC [B] 1010.1) Scope. The provisions of this section shall apply to ramps used as a component of a means of egress.

Exceptions:

1. Other than ramps that are part of the accessible routes providing access in accordance with Sections 1108.2 through 1108.2.4 and 1108.2.6, ramped aisles within assembly rooms or spaces shall conform with the provisions in Section 1028.11.
2. Curb ramps shall comply with ICC A117.1.
3. Vehicle ramps in parking garages for pedestrian exit access shall not be required to comply with Sections 1010.3 through 1010.9 when they are not an accessible route serving accessible parking spaces, other required accessible elements or part of an accessible means of egress.

1010.6.5 (IFC [B] 1010.6.5) Doorways. Where doorways are located adjacent to a ramp landing, maneuvering clearances required by ICC A117.1 are permitted to overlap the required landing area.

1010.9 (IFC [B] 1010.9) Edge protection. Edge protection complying with Section 1010.9.1 or 1010.9.2 shall be provided on each side of ramp runs and at each side of ramp landings.

Exceptions:

1. Edge protection is not required on ramps that are not required to have handrails, provided they have flared sides that comply with the ICC A117.1 curb ramp provisions.
2. Edge protection is not required on the sides of ramp landings serving an adjoining ramp run or stairway.
3. Edge protection is not required on the sides of ramp landings having a vertical drop off of not more than ½ inch (12.7 mm) within 10 inches (254 mm) horizontally of the required landing area.
4. In assembly spaces with fixed seating, edge protection is not required on the sides of ramps where the ramps provide access to the adjacent seating and aisle accessways.

**SECTION 1011(IFC [B] 1011)
EXIT SIGNS**

1011.3 (IFC [B] 1011.3) Tactile Raised character and Braille exit signs. A tactile sign stating EXIT in raised characters and Braille and complying with ICC A117.1 shall be provided adjacent to each door to an area of refuge, an exterior area for assisted rescue, an exit stairway, an exit ramp, an exit passageway and the exit discharge.

**SECTION 1022 (IFC [B] 1022)
EXIT ENCLOSURES**

1022.8 (IFC [B] 1022.8) Floor identification signs. A sign shall be provided at each floor landing in exit enclosures connecting more than three stories designating the floor level, the terminus of the top and bottom of the exit enclosure and the identification of the stair or ramp. The signage shall also state the story of, and the direction to, the exit discharge and the availability of roof access from the enclosure for the fire department. The sign shall be located 5 feet (1524 mm) above the floor landing in a position that is readily visible when the doors are in the open and closed positions. In addition, floor level identification signs in tactile raised characters and Braille complying with ICC A117.1 shall be located at each floor level landing adjacent to the door leading from the enclosure into the corridor to identify the floor level.

**CHAPTER 30
ELEVATORS AND CONVEYING SYSTEMS**

3001.3 Accessibility. ~~Passenger elevators required to be accessible by Chapter 11 shall conform to ICC A117.1 or serve as part of an accessible means of egress shall comply with Section 1107 and 1109.6.~~

3008.13.1 Design and installation. The two-way communication system shall include audible and visible signals and shall be designed and installed in accordance with the requirements in ICC A117.1.

3008.13.2 Instructions. Instructions for the use of the two-way communication system along with the location of the station shall be permanently located adjacent to each station. Signage shall comply with the ICC A117.1 requirements for visual characters.

**SECTION 3411 (IEBC 310)
ACCESSIBILITY FOR EXISTING BUILDINGS**

3411.6 (IEBC 310.6) Alterations. A building, facility or element that is altered shall comply with the applicable provisions in Chapter 11 of this code ~~and ICC A117.1~~, unless technically infeasible. Where compliance with this section is technically infeasible, the alteration shall provide access to the maximum extent technically feasible.

Exceptions:

1. The altered element or space is not required to be on an accessible route, unless required by Section 3411.7.
2. Accessible means of egress required by Chapter 10 are not required to be provided in existing buildings and facilities.
3. The alteration to Type A individually owned dwelling units within a Group R-2 occupancy shall be permitted to meet the provision for a Type B dwelling unit ~~and shall comply with the applicable provisions in Chapter 11 and ICC A117.1.~~

3411.8.2 (IEBC 310.8.2) Elevators. Altered elements of existing elevators shall comply with ASME A17.1 and ICC A117.1. Such elements shall also be altered in elevators programmed to respond to the same hall call control as the altered elevator.

3411.8.3 (IEBC 310.8.3) Platform lifts. Platform (wheelchair) lifts complying with ICC A117.1 and installed in accordance with ASME A18.1 shall be permitted as a component of an accessible route.

**APPENDIX E
SUPPLEMENTARY ACCESSIBILITY REQUIREMENTS**

E101.2 Design. Technical requirements for items herein shall comply with this code and ICC A117.1.

SECTION E104 SPECIAL OCCUPANCIES

E104.2 Accessible beds. In rooms or spaces having more than 25 beds, 5 percent of the beds shall have a clear floor space complying with ICC A117.1.

E104.2.1 Sleeping areas. A clear floor space complying with ICC A117.1 shall be provided on both sides of the accessible bed. The clear floor space shall be positioned for parallel approach to the side of the bed.

Exception: This requirement shall not apply where a single clear floor space complying with ICC A117.1 positioned for parallel approach is provided between two beds.

E104.3 Communication features. Accessible communication features complying with ICC A117.1 shall be provided in accordance with Sections E104.3.1 through E104.3.4.

E104.3.4 Notification devices. Visual notification devices shall be provided to alert room occupants of incoming telephone calls and a door knock or bell. Notification devices shall not be connected to visual alarm signal appliances. Permanently installed telephones shall have volume controls and an electrical outlet complying with ICC A117.1 located within 48 inches (1219 mm) of the telephone to facilitate the use of a TTY.

SECTION E105 OTHER FEATURES AND FACILITIES

E105.1 Portable toilets and bathing rooms. Where multiple single-user portable toilet or bathing units are clustered at a single location, at least 5 percent, but not less than one toilet unit or bathing unit at each cluster, shall be accessible ~~comply with ICC A117.1~~. Signs containing the International Symbol of Accessibility ~~and complying with ICC A117.1~~ shall identify accessible portable toilets and bathing units.

Exception: Portable toilet units provided for use exclusively by construction personnel on a construction site.

E105.2.1 Washing machines. Where three or fewer washing machines are provided, at least one shall be accessible ~~comply with ICC A117.1~~. Where more than three washing machines are provided, at least two shall be accessible ~~comply with ICC A117.1~~.

E105.2.2 Clothes dryers. Where three or fewer clothes dryers are provided, at least one shall be accessible ~~comply with ICC A117.1~~. Where more than three clothes dryers are provided, at least two shall be accessible ~~comply with ICC A117.1~~.

E105.3 Depositories, vending machines, change machines and similar equipment. Where provided, at least one of each type of depository, vending machine, change machine and similar equipment shall be accessible ~~comply with ICC A117.1~~.

Exception: Drive-up-only depositories are not required to comply with this section.

E105.4 Mailboxes. Where mailboxes are provided in an interior location, at least 5 percent, but not less than one, of each type shall be accessible ~~comply with ICC A117.1~~. In residential and institutional facilities, where mailboxes are provided for each dwelling unit or sleeping unit, mailboxes be accessible ~~complying with ICC A117.1~~ shall be provided for each unit required to be an Accessible unit.

E105.6 Two-way communication systems. Where two-way communication systems are provided to gain admittance to a building or facility or to restricted areas within a building or facility, the system shall be accessible ~~comply with ICC A117.1~~.

SECTION E106 TELEPHONES

E106.2 Wheelchair-accessible telephones. Where public telephones are provided, wheelchair-accessible telephones ~~complying with ICC A117.1~~ shall be provided in accordance with Table E106.2.

Exception: Drive-up-only public telephones are not required to be accessible.

E106.3 Volume controls. All public telephones provided shall have accessible volume control ~~complying with ICC A117.1.~~

E106.4 TTYs. TTYs ~~complying with ICC A117.1~~ shall be provided in accordance with Sections E106.4.1 through E106.4.9.

E106.4.9 Signs. Public TTYs shall be identified by the International Symbol of TTY ~~complying with ICC A117.1.~~ Directional signs indicating the location of the nearest public TTY shall be provided at banks of public pay telephones not containing a public TTY. Additionally, where signs provide direction to public pay telephones, they shall also provide direction to public TTYs. Such signs shall comply with visual signage requirements in ICC A117.1 and shall include the International Symbol of TTY.

E106.5 Shelves for portable TTYs. Where a bank of telephones in the interior of a building consists of three or more public pay telephones, at least one public pay telephone at the bank shall be provided with a shelf and an electrical outlet ~~in accordance with ICC A117.1.~~

Exceptions:

1. In secured areas of detention and correctional facilities, if shelves and outlets are prohibited for purposes of security or safety shelves and outlets for TTYs are not required to be provided.
2. The shelf and electrical outlet shall not be required at a bank of telephones with a TTY.

**SECTION E107
SIGNAGE**

E107.1 Signs. Required accessible portable toilets and bathing facilities shall be identified by the International Symbol of Accessibility.

E107.2 Designations. Interior and exterior signs identifying permanent rooms and spaces shall be tactile raised characters and braille. Where pictograms are provided as designations of interior rooms and spaces, the pictograms shall have tactile raised character and braille text descriptors. ~~Signs required to provide tactile characters and pictograms shall comply with ICC A117.1.~~

Exceptions:

1. Exterior signs that are not located at the door to the space they serve are not required to comply.
2. Building directories, menus, seat and row designations in assembly areas, occupant names, building addresses and company names and logos are not required to comply.
3. Signs in parking facilities are not required to comply.
4. Temporary (seven days or less) signs are not required to comply.
5. In detention and correctional facilities, signs not located in public areas are not required to comply.

E107.3 Directional and informational signs. Signs that provide direction to, or information about, permanent interior spaces of the site and facilities shall contain visual characters complying with ICC A117.1.

Exception: Building directories, personnel names, company or occupant names and logos, menus and temporary (seven days or less) signs are not required to comply with ICC A117.1.

**SECTION E108
BUS STOPS**

E108.3 Bus shelters. Where provided, new or replaced bus shelters shall provide a minimum clear floor or ground space complying with ICC A117.1, Section 305, entirely within the shelter. Such shelters shall be connected by an accessible route to the boarding area required by Section E108.2.

E108.4 Signs. New bus route identification signs shall have finish and contrast complying with ICC A117.1. Additionally, to the maximum extent practicable, new bus route identification signs shall provide visual characters complying with ICC A117.1.

Exception: Bus schedules, timetables and maps that are posted at the bus stop or bus bay are not required to meet this requirement.

SECTION E109 TRANSPORTATION FACILITIES AND STATIONS

E109.2.1 Station entrances. Where different entrances to a station serve different transportation fixed routes or groups of fixed routes, at least one entrance serving each group or route shall comply with Section 1104 and ICC A117.1.

E109.2.2.1 Tactile Raised character and braille signs. Where signs are provided at entrances to stations identifying the station or the entrance, or both, at least one sign at each entrance shall be tactile raised characters and braille. A minimum of one tactile raised character and braille sign identifying the specific station shall be provided on each platform or boarding area. Such signs shall be placed in uniform locations at entrances and on platforms or boarding areas within the transit system to the maximum extent practicable. ~~Tactile signs shall comply with ICC A117.1.~~

Exceptions:

1. Where the station has no defined entrance but signs are provided, the tactile raised character and braille signs shall be placed in a central location.
2. Signs are not required to be tactile raised character and braille where audible signs are remotely transmitted to hand-held receivers, or are user or proximity actuated.

E109.2.2.2 Identification signs. Stations covered by this section shall have identification signs containing visual characters complying with ICC A117.1. Signs shall be clearly visible and within the sightlines of a standing or sitting passenger from within the train on both sides when not obstructed by another train.

E109.2.2.3 Informational signs. Lists of stations, routes and destinations served by the station which are located on boarding areas, platforms or mezzanines shall provide visual characters complying with ICC A117.1. Signs covered by this provision shall, to the maximum extent practicable, be placed in uniform locations within the transit system.

E109.2.3 Fare machines. Self-service fare vending, collection and adjustment machines shall comply with ICC A117.1, Section 707. Where self-service fare vending, collection or adjustment machines are provided for the use of the general public, at least one accessible machine of each type provided shall be provided at each accessible point of entry and exit.

E109.2.5 TTYs. Where a public pay telephone is provided in a transit facility (as defined by the Department of Transportation) at least one public TTY complying with ICC A117.1, Section 704.4, shall be provided in the station. In addition, where one or more public pay telephones serve a particular entrance to a transportation facility, at least one TTY telephone complying with ICC A117.1, Section 704.4, shall be provided to serve that entrance.

E109.2.6 Track crossings. Where a circulation path serving boarding platforms crosses tracks, an accessible route ~~complying with ICC A117.1~~ shall be provided.

Exception: Openings for wheel flanges shall be permitted to be 2 1/2 inches (64 mm) maximum.

E109.2.8 Clocks. Where clocks are provided for use by the general public, the clock face shall be uncluttered so that its elements are clearly visible. Hands, numerals and digits shall contrast with the background either light-on-dark or dark-on-light. Where clocks are mounted overhead, numerals and digits shall comply with visual character requirements ICC A117.1, Section 703.2.

SECTION E110 AIRPORTS

E110.2 TTYs. Where public pay telephones are provided, at least one TTY shall be provided in compliance with ICC A117.1, Section 704.4. Additionally, if four or more public pay telephones are located in a main terminal outside the security areas, a concourse within the security areas or a baggage claim area in a terminal, at least one public TTY complying with ICC A117.1, Section 704.4, shall also be provided in each such location.

E110.4 Clocks. Where clocks are provided for use by the general public, the clock face shall be uncluttered so that its elements are clearly visible. Hands, numerals and digits shall contrast with their background either light-on-dark or dark-on-light. Where clocks are mounted overhead, numerals and digits shall comply with visual character requirements ICC A117.1, Section 703.2.

PART II – IFC

Revise as follows:

SECTION [F] 907 (IFC 907) FIRE ALARM AND DETECTION SYSTEMS

[F] 907.5.2.3.4 (IFC 907.5.2.3.4) Group R-2. In Group R-2 occupancies required by Section 907 to have a fire alarm system, all dwelling units and sleeping units shall be provided with the capability to support visible alarm notification appliances in accordance with Chapter 10 of ICC A117.1.

PART III – IPC

Revise 2902.4 to match IPC 403.4 as follows:

SECTION [P] 2902 (IPC 403.4) MINIMUM PLUMBING FACILITIES

[P] 2902.4 Signage. ~~A legible sign designating the sex shall be provided in a readily visible location near the entrance to each toilet facility.~~ Required public facilities shall be designated by a legible sign for each sex. Signs shall be readily visible and located near the entrance to each toilet facility. Signs for accessible toilet facilities shall comply with Section 1110 ICC A117.1.

IPC 403.4 Signage. Required *public* facilities shall be designated by a legible sign for each sex. Signs shall be readily visible and located near the entrance to each toilet facility. Signs for accessible toilet facilities shall comply with Section 1110 of the *International Building Code*.

PART IV – IEBC

SECTION 605 ACCESSIBILITY

605.1 General. A building, facility or element that is altered shall comply with the applicable provisions in Sections 605.1.1 through 605.1.14, Chapter 11 of the International Building Code ~~and ICC A117.1~~ unless it is technically infeasible. Where compliance with this section is technically infeasible, the alteration shall provide access to the maximum extent that is technically feasible. A building, facility or element that is constructed or altered to be accessible shall be maintained accessible during occupancy.

Exceptions:

1. The altered element or space is not required to be on an accessible route unless required by Section 605.2.
2. Accessible means of egress required by Chapter 10 of the International Building Code are not required to be provided in existing buildings and facilities.
3. Type B dwelling or sleeping units required by Section 1107 of the International Building Code are not required to be provided in existing buildings and facilities.
4. The alteration to Type A individually owned dwelling units within a Group R-2 occupancy shall be permitted to meet the provisions for Type B dwelling units ~~and shall comply with the applicable provisions in Chapter 11 of the International Building Code and ICC A117.1.~~

605.1.2 Elevators. Altered elements of existing elevators shall comply with ASME A17.1 and ICC A117.1. Such elements shall also be altered in elevators programmed to respond to the same hall call control as the altered elevator.

605.1.3 Platform lifts. Platform (wheelchair) lifts complying with ICC A117.1 and installed in accordance with ASME A18.1 shall be permitted as a component of an accessible route.

Reason:

PART I-IBC

Section 1101.2 establishes ICC A117.1 as the standard for accessible design for Chapter 11. Section E101.2 establishes ICC A117.1 as the standard for accessible design for Appendix E. It is unnecessary to repeat this throughout Chapter 11 or Appendix E unless the specific text is an exception to the standard (Ex: Section 1109.2 Ex. 1) or a specific item within the standard (Ex: Section 1002.1, Definitions for Accessible Unit, Type

A unit and Type B unit) . Providing the reference in a haphazard manner within the chapter only serves to create confusion. This is an editorial issue and the editorial committee should verify that there are not other occurrences of this in the chapter. The text provided shows all of the location where ICC A117.1 is currently referenced.

1109.1 – The revisions is correlative with the 2003 A117.1 including Accessible Units in Chapter 10 which only included Type A and Type B units in the 1998 edition. The definition for Accessible units was correlated and approved with the new edition, but this exception was missed.

1109.6 – the reference to Section 3001.3 is only a reference to ICC A117.1, which is not needed since it is already called out in Section 1101.2. All elevators have to comply with Chapter 30 for safety.

406.2.2 – the reference to Section 1106.5 for accessible parking automatically gets ICC A117.1.

1007.9 – ICC A117.1 has changed ‘tactile’ requirements for signage to ‘raised characters and braille’. This revision would correlate with the standard.

1011.3 – ICC A117.1 has changed ‘tactile’ requirements for signage to ‘raised characters and braille’. This revision would correlate with the standard.

3411.6 (IEBC 310.6) - The reference to IBC Chapter 11 already gets the ICC A117.1.

Changes for ‘tactile characters’ to ‘raised characters and braille’ is consistent with revisions to the 2009 edition in A117.1.

Part II – IFC - 907.5.2.3.4 – in this situation, the more specific reference would clarify to users where the alarm requirements for dwelling units are found. This would be consistent with the definitions of Accessible units, Type A units and Type B units.

Part III – IPC – 2902.4 (IPC 403.4) – The reference to the signage requirements in Chapter 11 will help a user locate all the provisions for accessible signage associated with toilet rooms and in addition will pick up the ICC A117.1 references. The signage requirements in Chapter 29 should match the Plumbing Code requirements.

Part IV – IEBC – 605.1 – The reference to IBC Chapter 11 already gets the ICC A117.1.

Cost Impact: The code change proposal will not increase the cost of construction.

PART I – IBC MEANS OF EGRESS

Public Hearing:	Committee:	AS	AM	D
	Assembly:	ASF	AMF	DF

PART II – IFC

Public Hearing:	Committee:	AS	AM	D
	Assembly:	ASF	AMF	DF

PART III – IPC

Public Hearing:	Committee:	AS	AM	D
	Assembly:	ASF	AMF	DF

PART IV – IEBC

Public Hearing:	Committee:	AS	AM	D
	Assembly:	ASF	AMF	DF

ICCFILENAME:Wiehle-E8-1101.2

E152–09/10

1102.1, 1104.2, 1104.3, 1109.7, 1109.14, 1110 (New), 3411.8, 3411.8.15 (New), 3411.8.16 (New) [IEBC [B] 310.8, 310.8.15 (New), 310.8.16 (New); IEBC 605.1, 605.1.15 (New), 605.1.16 (New)

Proponent: Marsha K. Mazz, U.S. Architectural and Transportation Barriers Compliance Board (Access Board)

THIS IS A 2 PART CODE CHANGE. BOTH PARTS WILL BE HEARD BY THE IBC MEANS OF EGRESS COMMITTEE AS 2 SEPARATE CODE CHANGES. SEE THE TENTATIVE HEARING ORDER FOR THE THIS COMMITTEE.

PART I – IBC MEANS OF EGRESS

1. Add new definitions as follows:

1102.1 Definitions. The following words and terms shall, for the purposes of this chapter and as used elsewhere in the code, have the meanings shown herein:

AMUSEMENT RIDE. A system that moves persons through a fixed course within a defined area for the purpose of amusement.

AMUSEMENT RIDE SEAT. A seat that is built-in or mechanically fastened to an amusement ride intended to be occupied by one or more passengers.

AREA OF SPORT ACTIVITY. That portion of a room or space where the play or practice of a sport occurs.

BOARDING PIER. A portion of a pier where a boat is temporarily secured for the purpose of embarking or disembarking.

BOAT LAUNCH RAMP. A sloped surface designed for launching and retrieving trailered boats and other water craft to and from a body of water.

BOAT SLIP. That portion of a pier, main pier, finger pier, or float where a boat is moored for the purpose of berthing, embarking, or disembarking.

GANGWAY. A variable-sloped pedestrian walkway that links a fixed structure or land with a floating structure. Gangways which connect to vessels are not included.

GOLF CAR PASSAGE. A continuous passage on which a motorized golf car can operate.

PLAY AREA. A portion of a site containing play components designed and constructed for children.

PLAY COMPONENT. An element intended to generate specific opportunities for play, socialization, or learning. Play components may be manufactured or natural, and may be stand alone or part of a composite play structure.

TEEING GROUND. In golf, the starting place for the hole to be played.

TRANSFER DEVICE. Equipment designed to facilitate the transfer of a person from a wheelchair or other mobility device to and from an amusement ride seat.

2. Revise as follows:

1104.2 Within a site. At least one accessible route shall connect accessible buildings, accessible facilities, accessible elements and accessible spaces that are on the same site.

Exceptions:

1. An accessible route is not required between accessible buildings, accessible facilities, accessible elements and accessible spaces that have, as the only means of access between them, a vehicular way not providing for pedestrian access.
2. An accessible route to recreational facilities is not required when exempted under Sections 1110.4 or 1110.6

1104.3 Connected spaces. When a building or portion of a building is required to be accessible, an accessible route shall be provided to each portion of the building, to accessible building entrances connecting accessible pedestrian walkways and the public way.

Exceptions:

1. In assembly areas with fixed seating, an accessible route shall not be required to serve levels where wheelchair spaces are not provided.
2. In Group I-2 facilities, doors to sleeping units shall be exempted from the requirements for maneuvering clearance at the room side provided the door is a minimum of 44 inches (1118 mm) in width.
3. An accessible route to recreational facilities is not required when exempted under Sections 1110.4 or 1110.6

1109.7 Lifts. Platform (wheelchair) lifts are permitted to be a part of a required accessible route in new construction where indicated in Items 1 through ~~40~~ 11. Platform (wheelchair) lifts shall be installed in accordance with ASME A18.1.

1. An accessible route to a performing area and speaker platforms in Group A occupancies.

2. An accessible route to wheelchair spaces required to comply with the wheelchair space dispersion requirements of Sections 1108.2.2 through 1108.2.6.
3. An accessible route to spaces that are not open to the general public with an occupant load of not more than five.
4. An accessible route within a dwelling or sleeping unit.
5. An accessible route to wheelchair seating spaces located in outdoor dining terraces in Group A-5 occupancies where the means of egress from the dining terraces to a public way are open to the outdoors.
6. An accessible route to jury boxes and witness stands; raised courtroom stations including judges' benches, clerks' stations, bailiffs' stations, deputy clerks' stations and court reporters' stations; and to depressed areas such as the well of the court.
7. An accessible route to load and unload areas serving amusement rides.
8. An accessible route to play components or soft contained play structures.
9. An accessible route to team or player seating areas serving areas of sport activity.
10. An accessible route where existing exterior site constraints make use of a ramp or elevator infeasible.
11. Platform lifts shall be permitted to be used instead of gangways that are part of accessible routes serving recreational boating facilities and fishing piers and platforms.

SECTION 1110 **RECREATIONAL FACILITIES**

1110.1 ~~4409.14~~ Recreational and sports facilities. Recreational and sports facilities shall be provided with accessible features in accordance with Sections 1110.2 ~~4409.14.4~~ through 1110.6 ~~4409.14.4~~.

1110.2 ~~4409.14.1~~ Facilities serving Type B units in a single building. In Group R-2 and R-3 occupancies where recreational facilities are provided serving a single building containing ~~Type A units or~~ Type B units, 25 percent, but not less than one, of each type of recreational facility shall be accessible. Every recreational facility of each type on a site shall be considered to determine the total number of each type that is required to be accessible.

1110.3 ~~4409.14.2~~ Facilities serving Type B units in multiple buildings. In Group R-2 and R-3 occupancies on a single site where multiple buildings containing ~~Type A units or~~ Type B units are served by recreational facilities, 25 percent, but not less than one, of each type of recreational facility serving each building shall be accessible. The total number of each type of recreational facility that is required to be accessible shall be determined by considering every recreational facility of each type serving each building on the site.

1110.4 Facilities serving Accessible and Type A units. In Group R-2 and R-3 occupancies where recreational facilities are provided serving Accessible or Type A units, every recreational facility of each type serving Accessible or Type A units shall be accessible.

1110.5 ~~4409.14.3~~ Other occupancies. All recreational facilities not falling within the purview of Section 1110.2 through 1110.4 ~~4409.14.1 or 4409.14.2~~ shall comply with ICC A117.1 and be located on an accessible route be accessible. Each area of sports activity shall be served by an accessible route. Accessible route shall also comply with Section 1110.5.1 through 1110.5.3.

Exception: Areas of sport activity shall not be required to comply with ICC A117.1.

1110.5.1 Protruding objects. Protruding objects shall comply with the requirements of Sections 1003.3.

Exception: Within play areas, protruding objects on circulation paths shall not be required to comply with 1003.3 provided that ground level accessible routes provide vertical clearance in compliance with 1003.3.1.

1110.5.2 Floor surface. Walking surfaces of the accessible route shall comply with ICC ANSI A117.1.

Exception: Within animal containment areas, floor and ground surfaces shall not be required to be stable, firm, and slip resistant.

1110.5.3 Changes in Level. Where changes in level are permitted in floor or ground surfaces, they shall comply with ICC A117.1 for changes in level.

Exception: Animal containment areas shall not be required to comply with ICC A117.1.

1110.6 ~~1109.14.4~~ Recreational and sports facilities exceptions. Recreational and sports facilities required to be accessible shall be exempt from this chapter to the extent specified in this section.

1110.6.1 ~~1108.2.2.4~~ Team or player seating. At least one wheelchair space shall be provided in team or player seating areas serving areas of sport activity.

Exception: Wheelchair spaces shall not be required in team or player seating areas serving bowling lanes that are not required to be located on an accessible route in accordance with Section ~~1109.14.4.4~~ 1110.6.2.

1110.6.2 ~~1109.14.4.1~~ Bowling lanes. An accessible route shall be provided to at least 5 percent, but no less than one, of each type of bowling lane.

1110.6.3 ~~1109.14.4.2~~ Court sports. In court sports, at least one accessible route shall directly connect both sides of the court.

1110.6.4 ~~1109.14.4.3~~ Raised boxing or wrestling rings. Raised boxing or wrestling rings are not required to be accessible or to be on an accessible route.

1110.6.5 ~~1109.14.4.4~~ Raised refereeing, judging and scoring areas. Raised structures used solely for refereeing, judging or scoring a sport are not required to be accessible or to be on an accessible route.

1110.6.6 Swimming pools, wading pools and spas. Swimming pools, wading pools, and spas shall comply with ICC A117.1.

1110.6.6.1 ~~1109.14.4.5~~ Raised diving boards and diving platforms. Raised diving boards and diving platforms are not required to be accessible or to be on an accessible route.

1110.6.6.2 Water Slides. Water slides are not be required to be accessible or to be on an accessible route.

1110.6.7 Amusement Rides. Amusement rides shall comply with Section 1110.6.7.1 through 1110.6.7.3.

Exception: Mobile or portable amusement rides shall not be required to be accessible.

1110.6.7.1 Load and Unload Areas. Load and unload areas serving amusement rides shall comply with ICC A117.1.

1110.6.7.2 Minimum Number. Amusement rides shall provide at least one wheelchair space, or at least one amusement ride seat designed for transfer, or at least one transfer device.

Exceptions:

1. Amusement rides that are controlled or operated by the rider shall not be required to comply with this section.
2. Amusement rides designed primarily for children, where children are assisted on and off the ride by an adult, shall not be required to comply with this section.
3. Amusement rides that do not provide amusement ride seats shall not be required to comply with this section.

1110.6.7.3 Amusement Rides. Accessible amusement rides shall be on an accessible routes in accordance with Section 1110.6.7.3.1 and 1110.6.7.3.2.

1110.6.7.3.1 Load and Unload Areas. Load and unload areas shall be on an accessible route. Where load and unload areas have more than one loading or unloading position, at least one loading and unloading position shall be on an accessible route.

1110.6.7.3.2 Wheelchair Spaces, Ride Seats Designed for Transfer, and Transfer Devices. When amusement rides are in the load and unload position, wheelchair spaces, amusement ride seats designed for transfer and transfer devices shall be on an accessible route.

1110.6.8 Recreational Boating Facilities. Boat slips required to be accessible by Section 1110.6.8.1 and 1110.6.8.2 and boarding piers at boat launch ramps required to be accessible by Section 1110.6.8.3 shall be on an accessible route.

1110.6.8.1 Boat Slips. Boat slips complying with ICC A117.1 shall be provided in accordance with Table 1110.6.8.1. Where the number of boat slips is not identified, each 40 feet (12 m) of boat slip edge provided along the perimeter of the pier shall be counted as one boat slip for the purpose of this section.

**TABLE 1110.6.8.1
BOAT SLIPS**

<u>Total Number of Boating Slips Provided in Facility</u>	<u>Minimum Number of Required Accessible Boating Slips</u>
<u>1 to 25</u>	<u>1</u>
<u>26 to 50</u>	<u>2</u>
<u>51 to 100</u>	<u>3</u>
<u>101 to 150</u>	<u>4</u>
<u>151 to 300</u>	<u>5</u>
<u>301 to 400</u>	<u>6</u>
<u>401 to 500</u>	<u>7</u>
<u>501 to 600</u>	<u>8</u>
<u>601 to 700</u>	<u>9</u>
<u>701 to 800</u>	<u>10</u>
<u>801 to 900</u>	<u>11</u>
<u>901 to 1000</u>	<u>12</u>
<u>1001 and over</u>	<u>12, plus 1 for every 100, or fraction thereof, over 1000</u>

1110.6.8.2 Dispersion. Accessible boat slips shall be dispersed throughout the various types of boat slips provided. Where the minimum number of accessible boat slips 1 has been met, no further dispersion shall be required.

1110.6.8.3 Boarding Piers at Boat Launch Ramps. Where boarding piers are provided at boat launch ramps, at least 5 percent, but no fewer than one, of the boarding piers shall comply with ICC A117.1.

1110.6.9 Exercise Machines and Equipment. At least one of each type of exercise machines and equipment shall comply with ICC A117.1 and shall be on an accessible route.

1110.6.10 Fishing Piers and Platforms. Fishing piers and platforms shall comply with ICC A117.1 and be on an accessible route.

1110.6.11 Golf Facilities. Golf facilities shall comply with 1110.6.11.1 through 1110.6.11.3.

1110.6.11.1 Golf Courses. Golf courses shall comply with 1110.6.11.1.1 through 1110.6.11.1.3.

1110.6.11.1.1 Teeing Grounds. Where one teeing ground is provided for a hole, the teeing ground shall be designed and constructed so that a golf car can enter and exit the teeing ground. Where two teeing grounds are provided for a hole, the forward teeing ground shall be designed and constructed so that a golf car can enter and exit the teeing ground. Where three or more teeing grounds are provided for a hole, at least two teeing grounds, including the forward teeing ground, shall be designed and constructed so that a golf car can enter and exit each teeing ground.

1110.6.11.1.2 Putting Greens. Putting greens shall be designed and constructed so that a golf car can enter and exit the putting green.

1110.6.11.1.3 Weather Shelters. Where provided, weather shelters shall be designed and constructed so that a golf car can enter and exit the weather shelter and shall comply with ICC A117.1.

1110.6.11.2 Practice Putting Greens, Practice Teeing Grounds, and Teeing Stations at Driving Ranges. At least 5 percent, but no fewer than one, of practice putting greens, practice teeing grounds, and teeing stations at driving ranges shall be designed and constructed so that a golf car can enter and exit the practice putting greens, practice teeing grounds, and teeing stations at driving ranges.

1110.6.11.3 Golf Facilities. At least one accessible route shall connect accessible elements and spaces within the boundary of the golf course. In addition, accessible routes serving golf car rental areas; bag drop areas; course

weather shelters; course toilet rooms; and practice putting greens, practice teeing grounds, and teeing stations at driving ranges complying with Section 1110.6.11.2 shall comply with ICC A117.1.

Exception: Golf car passages complying with ICC A117.1 shall be permitted to be used for all or part of accessible routes required by this section.

1110.6.12 Miniature golf facilities. Miniature golf facilities shall comply with 1110.6.12.1 through 1110.6.12.3.

1110.6.12.1 Minimum Number. At least 50 percent of holes on miniature golf courses shall comply with ICC A117.1.

1110.6.12.2 Miniature Golf Course Configuration. Miniature golf courses shall be configured so that the holes complying with ICC A117.1 are consecutive. Miniature golf courses shall provide an accessible route from the last hole complying with ICC A117.1 to the course entrance or exit without requiring travel through any other holes on the course.

Exception: One break in the sequence of consecutive holes shall be permitted provided that the last hole on the miniature golf course is the last hole in the sequence.

1110.6.12.3 Miniature Golf Facilities. Holes required to comply with 1110.6.12.1, including the start of play, shall be on an accessible route.

1110.6.13 Play Areas. Play areas shall comply with ICC A117.1.

1110.6.14 Shooting Facilities with Firing Positions. Where shooting facilities with firing positions are designed and constructed at a site, at least 5 percent, but no fewer than one, of each type of firing position shall comply with ICC A117.1.

1110.6.15 Animal Containment Areas. Animal containment areas that are not for public use are not required to be accessible or to be on an accessible route.

3411.8 (IEBC 310.8) Scoping for alterations. The provisions of Sections 3411.8.1 through ~~3411.8.14~~ 3411.8.16 shall apply to *alterations* to existing buildings and facilities.

3411.8.15 (IEBC 310.8.15) Existing Amusement Rides. Where existing amusement rides are altered, the alteration shall comply with Section 3411.8.15.1 and 3411.8.15.2.

3411.8.15.1 (IEBC 310.8.15.1) Load and Unload Areas. Where load and unload areas serving existing amusement rides are newly designed and constructed, the load and unload areas shall comply with ICC A117.1.

3411.8.15.2 (IEBC 310.8.15.2) Minimum Number. Where the structural or operational characteristics of an amusement ride are altered to the extent that the amusement ride's performance differs from that specified by the manufacturer or the original design, the amusement ride shall comply with requirements for new construction in Section 1110.6.7.

3411.8.16 (IEBC 310.8) Teeing Grounds. When golf courses are being altered, teeing grounds shall comply with Section 1110.6.11.1.1.

Exception: In existing golf courses, the forward teeing ground shall not be required to be one of the teeing grounds on a hole designed and constructed so that a golf car can enter and exit the teeing ground where compliance is not feasible due to terrain.

PART II – IEBC

605.1 General. A building, facility or element that is altered shall comply with the applicable provisions in Sections 605.1.1 through ~~605.1.14~~ 605.2.16, Chapter 11 of the *International Building Code* and ICC A117.1 unless it is *technically infeasible*. Where compliance with this section is *technically infeasible*, the *alteration* shall provide access to the maximum extent that is technically feasible.

A building, facility or element that is constructed or altered to be accessible shall be maintained accessible during occupancy.

Exceptions:

1. The altered element or space is not required to be on an accessible route unless required by Section 605.2.
2. Accessible means of egress required by Chapter 10 of the *International Building Code* are not required to be provided in existing buildings and facilities.
3. Type B dwelling or sleeping units required by Section 1107 of the *International Building Code* are not required to be provided in existing buildings and facilities.
4. The *alteration* to Type A individually owned dwelling units within a Group R-2 occupancy shall meet the provisions for Type B dwelling units and shall comply with the applicable provisions in Chapter 11 of the *International Building Code* and ICC A117.1.

605.1.15 Existing Amusement Rides. Where existing amusement rides are altered, the alteration shall comply with Section 605.1.15.1 and 605.1.15.2.

605.1.15.1 Load and Unload Areas. Where load and unload areas serving existing amusement rides are newly designed and constructed, the load and unload areas shall comply with ICC A117.1.

605.1.15.2 Minimum Number. Where the structural or operational characteristics of an amusement ride are altered to the extent that the amusement ride's performance differs from that specified by the manufacturer or the original design, the amusement ride shall comply with requirements for new construction in Section 1110.6.7.

605.1.16 Teeing Grounds. When golf courses are being altered, teeing grounds shall comply with Section 1110.6.11.1.1.

Exception: In existing golf courses, the forward teeing ground shall not be required to be one of the teeing grounds on a hole designed and constructed so that a golf car can enter and exit the teeing ground where compliance is not feasible due to terrain.

Reason: ICC A117.1-2009 will include a new Chapter 11 which contains accessibility requirements for recreational facilities including: amusement rides, recreational boating and fishing facilities, exercise machines and equipment, golf and miniature golf facilities, play areas, swimming and wading pools and shooting facilities. The new requirements in ICC A117.1 and in this proposal are drawn directly from the U.S. Access Board's Americans with Disabilities Act (ADA) Accessibility Guidelines for Recreation Facilities originally published in the *Federal Register* on September 3, 2002. These guidelines and the previously issued guidelines for Play Areas (October 2000) were both later incorporated into the Access Board's 2004 ADA and Architectural Barriers Act (ABA) Accessibility Guidelines. Together with new Chapter 11 of the ICC A117.1, the proposal is consistent with the aforementioned Federal guidelines and will afford adults and children with disabilities a reasonable level of access to recreation and play.

Amusement Rides: This proposal addresses access to amusement rides for persons with disabilities, including those who use wheelchairs. Specifications require provision of either a wheelchair space on the ride or a ride seat or device designed for transfer to the ride. Access at loading and unloading areas is also addressed. Specific criteria for wheelchair spaces, ride seats designed for transfer, and transfer devices is included in ICC ANSI A117.1. Certain exceptions are provided in proposed IBC Sections 1110.6.7 for rides that are: set up temporarily, such as at a traveling carnival, designed primarily for children, controlled or operated by the rider, or not equipped with seats.

Boating Facilities: Boating facilities, such as piers and docks provided at marinas to serve recreational vessels, are covered by this proposal which addresses the minimum number of accessible boat slips required to be accessible. This number is based on a table according to the total amount of boat slips provided at a facility. The dynamic interface between land and water presents unique and significant challenges in providing access to floating facilities. Therefore, new Chapter 11 in ICC ANSI A117.1 – 2009 for gangways connecting floating facilities take these constraints into account by modifying requirements for accessible routes and ramps with exceptions to criteria for maximum rise and slope, handrail extensions, and level landings.

Fishing Piers and Platforms: ICC ANSI A117.1 contains new provisions addressing railings and edge protection located on fishing piers and platforms. Railings, guardrails, and handrails are not required by this accessibility standard. However, where they are provided, a portion (at least 25%) cannot be more than 34 inches high so that the railings do not obstruct fishing for people using wheelchairs. An exception permits the use of a guard complying with the International Building Code where required or voluntarily provided. Edge protection at least 2 inches high is also addressed to prevent the wheels of mobility aids from slipping over the edge.

Golf: Access to golf courses is typically achieved through the use of golf cars. An exception to proposed 1110.6.11.3 permits golf car passages in lieu of accessible routes throughout golf courses. To comply, courses must be designed so that golf cars can access teeing grounds and putting greens. Modified accessible routes are required to serve practice putting greens and driving ranges since they often are not located within the boundary of a course. Technical specifications are provided for golf car passages, accessible routes, teeing grounds, putting greens, and weather shelters in ICC ANSI A117.1.

Miniature Golf: At least half of the holes on a miniature golf course must be served by an accessible route. Specifications for accessible routes take into account design conventions for miniature golf courses, such as carpeted surfaces and curbs. All level areas of an accessible hole where a ball may come to rest must be within the reach of golf clubs (36 inches) from accessible routes.

Play Areas: Requirements in ICC A117.1 comprise a subsection of the new chapter on recreation facilities. They cover the number of play components required to be accessible, accessible surfacing in play areas, ramp access and transfer system access to elevated structures, and access to soft contained play structures. The guidelines address play areas typically provided at schools, parks, child care facilities (except those based in the operator's home, which are exempted by ICC ANSI A117.1 Section 1108), and other facilities.

Exercise Equipment and Machines, Bowling Lanes, and Shooting Facilities: Provisions for exercise equipment, bowling lanes, and shooting facilities are addressed in this proposal. The accessibility standards do not affect the design of exercise equipment and machines, but instead require one of each type to be on an accessible route and to provide transfer space for persons using wheelchairs. Access is also required to a portion (at least 5%) of bowling lanes and shooting facilities.

Swimming Pools and Wading Pools: Specifications are provided for various means of providing pool access, including pool lifts, sloped entries, transfer walls, transfer systems, and stairs. Access to swimming pools can be achieved by sloped entries or pool lifts. For larger pools (those with 300 or more linear feet of pool wall), a secondary means of access is proposed. Stairs, transfer systems, or transfer walls can be used instead of lifts or sloped entries for this secondary means of access. This is a reasonable provision in light of the fact that nationally recognized safety standards require two means of exit from such larger swimming pools. Specific provisions are also provided for wading pools, wave action pools and other types of pools where user access is limited to one area.

Cost Impact: This code change will increase the cost of construction. However, because these changes are harmonized with the U.S. Access Board's ADA and ABA Accessibility Guidelines, costs associated with compliance cannot be avoided once the U.S. Department of Justice adopts the guidelines as enforceable standards under the Americans with Disabilities Act. The guidelines have already been adopted as enforceable standards under the Architectural Barriers Act applicable to federally funded facilities.

PART I – IBC MEANS OF EGRESS

Public Hearing:	Committee:	AS	AM	D
	Assembly:	ASF	AMF	DF

PART II – IEBC

Public Hearing:	Committee:	AS	AM	D
	Assembly:	ASF	AMF	DF

ICCFILENAME:Mazz-E2-1102.1

E153–09/10

1102.1

Proponent: Donald E. Irwin, Program Manager, Delivery, Collection & Carrier Equipment, representing United States Postal Service

Revise as follows:

1102.1 Definitions. The following words and terms shall, for the purposes of this chapter and as used elsewhere in the code, have the meanings shown herein:

COMMON USE: Interior or exterior circulation paths, rooms, spaces or elements that are not for public use and are made available for the shared use of either two or more people in a non-residential facility or the residents of two or more units of a residential facility.

Reason: In support of the effort to clarify what the accessibility requirements are for the individual mail delivery compartments of a centralized mailbox, for residential facilities, the current IBC definition of "common use" is inadequate. The definition needs to be expanded in order to relate to the residents of a building (a "covered multi-family dwelling") or residential complex. There are many "common use" examples of what residents of multiple residential dwelling units do share (for instance, a building's trash receptacle, a common entranceway into the building or to ground-level apartments, or a laundry room (including certain items in the room)). Individual mail delivery compartments of a ganged or centralized mailbox, however, are not shared or "common use" for the residents of multiple residential units. They are designed for assignment to residents of only one street address at a time (although the particular mail compartment assigned to an address can subsequently be changed when required (for instance, if there is a reach issue (an assigned compartment is found to be either too low or too high for the current resident).)

The route to the mail room itself is shared amongst the residents of two or more residential units, the mail room (the floor space in front of the mailbox) is shared amongst these residents, even the parcel lockers that might be integral to any centralized mailbox are shared, but the individual mail delivery compartments are not shared amongst the residents of two or more residential units and, therefore, are not "common use" items. The current definition does not allow for this clarification to be understood properly.

From the Department of Justice website, an analysis of how the term "common use" is applicable to a residential (apartment) complex is available in a 2004 court opinion from the United States Court of Appeals for the Sixth Circuit, USA v. Edward Rose & Sons, et al (2004 FED App. 0279P (6th Cir.). (See the "III. Analysis" section content regarding "the two apartments share".)

http://www.usdoj.gov/crt/housing/documents/rose_opin_landing.php

Cost Impact: The code change proposal will not increase the cost of construction.

Public Hearing:	Committee:	AS	AM	D
	Assembly:	ASF	AMF	DF

ICCFILENAME:Irwin-G2-1102.1

E154–09/10

1102.1

Proponent: Janet Reed, Architect, City of Phoenix – Development Services Department

Revise definition follows:

1102.1 Definitions. The following words and terms shall, for the purposes of this chapter and as used elsewhere in the code, have the meanings shown herein:

MULTISTORY UNIT. A dwelling unit or sleeping unit with habitable space located on more than one story or above a private garage.

Reason: This amendment is to make the code consistent with Fair Housing Act requirements. Frank Keating, General Counsel for HUD, issued a memo dated 12/16/1991 that exempts carriage house unit designs. These units are stacked housing units designed to incorporate parking for each unit into the dwelling unit design in non-elevator buildings where the garage footprint is used as the footprint for the remaining floor or floors of the unit. See 1.29 of the Fair Housing Act Design Manual.

Cost Impact: The code change proposal will not increase the cost of construction.

Public Hearing: Committee:	AS	AM	D
Assembly:	ASF	AMF	DF

ICCFILENAME: ReedJ-E2-1102.1

E155–09/10

1102.1

Proponent: Gilles J. Malkine, Action Toward Independence, Inc.

Add new definition as follows:

1102.1 Definitions. The following words and terms shall, for the purposes of this chapter and as used elsewhere in the code, have the meanings shown herein:

OFFICE OF A HEALTH CARE PROVIDER. A location where a person or entity regulated by a state to provide professional services related to the physical or mental health of an individual makes such services available to the public.

Reason: Add new text (as follows) as definition of "health care provider" as defined by the Americans with Disabilities Act standards, Subpart D, section 36:401 (d)(i):

Adopting this ADA definition will ensure that the scope of covered entities under the IBC (e.g., 1104.4 Exp. 1) will be equal in breadth to that of the ADA. It will help in maximizing the types of agencies obliged to provide accessibility to the public if they provide "professional services related to" health care, as may be determined on a case-by-case basis. It will empower code officials to consider their interpretation of the term 'health care provider' in the largest possible context, as opposed to using other, more restrictive and less stringent definitions that exclude all but 'licensed' or 'medical' entities from the obligation to provide accessibility.

The result will be superior to the current IBC as it will prevent code officials, in the absence of any definition, from construing a narrow and constricted view of what services are health care-related.

In support of this view, the US Code recognizes that entities other than licensed medical providers may be authorized (by contract for example) to provide health care services: **Title 42 USC - Sec. 11151. Definitions** (6) The terms "licensed health care practitioner" and "practitioner" mean, with respect to a State, an individual (other than a physician) who is licensed or otherwise authorized by the State to provide health care services.

Example: an ADA Title III privately owned professional non-profit counseling agency that provides its services publicly to AIDS patients through a state Department of Health contract and that is obliged by that contract to abide by specified state DOH regulations would qualify as a health care provider, and as such would be required to comply with applicable Title III accessibility provisions.

Bibliography:

Americans with Disabilities Act of 1990 – section 36.401
US Code Title 42 The Public Health and Welfare

Cost Impact: The code change proposal will not increase the cost of construction.

Public Hearing: Committee:	AS	AM	D
Assembly:	ASF	AMF	DF

ICCFILENAME:malkine-G1-202

E156–09/10

1102.1, 1107.2, 1107.6, 1107.6.2.2, 1107.6.3, 3411.1 (IEBC 310.1); IEBC 605.1; IRC R202, R320.2 (New)

Proponent: Mark J. Mazz, AIA, representing self

THIS IS A 3 PART CODE CHANGE. PARTS I AND II WILL BE HEARD BY THE IBC MEANS OF EGRESS COMMITTEE. PART III WILL BE HEARD BY THE IRC BUILDING/ENERGY COMMITTEE. SEE THE TENTATIVE HEARING ORDERS FOR THESE COMMITTEES.

PART I – IBC MEANS OF EGRESS

1. Add new definitions as follows:

1102.1 Definitions. The following words and terms shall, for the purposes of this chapter and as used elsewhere in this code, have the meanings shown herein.

PUBLIC RIGHT OF WAY. Public land or property, usually in interconnected corridors, that is acquired for or devoted to transportation purposes.

TYPE C (Visitable) UNIT. A dwelling unit designed and constructed for accessibility in accordance with this code and the provisions for Type C units in ICC A117.1.

2. Revise as follows:

1107.2 Design. Dwelling units and sleeping units that are required to be Accessible units, Type A units, and Type B units, and Type C units shall comply with the applicable portions of Chapter 10 of ICC A117.1. Units required to be Type A units are permitted to be designed and constructed as Accessible units. Units required to be Type B units are permitted to be designed and constructed as Accessible units or as Type A units. Units required to be Type C (Visitable) units are permitted to be designed and constructed as Accessible units, as Type A units, or as Type B units.

1107.6 Group R. Accessible units, Type A units, and Type B Units, and Type C (Visitable) units shall be provided in Group R occupancies in accordance with Sections 1107.6.1 through 1107.6.4.

1107.6.2.2 Group R-2 other than apartment houses, monasteries and convents. In Group R-2 occupancies, other than apartment houses, monasteries and convents, Accessible units, and Type B units, and Type C units shall be provided in accordance with Sections 1107.6.2.2.1 through ~~1107.6.2.2.2~~ 1107.6.2.2.3.

1107.6.2.2.3 Type C units. Where there are 6 or more dwelling units in a development site, at least 50 percent shall be a Type C unit. All R-2 units on a development site shall be considered to determine the total number of units and the required number of Type C units.

Exceptions: The following units are not required to be Type C units or be considered to determine the total number of units:

1. Units above other units.
2. Units without garages where the slope between the finish ground level at all unit entrances to all points along the property lines that border a public right of way are no greater than 8.33 percent.

1107.6.3 Group R-3. Type B units and Type C units shall be provided in Group R-3 occupancies in accordance with Sections 1107.6.3.1 and 1107.6.3.2.

1107.6.3.1 Type B units. In Group R-3 occupancies where there are four or more dwelling units intended to be occupied as a residence in a single structure, every dwelling unit intended to be occupied as a residence shall be a Type B unit.

Exception: The number of Type B units is permitted to be reduced in accordance with Section 1107.7.

1107.6.3.2 Type C units. In Group R-3 occupancies, where there are 6 or more dwelling units in a development site, at least 50 percent shall be a Type C unit. All R-3 units on a development site shall be considered to determine the total number of units and the required number of Type C units.

Exceptions: The following units are not required to be Type C units or be considered to determine the total number of units

1. Units above other units.
2. Units without garages where the slope between the finish ground level at all unit entrances to all points along the property lines that border a public right of way are no greater than 8.33 percent.

1107.7.5 Design flood elevation. The required number of Type A units, Type B units, and Type C units shall not apply to a site in accordance with 1107.7.5.1 through 1107.7.5.2.

1107.7.5.1 Type A units and Type B units. The required number of Type A units and Type B units shall not apply to a site where the required elevation of the lowest floor or the lowest horizontal structural building members of nonelevator buildings are at or above the design flood elevation resulting in:

1. A difference in elevation between the minimum required floor elevation at the primary entrances and vehicular and pedestrian arrival points within 50 feet (15 240 mm) exceeding 30 inches (762 mm), and
2. A slope exceeding 10 percent between the minimum required floor elevation at the primary entrances and vehicular and pedestrian arrival points within 50 feet (15.24 m).

Where no such arrival points are within 50 feet (15.24 m) of the primary entrances, the closest arrival points shall be used.

1107.7.5.2 Type C units. The required number of Type C dwelling units shall not apply to a site where the required elevation of the lowest floor or the lowest horizontal structural building members are at or above the design flood elevation resulting in:

1. A difference in elevation between the minimum required floor elevation at all unit entrances and the ground elevation at the entrance exceeds 30 inches (762 mm), or
2. A slope exceeding 8.33 percent between the minimum required floor elevation at all unit entrances to all points along the property lines that border a public right of way.

3411.1 (IEBC 310.1) Scope. The provisions of Sections 3411.1 through 3411.9 apply to maintenance, change of occupancy, additions and alterations to existing buildings, including those identified as historic buildings.

Exceptions:

1. Type B dwelling or sleeping units required by Section 1107 of this code are not required to be provided in existing buildings and facilities being altered or undergoing a change of occupancy.
2. Type C dwelling required by Section 1107 of this code are not required to be provided in additions or in existing buildings and facilities being altered or undergoing a change of occupancy.

(Renumber subsequent sections)

PART II - IEBC

Revise as follows:

605.1 General. A building, facility or element that is altered shall comply with the applicable provisions in Sections 605.1.1 through 605.1.14, Chapter 11 of the International Building Code and ICC A117.1 unless it is technically infeasible. Where compliance with this section is technically infeasible, the alteration shall provide access to the maximum extent that is technically feasible.

A building, facility or element that is constructed or altered to be accessible shall be maintained accessible during occupancy.

Exceptions:

1. The altered element or space is not required to be on an accessible route unless required by Section 605.2.
2. Accessible means of egress required by Chapter 10 of the International Building Code are not required to be provided in existing buildings and facilities.
3. Type B dwelling or sleeping units required by Section 1107 of the International Building Code are not required to be provided in existing buildings and facilities.
4. The alteration to Type A individually owned dwelling units within a Group R-2 occupancy shall meet the provisions for Type B dwelling units and shall comply with the applicable provisions in Chapter 11 of the International Building Code and ICC A117.1.
5. Type C dwelling required by Section 1107 of the International Building Code are not required to be provided in additions or in existing buildings and facilities being altered or undergoing a change of occupancy.

PART III – IRC BUILDING/ENERGY

Add new text as follows:

SECTION R202 DEFINITIONS

PUBLIC RIGHT OF WAY. Public land or property, usually in interconnected corridors, that is acquired for or devoted to transportation purposes.

TYPE C (Visitable) UNIT. A dwelling unit designed and constructed for accessibility in accordance with this code and the provisions for Type C units in ICC A117.1.

R320.2 Visitable (Type C) units. Where there are 6 or more dwelling in a development site, at least 50 percent shall be a Type C unit. All units on a development site shall be considered to determine the total number of units and the required number of Type C units.

Exceptions:

1. Type C units shall be permitted to be designed and constructed as Accessible units, Type A units, or Type B units in accordance with Chapter 11 of the International Building Code.
2. The following units are not required to meet Type C unit requirements or be considered to determine the total number of units:
 - 2.1 Units above other units.
 - 2.2 Units without garages where the slope between the finish ground level at all unit entrances to all points along the property lines that border a public right of way are no greater than 8.33 percent.
3. Type C dwelling are not required to be provided in additions or in existing buildings and facilities being altered or undergoing a change of occupancy.
4. The required number of Type C units shall not apply to a site where the required elevation of the lowest floor or the lowest horizontal structural building members are at or above the design flood elevation resulting in:
 - 4.1 A difference in elevation between the minimum required floor elevation at all unit entrances and the ground elevation at the entrance exceeds 30 inches (762 mm), or
 - 4.2 A slope exceeding 8.33 percent between the minimum required floor elevation at all unit entrances to all points along the property lines that border a public right of way.

Reason: Type C dwelling units have been added to the technical requirements in 2009 ICC/A117.1. The intent of this proposal is to scope Type C dwelling units for buildings that fall below the threshold of the Fair Housing Act Accessibility Guidelines.

1. There is a correlative change being proposed for the IBC, IRC and IEBC.
2. Type C (Visitable) units require significantly less accessibility than Type B units do. Type C units require one zero-step entrance on a circulation path (not necessarily an accessible route) from a garage, driveway, sidewalk, or street. The entrance does not have to be the front door. Therefore, an attached garage, with a floor that slopes away from a connecting door that has no step can satisfy the zero-step entrance requirement. Interior requirements for Type C units apply only to the entry level and are equally as lax as the exterior requirements.

3. Jurisdictions across the Country are adding Visitability requirements to their local codes. Neither the technical provisions nor the scoping provisions are consistent. To address the technical provisions, ICC A117.1 created Type C (Visitable) units. This proposed change to the Building Code is to make the scoping provisions consistent.
4. Because of site constraints, individual dwelling units, in-fill units, and small developments may have difficulty with providing a zero-step entrance. Therefore, this proposal limits applicability to developments with 6 or more dwelling units.
5. Other site issues, such as trees, preserving natural terrain, and local design guidelines, when coupled with zero-step entrances may increase construction costs by more than a few hundred dollars. In lieu of listing a series of exceptions, this proposal applies to only half the R-2 and R-3 dwelling units.
6. The technical requirements for Type C units are a subset of the Accessible, Type A, and Type B unit technical requirements. Therefore, requiring those units to comply with Type C units is redundant.
7. Stacked townhomes are becoming popular. The proposal only addresses the units nearest the ground. Upper unit is exempted from compliance. Lower units are exempted when the entrance level is significantly below ground.
8. Providing a zero-step entrance is more expensive on a small lot where the unit does not have a garage, particularly on sites with steeper slopes. Therefore, this proposal exempts units where the difference in grade elevation at all the entrances and the elevation along property lines that are along the public right of way slopes more than 8.33%.
9. Modifying existing structures will cost, on average, more than a few hundred dollars. Therefore, existing structures and additions are exempted.

Cost Impact: \$100 to \$400 per dwelling unit. See "Increasing Home Access: Designing for Visitability" by the AARP Public Policy Institute. http://assets.aarp.org/rgcenter/il/2008_14_access.pdf

PART I – IBC MEANS OF EGRESS

Public Hearing:	Committee:	AS	AM	D
	Assembly:	ASF	AMF	DF

PART II – IEBC

Public Hearing:	Committee:	AS	AM	D
	Assembly:	ASF	AMF	DF

PART III – IRC BUILDING/ENERGY

Public Hearing:	Committee:	AS	AM	D
	Assembly:	ASF	AMF	DF

ICCFILENAME:Mazz Mark-E1-1102.1

E157–09/10

1103.2.3

Proponent: Curt Wiehle, Minnesota Construction Codes and Licensing Division, representing CCLD

Revise as follows:

1103.2.3 Employee work areas. Spaces and elements within employee work areas shall only be required to comply with Sections 907.9.1.2, 1007 and 1104.3.1 and shall be designed and constructed so that individuals with disabilities can approach, enter and exit the work area. Work areas, or portions of work areas, that are less than 300 square feet (30 m²) in area and ~~elevated~~ located 7 inches (178 mm) or more above or below the ground or finish floor where the change in elevation is essential to the function of the space shall be exempt from all requirements.

Reason: There is no reason to limit the elevation change to raised areas. Employee work areas may also need be lowered in order to function - as in an automotive service pit.

Cost Impact: The code change proposal will not increase the cost of construction.

Public Hearing:	Committee:	AS	AM	D
	Assembly:	ASF	AMF	DF

ICCFILENAME:Wiehle-E9-1103.2.3

E158–09/10

1103.2.7, 1103.2.8 (New)

Proponent: Ron Clements, Chesterfield County Virginia Building Inspection Department, representing self

1. Revise as follows:

1103.2.7 Raised areas, safety and security. Raised areas used primarily purposes of security, life safety or fire safety including, but not limited to, observation galleries, prison guard towers, fire towers or lifeguard stands, are not required to be accessible or be served by an accessible route.

2. Add new text as follows:

1103.2.8 Raised and recessed areas in places of religious worship. Raised and recessed areas used primarily for religious ceremonies in a place of religious worship are not required to be accessible or be served by an accessible route.

(Renumber remaining sections)

Reason: The current accessibility provisions of chapter 11 in the IBC and the ICC/ANSI A117.1 standard were developed from the Americans With Disabilities act and in large part by people involved in the ADA. The Americans with Disabilities act section 307 exempts religious organizations and religions buildings from compliance with the act. Due to this exemption accessibility to specific church architectural elements has never been developed and is not addressed in the code or A117.1standard. Providing access routes to elevated areas such as Altars, bimahs, baptisteries, pulpits, platforms and other elevated areas within churches used for the performance of church religious services is very difficult and costly. Furthermore even if an accessible route is provided to these areas there is no guidance to make a religious feature such as a baptistery accessible. Since there is already an accessibility exemption for raised areas used for safety and security this proposal adds "safety and security" to the existing raised area exemption and adds this new exemption directly following the existing raised area exemption. Recessed areas is also addressed do to the use of recessed areas for religious ceremonies and rites by certain religions.

Cost Impact: This will reduce the cost of constructing religious buildings.

Public Hearing:	Committee:	AS	AM	D
	Assembly:	ASF	AMF	DF

ICCFILENAME:Clements-E2-1103.2

E159–09/10

1103.2.12

Proponent: Curt Wiehle, Minnesota Construction Codes and Licensing Division, representing CCLD

Delete without substitution:

~~**1103.2.12 Day care facilities.** Where a day care facility (Groups A-3, E, I-4 and R-3) is part of a dwelling unit, only the portion of the structure utilized for the day care facility is required to be accessible.~~

Reason: A business operated in a dwelling is covered in Sections 1103.2.13 and 419 Live/Work Units. Section 1103.2.12 is duplicative and potentially conflicting.

Cost Impact: The code change proposal will not increase the cost of construction.

Public Hearing:	Committee:	AS	AM	D
	Assembly:	ASF	AMF	DF

ICCFILENAME:Wiehle-E10-1103.2.12

E160–09/10

1007.5, 1103.2.13, 1109.7 (IFC [B] 1007.5)

Proponent: Curt Wiehle, Minnesota Construction Codes and Licensing Division, representing CCLD

Revise as follows:

~~1103.2.13~~ **1109.15 Live/Work units.** In Live/Work units constructed in accordance with Section 419, the portion of the unit utilized for nonresidential use is required to be accessible. The residential portion of the Live/Work unit is required to be evaluated separately in accordance with Sections 1107.6.2 and 1107.7.

1109.7 Lifts. Platform (wheelchair) lifts are permitted to be a part of a required accessible route in new construction where indicated in Items 1 through 40 11. Platform (wheelchair) lifts shall be installed in accordance with ASME A18.1.

1. An accessible route to a performing area and speaker platforms in Group A occupancies.
2. An accessible route to wheelchair spaces required to comply with the wheelchair space dispersion requirements of Sections 1108.2.2 through 1108.2.6.
3. An accessible route to spaces that are not open to the general public with an occupant load of not more than five.
4. An accessible route within a dwelling or sleeping unit.
5. An accessible route to wheelchair seating spaces located in outdoor dining terraces in Group A-5 occupancies where the means of egress from the dining terraces to a public way are open to the outdoors.
6. An accessible route to jury boxes and witness stands; raised courtroom stations including judges' benches, clerks' stations, bailiffs' stations, deputy clerks' stations and court reporters' stations; and to depressed areas such as the well of the court.
7. An accessible route to load and unload areas serving amusement rides.
8. An accessible route to play components or soft contained play structures.
9. An accessible route to team or player seating areas serving areas of sport activity.
10. An accessible route to or within a live/work unit.
- ~~40.11.~~ An accessible route where existing exterior site constraints make use of a ramp or elevator infeasible.

1007.5 (IFC [B] 1007.5) Platform lifts. Platform (wheelchair) lifts shall not serve as part of an accessible means of egress, except where allowed as part of a required accessible route in Section 1109.7, Items 1 through 9 10. Standby power shall be provided in accordance with Chapter 27 for platform lifts permitted to serve as part of a means of egress.

Reason: Live/work units should not be located in Section 1103 as this section is for exceptions only. This provision is applying accessibility to the work portion of the dwelling and possibly the dwelling unit and should therefore be located in the Other Facilities section. Allowing a platform lift to be used for the required accessible route in a live/work unit is reasonable due to the probable low occupant factor and the potential difficulty in providing a ramp. Given the limited occupants, it should also be permitted as part of an accessible means of egress.

Cost Impact: The code change proposal will not increase the cost of construction.

Public Hearing: Committee:	AS	AM	D
Assembly:	ASF	AMF	DF

ICCFILENAME:Wiehle-E11-1103.2.13

E161–09/10

1103.2.16 (New), 1109.13

Proponent: Curt Wiehle, Minnesota Construction Codes and Licensing Division, representing CCLD

1. Add new text as follows:

1103.2.16 Appliance controls. Operating mechanisms and controls on appliances such as ATM machines, vending machines, ovens, microwave ovens, cooktops, washers and dryers are not required to be accessible.

2. Delete without substitution:

~~**1109.13 Fuel-dispensing systems.** Fuel-dispensing systems shall comply with ICC A117.1.~~

Reason: The application of the building code to appliances should be limited to the provision of an accessible route and clear floor space. Controls on the appliance itself should not be regulated by the building code. Civil rights laws provide a better means of addressing these issues.

Cost Impact: The code change proposal will not increase the cost of construction.

Public Hearing: Committee: AS AM D
Assembly: ASF AMF DF

ICCFILENAME:Wiehle-E12-1103.2.16

E162-09/10

1104.3.1

Proponent: Curt Wiehle, Minnesota Construction Codes and Licensing Division, representing CCLD

Revise as follows:

1104.3.1 Employee work areas. Common use circulation paths within employee work areas shall be accessible routes.

Exceptions:

1. Common use circulation paths, located within employee work areas that are less than ~~300~~ 1,000 square feet (~~27.9~~ 93 m²) in size and defined by permanently installed partitions, counters, casework or furnishings, shall not be required to be accessible routes.
2. Common use circulation paths, located within employee work areas, that are an integral component of equipment, shall not be required to be accessible routes.
3. Common use circulation paths, located within exterior employee work areas that are fully exposed to the weather, shall not be required to be accessible routes.

Reason: To align with the federal Americans with Disabilities Act Accessibility Guidelines.

Cost Impact: The code change proposal will not increase the cost of construction.

Public Hearing: Committee: AS AM D
Assembly: ASF AMF DF

ICCFILENAME:Wiehle-E13-1104.3.1

E163-09/10

1104.4

Proponent: Curt Wiehle, Minnesota Construction Codes and Licensing Division, representing CCLD

Revise as follows:

1104.4 Multilevel buildings and facilities. At least one accessible route shall connect each ~~accessible~~ level, including mezzanines, in multilevel buildings and facilities.

Exceptions:

1. An accessible route is not required to stories and mezzanines that have an ~~aggregate area occupant load~~ of not more than ~~3,000 square feet (278.7 m²)~~ 30 persons and are located above and below accessible levels. This exception shall not apply to:
 - 1.1. ~~Multiple tenant facilities~~ Public areas of Group M occupancies ~~containing five or more tenant spaces;~~
 - 1.2. ~~Levels containing offices~~ Public areas of health care providers (Group B or I); ~~or~~
 - 1.3. Public areas of Passenger transportation facilities and airports (Group A-3 or B); ~~or~~
 - 1.4. Public areas of municipal and government facilities.
2. Levels that do not contain accessible elements or ~~other~~ spaces as determined by Section 1106, 1107 or 1108 are not required to ~~be served by an accessible route from an accessible level~~ comply with Section 1104.4.
3. In air traffic control towers, an accessible route is not required to serve the cab and the floor immediately below the cab.

4. ~~Where a two-story building or facility has one story with an occupant load of five or fewer persons that does not contain public use space, that story shall not be required to be connected by an accessible route to the story above or below.~~
- 5.4. Vertical access to elevated employee work stations within a courtroom is not required at the time of initial construction, provided a ramp, lift or elevator complying with ICC A117.1 can be installed without requiring reconfiguration or extension of the courtroom or extension of the electrical system.

Reason: Delete accessible from the charging statement as this is the section that defines which levels are required to be accessible. Including accessible in the charging statement is circuitous.

Changes to Exception 1 represent a new approach to determining which stories and mezzanines require an accessible route. The current language appears to be derived from the federal Americans with Disabilities Act guidelines. This approach is inferior to the proposed language as it is based on size of the space. The federal rules do not have a mechanism to determine occupant load and therefore is limited to measuring the size of the space. Building code applies an occupant load based on the use of the space. This is a superior, more logical and consistent method of determining if access to a space is justified. The proposed language establishes a threshold of 30 people maximum where access would not be required. The exceptions to the 30 person occupant load are areas accessed by the general public in certain use groups. All of the "special use groups" are created equal in this proposal including the Group M occupancies. Other than the ADAAG, there is no justification for the current code providing an exception for retail facilities having four or less tenants. The proposed text allows employee work areas within the "special use groups" to have an occupant load of up to 30 employees without providing an accessible route. Exception 4 can be deleted as the issue is sufficiently addressed in Exception 1.

The modification to Exception 2 is to clarify the original intent that spaces or elements addressed in Section 1107 or 1108 are not required to provide an accessible route per Section 1104.4. A new reference to Section 1106 is added for multistory parking structures which will only require an accessible route to the required accessible parking spaces and passenger loading facilities. Levels that do not provide accessible parking spaces will not be required to be provided with an accessible route.

Cost Impact: The code change proposal will increase cost in some situations and reduce cost in others.

Public Hearing: Committee:	AS	AM	D
Assembly:	ASF	AMF	DF

ICCFILENAME:Wiehle-E15-1104.4

E164-09/10

1104.5

Proponent: Curt Wiehle, Minnesota Construction Codes and Licensing Division, representing CCLD

Revise as follows:

1104.5 Location. Accessible routes shall coincide with ~~or be located in the same area as~~ a general circulation path. Where an accessible route diverges from the general circulation path, the accessible route shall be located in the same area as the general circulation path. Where the circulation path is interior, the accessible route shall also be interior. Where only one accessible route is provided, the accessible route shall not pass through kitchens, storage rooms, restrooms, closets or similar spaces.

Exceptions:

1. Accessible routes from parking garages contained within and serving Type B units are not required to be interior.
2. A single accessible route is permitted to pass through a kitchen or storage room in an Accessible unit, Type A unit or Type B unit.

Reason: Providing two criteria in the same sentence, i.e., that routes coincide or be in the same area, gives both alternatives equal value. The intent of the provision should be that the routes coincide to the extent possible and only separate when necessary. Dividing the criteria into two separate sentences achieves this intent.

Cost Impact: The code change proposal will not increase the cost of construction.

Public Hearing: Committee:	AS	AM	D
Assembly:	ASF	AMF	DF

ICCFILENAME:Wiehle-E17-1104.5-2

E165–09/10

1104.5

Proponent: Curt Wiehle, Minnesota Construction Codes and Licensing Division, representing CCLD

Revise as follows:

1104.5 Location. Accessible routes shall coincide with or be located in the same area as a general circulation path. Where the circulation path is interior, the accessible route shall also be interior. Where a circulation path is within a tenant space, the accessible route shall also be within the tenant space. Where only one accessible route is provided, the accessible route shall not pass through kitchens, storage rooms, restrooms, closets or similar spaces.

Exceptions:

1. Accessible routes from parking garages contained within and serving Type B units are not required to be interior.
2. A single accessible route is permitted to pass through a kitchen or storage room in an Accessible unit, Type A unit or Type B unit.

Reason: It is fairly common for retail spaces to have multiple levels. Some retailers in multitenant buildings may have convenience stairs to other floors within the retailer's space but rely on the common use elevator for an accessible route. This requires that customers who are unable to use the stair, leave the store, go to a common use elevator, and reenter the store at the other level. Customers unable to use the stair may have to pay for goods twice if the goods they need are on opposite floors. This is a huge inconvenience for customers unable to use the stair.

Cost Impact: The code change proposal will not increase the cost of construction.

Public Hearing: Committee:	AS	AM	D
Assembly:	ASF	AMF	DF

ICCFILENAME:Wiehle-E16-1104.5

E166–09/10

1106.5

Proponent: Curt Wiehle, Minnesota Construction Codes and Licensing Division, representing CCLD

Revise as follows:

1106.5 Van spaces. For every six or fraction of six accessible parking spaces, at least one shall be a van-accessible parking space.

~~**Exception:** In Group R-2 and R-3 occupancies, van accessible spaces located within private garages shall be permitted to have vehicular routes, entrances, parking spaces, and access aisles with a minimum vertical clearance of 7 feet (2134 mm).~~

Reason: This exception is discriminatory as it does not afford an individual equal treatment at Group R-2 and R-3 facilities. The code recognizes that a vertical clearance exceeding 7 feet is required for van parking at all occupancies other than Groups R-2 and R-3. What happens to the van, which the code acknowledges requires a clearance in excess of 7 feet, such that when it arrives at a Group R occupancy it no longer requires the additional height? The only justification for this exception is that two federal agencies that develop accessible design criteria don't provide the same guidance on this issue (my understanding is that the federal discrepancy is more accidental than deliberate). There is no reason for ICC to incorporate federal conflicts into the building code.

Rather than provide inconsistent and conflicting requirements in the building code based on provisions from various federal agencies, ICC should take the initiative to rectify the discrepancies. Deleting the exception in Section 1106.5 acknowledges the fact that a van does not change based on where it's located and whatever provisions are necessary for the vehicle hold true to all occupancies and facilities. Deleting the exception also does not conflict with federal rule. It simply exceeds a federal rule.

The other action available to ICC is to delete the height requirement altogether – for all occupancies and facilities. The additional height is a costly provision and it could be determined that the cost/benefit is not justified. This would conflict with federal rule but would send a signal to the federal authority suggesting that this issue be reconsidered.

The worst result for the building code is to maintain the current internal conflict that provides different standards for different occupancy groups when there is no justification for the discrepancy based on the subject matter (van height).

Cost Impact: The code change proposal will increase the cost of construction.

Public Hearing: Committee:	AS	AM	D
Assembly:	ASF	AMF	DF

ICCFILENAME:Wiehle-E18-1106.5

E167-09/10

1107.3

Proponent: Karen L. Braitmayer, FAIA, Studio Pacifica, Ltd. representing self

Revise as follows:

1107.3 Accessible spaces. Rooms, ~~and~~ spaces and elements available to the general public or available for use by residents and serving Accessible units, Type A units or Type B units shall be accessible. Accessible spaces shall include toilet and bathing rooms, kitchen, living and dining areas and any exterior spaces, including patios, terraces and balconies. Accessible elements shall include, but not be limited to, mailboxes and trash chutes serving Accessible units, Type A units and Type B units.

Exceptions:

1. Recreational facilities in accordance with Section 1109.14.
2. In Group I-2 facilities, doors to sleeping units shall be exempted from the requirements for maneuvering clearance at the room side provided the door is a minimum of 44 inches (1118 mm) in width.

Reason: Much confusion exists on what elements that are associated with dwelling units must be accessible, and how many. This proposal provides clarity on what build-in elements that directly serve Accessible units, Type A units and Type B units must be accessible, even if they are not contained within the unit itself.

Cost Impact: This code change will not increase the cost of construction.

Public Hearing: Committee:	AS	AM	D
Assembly:	ASF	AMF	DF

ICCFILENAME:Braitmayer-E1-1107.3

E168-09/10

1107.3.1 (New)

Proponent: Edward L. Repic, Architectural Refuse Solutions, LLC, representing self.

Add new text as follows:

1107.3.1 Accessible Rubbish Chute. Rubbish chutes in residential facilities shall be accessible. Rubbish chute intake doors shall comply with ICC A117.1. The combined door and disposal operations shall be capable of being accomplished with a single hand,

Reason: This submittal is part of four such proposals submitted as independent documents with the intent of adequately addressing Rubbish Chutes (which can include "recycling" chutes that simply redirect parts of the rubbish waste stream to locations other than a landfill) and Linen (or Laundry) Chutes. These proposals individually address Life Safety, Sprinkler Placement, Accessibility in new and existing facilities, and actual Chute Construction and a related component to Rubbish Chutes: Compactors (codes generally address the shaft enclosure but ignore the actual chute being enclosed or the compactor it is feeding).

Rubbish chutes, in this case meaning chute intakes, are not required in buildings, but when provided, chutes are typically general access features for use by the public at large ... typically the building end users ... as opposed to features that are solely available to the housekeeping and/or maintenance staff. As such, it is our belief that rubbish chute intake doors are provided as Public-Use Areas in conformance with Section 1102 and should be accessible. By comparison, the rubbish room and its compactor and/or containers ... the disposal facilities for the rubbish chute features on each living levels ... are not designed for public access. Rather, they are the province of the housekeeping and maintenance staff.

The problem lies in the fact that code does not adequately address chute intake doors. It is our purpose to address this particular oversight.

The original 1990 ADA document addressed what it considered "equipment" and their controls. Successive versions, including the ANSI 117.3-2003 document do not address equipment. Rather they address man doors. Their provisions ultimately boil down to the use of lever or tee handles within stipulated reach ranges; a limitation on the force used to open the doors (5lbf or 20N); a prohibition against tight grabbing, pinching or twisting; and finally a requirement for single hand operation.

It is our belief that the rubbish chute intake door should be considered separately from man doors because of their role as opening protectives on a building feature designed for public use. As such, they should be categorized as needing "accessibility" by the ANSI provisions in the previous paragraph and most certainly should meet the single hand operation requirement. Chute industry technology has, for more than a decade, included pneumatically operated intakes that: open with the push of a palm button (large enough to be depressed with *any* available body part); time their opening; and then slowly close themselves.

Compare this with the operation of a non-accessible, standard intake by a disabled person ... let's say an 80 year old woman using a walker and carrying her own garbage. She must get to the door, *release her walker*, grab the intake door handle with one hand, pull it open, hold it open, lift her garbage for disposal, release the door, grab her walker, turn, and walk away. It is not possible for an able bodied person to open a standard intake door and deposit the garbage with one hand. The disabled have no chance.

Cost Impact: ADA compliant, pneumatic intake door: Less than \$1000, installed. Compressor: Approximately \$800, installed. (Please note that the most expensive chute we have ever designed had a value equal to ½ of 1% of the total project cost. Typically the actual range is ¼ to 1/3 of 1%, but even that has limitations, we have seen \$100,000,000 projects with \$30,000 chute installations ... 3/100 of 1%!)

Public Hearing: Committee: AS AM D
Assembly: ASF AMF DF

ICCFILENAME:Repic-E1-1103.1

E169–09/10

1107.5.2.1

Proponent: Curt Wiehle, Minnesota Construction Codes and Licensing Division, representing CCLD

Revise as follows:

1107.5.2 Group I-2 nursing homes. Accessible units and Type B units shall be provided in nursing homes of Group I-2 occupancies in accordance with Sections 1107.5.2.1 and 1107.5.2.2.

1107.5.2.1 Accessible units. At least ~~50~~ 10 percent but not less than one of each type of the dwelling units and sleeping units shall be Accessible units.

1107.5.2.2 Type B units. In structures with four or more dwelling units or sleeping units intended to be occupied as a residence, every dwelling unit and sleeping unit intended to be occupied as a residence shall be a Type B unit.

Exception: The number of Type B units is permitted to be reduced in accordance with Section 1107.7.

Reason: Units designed to the ICC A117.1 standard are intended for unassisted individual use. The overwhelming majority of nursing home residents are incapable of independent use and rely on assistance. The requirement that 50% of the units be designed for independent use is excessive and does not serve the needs of the typical nursing home resident. A common issue in units designed to ICC A117.1 Accessible unit criteria is that the water closet is located next to a side wall making assisted transfers to and from the fixture more difficult. Units not meeting the Accessible unit requirements will be Type B units which can be designed for assisted use.

Cost Impact: The code change proposal will not increase the cost of construction.

Public Hearing: Committee: AS AM D
Assembly: ASF AMF DF

ICCFILENAME:Wiehle-E19-1107.5.2.1

E170–09/10

1107.6.1.1, 1107.6.1.1.1 (New)

Proponent: Curt Wiehle, Minnesota Construction Codes and Licensing Division, representing CCLD

Add new text as follows:

1107.6.1 Group R-1. Accessible units and Type B units shall be provided in Group R-1 occupancies in accordance with Sections 1107.6.1.1 and 1107.6.1.2.

1107.6.1.1 Accessible units. ~~In Group R-1 occupancies,~~ Accessible dwelling units and sleeping units shall be provided in accordance with Table 1107.6.1.1. ~~All R-1 dwelling units and sleeping units on a site shall be considered to determine the total number of Accessible units. Accessible units shall be dispersed among the various classes of units. Roll-in showers provided in Accessible units shall include a permanently mounted folding shower seat.~~

1107.6.1.1.1 Accessible unit facilities. All interior and exterior spaces and elements provided as part of or serving an Accessible dwelling unit or sleeping unit shall be accessible and be located on an accessible route.

Exceptions:

1. Where multiple bathrooms are provided within an Accessible unit, at least one full bathroom shall be accessible.
2. Where multiple family or assisted bathrooms serve an Accessible unit, at least 50% but not less than one room for each use at each cluster shall be accessible.

3. Five percent, but not less than one bed shall be accessible.

1107.6.1.2 Type B units. In structures with four or more dwelling units or sleeping units intended to be occupied as a residence, every dwelling unit and sleeping unit intended to be occupied as a residence shall be a Type B unit.

Exception: The number of Type B units is permitted to be reduced in accordance with Section 1107.7.

Reason: Delete reference to Group R-1 as it is implicit from Section 1107.6.1. The new section is to provide exceptions for Accessible units with multiple bathrooms or multiple beds.

Cost Impact: The code change proposal will not increase the cost of construction.

Public Hearing: Committee:	AS	AM	D
Assembly:	ASF	AMF	DF

ICCFILENAME:Wiehle-E20-1107.6.1.1.1

E171-09/10

1107.6.2.2, 1107.6.2.2.1, 1107.6.2.2.2

Proponent: Curt Wiehle, Minnesota Construction Codes and Licensing Division, representing CCLD

Revise as follows:

1107.6.2.2 Group R-2 other than apartment houses, monasteries and convents. In Group R-2 occupancies, other than apartment houses, monasteries and convents, Accessible units, and Type B units shall be provided in accordance with Sections ~~1107.6.2.2.1 and 1107.6.2.2.2~~ 1107.6.1.1 through 1107.6.1.3.

~~**1107.6.2.2.1 Accessible units.** Accessible dwelling units and sleeping units shall be provided in accordance with Table 1107.6.1.1.~~

~~**1107.6.2.2.2 Type B units.** Where there are four or more dwelling units or sleeping units intended to be occupied as a residence in a single structure, every dwelling unit and every sleeping unit intended to be occupied as a residence shall be a Type B unit.~~

~~**Exception:** The number of Type B units is permitted to be reduced in accordance with Section 1107.7.~~

Reason: To simply the code by deleting duplicative language and to reinforce the concept that these types of units are essentially treated as Group R-1 transient type units.

Note: the reference to Section 1107.6.1.3 is based on approval of a separate proposal to add this new section. If 1107.6.1.3 is not approved, the reference in this proposal should be changed to 1107.6.1.2.

Cost Impact: The code change proposal will not increase the cost of construction.

Public Hearing: Committee:	AS	AM	D
Assembly:	ASF	AMF	DF

ICCFILENAME:Wiehle-E22-1107.6.2.2

E172-09/10

1107.7.2

Proponent: Janet Reed, Architect, representing City of Phoenix – Development Services Department

Revise as follows:

1107.7.2 Multistory units. A multistory dwelling or sleeping unit which is not provided with elevator service is not required to be a Type A or Type B unit. Where a multistory unit is provided with external elevator service to only one floor, the floor provided with elevator service shall be the primary entry to the unit, shall comply with the requirements for a Type B unit and a toilet facility shall be provided on the first floor.

Reason: This amendment is needed to meet the original intentions of ICC. As proposed it complies with Fair Housing Act. Accessibility requirements for townhouses conforming to the requirements of the IRC are referred back to IBC section 1107.6.3 which has requirements for only the Type B units and not Type A. unit. The same requirements should apply to two-story units complying with either the IRC or IBC. It might be noted that this amendment was a code change proposal of Jeff Inks, National Association of Home Builders that was submitted as part of the 2006/2007

code development cycle to ICC. Jeff Inks wrote, "The original primary intent of this general exception is to exclude R 2 multistory dwelling units from the accessibility requirements of this chapter. However when this exception was drafted, focus was on the multistory exceptions included under Fair Housing and inclusion of Type A units were therefore overlooked. The intention of the proposal is to exempt multistory townhouse style dwelling units when they fall into Group R-2 from Type A requirements. This would be consistent with Fair Housing requirements.

Cost Impact: The Code change proposal will not increase the cost of construction.

Public Hearing: Committee:	AS	AM	D
Assembly:	ASF	AMF	DF

ICCFILENAME: ReedJ-E1-1107.7.2

E173-09/10

1107.7.2.1 (New)

Proponent: Dominic Marinelli, representing United Spinal Association

Add new text as follows:

1107.7.2 Multistory units. A multistory dwelling or sleeping unit which is not provided with elevator service is not required to be a Type B unit. Where a multistory unit is provided with external elevator service to only one floor, the floor provided with elevator service shall be the primary entry to the unit, shall comply with the requirements for a Type B unit and a toilet facility shall be provided on that floor.

1107.7.2.1 Dwelling units with private residence elevators. Multistory dwelling units containing a private residence elevator within the dwelling unit shall be a Type B unit. All levels within the dwelling unit shall be served by the elevator and shall comply with the requirements for a Type B unit.

Reason: The current code language in Section 1107.7 is currently NOT clear as to the ramifications of placing a private residence elevator within the interior of a dwelling unit. This change will add that needed clarity.

Cost Impact: The code change proposal will increase the cost of construction

Public Hearing: Committee:	AS	AM	D
Assembly:	ASF	AMF	DF

ICCFILENAME:Marinelli-E1-1108.7.2.1

E174-09/10

1108.2, 1108.2.6

Proponent: Curt Wiehle, Minnesota Construction Codes and Licensing Division, representing CCLD

Revise as follows:

1108.2 Assembly area seating. Assembly areas with fixed seating shall comply with Sections 1108.2.1 through 1108.2.7. ~~Assembly areas without fixed seating shall comply with Sections 1108.2.6 and 1108.2.7. Lawn seating shall comply with Section 1108.2.8.~~ Dining areas shall comply with Section 1108.2.9. ~~In addition, lawn seating shall comply with Section 1108.2.6.~~

1108.2.1 Services. *(No change to current text)*

1108.2.2 Wheelchair spaces. *(No change to current text)*

1108.2.2.1 General seating. *(No change to current text)*

1108.2.2.2 Luxury boxes, club boxes and suites. *(No change to current text)*

1108.2.2.3 Other boxes. *(No change to current text)*

1108.2.2.4 Team or player seating. *(No change to current text)*

1108.2.3 Companion seats. *(No change to current text)*

1108.2.4 Dispersion of wheelchair spaces in multilevel assembly seating areas. (No change to current text)

1108.2.5 Designated aisle seats. (No change to current text)

~~4408.2.7~~ **1108.2.6 Assistive listening systems.** (No change to current text)

~~4408.2.7.1~~ **1108.2.6.1 Receivers.** (No change to current text)

~~4408.2.7.2~~ **1108.2.6.2 Public address system.** (Change reference numbers to 1108.2.6.1 and 1108.2.6.2.2)

~~4408.2.7.2.1~~ **1108.2.6.2.1 Prerecorded text messages.** (No change to current text)

~~4408.2.7.2.2~~ **1108.2.6.2.2 Real-time messages.** (No change to current text)

~~4408.2.8~~ **1108.2.7 Performance areas.** (No change to current text)

~~4408.2.6~~ **1108.2.8 Lawn seating.** Lawn seating areas and exterior overflow seating areas, where fixed seats are not provided, shall connect to an accessible route.

1108.2.9 Dining areas. (No change to current text)

Reason: This proposal applies the performance area accessible route criteria and assistive listening system criteria to assembly areas without fixed seats. This is necessary to comply with the ADA.

Editorially, relocate lawn seating section and renumber accordingly to provide better flow of section.

Cost Impact: The code change proposal will increase the cost of construction.

Public Hearing: Committee:	AS	AM	D
Assembly:	ASF	AMF	DF

ICCFILENAME:Wiehle-E24-1108.2

E175–09/10

1108.2.7.1.2 (New)

Proponent: Dominic Marinelli, representing United Spinal Association

Add new text as follows:

1108.2.7.1.2 Ticket Windows. Where ticket windows are provided in stadiums and arenas at least one of each type shall have an assistive listening system.

Reason: This proposal articulates the advocacy efforts of NY City's Hearing Access Program who worked with the New York Yankees and the New York Mets and Minnesota's Deaf and Hard of Hearing Services who worked with the Minnesota Twins on the installation of induction loop systems at ticket windows to ensure that individuals with hearing disabilities can communicate effectively with ticket agents in their new ballparks.

Cost Impact: The code change proposal will increase the cost of construction

Public Hearing: Committee:	AS	AM	D
Assembly:	ASF	AMF	DF

ICCFILENAME:Marinelli-E2-1108.2.6.1.2

E176–09/10

1108.2.7.2, 1108.2.7.2.1, 1108.2.7.2.2

Proponent: Ed Roether, Populous (Formerly HOK Sport Venue Event), representing self

1. Revise as follows:

1108.2.7.2 Public address systems. Where stadiums, arenas and grandstands have 15,000 fixed seats or more and provide audible public announcements, they shall also provide equivalent text information regarding events and facilities in compliance with Sections 1108.2.7.2.1 and 1108.2.7.2.2 pre-recorded or real-time captions of those audible public announcements.

2. Delete without substitution:

~~1108.2.7.2.1 Prerecorded text messages. Where electronic signs are provided and have the capability to display prerecorded text messages containing information that is the same, or substantially equivalent, to information that is provided audibly, signs shall display text that is equivalent to audible announcements.~~

~~**Exception:** Announcements that cannot be prerecorded in advance of the event shall not be required to be displayed.~~

~~1108.2.7.2.2 Real-time messages. Where electronic signs are provided and have the capability to display real-time messages containing information that is the same, or substantially equivalent, to information that is provided audibly, signs shall display text that is equivalent to audible announcements.~~

Reason: This proposal addresses several things. First, currently any grandstand with a public address system requires equivalent text to the information announced, i.e. captioning, and in a little league ballpark the seating would meet the definition of a grandstand and there will likely be a microphone with a loud speaker that would address the public. Therefore, this small volunteer baseball field could be interpreted as a grandstand with a public address system. There are many similar facilities that would be caught by this requirement without any practical way of complying. A facility requires a certain amount of sophistication before captioning can be readily possible. These smaller facilities are often staffed by volunteers rather than the trained staff found in the more sophisticated facilities. Solving the technological challenges alone does not assure effective text to audible announcements, i.e. captioning. This proposal would apply to only those stadiums, arenas and grandstands that would have adequate infrastructure to adequately caption announcements.

The use of the term electronic sign is improper as it relates to providing substantially equivalent text information to audible announcements. "Captions" of audible information is nationally recognized as the term for providing text information that matches audible announcements. Captioning information that is announced over the PA system was ruled as needed for equivalent communication with persons having a hearing impairment in a court decision over civil rights under the Americans with Disabilities Act (ADA) at Fed Ex Field, dated September 30, 2008. It was also proposed as a requirement in the Proposed Rule by the Department of Justice, dated June 17, 2008, to establish new design guidelines for the ADA. Finally, this proposal maintains the use of either pre-recorded or real-time captions of audible announcements at the discretion of the facility as currently required. However, it eliminates the exception for not requiring announcements that cannot be prerecorded in advance under Section 1108.2.7.2.1.

Cost Impact: This code change proposal will not increase the cost of construction overall even though it may increase cost to some facilities and decrease cost to others.

Public Hearing: Committee:	AS	AM	D
Assembly:	ASF	AMF	DF

ICCFILENAME:Roether-E1-1108.2.7.2

E177-09/10 1108.2.9

Proponent: Curt Wiehle, Minnesota Construction Codes and Licensing Division, representing CCLD

Revise as follows:

1108.2.9 Dining and drinking areas. In dining and drinking areas, ~~the total~~ all interior and exterior floor areas ~~allotted for seating and tables~~ shall be accessible.

Exceptions:

1. An accessible route between accessible levels and stories above or below is not required where permitted by Section 1104.4, Exception 1.
- ~~4.2.~~ In buildings or facilities not required to provide an accessible route between ~~levels stories~~, an accessible route to a mezzanine ~~seating area~~ is not required, provided that the mezzanine contains less than 25 percent of the total area and the same services, decor and amenities are provided in the accessible area.
- ~~2.3.~~ In sports facilities, tiered dining areas providing seating required to be accessible shall be required to have accessible routes serving at least 25 percent of the dining area, provided that accessible routes serve accessible seating and where each tier is provided with the same services.
4. Employee only work areas shall comply with Sections 1103.2.3 and 1104.3.1.

Reason: Add drinking areas to clarify the intent that this section applies to restaurants and bars, and for consistency with Section 1108.2.8.1. Add interior and exterior spaces to include decks and patios. Delete seating and tables to include all types of public areas such as standing or game areas.

Exception 1 is added because the charging statement literally includes every level including stories.

The term level makes exception 2 irrelevant. A level is any change in elevation and all levels are required to be accessible. Stories is the term used in ADAAG. Décor is added because the mezzanine could provide something unique such as an exterior deck or exceptional exterior views. Decor is used in ADAAG.

Exception 4 is added due to the modification to simplify the charging statement which would cover employee and public areas.

Cost Impact: The code change proposal will not increase the cost of construction.

Public Hearing: Committee:	AS	AM	D
Assembly:	ASF	AMF	DF

ICCFILENAME:Wiehle-E23-1108.2.9

E178–09/10

1108.3.2 (New)

Proponent: Joseph R. Hetzel, Thomas Associates Inc. representing the Door & Access Systems Manufacturers Association

Add new text as follows:

1108.3 Self-service storage facilities. Self-service storage facilities shall provide accessible individual self-storage spaces in accordance with Table 1108.3.

TABLE 1108.3
ACCESSIBLE SELF-SERVICE STORAGE FACILITIES
(Portions of table not shown remain unchanged)

1108.3.1 Dispersion. Accessible individual self-service storage spaces shall be dispersed throughout the various classes of spaces provided. Where more classes of spaces are provided than the number of required accessible spaces, the number of accessible spaces shall not be required to exceed that required by Table 1108.3. Accessible spaces are permitted to be dispersed in a single building of a multibuilding facility.

1108.3.2 Access doors. Where upward acting doors are provided as the only means of access, such doors shall meet the following requirements:

1. Handles, pulls, latches, locks, and other operable parts shall have a shape that is easy to grasp with one hand and does not require tight grasping, pinching, or twisting of the wrist to operate. Operable parts of such hardware shall be 34 inches (865 mm) minimum and 48 inches (1220 mm) maximum above the floor.
2. Hardware used for operation shall be exposed and usable.
3. For manually operated doors, the force for manual operation shall not exceed 15 pounds (66.6 N) and the door size shall not exceed 8 feet 8 inches (2.64 m) wide by 8 feet (2.44 m) high.
4. Automatic doors shall include a means of disabling automatic operation devices in order to allow for emergency manual operation. The opening force for emergency operation shall not exceed 25 pounds (111 N).

Reason: Sections 1108.3 and 1108.3.1 are shown for context only. Self-service storage facilities often use upward acting doors as the sole means of accessing storage space. When a particular storage space is required to be accessible, in some cases another type of door meeting accessibility requirements cannot be practically provided. Currently, ICC/ANSI A117.1 does not address upward acting doors. The proposed requirements for operable parts, hardware and manual operation force are taken directly from A117.1 as applied to other types of doors. The maximum force limitations for operating a door, and the corresponding maximum size for a manually operated door, are based on design limitations inherent in upward acting doors. The maximum size is also common to self-service storage facilities.

Cost Impact: The proposal will increase the cost of construction if the automatic door option is chosen. However, automatic doors have advantages over manually operated doors from an operational standpoint, and if only accessible doors are automated, the impact on project cost should be minimal.

Public Hearing: Committee:	AS	AM	D
Assembly:	ASF	AMF	DF

ICCFILENAME:Hetzel-E1-1108.3.2

E179–09/10

1108.5 (New), Chapter 35

Proponent: Marsha K. Mazz, U.S. Architectural and Transportation Barriers Compliance Board (Access Board)

1. Add new text as follows:

1108.5 Classroom acoustics. Classrooms in Group E occupancies shall meet the acoustical performance criteria in ANSI/ASA S12.60, Part 1.

Exception: Relocatable classrooms shall be permitted to comply with ANSI/ASA S12.60, Part 2.

2. Add new standard to Chapter 35 as follows:

American National Standards Institute (ANSI)

ANSI/ASA S12.60-2010/Part 1 Acoustical Performance Criteria, Design Requirements, and Guidelines for Schools
ANSI/ASA S12.60-200X/Part 2 Acoustical Performance Criteria, Design Requirements, and Guidelines for Schools, Relocatable Classroom Factors.

Reason: This code change proposes to reference two new standards: ANSI/ASA S12.60-2010/Part 1 Acoustical Performance Criteria, Design Requirements, and Guidelines for Schools and ANSI/ASA S12.60-200X/Part 2 Acoustical Performance Criteria, Design Requirements, and Guidelines for Schools, Relocatable Classroom Factors.

Acoustical performance is an important consideration in the design of classrooms. The proposed standard sets specific criteria for maximum background noise (35 decibels) and reverberation time (0.6 to 0.7 seconds) for unoccupied classrooms. Research indicates that levels of background noise and reverberation little noticed by adults, who are mature and skillful listeners, adversely affect learning environments for young children, whose neurological development is incomplete until late adolescence.¹ Amplification cannot remedy poor classroom acoustics because they amplify both wanted and unwanted sound. This code change will remove educational barrier for children who have hearing loss and those who use cochlear implants. In addition, children who have temporary hearing loss, who may comprise up to 15% of the school age population according to the Centers for Disease Control (CDC), will also benefit, as will children who have speech impairments or learning disabilities and those whose home language is different. Without improvements to the listening environment, children of all backgrounds, ages, and abilities are at risk of educational delay and failure.

Background: In 1998, the U.S. Access Board joined with the **Acoustical Society of America (ASA)** to support the development of a classroom acoustics standard. This resulted in the publication of the first ANSI/ASA S12.60-2002 (R 2009) Acoustical Performance Criteria, Design Requirements and Guidelines for Schools which was reaffirmed in 2009. The standard is now being reformatted to make it more easily interpreted and enforced. Additionally, it will include a new Part 2 to better address relocatable classrooms with support from the Modular Building Institute. We understand that the new editions will be published in 2009 (Part 2) and 2010 (Part 1) in time for consideration at the Final Action Hearings.

Supporting Data: In a large study of students in London and Munich schools, classroom noise levels were related to standardized achievement scores showing that higher noise levels resulted in poorer standardized test scores.^{2,3} Similar scores were reported by Armstrong International.

Bibliography

1. Ponton, C., Eggermont, J., Kwong, B. & Don, M. (2000) Maturation of human central auditory system activity: Evidence from multi-channel evoked potentials, Clinical Neurophysiology 111, 220 – 236.
2. Shield, B and Dockrell J (2008) The effects of environmental and classroom noise on the academic attainments of primary school children, J. Acoust. Soc. Am. Volume 123, 133-144
3. Hygge, S, Evans, G W. & Bullinger, M (2002) A Prospective Study of Some Effects of Aircraft Noise on Cognitive Performance in Schoolchildren. Psychological Science 13 (5), 469-474.

Cost Impact: This code change will increase the cost of construction. Evidence obtained from the State of Connecticut where the ANSI/ASA S12.60-2002 is applicable under state law is that cost increases have been nominal even for modular construction. Data from the UK where a similar standard has been applicable over the past five years indicates an average increase of 1.5% in new school construction. We anticipate that any costs attributable to this code change would be offset by the increased availability of Federal funds through the American Recovery and Reinvestment Act. A funding bill has passed in the U.S. House of Representatives which will support school sustainability improvements, specifically including improvements to acoustical environments.

Analysis: A review of the standards proposed for inclusion in the code, ANSI/ASA S12.60-2010/Part 1 and ANSI/ASA S12.60/Part 2, for compliance with ICC criteria for referenced standards given in Section 3.6 of Council Policy #CP 28 will be posted on the ICC website on or before September 24, 2009.

Public Hearing: Committee:	AS	AM	D
Assembly:	ASF	AMF	DF

ICCFILENAME:Mazz-E4-1108.5

E180–09/10

1109.2

Proponent: Curt Wiehle, Minnesota Construction Codes and Licensing Division, representing CCLD

Revise as follows:

1109.2 Toilet and bathing facilities. Each toilet room and bathing room shall be accessible. Where toilet rooms or bathing facilities are located on a floor level is not required to be connected by an accessible route, the ~~only toilet~~

~~rooms or bathing rooms provided within the facility shall not be located on the inaccessible~~ same type of facilities shall be located on an accessible floor. At least one of each type of fixture, element, control or dispenser in each accessible toilet room and bathing room shall be accessible.

Exceptions:

1. In toilet rooms or bathing rooms accessed only through a private office, not for common or public use and intended for use by a single occupant, any of the following alternatives are allowed:
 - 1.1. Doors are permitted to swing into the clear floor space, provided the door swing can be reversed to meet the requirements in ICC A117.1;
 - 1.2. The height requirements for the water closet in ICC A117.1 are not applicable;
 - 1.3. Grab bars are not required to be installed in a toilet room, provided that reinforcement has been installed in the walls and located so as to permit the installation of such grab bars; and
 - 1.4. The requirement for height, knee and toe clearance shall not apply to a lavatory.
2. This section is not applicable to toilet and bathing rooms that serve dwelling units or sleeping units that are not required to be accessible by Section 1107.
3. Where multiple single-user toilet rooms or bathing rooms are clustered at a single location, at least 50 percent but not less than one room for each use at each cluster shall be accessible.
4. Where no more than one urinal is provided in a toilet room or bathing room the urinal is not required to be accessible.
5. Toilet rooms that are part of critical care or intensive care patient sleeping rooms are not required to be accessible.

Reason: This is an equity issue. The current text would allow separate gender facilities on the inaccessible floor and only a unisex on the accessible floor. Or, conversely, the only unisex room could be located on an inaccessible floor. As amended, the accessible facilities are required to be of the same type as on the inaccessible floor.

Cost Impact: The code change proposal will increase the cost of construction.

Public Hearing: Committee:	AS	AM	D
Assembly:	ASF	AMF	DF

ICCFILENAME:Wiehle-E25-1109.2

E181-09/10 1109.2

Proponent: Hope Reed, New Mexico Governor's Commission on Disability, representing the agency

Revise as follows:

1109.2 Toilet and bathing facilities. Each toilet room and bathing room shall be accessible. Where a floor level is not required to be connected by an accessible route, the only toilet rooms or bathing rooms provided within the facility shall not be located on the inaccessible floor. At least one of each type of fixture, element, control or dispenser in each accessible toilet room and bathing room shall be accessible.

Exceptions:

1. In toilet rooms or bathing rooms accessed only through a private office, not for common or public use and intended for use by a single occupant, any of the following alternatives are allowed:
 - 1.1. Doors are permitted to swing into the clear floor space, provided the door swing can be reversed to meet the requirements in ICC A117.1;
 - 1.2. The height requirements for the water closet in ICC A117.1 are not applicable;
 - 1.3. Grab bars are not required to be installed in a toilet room, provided that reinforcement has been installed in the walls and located so as to permit the installation of such grab bars; and
 - 1.4. The requirement for height, knee and toe clearance shall not apply to a lavatory.
2. This section is not applicable to toilet and bathing rooms that serve dwelling units or sleeping units that are not required to be accessible by Section 1107.
3. Where multiple single-user toilet rooms or bathing rooms are clustered at a single location, at least 50 percent but not less than one room for each use at each cluster shall be accessible.
4. Where no more than one urinal is provided in a toilet room or bathing room, the urinal is not required to be accessible.

5. Toilet rooms that are part of critical care or intensive care patient sleeping rooms are not required to be accessible.
6. Where toilet facilities are primarily for children's use, required accessible water closets, toilet compartments and lavatories shall be permitted to comply with children's provision of ICC A117.1.

Reason: The added text provides "scoping" for children's water closets, toilet compartments and lavatories within the "ICC/ANSI A117.1-2003 Accessible and Usable Buildings and Facilities" section 604.1 Exception and 604.10 which identifies children's wheelchair accessible fixtures. Designers are unclear whether they need to provide additional accessible fixtures for children beyond those required for adults, and how many additional children's fixtures are needed.

Since adults are the minority in areas primarily used by children (such as in the preschool and kindergarten school wing, children's library and children's museum) the children's population needs to be adequately served with the proper number of children's accessible fixtures. Adults fixtures should be provided in other areas where there is a mix of all ages including staff, parents, students and the general public.

The added text makes it clear that children's wheelchair accessible water closets, toilet compartments and lavatories that are provided primarily for children's use may be substituted for the required number of adult fixtures in that area. No additional fixtures are required for children beyond the occupancy requirement. We use similar language in the New Mexico Building Code.

Cost Impact: The code change proposal will not increase the cost of construction.

Public Hearing: Committee:	AS	AM	D
Assembly:	ASF	AMF	DF

ICCFILENAME:ReedH-E1-1109.2

E182-09/10

1109.2

Proponent: Robert J. Heil, Code Inspections, Inc., representing Pennsylvania Association of Building Code Officials, Inc.

Revise as follows:

1109.2 Toilet and bathing facilities. Each toilet room and bathing room shall be accessible. Where a floor level is not required to be connected by an accessible route, the only toilet rooms or bathing rooms provided within the facility shall not be located on the inaccessible floor. At least one of each type of fixture, element, control or dispenser in each accessible toilet room and bathing room shall be accessible.

Exceptions:

1. In toilet rooms or bathing rooms accessed only through a private office, not for common or public use and intended for use by a single occupant, any of the following alternatives are allowed:
 - 1.1. Doors are permitted to swing into the clear floor space, provided the door swing can be reversed to meet the requirements in ICC A117.1;
 - 1.2. The height requirements for the water closet in ICC A117.1 are not applicable;
 - 1.3. Grab bars are not required to be installed in a toilet room, provided that reinforcement has been installed in the walls and located so as to permit the installation of such grab bars; and
 - 1.4. The requirement for height, knee and toe clearance shall not apply to a lavatory.
2. This section is not applicable to toilet and bathing rooms that serve dwelling units or sleeping units that are not required to be accessible by Section 1107.
3. Where multiple single-user toilet rooms or bathing rooms are clustered at a single location, at least 50 percent but not less than one room for each use at each cluster shall be accessible.
4. Where no more than one urinal is provided in a toilet room or bathing room, the urinal is not required to be accessible.
5. Toilet rooms that are part of critical care or intensive care patient sleeping rooms are not required to be accessible.
6. Where a story or mezzanine is not required to be served by an accessible route in accordance with Section 1104.4 and the occupant load of that level is less than 15, then toilet rooms located on that level are not required to be accessible.

Reason: For a small floor level that is permitted to not be on an accessible route, with a limited occupancy, the requirement to have an accessible toilet room(s) occupies a disproportionate amount of space and does little to serve accessible needs.

Cost Impact: This code change proposal will not increase the cost of construction.

Public Hearing: Committee:	AS	AM	D
Assembly:	ASF	AMF	DF

ICCFILENAME:Heil-E1-1109.2

E183–09/10

1109.4

Proponent: Curt Wiehle, Minnesota Construction Codes and Licensing Division, representing CCLD

Revise as follows:

1109.4 Kitchens and kitchenettes. Where kitchens and kitchenettes are provided in accessible spaces or rooms, ~~they at least one kitchen~~ shall be accessible ~~in accordance with ICC A117.1.~~

Reason: It is excessive to require all kitchens to be accessible in spaces that have multiple kitchens such as a classroom. The reference to ICC A117.1 is unnecessary as it is referenced at Section 1101.2 for the entire chapter.

Cost Impact: The code change proposal will not increase the cost of construction.

Public Hearing: Committee:	AS	AM	D
Assembly:	ASF	AMF	DF

ICCFILENAME:Wiehle-E26-1109.4

E184–09/10

1109.5.1, 1109.5.2

Proponent: Hope Reed, Governor's Commission on Disability, representing the agency

Revise as follows:

1109.5 Drinking fountains. Where drinking fountains are provided on an exterior site, on a floor or within a secured area, the drinking fountains shall be provided in accordance with Section 1109.5.1 and 1109.5.2.

1109.5.1. Minimum number. No fewer than two drinking fountains shall be provided. One drinking fountain shall comply with the requirements for people who use a wheelchair and one drinking fountain shall comply with the requirements for standing persons.

Exception Exceptions:

1. A single drinking fountain that complies with the requirements for people who use a wheelchair and standing persons shall be permitted to be substituted for two separate drinking fountains.
2. Where drinking fountains are primarily for children's use, drinking fountains for people using wheelchairs shall be permitted to comply with the children's provisions in ICC A117.1 and drinking fountains for standing children shall be permitted to provide the spout at 30" (762 mm) minimum above the floor.

1109.5.2 More than the minimum number. Where more than the minimum number of drinking fountains specified in Section 1109.5.1 are provided, 50 percent of the total number of drinking fountains provided shall comply with the requirements for persons who use a wheelchair and 50 percent of the total number of drinking fountains provided shall comply with the requirements for standing persons.

Exception Exceptions:

1. Where 50 percent of the drinking fountains yields a fraction, 50 percent shall be permitted to be rounded up or down, provided that the total number of drinking fountains complying with this section equals 100 percent of the drinking fountains.
2. Where drinking fountains are primarily for children's use, drinking fountains for people using wheelchairs shall be permitted to comply with the children's provisions in ICC A117.1 and drinking fountains for standing children shall be permitted to provide the spout at 30" (762 mm) minimum above the floor.

Reason: The added text provides "scoping" for children's drinking fountains within the "ICC/ANSI A117.1-2003 Accessible and Usable Buildings and Facilities" section 602.2 exception. Designers are unclear where and when to provide accessible fixtures for children. The IBC needs to scope the children drinking fountains and state they may be substituted for adult fixtures. Additional fixtures are not needed.

Since adults are the minority in areas primarily used by children (such as in the preschool and kindergarten school wing, children's library and children's museum) the children's population needs to be adequately served with proper number of children's accessible fixtures. Adult fixtures are typically provided where there is a mix of all ages including staff, parents, students and the general public.

Prior to the development of children standards in A117.1 the standing drinking fountains for children were typically located with the spout 30" above the floor. The A117.1 had a children's group and tall people group working on the drinking fountains at the same time and the standing requirement was overlooked for children's areas. This proposal is intended to override the adult standing requirement and provide convenient standing children's access.

See companion proposal for 1109.5.2.

Cost Impact: The code change proposal will not increase the cost of construction.

Public Hearing:	Committee:	AS	AM	D
	Assembly:	ASF	AMF	DF

ICCFILENAME:ReedH-E2-1109.5.1

E185-09/10

1109.5.1

Proponent: James W. McCall, AIA, Slonaker McCall Architects, representing self

Revise as follows:

1109.5.1 Minimum number. No fewer than two drinking fountains shall be provided. One drinking fountain shall comply with the requirements for people who use a wheelchair and one drinking fountain shall comply with the requirements for standing persons.

Exceptions:

1. A single drinking fountain that complies with the requirements for people who use a wheelchair and standing persons shall be permitted to be substituted for two separate drinking fountains.
2. Where Group B, E, I and M occupancies have an occupant load not exceeding 100 persons and where only one drinking fountain is required in accordance with Table 2902.2, the drinking fountain shall comply with the requirements for people who use a wheelchair and a second drinking fountain for standing persons shall not be required.

Reason: Where the plumbing fixture requirement for a small occupancy requires that a single drinking fountain be installed, IBC Section 1109.5.1 currently requires that at least two drinking fountains be installed, one mounted high and one mounted low. In small establishments (those having an occupant load of 100 or less), this is a significant financial burden as well as a waste of precious space for a fixture that will rarely be used especially if the local potable water supply tastes bad. Many small establishments provide bottled water dispensers for their customers and employees because the cost is insignificant and it is often viewed as a "perk" for both customers and workers. I have proposed to a change to the IPC to allow small establishments to substitute bottled water dispensers (or bottled water coolers) for 100 percent of the required number of drinking fountains. However, if the designer chooses to provide a drinking fountain for a small establishment, he should not be penalized by having to supply two drinking fountains. Provision of drinking fountains in small B, E, I and M occupancies should be optional, and if one is provided, the designer should not have to provide two.

Cost Impact: The code change proposal will not increase the cost of construction. (It will decrease for small projects.)

Public Hearing:	Committee:	AS	AM	D
	Assembly:	ASF	AMF	DF

ICCFILENAME: McCall-E1-1109.5

E186-09/10

1109.6 (New)

Proponent: Marsha K. Mazz, U.S. Architectural and Transportation Barriers Compliance Board (Access Board)

Add new text as follows:

1109.6 Saunas and Steam Rooms. Where provided, saunas and steam rooms shall comply with ICC A117.1.

Exception: Where saunas or steam rooms are clustered at a single location, no more than 5 percent of the saunas and steam rooms, but no fewer than one, of each type in each cluster shall be required to comply with ICC A117.1.

Reason: This proposal provides scoping for saunas and steam rooms which are addressed in new Chapter 11 of the ICC A117.1. The proposal also harmonizes with the U.S. Access Board's 2004 ADA and ABA Accessibility Guidelines Section 241 which establishes a reasonable requirement for access to such facilities.

Cost Impact: This code change will increase the cost of construction. However, because these changes are harmonized with the U.S. Access Board's ADA and ABA Accessibility Guidelines, costs associated with compliance cannot be avoided once the U.S. Department of Justice adopts the guidelines as enforceable standards under the Americans with Disabilities Act. The guidelines have already been adopted as enforceable standards under the Architectural Barriers Act applicable to federally funded facilities.

Public Hearing: Committee:	AS	AM	D
Assembly:	ASF	AMF	DF

ICCFILENAME:Mazz-E3-1109.6

E187-09/10

1109.6, 1109.6.1 (New), 1109.6.2 (New)

Proponent: Don Davies, Salt Lake City Corporation, representing the Utah Chapter of ICC

1. Revise text as follows:

1109.6 Elevators. Passenger elevators on an accessible route shall be accessible and comply with Section ~~3004.3~~ 3001.

2. Add new text as follows:

1109.6.1 Limited use limited application elevators. Limited use limited application elevators are permitted to be a part of a required accessible route. The maximum rise of the car platform shall not exceed 25 feet (7.6 m).

1109.6.2 Private Residence elevators. Private residence elevators are permitted to be part of a required accessible route within or serving an individual dwelling unit or sleeping unit. The maximum rise of the car platform shall not exceed 50 feet (15 m).

Reason: The code currently scopes the provisions for passenger elevators (Section 1109.6). A reference to Section 3001 will pick up a reference to safety standard, ASME A17.1, as well as the accessibility standard, ICC A117.1. It is unclear to those unfamiliar with ASME A17.1 that LULAs and private residence elevators are 'passenger elevators' with limited applications. The 25 feet of vertical rise for LULAs is found in ASME A17.1 Section 5.2.1.16.5. The 50 feet of vertical rise for private residence elevators is found in ASME A17.1 Section 5.3.1.10.3. Since the code is very explicit on the limitations of lifts in new construction it seems reasonable that some guidance be placed in the body of the code scoping the provisions and stating the limitations of these types of elevators.

Cost Impact: The code change proposal will not increase the cost of construction.

Public Hearing: Committee:	AS	AM	D
Assembly:	ASF	AMF	DF

ICCFILENAME:Davies-E1-1109.7

E188-09/10

1109.8, 1109.8.1, 1109.8.3

Proponent: Curt Wiehle, Minnesota Construction Codes and Licensing Division, representing CCLD

Revise as follows:

1109.8 Storage. Where fixed or built-in storage elements such as cabinets, coat hooks, shelves, medicine cabinets, lockers, closets and drawers are provided in required accessible spaces, at least five percent, but not less than one of each type shall be accessible ~~contain storage space complying with ICC A117.1.~~

~~1109.8.1 Lockers.~~ Where ~~lockers are provided in accessible spaces, at least five percent, but not less than one, of each type shall be accessible.~~ **Equity.** Accessible facilities and spaces shall be provided with the same storage elements as provided in the similar non-accessible facilities and spaces.

1109.8.2 Shelving and display units. Self-service shelves and display units shall be located on an accessible route. Such shelving and display units shall not be required to comply with reach-range provisions.

~~**1109.8.3 Coat hooks and shelves.** Where coat hooks and shelves are provided in toilet rooms or toilet compartments or in dressing, fitting or locker rooms, at least one of each type shall be accessible and shall be provided in accessible toilet rooms without toilet compartments, accessible toilet compartments and accessible dressing, fitting and locker rooms.~~

Reason: This modification simplifies the section and maintains the intent by providing a measurable 5%, not less than one, criteria to the entire list of items.

The concept of Section 1109.8.3 is reworded to include all of the items from the charging statement and relocated to Section 1109.8.1.

Cost Impact: The code change proposal will not increase the cost of construction.

Public Hearing:	Committee:	AS	AM	D
	Assembly:	ASF	AMF	DF

ICCFILENAME:Wiehle-E27-1109.8

E189-09/10

1109.8.4, Appendix E105.4

Proponent: Donald E. Irwin, Program Manager, Delivery, Collection & Carrier Equipment, representing United States Postal Service

1. Delete without substitution:

~~**E105.4 Mailboxes.** Where mailboxes are provided in an interior location, at least 5 percent, but not less than one, of each type shall comply with ICC A117.1. In residential and institutional facilities, where mailboxes are provided for each dwelling unit or sleeping unit, mailboxes complying with ICC A117.1 shall be provided for each unit required to be an Accessible unit.~~

2. Add new text as follows:

1109.8.4 Centralized Mailboxes and Common Use Parcel Lockers. Centralized mailboxes, which consist of individual mail delivery compartments that are each initially assigned to one address but which are always subject to subsequent reassignment and/or exchange with another compartment, shall be subject to the following accessibility requirements. In non-residential facilities, where mailboxes and common use parcel lockers are provided in a grouped or centralized location, at least 5 percent, but not less than one, of each mailbox type and common use parcel locker type shall comply with ICC A117.1. In residential facilities, where mailboxes and common use parcel lockers are provided in a grouped or centralized location for all dwelling or sleeping units, at least 5 percent, but not less than one, of each mailbox type and common use parcel locker type shall comply with ICC A117.1. In residential and institutional facilities required to have Accessible units or Type A units, all mailboxes for these units shall comply with ICC A117.1.

Reason: The IBC, which is already recognized as an FHA Safe Harbor, needs to address mailbox accessibility directly, not via the optional Appendix E entry (E105.4). There is confusion in the construction industry, the accessibility world, and the courts regarding what mailbox accessibility requirements are for "covered multi-family dwellings" of the Fair Housing Amendments Act of 1988. This confusion is impacting the construction industry and Postal operations while affording suspect at best benefits for the full range of the mobility-disabled community that the Postal Service serves. With USPS requirements restricting mail delivery compartments from being located below a 28 inch wall height, the ICC/ANSI A117.1 upper reach limit of 48 inches only leaves 20 inches of usable wall height. This very restrictive usable wall height, coupled with current misinterpretations of FHA mailbox requirements, is resulting in mailroom designs that are almost double the size they should be. This proposed entry would address this misinterpretation, maintain compliance with all FHA statutory and regulatory requirements, re-establish FHA mailbox accessibility conformity with other accessibility requirements, and formally support what had been in place as the de facto FHA mailbox accessibility requirements for at least the first 15 years after the March 13, 1991 FHA implementation date.

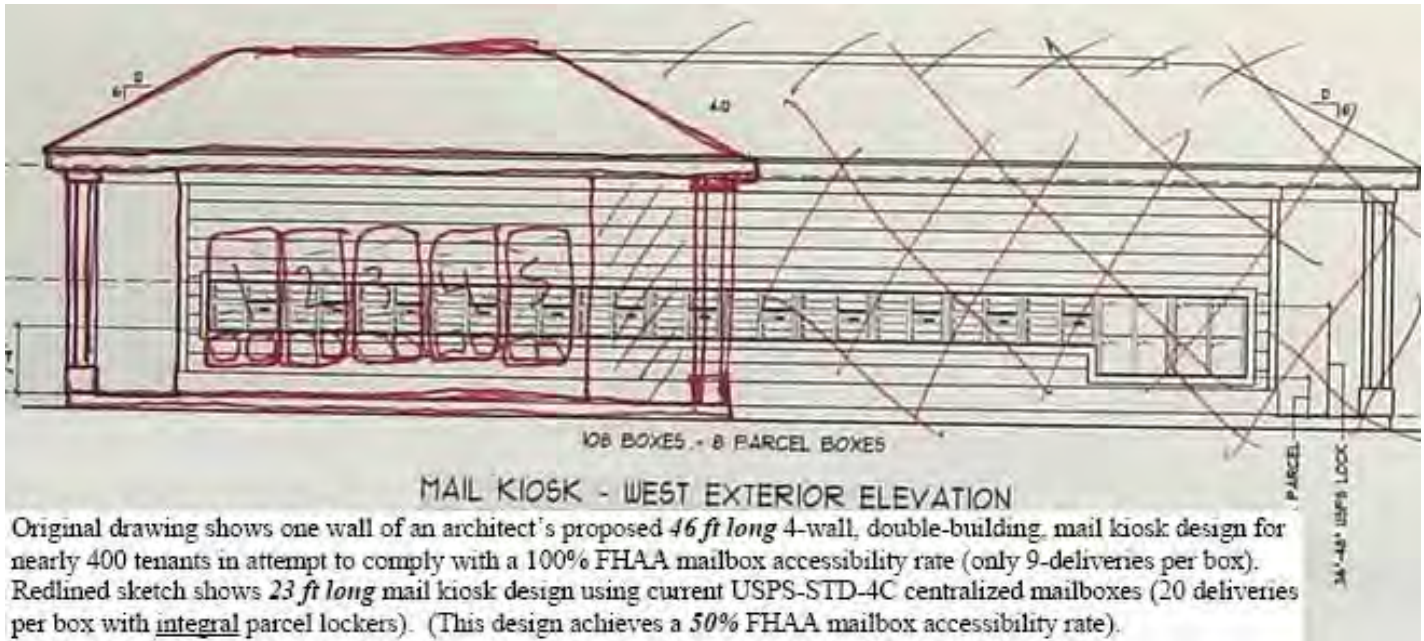

Original drawing shows one wall of an architect's proposed 46 ft long 4-wall, double-building mail kiosk design for nearly 400 tenants in attempt to comply with a 100% FHAA mailbox accessibility rate (only 9-deliveries per box). Redlined sketch shows 23 ft long mail kiosk design using current USPS-STD-4C centralized mailboxes (20 deliveries per box with integral parcel lockers). (This design achieves a 50% FHAA mailbox accessibility rate).

Cost Impact: The code change proposal will not increase the cost of construction.

Public Hearing: Committee: AS AM D
 Assembly: ASF AMF DF

ICCFILENAME:Irwin-G1-E105.4

E190-09/10

1109.15 (New), 1109.15.1 (New), 1109.15.1.1 (New), 1109.15.1.2 (New), 1109.15.2 (New), Appendix E105.4

Proponent: Cheryl Kent, representing US Department of Housing and Urban Development

1. Add a new text as follows:

1109.15. Mailboxes. Where mailboxes are provided, accessible mailboxes shall be provided in accordance with 1109.15.1 and 1109.15.2.

1109.15.1 Dwelling units and sleeping units. Mailboxes serving dwelling units or sleeping units shall be accessible in accordance with 1109.15.1.1 or 1109.15.1.2.

1109.15.1.1 Individual Mailboxes. Where a mailbox is provided at a dwelling unit or sleeping unit that is required to be an Accessible unit, Type A unit or Type B unit, the mailbox shall be accessible.

1109.15.1.2 Clustered Mailboxes. Where clustered mailboxes serve dwelling units or sleeping units that are required to be Accessible units, Type A units or Type B units, the mailboxes assigned to each Accessible unit, Type A unit and Type B units shall be accessible.

1109.15.2 Other occupancies. Where mailboxes are provided in occupancies not falling within the purview of Section 1109.15.1 and are provided in an interior location, at least 5 percent, but not less than one, of each type shall be accessible.

2. Delete without substitution:

E105.4 Mailboxes. Where mailboxes are provided in an interior location, at least 5 percent, but not less than one, of each type shall comply with ICC A117.1. In residential and institutional facilities, where mailboxes are provided for each dwelling unit or sleeping unit, mailboxes complying with ICC A117.1 shall be provided for each unit required to be an Accessible unit.

Reason: This proposed change is intended to ensure that the IBC is consistent with the accessibility requirements of the Fair Housing Act, HUD's implementing regulations, and HUD's Fair Housing Accessibility Guidelines (the Guidelines). It has come to HUD's attention that Section E105.4 is being interpreted as applying to mailboxes serving Type B dwelling units. This was not HUD's understanding of the IBC. Instead, our understanding was that Section 1107.3 covered mailboxes as well as all other types of public and common use facilities serving Type B dwelling units, and that because there were no requirements to scope less than 100% of mailboxes, that the IBC was consistent with HUD's regulations and the Guidelines. However, because Appendix E includes text for mailboxes at Section E105.4 and it appears some developers are interpreting E105.4 as applying a similar requirement for Type B dwelling units, we are recommending that Section E105.4 be struck out and a new section be added as outlined above to Chapter 11 of the IBC. The above text is intended to ensure that accessibility requirements for Type B dwelling units, Accessible Units and Type A units, as well as for mailboxes serving other types of occupancies are all covered in Chapter 11 of the IBC.

The Fair Housing Act, its implementing regulations and the Guidelines require that covered multifamily dwellings contain accessible public and common use areas. Requirement 2 of the Guidelines covers public and common use areas, and provides a chart entitled "Basic Components for Accessible and Usable Public and Common Use Areas or Facilities." Mailboxes are addressed in Item 14 of the chart, which specifically references the primary sections of 1986 ANSI A117.1 that apply to these elements or spaces. Item 14 encompasses Sections 4.1 through 4.30 of the standard, and the relevant accessibility standards applicable for mailboxes typically would include the requirements for an accessible route, clear floor or ground space, accessible reach ranges, and accessible controls and operating mechanisms. In a building with one or more elevators, all of the mailboxes would have to fall within these reach ranges. In a building without an elevator, mailboxes serving the ground floor units would have to meet those requirements. Although HUD's Fair Housing Accessibility Guidelines reference the 1986 ANSI A117.1 standard, which provides for side reach ranges of 9 inches minimum to 54 inches maximum, we recognize the IBC references more recent editions of A117.1. We are not, however, recommending changes to the A117.1 through this proposal.

We would like to ensure that architects and builders involved in designing and constructed buildings that are covered by the Fair Housing Act provide for accessibility of mailboxes consistent with HUD's regulations and Guidelines. Developers who deviate from these standards by providing mailboxes at higher reach ranges have been subject to enforcement proceedings brought by HUD as well as litigation brought by the Department of Justice. The Department of Justice has entered into a number of consent decrees which have required the developer to change the height of mailboxes serving covered multifamily dwellings. We believe this change is needed to ensure that the IBC is consistent with the Fair Housing Act and HUD's regulations and Guidelines, and to avoid unnecessary litigation with respect to mailboxes serving Type B dwelling units.

Cost Impact: There should be no significant cost impact since the IBC has already incorporated text to assure consistency with the Fair Housing Act, HUD's regulations and the Guidelines, and this change is intended to clearly specify requirements for mailboxes serving Type B dwelling units as opposed to only generally covering all public and common use spaces serving Type B dwelling units in Section 1107.3.

Public Hearing:	Committee:	AS	AM	D
	Assembly:	ASF	AMF	DF

ICCFILENAME:Kent-E1-1109.15

E191-09/10

1109.14.4.6 (New)

Proponent: Curt Wiehle, Minnesota Construction Codes and Licensing Division, representing CCLD

Add new text as follows:

1109.14.4.6 Recreational equipment. Equipment such as play structures, amusement rides, and miniature golf are not required to be accessible.

Reason: Accessibility issues for these types of structures are outside the scope of the building code.

Cost Impact: The code change proposal will not increase the cost of construction.

Public Hearing:	Committee:	AS	AM	D
	Assembly:	ASF	AMF	DF

ICCFILENAME:Wiehle-E28-1109.14.4.6

E192-09/10

1109.14.4.6 (New)

Proponent: Curt Wiehle, Minnesota Construction Codes and Licensing Division, representing CCLD

Add new text as follows:

1109.14.4.6 Trails. Trails and outdoor recreation routes are not required to be accessible.

Reason: The Access Board revised accessibility guidelines (2004 ADA/ABA Accessibility Guidelines) include scoping and technical provisions for several types of recreation facilities, including recreational boating facilities, fishing piers and platforms, golf facilities, play areas, and swimming pools. ICC A117.1 has added the technical criteria for how to make these facilities accessible. However, neither the revised accessibility guidelines or ICC A117.1 address access to such outdoor developed areas, trails, beaches, and picnic and camping facilities. The Access Board is developing technical and scoping requirements for such outdoor developed areas. The regulatory negotiation committee's report is available at the Access Board's website (<http://www.access-board.gov/outdoor/outdoor-rec-rpt.htm>). At this time, the Access Board has decided to limit this proposed rule to outdoor developed areas designed, constructed, or altered by Federal agencies subject to the Architectural Barriers Act. At a future date, when an

assessment of the impacts on State and local governments and private entities can be prepared, the Access Board will conduct a separate rulemaking for outdoor developed areas subject to the Americans with Disabilities Act. Since the technical information is not currently in ICC A117.1, these types of facilities should not be required to be accessible by the IBC. By limiting this proposal to trails and recreation routes, the intent is to address those routes that exist simply and solely as pedestrian paths. It is not intended to apply to routes that connect buildings or facilities that are on the same site.

Cost Impact: The code change proposal will not increase the cost of construction.

Public Hearing: Committee: AS AM D
Assembly: ASF AMF DF

ICCFILENAME:Wiehle-E21-1109.14.4.7

E193-09/10

1110.4 (New), 1110.4.1 (New), 1110.4.2 (New)

Proponent: Billie Louise Bentzen, PhD, Assoc. for Education & Rehabilitation of the Blind & Visually Impaired

Add new text as follows:

1110.4 Variable Message Signs. Where provided in the locations in Sections 1110.4.1 and 1110.4.2, Variable Message Signs (VMS) shall comply with the VMS requirements of ICC A117.1

1110.4.1 Transportation facilities. Where provided in transportation facilities, variable message signs conveying transportation related information shall comply with Section 1110.4.

1110.4.2 Emergency shelters. Where provided in buildings that are designated as emergency shelters, variable message signs conveying emergency related information shall comply with Section 1110.4.

Exception: Where equivalent information is provided in an audible manner, VMS signs are not required to comply with ICC A117.1.

Reason: Variable Message Sign (VMS) requirements have been developed by the ICC A117.1 committee and added into the updated edition of the standard. This proposal will provide scoping provisions to assure that VMS signage in transportation facilities and emergency shelters is usable by most of the population. The ICC A117.1 language modifies requirements for visual signs primarily by requiring increased character height and spacing for low resolution VMS signs. Even for users with unimpaired vision, there is strong research evidence that character height in low resolution VMS such as the LED signs that are common in the transportation environment and elsewhere must be approximately 30% greater than for equivalent print signs or VMS with high resolution. The requirements for increased character height, etc. for low resolution VMS are not applicable to high resolution VMS such as video.

The proposed sections will not "require" that VMS signage be installed in any facility type, but will instead require that "where provided" within transportation facilities and emergency shelters VMS comply with the standard and are usable by most of the population.

The phrasing "conveying transportation related information" and "conveying emergency related information" was included in the sections to limit the application of the A117.1 VMS requirements to signs that are necessary for the most effective use of transportation information and information in emergency shelters. The intent of this text is that signs that present information that is not necessary for transportation or emergency use of facilities would be exempt. For example, a VMS that advertised what dining options were available in an airport would not be required to comply with the standard's VMS provisions, nor would a television set within the waiting area that had closed captioning of a news program. However any VMS that indicated what flight was departing from what gate or the time of the flight would be regulated. In the case of an emergency shelter located at a school, only the signage related to shelter would be covered. The signage dealing with the school and possibly listing what school activities were occurring that week would not be expected to comply with the VMS requirements.

Transportation facilities have been included in this proposal for several reasons. Riders with reduced vision are especially dependent on public transportation for travel and are required by the ADA to have information provided that is equivalent to that provided to riders having unimpaired vision. The proposal will coordinate the IBC requirements with those of the Americans with Disabilities Act (ADA). Currently Sections E109 and E110 in Appendix E address some signage requirements within "transportation facilities and stations" and "airports." These provisions are located within the appendix but need to be included in the IBC text to match up with the ADA. Including this text within Chapter 11 will help to make the two accessibility laws more consistent. The VMS signs are often used within transportation facilities (See Sections E109.2.2.2, E109.2.2.3, E109.2.7, E110.3) as a primary means of conveying information to riders. Since the ICC A117 committee has provided specific regulations for these signs it is appropriate to reference these provisions so that designers and code officials know exactly what the technical requirements for the signs are. As noted earlier, this section does not "require" the VMS signs but "where provided" is intended to ensure that VMS comply with the requirements that the ICC A117.1 committee has established.

Emergency shelters are typically identified by a jurisdiction when they are studying emergency planning or working with FEMA to develop community plans. Although any building could ultimately be pressed into service as an emergency shelter in some circumstances, the intent of this text is to apply the requirement only to those facilities that are designated in advance or during that planning stage as an intended shelter. In many communities this may include certain schools, civic administration buildings or even large convention facilities that a community designates as intended emergency shelters. Emergency-related information provided by VMS in emergency shelters is most likely to be information or instructions regarding additional problems, or the recovery process.

The emergency shelter provisions contain an exception that would eliminate the requirement to meet the VMS provisions of the standard. Where audible information is conveyed that is either the same or equivalent to the information provided by the sign, compliance with ICC A117.1's VMS requirements is not needed. The VMS provides the information in a visual method and the A117 provisions assure that the information is clearly visible and legible to both the general population and to people with some level of visual impairment. Providing the equivalent information in an audible manner makes the information accessible to people with severe visual impairment or who are blind.

The exception for equivalent audible information is not included within the section dealing with transportation facilities. This is done to not only coordinate with the ADA but is based upon the fact that in many such facilities the audible information is simply not easily understood. Anyone that has stood on a subway or train platform and tried to understand an audible message at the same time that the train is pulling up to the platform will understand this exclusion. Because of the problems with hearing messages in many transportation facilities, the audible message delivery is simply not considered as being adequate to replace or eliminate the clear visual sign information.

This proposal is suggesting that this VMS section be added into section 1110 in order to be located with the other signage requirements. However, it is recognized that this requirement could just as well be placed within Section 1109 and the "other features and facilities" provisions.

Cost Impact: The code change proposal will not increase the cost of construction. Because this proposal will not "require" the VMS signs to be installed, there is no increased construction cost imposed by it.

Public Hearing: Committee:	AS	AM	D
Assembly:	ASF	AMF	DF

ICCFILENAME:Bentzen-E1-1110.4 NEW

E194-09/10

1002.1 (IFC [B] 1002.1); IRC R202

Proponent: Jeff Lowinski, representing the Window and Door Manufacturers Association (WDMA)

THIS IS A 2 PART CODE CHANGE. PART I WILL BE HEARD BY THE IBC MEANS OF EGRESS COMMITTEE. PART II WILL BE HEARD BY THE IRC BUILDING/ENERGY COMMITTEE. SEE THE TENTATIVE HEARING ORDERS FOR THESE COMMITTEES.

PART I – IBC MEANS OF EGRESS

Add new definition as follows:

1002.1 (IFC [B] 1002.1) Definitions. The following words and terms shall, for the purposes of this chapter and as used elsewhere in the code, have the meanings shown herein:

LANDING. A floor area or a designated portion of a floor area, at the top or bottom of a flight of stairs, or at the top or bottom of a ramp, or at the door of an elevator.

PART II – IRC BUILDING/ENERGY

Add new definition as follows:

SECTION R202 DEFINITIONS

LANDING. A floor area or a designated portion of a floor area, at the top or bottom of a flight of stairs, or at the top or bottom of a ramp.

Reason:

(PART I) This proposal adds a definition to the IBC for "landing" which is beneficial when attempting to interpret and apply the IBC. "landing" is used in numerous locations of the IBC but is not defined.

WDMA is of the perspective that "landing" relates to the flight of stairs (or ramp) that may be near a door; and that doors, other than elevator doors, do not have "landings" necessarily associated to them. A flight of stairs, or ramp, may have a landing, and that landing may be on one side of a door. Hence there are requirements in the code for landings at doors. The proposed definition clarifies that landings are associated with stairs, ramps, or elevators.

WDMA members, as they assist their customers, have found that some jurisdictions have interpreted the exception in 1008.1.7 significantly different than the language intends.

(PART II) This proposal adds a definition to the IRC for "Landing" which is beneficial when attempting to interpret and apply the IRC. "Landing" is used in numerous locations in the IRC but currently is not defined.

WDMA is of the perspective that "landing" relates to the flight of stairs (or ramp) that may be near a door; and that doors do not have "landings" necessarily associated to them. A flight of stairs, or ramp, may have a landing, and that landing may be on one side of a door. Hence there are requirements in the code for landings at doors. The proposed definition clarifies that landings are associated with stairs or ramps.

Cost Impact: The code change proposal will not increase the cost of construction.

PART I – IBC MEANS OF EGRESS

Public Hearing: Committee:	AS	AM	D
Assembly:	ASF	AMF	DF

PART II – IRC BUILDING/ENERGY

Public Hearing:	Committee:	AS	AM	D
	Assembly:	ASF	AMF	DF

ICCFILENAME:Woestman-E2-1008.1.7