

S196-09/10
2302.1

Proposed Change as Submitted

Proponent: Edward L. Keith, PE, APA - The Engineered Wood Association

Revise as follows:

STRUCTURAL COMPOSITE LUMBER. Structural members manufactured using wood elements bonded together with exterior adhesives. Examples of structural composite lumber are:

Laminated veneer lumber (LVL). A composite of wood veneer elements with wood fibers primarily oriented along the length of the member. Veneer thickness shall not exceed 0.25 inches (6.4 mm).

Parallel strand lumber (PSL). A composite of wood strand elements with wood fibers primarily oriented along the length of the member. The least dimension of the strands shall not exceed 0.25 inches (6.4 mm) and the average length shall be a minimum of 300 times the least dimension.

Laminated strand lumber (LSL). A composite of wood strand elements with wood fibers primarily oriented along the length of the member. The least dimension of the strands shall not exceed 0.10 inches (2.54 mm) and the average length shall be a minimum of 150 times the least dimension.

Oriented strand lumber (OSL). A composite of wood strand elements with wood fibers primarily oriented along the length of the member. The least dimension of the strands shall not exceed 0.10 inches (2.54 mm) and the average length shall be a minimum of 75 times the least dimension.

Reason: ASTM Standard D5456 recognizes 4 types of structural composite lumber. This proposal adds the two types missing from the existing definition and makes them consistent with ASTM D5456

Cost Impact: The code change proposal will not increase the cost of construction.

ICCFILENAME: KEITH-S2-2302.1 Definitions

Public Hearing Results

Committee Action:

Approved as Submitted

Committee Reason: The added definitions of structural composite lumber types will clear up some confusion with their use. The definitions include some requirements and this should be corrected in the public comment phase.

Assembly Action:

None

Individual Consideration Agenda

This item is on the agenda for individual consideration because a public comment was submitted.

Public Comment:

Edward L. Keith, The Engineered Wood Association, requests Approval as Modified by this Public Comment.

Modify the proposal as follows:

STRUCTURAL COMPOSITE LUMBER. Structural members manufactured using wood elements bonded together with exterior adhesives. Examples of structural composite lumber are:

Laminated veneer lumber (LVL). A composite of wood veneer elements with wood fibers primarily oriented along the length of the member, where the veneer element ~~Veneer~~ thicknesses are 0.25 inches (6.4 mm) or less.

Parallel strand lumber (PSL). A composite of wood strand elements with wood fibers primarily oriented along the length of the member, ~~The,~~ where the least dimension of the wood strands ~~shall not exceed elements is~~ 0.25 in. (6.4 mm) or less and ~~the their~~ average lengths ~~shall be a minimum~~ are a minimum of 300 times the least dimension ~~of the wood strand elements.~~

Laminated strand lumber (LSL). A composite of wood strand elements with wood fibers primarily oriented along the length of the member, ~~The,~~ where the least dimension of the wood strands ~~shall not exceed elements is~~ 0.10 in. (2.54 mm) or less and ~~the their~~ average lengths ~~shall be a minimum~~ are a minimum of 150 times the least dimension ~~of the wood strand elements.~~

Oriented strand lumber (OSL). A composite of wood strand elements with wood fibers primarily oriented along the length of the member. ~~The, where the least dimension of the wood strands shall not exceed elements is 0.10 in. (2.54 mm) or less and the their average lengths shall be a minimum are a minimum of 75 times and less than 150 times the least dimension or more of the wood strand elements.~~

Commenter's Reason: While the provisions were approved by the Committee as proposed, it was suggested by the Committee that the Public Comment process be used to eliminate mandatory language from the definitions for consistency with the format of other definitions in the code. The above modification does so. With one exception the changes above in this Public Comment are non-technical. In the definition for OSL the further limitation "and less than 150 times" was returned to the definition. It was inadvertently left out of the original proposal but is a part of the definition in the standard. It is a necessary part of the definition to distinguish OSL from LSL.

Final Action: AS AM AMPC ___ D

S200-09/10-PART I

2303.1.4

Proposed Change as Submitted

Proponent: Edward L. Keith, PE, APA - The Engineered Wood Association

PART I – IBC STRUCTURAL

Revise as follows:

2303.1.4 Wood structural panels. Wood structural panels, when used structurally (including those used for siding, roof and wall sheathing, subflooring, diaphragms and built-up members), shall conform to the requirements for their type in DOC PS 1 or PS 2. Each panel or member shall be identified for grade, ~~and glue type bond classification, and Performance Class~~ by the trademarks of an *approved* testing and grading agency. The Performance Class value shall be used as the "nominal panel thickness" or "panel thickness" whenever referenced in this code. Wood structural panel components shall be designed and fabricated in accordance with the applicable standards listed in Section 2306.1 and identified by the trademarks of an *approved* testing and inspection agency indicating conformance with the applicable standard. In addition, wood structural panels when permanently exposed in outdoor applications shall be of ~~exterior~~ Exterior type, except that wood structural panel roof sheathing exposed to the outdoors on the underside is permitted to be ~~interior type bonded with exterior glue, Exposure 1 type.~~

Reason: (IBC & IRC) This is a nomenclature change that reflects the newest versions of National Standards PS 1 and PS 2. Wood structural panels are required to be in conformance to DOC PS 1 and PS 2 in the code. The PS 1 and PS 2 consensus standard committees have revised both standards to include the terminologies of "bond classification" to reference glue type and "Performance Classes" to reference the thicknesses tolerance consistent with the nominal panel thicknesses in the IBC. This change proposal updates the code to the nomenclature that appears on the trademark of wood structural panels in the field in accordance with DOC PS 1 and PS 2. This is not a technical change.

Cost Impact: This will **not** impact the cost of construction.

ICCFILENAME: Keith-S4-2303.1.4

Public Hearing Results

PART I- IBC STRUCTURAL

Committee Action:

Approved as Submitted

Committee Reason: This proposal adds terminology that coordinates the IBC with the wood structure panel product standards. A public comment is in order to include a definition of the new term "Performance Class".

Assembly Action:

None

Individual Consideration Agenda

This item is on the agenda for individual consideration because a public comment was submitted.

Public Comment:

Edward L. Keith, APA, The Engineered Wood Association, requests Approval as Modified by this Public Comment.

Further modify the proposal as follows:

2303.1.4 Wood structural panels. Wood structural panels, when used structurally (including those used for siding, roof and wall sheathing, subflooring, diaphragms and built-up members), shall conform to the requirements for their type in DOC PS 1 or PS 2. Each panel or member shall be identified for grade, bond classification, and Performance Class Category by the trademarks of an *approved* testing and grading agency. The Performance Class Category value shall be used as the “nominal panel thickness” or “panel thickness” whenever referenced in this code. Wood structural panel components shall be designed and fabricated in accordance with the applicable standards listed in Section 2306.1 and identified by the trademarks of an *approved* testing and inspection agency indicating conformance with the applicable standard. In addition, wood structural panels when permanently exposed in outdoor applications shall be of Exterior type, except that wood structural panel roof sheathing exposed to the outdoors on the underside is permitted to be Exposure 1 type.

PERFORMANCE CATEGORY. A designation of wood structural panels as related to the panel performance used in Chapter 23.

Commenter's Reason: At the final ballot process, the PS1 and PS2 update committees changed editorially the term “Performance Class” to “Performance Category” in the standards. Item 1 of Part I and Item 1 of Part II above in this Public Comment make this editorial change to the proposed code change text.

Along with the recommendation for approval by the IBC and IRC Committees, a recommendation was made by one of the committee members at the Code Development Hearing that a definition for the term “Performance Class” (now “Performance Category”) be added to the IBC and IRC as the term was new to the building codes. The above definition is proposed for the IBC and IRC in accordance with that committee member's recommendation.

Final Action: AS AM AMPC_____ D

S200-09/10-PART II

IRC R503.2.1, R503.2.1.1, R602.3, R803.2.1

Proposed Change as Submitted

Proponent: Edward L. Keith, PE, APA - The Engineered Wood Association

PART II – IRC BUILDING/ENERGY

Revise as follows:

R503.2.1 Identification and grade. Wood structural panel sheathing used for structural purposes shall conform to DOC PS 1, DOC PS 2 or, when manufactured in Canada, CSA O437 or CSA O325. All panels shall be identified for grade, bond classification, and Performance Class by a grade mark of certificate or inspection issued by an approved agency. The Performance Class value shall be used as the “nominal panel thickness” or “panel thickness” whenever referenced in this code.

R503.2.1.1 Subfloor and combined subfloor underlayment. Where used as subflooring or combination subfloor underlayment, wood structural panels shall be of one of the grades specified in Table R503.2.1.1(1). When sanded plywood is used as combination subfloor underlayment, the grade, bond classification, and Performance Class shall be as specified in Table R503.2.1.1(2).

R602.3 Design and construction. Exterior walls of wood-frame construction shall be designed and constructed in accordance with the provisions of this chapter and Figures R602.3(1) and R602.3(2) or in accordance with AF&PA's NDS. Components of exterior walls shall be fastened in accordance with Tables R602.3(1) through R602.3(4). Structural wall sheathing shall be fastened directly to structural framing members. Exterior wall coverings shall be capable of resisting the wind pressures listed in Table R301.2(2) adjusted for height and exposure using Table R301.2(3). Wood structural panel sheathing used for exterior walls shall conform to DOC PS 1, DOC PS 2 or, when manufactured in Canada, CSA O437 or CSA O325. All panels shall be identified for grade, bond classification, and

Performance Class by a grade mark or certificate of inspection issued by an approved agency and shall conform to the requirements of Table R602.3(3).

R803.2.1 Identification and grade. Wood structural panels shall conform to DOC PS 1, DOC PS 2 or, when manufactured in Canada, CSA O437 or CSA O325, and shall be identified for grade, bond classification, and Performance Class by a grade mark or certificate of inspection issued by an approved agency. Wood structural panels shall comply with the grades specified in Table R503.2.1.1(1).

Reason: (IBC & IRC) This is a nomenclature change that reflects the newest versions of National Standards PS 1 and PS 2. Wood structural panels are required to be in conformance to DOC PS 1 and PS 2 in the code. The PS 1 and PS 2 consensus standard committees have revised both standards to include the terminologies of “bond classification” to reference glue type and “Performance Classes” to reference the thicknesses tolerance consistent with the nominal panel thicknesses in the IBC. This change proposal updates the code to the nomenclature that appears on the trademark of wood structural panels in the field in accordance with DOC PS 1 and PS 2. This is not a technical change.

(IRC) In Section R602.3, the description of wood structural panel was added as it shows up in Chapters 5 and 8 where wood structural panels are also specified. This was done to make the code read consistently between similar sections.

Cost Impact: This will **not** impact the cost of construction.

ICCFILENAME: Keith-S4-2303.1.4

Public Hearing Results

**PART II- IRC B/E
Committee Action:**

Approved as Submitted

Committee Reason: This change updates the code for identification requirements for wood structural panels to be consistent with the latest versions of DOC PS1 and DOC PS2. This change is consistent with the IBC.

Assembly Action:

None

Individual Consideration Agenda

This item is on the agenda for individual consideration because a public comment was submitted.

Public Comment:

Edward L. Keith, APA, The Engineered Wood Association, requests Approval as Modified by this Public Comment.

Modify the proposal as follows

Part II – IRC BUILDING/ENERGY

R503.2.1 Identification and grade. Wood structural panel sheathing used for structural purposes shall conform to DOC PS 1, DOC PS 2 or, when manufactured in Canada, CSA O437 or CSA O325. All panels shall be identified for grade, bond classification, and Performance ~~Class~~ Category by a grade mark or certificate of inspection issued by an approved agency. The Performance ~~Class~~ Category value shall be used as the “nominal panel thickness” or “panel thickness” whenever referenced in this code.

R503.2.1.1 Subfloor and combined subfloor underlayment. Where used as subflooring or combination subfloor underlayment, wood structural panels shall be of one of the grades specified in Table R503.2.1.1(1). When sanded plywood is used as combination subfloor underlayment, the grade, bond classification, and Performance ~~Class~~ Category shall be as specified in Table R503.2.1.1(2).

R602.3 Design and construction. Exterior walls of wood-frame construction shall be designed and constructed in accordance with the provisions of this chapter and Figures R602.3(1) and R602.3(2) or in accordance with AF&PA’s NDS. Components of exterior walls shall be fastened in accordance with Tables R602.3(1) through R602.3(4). Structural wall sheathing shall be fastened directly to structural framing members. Exterior wall coverings shall be capable of resisting the wind pressures listed in Table R301.2(2) adjusted for height and exposure using Table R301.2(3). Wood structural panel sheathing used for exterior walls shall conform to DOC PS 1, DOC PS 2 or, when manufactured in Canada, CSA O437 or CSA O325. All panels shall be identified for grade, bond classification, and Performance ~~Class~~ Category by a grade mark or certificate of inspection issued by an approved agency and shall conform to the requirements of Table R602.3(3).

R803.2.1 Identification and grade. Wood structural panels shall conform to DOC PS 1, DOC PS 2 or, when manufactured in Canada, CSA O437 or CSA O325, and shall be identified for grade, bond classification, and Performance ~~Class~~ Category by a grade mark or certificate of inspection issued by an approved agency. Wood structural panels shall comply with the grades specified in Table R503.2.1.1(1).

Add definition to Section R202 as follows:

PERFORMANCE CATEGORY. A designation of wood structural panels as related to the panel performance used in Chapters 4, 5, 6, and 8.

Commenter's Reason: At the final ballot process, the PS1 and PS2 update committees changed editorially the term "Performance Class" to "Performance Category" in the standards. Item 1 of Part I and Item 1 of Part II above in this Public Comment make this editorial change to the proposed code change text.

Along with the recommendation for approval by the IBC and IRC Committees, a recommendation was made by one of the committee members at the Code Development Hearing that a definition for the term "Performance Class" (now "Performance Category") be added to the IBC and IRC as the term was new to the building codes. The above definition is proposed for the IBC and IRC in accordance with that committee member's recommendation.

Final Action: AS AM AMPC _____ D

S201-09/10, Part I

2303.2, 2303.2.1, 2303.2.2, 2303.2.3

Proposed Change as Submitted

Proponent: Joe Holland and Dave Bueche, representing Hoover Treated Wood Products

PART I- IBC STRUCTURAL

1. Revise as follows:

2303.2 Fire-retardant-treated wood. ~~Fire-retardant-treated wood (FRTW) is a pressure treated any wood product which, when impregnated with chemicals by a pressure process or other means during manufacture, shall have, when tested in accordance with ASTM E 84 or UL723, FRTW shall have~~ a *listed* flame spread index of 25 or less and show no evidence of significant progressive combustion when the test is continued for an additional 20-minute period. ~~Additionally, the flame front shall not progress more than 101/2 feet (3200 mm) beyond the centerline of the burners at any time during the test.~~

2. Delete without substitution:

~~**2303.2.1 Pressure process.** For wood products impregnated with chemicals by a pressure process, the process shall be performed in closed vessels under pressures not less than 50 pounds per square inch gauge (psig) (345 kPa).~~

~~**2303.2.2 Other means during manufacture.** For wood products produced by other means during manufacture, the treatment shall be an integral part of the manufacturing process of the wood product. The treatment shall provide permanent protection to all surfaces of the wood product.~~

~~**2303.2.3 Testing.** For wood products produced by other means during manufacture, other than a pressure process, all sides of the wood product shall be tested in accordance with and produce the results required in Section 2303.2. Wood structural panels shall be permitted to test only the front and back faces.~~

(Renumber remaining sections)

Reason: Revision is more concise. Present section is wordy. In the fifty years of recognition of FRTW in the code there is no wood product meeting the requirement of FRTW where adding the fire retardant to the wood is done during manufacture. This provision creates interpretation problems in the field. Revision will improve enforcement of section. "Pressure process" and "other means during manufacturer" are no longer used; delete Sections 2303.2.1 through 2303.2.3.

Cost Impact: The code change proposal will not increase the cost of construction.

FILENAME: Holland-Bueche-S1-2303.2-RB-2-R802.1.3

Public Hearing Results

PART I- IBC STRUCTURAL

Committee Action:

Disapproved

Committee Reason: The proposal is not editorial as the reason suggests. If accepted, it would no longer allow fire-retardant treated wood products that currently comply with the code. If there are problems, they would appear to accent the need for education. Acceptability should be defined by the products performance not the means or method of manufacture.

Assembly Action:

None

Individual Consideration Agenda

This item is on the agenda for individual consideration because a public comment was submitted.

Public Comment:

Joseph Holland and Dave Bueche, representing Hoover Treated Wood Products Inc, requests Approval as Submitted.

Commenter's Reason: In the fifty years of recognition of FRTW in the code there is no wood product meeting the requirement of FRTW where adding the fire retardant to the wood is done during manufacture. This provision creates interpretation problems in the field. Revision will improve enforcement of section. "Pressure process" and "other means during manufacturer" are no longer used; delete Sections 2303.2.1 through 2303.2.3 and Section s R802.1.3.1 through R802.1.3.3.

Final Action: AS AM AMPC____ D

S201-09/10, Part II

IRC R802.1.3, R802.1.3.1, R802.1.3.2, R802.1.3.3

Proposed Change as Submitted

Proponent: Joe Holland and Dave Bueche, representing Hoover Treated Wood Products

PART II- IRC BUILDING/ENERGY

1. Revise as follows:

R802.1.3 Fire-retardant-treated wood. ~~Fire-retardant-treated wood (FRTW) is a pressure treated any wood product which, when impregnated with chemicals by a pressure process or other means during manufacture, shall have, when tested in accordance with ASTM E 84, FRTW shall have a listed flame spread index of 25 or less and show no evidence of significant progressive combustion when the test is continued for an additional 20-minute period. Additionally, the flame front shall not progress more than 10.5 feet (3200 mm) beyond the centerline of the burners at any time during the test~~

2. Delete without substitution:

~~**R802.1.3.1 Pressure process.** For wood products impregnated with chemicals by a pressure process, the process shall be performed in closed vessels under pressures not less than 50 pounds per square inch gauge (psig) (345 kPa).~~

~~**R802.1.3.2 Other means during manufacture.** For wood products produced by other means during manufacture, the treatment shall be an integral part of the manufacturing process of the wood product. The treatment shall provide permanent protection to all surfaces of the wood product.~~

~~**R802.1.3.3 Testing.** For wood products produced by other means during manufacture, other than a pressure process, all sides of the wood product shall be tested in accordance with and produce the results required in Section R802.1.3. Testing of only the front and back faces of wood structural panels shall be permitted.
(Renumber remaining sections)~~

Reason: Revision is more concise. Present section is wordy. In the fifty years of recognition of FRTW in the code there is no wood product meeting the requirement of FRTW where adding the fire retardant to the wood is done during manufacture. This provision creates interpretation problems in the field. Revision will improve enforcement of section. "Pressure process" and "other means during manufacturer" are no longer used; delete Sections R802.1.3.1 through R802.1.3.3.

Cost Impact: The code change proposal will not increase the cost of construction.

FILENAME: Holland-Bueche-S1-2303.2-RB-2-R802.1.3

Public Hearing Results

PART II- IRC B/E

Committee Action:

Disapproved

Committee Reason: The proposal would have the effect of being exclusionary. It would provide language that appears to eliminate some products in the market. This proposal would hinder development of new products.

Assembly Action:

None

Individual Consideration Agenda

This item is on the agenda for individual consideration because a public comment was submitted.

Public Comment:

Joseph Holland and Dave Bueche, representing Hoover Treated Wood Products Inc, requests Approval as Submitted

Commenter's Reason: See S201-09/10-Part I

Final Action: AS AM AMPC _____ D

S205-09/10 2304.11.6

Proposed Change as Submitted

Proponent: Homer Maiel, PE, CBO, City of San Jose, representing ICC Tri-Chapter (Peninsula, East Bay, Monterey Bay)

Revise as follows:

Section 2304.11.6 Termite protection. In geographical areas where hazard of termite damage is known to be very heavy, wood floor framing exposed to the ground in crawl spaces or unexcavated areas located within the periphery of the building foundation and exposed framing of exterior decks or balconies, shall be of durable species (termite resistant) or preservative treated in accordance with AWPA U1 for the species, product preservative and end use or provided with approved methods of termite protection.

Reason: This change intends to clarify that the wood floor framing that needs to be durable species or preservative treated wood are limited to those interior floors with exposure to soil instead of all floors in the building. In addition exposed exterior decks or balcony framing are specifically added. Other provisions address wood in contact with concrete or close to grade for all termite hazard regions.

Cost Impact: The code change proposal will not increase the cost of construction.

ICCFILENAME: MAIEL-S1-2304.11.6

Public Hearing Results

Committee Action:

Disapproved

Committee Reason: The need for this requirement for termite protection is unclear, since Section 2304.11.2.1 already covers wood within 18 inches of exposed earth.

Assembly Action:

None

Individual Consideration Agenda

This item is on the agenda for individual consideration because a public comment was submitted.

Public Comment:

Gary J. Ehrlich, PE., National Association of Home Builders (NAHB), requests Approval as Modified by this Public Comment.

Modify the proposal as follows:

Section 2304.11.6 Termite protection. In geographical areas where hazard of termite damage is known to be very heavy, wood floor framing in the locations specified in Section 2304.11.2.1 ~~exposed to the ground in crawl spaces or unexcavated areas located within the periphery of the building foundation~~ and exposed framing of exterior decks or balconies, shall be of durable species (termite resistant) or preservative treated in accordance with AWPA U1 for the species, product preservative and end use or provided with approved methods of termite protection.

Commenter's Reason: The purpose of this public comment is to further clarify the requirements for termite protection of floor framing. We agree with the proponents' intent that only those interior floors with direct exposure to soil need termite protection. The Structural Committee, in disapproving the proposal, believed that Section 2304.11.2.1 already covered the proponent's intent. However, the charging language of Section 2304.11.2 does not explicitly mention termite resistance. Thus, to clearly make the connection between Section 2304.11.6 and the specific requirements for exposure to ground, a direct reference to Section 2304.11.2.1 needs to be provided in Section 2304.11.6.

Final Action: AS AM AMPC____ D

S207-09/10-PART I

2302.1, 2303.1, 2303.1.12 (New), 2304.13 (New), CHAPTER 35;

Proposed Change as Submitted

Proponent: John Woestman, The Kellen Company representing the Composite Lumber Manufacturers Association (CLMA)

PART I – IBC STRUCTURAL

1. Add new definition as follows:

WOOD PLASTIC COMPOSITE. A composite material made primarily from wood or cellulose-based materials, and plastic.

2. Revise as follows:

2303.1 General. Structural sawn lumber; end-jointed lumber; prefabricated wood I-joists; structural glued laminated timber; wood structural panels, fiberboard sheathing (when used structurally); hardboard siding (when used structurally); particleboard; preservative-treated wood; structural log members; structural composite lumber; round timber poles and piles; fire-retardant-treated wood; hardwood plywood; wood trusses; wood plastic composite exterior deck components; joist hangers; nails; and staples shall conform to the applicable provisions of this section.

3. Add new text as follows:

2303.1.12 Wood plastic composite exterior deck, railing, and stairway components. Structural capacities for exterior wood plastic composite deck boards, stair treads, handrails and guardrail systems shall be determined in accordance with ASTM D 7032.

2304.13 Wood plastic composite exterior deck, railing, and stairway components. Exterior wood plastic composite deck boards, deck boards used as stair treads, handrails and guardrail systems shall meet the applicable requirements of ASTM D 7032, and bear a label indicating the required performance levels and demonstrating compliance with ASTM D 7032.

4. Add new standard to Chapter 35 as follows:

ASTM

D 7032-08 Standard Specification for Establishing Performance Ratings For Wood-Plastic Composite Deck Boards and Guardrail Systems (Guards or Handrails)

5. Add new text as follows:

2304.13.1 Labeling. Labels for deck boards and stair treads shall include the allowable maximum load and span. Labels for handrails and guardrail systems shall indicate the allowable maximum span.

6. Add new text as follows:

2304.13.2 Installation. Wood plastic composite deck components shall be installed in accordance with the manufacturer's instructions.

Reason:

(Part I, items 1-4) The IBC is currently silent regarding requirements for wood plastic composite exterior deck components. The Composite Lumber Manufacturers Association (CLMA) seeks to make it easier for code officials to enforce the IBC and to make it easier for deck builders to comply with the code by incorporating requirements for wood plastic composite decking into the IBC.

This code change proposes to include requirements for wood plastic composite exterior deck components in Chapter 23 of the IBC, which is the most appropriate chapter of the IBC for these products. Section 2301.2 refers to elements or systems "constructed partially or wholly of wood or wood-based products". No other IBC chapter incorporates wood-based products of this type.

Wood plastic composite exterior deck components are constructed partially of wood-based material (as are particleboard and composite panels; included in Chapter 23), and partially of resin bonded by heat and pressure (as are several materials included in Chapter 23, such as particleboard). CLMA reviewed Chapter 26, Plastic, but concluded that wood plastic composite exterior deck components are much more closely aligned with the methods of distribution and application to the materials included in Chapter 23 than those in Chapter 26. Moreover, the ASTM standard governing wood plastic composite decking (ASTM D 7032) has been developed by and continues to be maintained by the ASTM D7 committee on wood. For these reasons, this proposal includes revisions to Chapter 23.

This CLMA proposal complements language in the 2009 IRC which defines "wood plastic composite" and requires wood plastic composite deck boards, stair treads, handrails and guardrail systems to bear a label indicating the required performance levels and demonstrating compliance to ASTM D 7032. This labeling requirement, by definition of "label" in the IBC, includes 3rd-party certification and ongoing quality assurance and will help to assure the code official that wood-plastic composite decking will meet the performance provisions in the IBC.

Complying with ASTM D 7032 verifies the wood plastic composite materials are appropriate for use as deck components and includes deck-related performance evaluations such as flexural tests, ultraviolet resistance tests, freeze-thaw resistance tests, bio-deterioration tests, fire performance tests, creep recovery tests, mechanical fastener holding tests, and slip resistance tests. The standard also includes consideration of the effects of temperature and moisture, concentrated loads, and fire propagation tests.

This code change for the IBC will make it faster and easier to verify that a deck constructed of wood plastic composite material complies with the code.

(Part I, item 5) This item adds a new subject matter in 2304.13.1. This new requirement specifies that the load and span information is required on the labels.

This item will make it faster and easier to verify that a deck constructed of wood plastic composite material complies with the code. The wood plastic composite deck boards and stair treads are to have a label indicating the span rating (i.e. 100 lbs/ft² at 16" O.C.). Handrails and guardrail systems will be similarly labeled. The load and span information will improve the ability to verify compliance to the code.

(Part I, item 6) This item adds a new subject matter in 2304.13.2 which requires that wood plastic composite deck components be installed per the manufacturer's instructions.

As with most engineered building components, wood plastic composite deck components should be required to be installed per the manufacturer's instructions. It's important that wood plastic composite deck components be installed as intended by the manufacturer.

Cost Impact: The code change proposal will not increase the cost of construction.

Analysis: A review of the standard(s) proposed for inclusion in the code, ASTM D7032-08, for compliance with ICC criteria for referenced standards given in Section 3.6 of Council Policy #CP 28 will be posted on the ICC website on or before September 24, 2009.

ICCFILENAME: WOESTMAN-S7-2304.13.2

Public Hearing Results

Note: The following analysis was not in the Code Change monograph but was published on the ICC website at <http://www.iccsafe.org/cs/codes/Documents/2009-10cycle/ProposedChanges/Standards-Analysis.pdf> :

Analysis: Review of proposed new standard ASTM D 7032 indicated that, in the opinion of ICC Staff, the standard complies with ICC standards criteria.

PART I- IBC STRUCTURAL

Committee Action:

Disapproved

Committee Reason: Wood plastic composite materials are currently qualified by evaluation reports and including them in the code is not appropriate at this time. It is important to be able to verify design capacities. The proposed term, structural capacities, may not correlate with the proposed reference standard.

Assembly Action:

None

Individual Consideration Agenda

This item is on the agenda for individual consideration because a public comment was submitted.

Public Comment:

John Woestman, Kellen Company, representing Composite Lumber Manufacturer's Association, requests Approval as Modified by this Public Comment.

Replace proposal as follows:

CHAPTER 35 COMPOSITES

SECTION 3501 GENERAL

3501.1 Scope. These provisions shall govern the materials, design, application, construction and installation of composite materials and products.

SECTION 3502 DEFINITIONS

3502.1 General. The following words and terms shall, for the purposes of this chapter have the meanings shown herein.

WOOD PLASTIC COMPOSITE. A composite material made primarily from wood or cellulose-based materials, and plastic.

SECTION 3503 WOOD PLASTIC COMPOSITE EXTERIOR MATERIALS AND PRODUCTS

3503.1 General. The provisions of this section shall govern the requirements and uses of wood plastic composite materials and products for exterior decks, balconies, and porches of buildings and structures.

3503.1.1 Wood plastic composite exterior deck boards, stair treads, handrails, and guardrail systems. Exterior deck boards, stair treads, handrails, and guardrail systems of wood plastic composite shall comply with this section.

3503.1.1.1 Minimum standards and quality. Exterior wood plastic composite deck boards, stair treads, and handrails and guardrail systems shall comply with ASTM D 7032.

3503.1.1.2 Structural. The allowable load and maximum allowable span for exterior wood plastic composite deck boards and stair treads shall be determined in accordance with ASTM D 7032. Testing of handrails and guardrail systems to demonstrate compliance to the structural performance requirements of this code shall be in accordance with ASTM D7032.

3503.1.1.3 Labeling. Deck boards and stair treads shall bear a label that indicates compliance to ASTM D 7032 and includes the allowable load and maximum allowable span. Handrails and guardrail systems or their packaging shall bear a label that indicates compliance to ASTM D 7032 and includes the maximum allowable span.

3503.1.1.4 Installation. Wood plastic composite deck components shall be installed in accordance with the manufacturer's instructions.

Add standard to Chapter 356 as follows:

ASTM

D 7032-08 Standard Specification for Establishing Performance Ratings For Wood-Plastic Composite Deck Boards and Guardrail Systems (Guards or Handrails)

(Renumber existing Chapter 35 Reference Standards)

Commenter's Reason: The proponent, the Composite Lumber Manufacturers Association (CLMA), proposed creating a new chapter in the IBC for composite building products as a floor amendment at the Baltimore committee hearings in Oct. 2009. The committee chair ruled the floor amendment "in order." This public comment follows that ruling and proposes to create a new chapter in the IBC for composite building products. This public comment also addresses testimony and committee concerns in the text of the proposal or in the Reason statements. This public comment replaces the original S207 Part 1 proposal.

Currently, the IBC is silent regarding specific requirements for certain composite building materials. Proposals S207 Part 1 (this proposal) and FS189 (by AF&PA) both sought to introduce into the IBC requirements for a specific type of composite building material, wood plastic composite (WPC), used as exterior deck boards, stair treads, handrails and guardrail systems.

Discussion and debate before and during the committee hearings in Baltimore resulted in the conclusion that, rather than place WPCs in the wood chapter of the IBC (Chapter 23) or in the plastics chapter (Chapter 26), a logical location for this material is in a new chapter titled "Composites." Looking to the future, this new chapter creates a logical location in the IBC for other composites that may be utilized in building construction but fall outside the scopes of Chapter 23 and Chapter 26.

This proposal introduces a definition of wood plastic composite and creates a section for exterior materials and products made from this specific material. Then the proposal limits the scope of the requirements to materials and products for exterior decks, balconies, and porches. Finally, the proposal introduces specific requirements for exterior wood plastic composite deck boards, stair treads, handrails, and guardrail systems.

With this proposal, CLMA seeks to introduce mandatory requirements in the IBC for exterior wood plastic composite deck components while making it easier for builders to comply with the code and for building officials to enforce their code.

Including the labeling requirement in this proposal brings WPCs within the requirements of the definition of "label" in Chapter 2 of the IBC, thus requiring 3rd party certification of these WPCs and ongoing quality assurance. This requirement helps to assure building officials that wood plastic composite decking and guards will meet the performance requirements of the IBC.

As with most engineered building components, wood plastic composite deck components should be required to be installed per the manufacturer's instructions.

Addressing the published committee reasons for disapproval:

Committee reason for disapproval: "Wood plastic composite deck boards and guardrail systems are currently qualified by evaluation reports and including them into the Code is not appropriate at this time."

Proponent response: This proposal adds into the IBC sufficient explicit requirements for these specific products; therefore, no longer requiring them to be qualified by evaluation reports. The mandatory requirements of this proposal – testing and compliance to ASTM D7032, labeling, and installation – are based on and complement existing requirements in the code.

Committee reason for disapproval: "It is important to be able to verify design capabilities."

Proponent response: WPC deck boards, stair treads, and handrail and guardrail systems are engineered products.

This proposal requires wood plastic composite deck boards, stair treads, handrails and guardrail systems to meet the requirements of ASTM D7032, a standard developed specifically for demonstrating code compliance of WPC exterior deck components. Meeting the requirements of ASTM D7032 verifies the engineered WPC products are appropriate for use as exterior deck components. ASTM D7032 includes deck-related performance evaluations and performance requirements such as flexural tests, bio-degradation tests, fire performance tests, creep recovery tests, mechanical fastener holding tests, and slip resistance tests. The standard also includes consideration of the effects of temperature, moisture, concentrated loads, freeze-thaw resistance tests, UV resistance, and duration of load on WPC deck boards, stair treads, and handrail and guardrail systems.

The design capacity of each WPC deck board, stair tread, handrail, and guardrail system is tested and evaluated according to product specification ASTM D7032. The testing required in D7032 addresses IBC requirements for deck boards, stair treads, handrails, and guardrail systems.

The result of these tests determines an allowable load and span rating for deck boards and a stringer spacing for stair treads. Product labels will show verification of compliance with ASTM D 7032 and provide the appropriate performance information. For example, deck board labels would identify the allowable load and span (e.g., 100 psf load on a 16" span would be expressed as "16/100"). For stair treads, ASTM D7032 requires load and span testing at higher loads (300 psf and 750 lb concentrated load). This concentrated load test for WPC stair treads is 2.5 times what's required in the IBC in Table 1607.1, Footnote f.

Guardrail systems, per ASTM D7032, are required to be subjected to and pass the in-fill load test, the uniform load test, and the concentrated load test at 2.5 times the loads required by the IBC (in Sections 1607.7.1.2; 1607.7.1; and 1607.7.1.1 respectively) with the guardrail system constructed according to the manufacturer's instructions. These tests evaluate the strength and stiffness of all components and their connections.

For designers, specifiers, builders, and for code enforcement, the maximum post spacing (span) for guardrail systems is required to be on the label, as is verifying compliance to ASTM D7032. And, of course, guardrail systems for projects constructed under the IBC must meet the requirements of Section 1012 and 1013.

Assuming WPC deck boards, stair treads, and guardrail systems are selected, specified, and installed according to the manufacturer's instructions – and the manufacturer confirms compliance to ASTM D7032 in their literature and on the product label – designing exterior deck projects which use WPC components is quite straightforward: 1) Select WPC deck boards that meet or exceed the required load (per IBC Table 1607.1) at the desired span of the deck's joists. 2) Plan for stair stringers no farther apart than the maximum allowable span for the desired WPC stair treads. 3) Select a WPC guardrail system that meets the minimum height requirements for the project (i.e. 42" for the IBC) and plan for guardrail supports (posts) no further apart than the maximum spacing (span) allowed by the guardrail system's manufacturer.

CLMA recommends approval of S207 Part 1, as modified by this public comment.

Final Action: AS AM AMPC _____ D

S207-09/10-PART II IRC R317.4.1 (New)

Proposed Change as Submitted

Proponent: John Woestman, The Kellen Company representing the Composite Lumber Manufacturers Association

PART II – IRC BUILDING/ENERGY

1. Add new text as follows:

R317.4.1 Labeling. Labels for deck boards and stair treads shall include the allowable maximum load and span. Labels for handrails and guardrail systems shall indicate the allowable maximum span.

2. Revise as follows:

R317.4.1 R317.4.2 Installation. Wood/plastic composites shall be installed in accordance with the manufacturer's instructions.

Reason: (Part II, IRC) This CLMA proposal complements language proposed for IBC (see Part I, item 5).

This code change for the IRC will make it faster and easier to verify that a deck constructed of wood plastic composite material complies with the code. The wood plastic composite deck boards and stair treads are to have a label indicating the span rating (i.e. 100 lbs/ft² at 16" O.C.) in addition to confirming compliance to ASTM D7032. Handrails and guardrail systems will be similarly labeled with their span rating (distance between support posts).

Cost Impact: The code change proposal will not increase the cost of construction.

ICCFILENAME: WOESTMAN-S7-2304.13.2

Public Hearing Results

**PART II- IRC B/E
Committee Action:**

Disapproved

Committee Reason: The labeling requirements are unclear and present a problem for inspectors after installation. There are no directions for how to label and the location of the label. The labeling should be similar to sheathing that allows the inspector to visibly, easily and readily verify that the proper material is installed.

Assembly Action:

None

Individual Consideration Agenda

This item is on the agenda for individual consideration because public comments were submitted.

Public Comment 1:

Rick Davidson, representing self, requests Approval as Submitted.

Commenter's Reason: Because of the different installation requirements for composite decking, especially when used for stair treads, having this information on the label may eliminate the need for field inspection staff to read through research reports (that may not always be available in the field) in order to approve an installation. It seems that having this additional information would make life easier for both the installer and the field inspector and it should be approved.

Public Comment 2:

John Woestman, Kellen Company, representing Composite Lumber Manufacturer's Association (CLMA), requests Approval as Modified by this Public Comment.

Modify the proposal as follows:

R317.4.1 Labeling. ~~Labels for deck boards and stair treads shall include the allowable maximum load and span. Labels for handrails and guardrail systems shall indicate the allowable maximum span.~~ Deck boards and stair treads shall bear a label that indicates compliance to ASTM D 7032 and includes the allowable load and maximum allowable span. Handrails and guardrail systems or their packaging shall bear a label that indicates compliance to ASTM D 7032 and includes the maximum allowable span.

R317.4.2 Installation. Wood/plastic composites shall be installed in accordance with the manufacturer's instructions.

Commenter's Reason: This proposal clarifies mandatory labeling requirements for wood/plastic composites currently in this section of the IRC.

Each deck board and stair tread, similar to pressure-preservative treated wood, is required to have a label. The required label would be applied on an end or on a face (side) of each board. Product labels will show verification of compliance with ASTM D 7032 and provide the appropriate performance information. For example, deck board labels would identify the allowable load and span (e.g., 40 psf load on a 16" span would be expressed as "16/40").

Handrails and guardrail systems, which are more often supplied as "kits" in packages, require labels on the items or on the packaging. For ease of code enforcement, the maximum span (maximum vertical post spacing) is required to be on the label, as is verifying compliance to ASTM D7032.

In summary, for ease of code enforcement, this code change clarifies / adds items required on the labels to be placed on wood/plastic composite deck boards, stair treads, handrails, and guardrail systems. CLMA recommends approval of S207 Part 2, as modified by this public comment.

Final Action: AS AM AMPC____ D

S211-09/10

2308.3.2, 2308.3.2.1 (New), 2308.3.2.2 (New), 2308.12.6

Proposed Change as Submitted

Proponent: Robert Rice, Grants Pass, representing Josephine County Building Safety and Southern Oregon Chapter International Code Council.

Revise as follows:

2308.3.2 Braced wall line connections. Wind and seismic lateral forces shall be transferred from the ~~roof roofs~~ and ~~floor floors~~ diaphragms to braced wall lines and from the braced wall lines in upper stories to the braced wall lines in the story below in accordance with ~~this section~~ Sections 2308.3.2.1 and 2308.3.2.2.

2308.3.2.1 Bottom plate connection. Braced wall line bottom plates shall be connected to joists or full-depth blocking below in accordance with Table 2304.9.1, Item 6, or to foundations in accordance with Section 2308.3.3.

2308.3.2.2 Top plate connection. Where joists or rafters are used, braced wall line top plates shall be fastened to joists, rafters or full-depth blocking above in accordance with Table 2304.9.1, Items 11, 12, 15 or 19 as applicable based on the orientation of the joists or rafters to the braced wall line. ~~Braced wall line bottom plates shall be connected to joists or blocking below in accordance with Table 2304.9.1, Item 6, or to foundations in accordance with Section 2308.3.3.~~ Blocking shall be a minimum of 2 inches (51 mm) nominal in thickness and equal to the depth of the joist or rafter at the wall line and shall be fastened to the braced wall line top plate as specified in Table 2304.9.1, Item 11.

Exception: Blocking at rafters need not be full depth when there are no braced wall lines above but shall extend to within 2 inches (51 mm) from the sheathing above.

At exterior gable end walls braced wall panel sheathing in the top story shall be extended and fastened to roof framing where the spacing between parallel exterior braced wall lines is greater than 50 feet (15240 mm).

Exception: Where roof trusses are used and are installed perpendicular to an exterior braced wall line, lateral forces shall be transferred from the roof diaphragm to the braced wall by blocking of the ends of the trusses or by other *approved* methods providing equivalent lateral force transfer. Blocking shall be minimum 2 inch (51 mm) nominal thickness and equal to the depth of the truss at the wall line and shall be fastened to the braced wall line top plate as specified in Table 2304.9.1, Item 11

2308.12.6 Irregular structures. *Conventional light-frame construction* shall not be used in irregular portions of structures in *Seismic Design Category D or E*. Such irregular portions of structures shall be designed to resist the forces specified in Chapter 16 to the extent such irregular features affect the performance of the conventional framing system. A portion of a structure shall be considered to be irregular where one or more of the conditions described in Items 1 through 6 below are present.

1. Where exterior braced wall panels are not in one plane vertically from the foundation to the uppermost story in which they are required, the structure shall be considered to be irregular [see Figure 2308.12.6(1)].

Exception: Floors with cantilevers or setbacks not exceeding four times the nominal depth of the floor joists [see Figure 2308.12.6(2)] are permitted to support braced wall panels provided:

1. Floor joists are 2 inches by 10 inches (51mm by 254 mm) or larger and spaced not more than 16 inches (406 mm) o.c.
2. The ratio of the back span to the cantilever is at least 2:1.
3. Floor joists at ends of braced wall panels are doubled.
4. A continuous rim joist is connected to the ends of cantilevered joists. The rim joist is less than 0.058 inch (1.47 mm) (16 galvanized gage) and 1 1/2 inches (38 mm) wide fastened with six 16d common nails on each side. The metal tie shall have a minimum yield of 33,000 psi (227 MPa).
5. Joists at setbacks or the end of cantilevered joists shall not carry gravity loads from more than a single story having uniform wall and roof loads, nor carry the reactions from headers having a span of 8 feet (2438 mm) or more.

2. Where a section of floor or roof is not laterally supported by braced wall lines on all edges and connected in accordance with Section 2308.3.2, the structure shall be considered to be irregular [see Figure 2308.12.6(3)].

Exception: Portions of roofs or floors that do not support braced wall panels above are permitted to extend up to 6 feet (1829 mm) beyond a braced wall line [see Figure 2308.12.6(4)] provided that the framing members are connected to the braced wall line below in accordance with Section 2308.3.2.

3. Where the end of a required braced wall panel extends more than 1 foot (305 mm) over an opening in the wall below, the structure shall be considered to be irregular. This requirement is applicable to braced wall panels offset in plane and to braced wall panels offset out of plane as permitted by the exception to Item 1 above in this section [see Figure 2308.12.6(5)].

Exception: Braced wall panels are permitted to extend over an opening not more than 8 feet (2438 mm) in width where the header is a 4-inch by 12-inch (102 mm by 305 mm) or larger member.

4. Where portions of a floor level are vertically offset such that the framing members on either side of the offset cannot be lapped or tied together in an *approved* manner, the structure shall be considered to be irregular [see Figure 2308.12.6(6)].

Exception: Framing supported directly by foundations need not be lapped or tied directly together.

5. Where braced wall lines are not perpendicular to each other, the structure shall be considered to be irregular [see Figure 2308.12.6(7)].
6. Where openings in floor and roof diaphragms having a maximum dimension greater than 50 percent of the distance between lines of bracing or an area greater than 25 percent of the area between orthogonal pairs of braced wall lines are present, the structure shall be considered to be irregular [see Figure 2308.12.6(8)].

Reason: This code section addresses the connection of braced wall lines to framing above and below to transfer lateral (wind and seismic) forces into the roof and floor diaphragms. This proposal does not add any new requirements. First, in Section 2308.3.2, this proposal separates the top plate connection requirements from the bottom plate connections for clarity. Secondly, in section 2308.12.6, a reference is added to point to the connection requirements in 2308.3.2.

Purpose: As currently written, the text of the code combines top plate and bottom plate connections in the same paragraph. Top plate connection requirements at roofs and ceilings are typically different than connections to floors above. At roofs, rafters or trusses are used and pose different challenges as opposed to flat floor joists. This proposal is intended to make the section read more clearly as well as arrange it to work with another proposal revising this section that will provide prescriptive solutions for connections at the top plate to the roof diaphragm when full-depth, solid blocking will not work or is impractical.

Cost Impact: The code change proposal will not increase the cost of construction.

ICCFILENAME: RICE-S1-2308.3.2

Public Hearing Results

Committee Action:

Approved as Modified

Modify the proposal as follows:

2308.3.2.2 Top plate connection. Where joists and/or rafters are used, braced wall line top plates shall be fastened to joists, rafters, rimboards or ~~full depth~~ blocking above in accordance with Table 2304.9.1, Items 11, 12, 15 or 19 as applicable based on the orientation of the joists or rafters to the braced wall line. Blocking at joists with walls above shall be a minimum of 2 inches (51 mm) nominal in thickness and shall be equal to the depth of the joist or rafter at the braced wall line and shall be fastened to the braced wall line top plate as specified in Table 2304.9.1, Item 11. **Exception:** Blocking at rafters need not be full depth ~~when there are no braced wall lines above~~ but shall extend to within 2 inches (51 mm) from the roof sheathing above. Blocking shall be a minimum of 2 inches (51 mm) nominal in thickness and shall be fastened to the braced wall line top plate as specified in Table 2304.9.1, Item 11.

At exterior gable end walls braced wall panel sheathing in the top story shall be extended and fastened to roof framing where the spacing between parallel exterior braced wall lines is greater than 50 feet (15240 mm).

Where roof trusses are used and are installed perpendicular to an exterior braced wall line, lateral forces shall be transferred from the roof diaphragm to the braced wall by blocking of the ends of the trusses or by other *approved* methods providing equivalent lateral force transfer. Blocking shall be minimum 2 inch (51 mm) nominal thickness and equal to the depth of the truss at the wall line and shall be fastened to the braced wall line top plate as specified in Table 2304.9.1, Item 11

(Portions of proposal not shown are unchanged)

Committee Reason: This code change clarifies what's required for braced wall line connections by breaking out the requirements for top plate and bottom plate. This is often difficult to accommodate while addressing energy code and ventilation issues. There are unresolved issues with the 2 inch gap allowed at rafters, but it is considered acceptable. The modification cleans up the proposed wording and provides an acceptable starting point for getting these clarifications into the code.

Assembly Action:

None

Individual Consideration Agenda

This item is on the agenda for individual consideration because public comments were submitted.

Public Comment 1:

Gary J. Ehrlich, PE National Association of Home Builders, requests Approval as Modified by this Public Comment.

Further modify the proposal as follows:

2308.3.2.2 Top plate connection. Where joists and/or rafters are used, braced wall line top plates shall be fastened to joists, rafters, rimboards or blocking above in accordance with Table 2304.9.1, Items 11, 12, 15 or 19 as applicable based on the orientation of the joists or rafters to the braced wall line. Blocking at joists with walls above shall be equal to the depth of the joist at the braced wall line. Blocking at rafters need not be full depth but shall extend to within 2 inches (51 mm) from the roof sheathing above. Blocking shall be a minimum of 2 inches (51 mm) nominal in thickness and shall be fastened to the braced wall line top plate as specified in Table 2304.9.1, Item 11. Notching or drilling of holes in blocking in accordance with the requirements of Section 2308.8.2 or Section 2308.10.4.2 shall be permitted.

At exterior gable end walls braced wall panel sheathing in the top *story* shall be extended and fastened to roof framing where the spacing between parallel exterior braced wall lines is greater than 50 feet (15240 mm).

Where roof trusses are used and are installed perpendicular to an exterior braced wall line, lateral forces shall be transferred from the roof diaphragm to the braced wall by blocking of the ends of the trusses or by other *approved* methods providing equivalent lateral force transfer. Blocking shall be minimum 2 inch (51 mm) nominal thickness and equal to the depth of the truss at the wall line and shall be fastened to the braced wall line top plate as specified in Table 2304.9.1, Item 11. Notching or drilling of holes in blocking in accordance with the requirements of Section 2308.8.2 or Section 2308.10.4.2 shall be permitted.

(Portions of proposal not shown are unchanged)

Commenter's Reason: The purpose of this public comment is to amend the blocking provisions approved at the Public Hearings in Baltimore. Increased requirements for ventilation of attic and roof spaces are being introduced in the energy codes. These provisions conflict with requirements for solid full-depth blocking, necessitating engineered solutions. Some of these engineered details are quite complex, often involving double rows of blocking. Often, "pre-engineered" blocking with pre-drilled holes is provided. The language proposed here would permit the application of the prescriptive drilling and notching requirements currently allowed for joists and rafters to be used for blocking. A similar change was approved last cycle for Section R802.7.1 of the IRC.

Public Comment 2:

Larry Wainright, Qualtim, Inc, representing Structural Building Components Association, (SBCA), requests Approval as Modified by this Public Comment.

Further modify the proposal as follows:

2308.3.2.2 Top plate connection. Where joists and/or rafters are used, braced wall line top plates shall be fastened to joists, rafters, rimboards or blocking above in accordance with Table 2304.9.1, Items 11, 12, 15 or 19 as applicable based on the orientation of the joists or rafters to the braced wall line. Blocking at joists with walls above shall be equal to the depth of the joist at the braced wall line. Blocking at rafters need not be full depth but shall extend to within 2 inches (51 mm) from the roof sheathing above. Blocking shall be a minimum of 2 inches (51 mm) nominal in thickness and shall be fastened to the braced wall line top plate as specified in Table 2304.9.1, Item 11.

At exterior gable end walls braced wall panel sheathing in the top *story* shall be extended and fastened to roof framing where the spacing between parallel exterior braced wall lines is greater than 50 feet (15240 mm).

Where roof trusses are used and are installed perpendicular to an exterior braced wall line, lateral forces shall be transferred from the roof diaphragm to the braced wall by blocking of the ends of the trusses or by other *approved* methods providing equivalent lateral force transfer. Blocking shall be minimum 2 inch (51 mm) nominal thickness and ~~equal to the depth of the truss at the wall line shall extend to within 2 inches (51 mm) from the roof sheathing above~~ and shall be fastened to the braced wall line top plate as specified in Table 2304.9.1, Item 11.

(Portions of proposal not shown are unchanged)

Commenter's Reason: The purpose of this change is to maintain consistency between differing products used in the same application. The modification that was approved at the code development hearings allow the blocking between rafters to extend to within 2" of the roof sheathing to allow for proper ventilation. This provision was inadvertently left out of the same provision for roof trusses.

Public Comment 3:

Steven Winkel, FAIA, PE, and Kelly Cobeen, PE, SE, representing the Federal Emergency Management Agency/Building Seismic Safety Council Code Resource Support Committee (FEMA/BSSC CRSC); Alan Robinson, representing the Structural Engineers Association of California, request Approval as Modified by this Public Comment.

Further modify the proposal as follows:

2308.3.2.2 Top plate connection. Where joists and/or rafters are used, braced wall line top plates shall be fastened over the full length of the braced wall line to joists, rafters, rimboards or blocking above in accordance with Table 2304.9.1, Items 11, 12, 15 or 19 as applicable based on the orientation of the joists or rafters to the braced wall line. Blocking at joists with walls above shall be equal to the depth of the joist at the braced wall line. Blocking at rafters need not be full depth but shall extend to within 2 inches (51 mm) from the roof sheathing above. Blocking shall be a minimum of 2 inches (51 mm) nominal in thickness and shall be fastened to the braced wall line top plate as specified in Table 2304.9.1, Item 11.

At exterior gable end walls braced wall panel sheathing in the top story shall be extended and fastened to roof framing where the spacing between parallel exterior braced wall lines is greater than 50 feet (15240 mm).

Where roof trusses are used and are installed perpendicular to an exterior braced wall line, lateral forces shall be transferred from the roof diaphragm to the braced wall over the full length of the braced wall line by blocking of the ends of the trusses or by other *approved* methods providing equivalent lateral force transfer. Blocking shall be minimum 2 inch (51 mm) nominal thickness and equal to the depth of the truss at the wall line and shall be fastened to the braced wall line top plate as specified in Table 2304.9.1, Item 11.

(Portions of proposal not shown are unchanged)

Commenter's Reason: This public comment clarifies the required extent of shear transfer connections for braced wall panels. A related public comment to RB 109 clarifies similar construction in the IRC. The purpose of these connections is to transfer seismic and wind loads from the roof to the wall below or from wall above to wall below. This code change as approved by the IBC structural committee permits the addition of a 2-inch gap between the top of blocking and the roof sheathing, which reduces the strength and capacity of the roof system and the shear transfer connection. There is not adequate research available to demonstrate that the reduced strength and stiffness are sufficient when blocking is limited to the length of the braced wall panel. Extension of the blocking over the full braced wall line length replicates common existing construction that has a history of adequate performance.

Final Action: AS AM AMPC _____ D

S212-09/10

2308.3.2, Figure 2308.3.2(1) (New), Figure 2308.3.2(2) (New)

Proposed Change as Submitted

Proponent: Robert Rice, Grants Pass, OR, representing Josephine County Building Safety and Southern Oregon Chapter International Code Council.

Revise as follows:

2308.3.2 Braced wall line connections. Wind and seismic lateral forces shall be transferred from the roofs and floors to braced wall lines and from the braced wall lines in upper stories to the braced wall lines in the story below in accordance with is section.

Braced wall line top plates shall be fastened to joists, rafters or full-depth blocking above in accordance with Table 2304.9.1, Items 11, 12, 15 or 19 as applicable based on the orientation of the joists or rafters to the braced wall line. Braced wall line bottom plates shall be connected to joists or blocking below in accordance with Table 2304.9.1, Item 6, or to foundations in accordance with Section 2308.3.3. At exterior gable end walls, braced wall panel sheathing in the top story shall be extended and fastened to roof framing where the spacing between parallel exterior braced wall lines is greater than 50 feet (15 240 mm).

Exception: Where roof trusses are used and are installed perpendicular to an exterior braced wall line, lateral forces shall be transferred from the roof diaphragm to the braced wall by blocking of the ends of the trusses or by other approved methods providing equivalent lateral force transfer. Blocking shall be a minimum of 2 inches (51 mm) nominal in thickness and equal to the depth of the truss at the wall line and shall be fastened to the braced wall line top plate as specified in Table 2304.9.1, Item 11.

Exceptions:

1. For buildings that are classified as Seismic Design Category A, B or C and the basic wind speed is less than 100 mph (45 m/s) where the framing members are perpendicular to the wall line below and the distance from the top plate to the sheathing above is less than 9 1/4 inches (235 mm) solid blocking need not be provided when the perpendicular framing members or a parallel member such as a continuous rim joist or header is attached to the wall line in accordance with Table 2304.9.1.
2. Where the roof sheathing is greater than 9-1/4 inches (235 mm) above the top plate solid blocking is not required when the framing members are connected in accordance with one of the following methods:
 - 2.1 In accordance with Figure 2308.3.2 (1)
 - 2.2 In accordance with Figure 2308.3.2 (2)
 - 2.3 With full height engineered blocking panels designed for values listed in AF&PA WFCM.
 - 2.4 Designed in accordance with accepted engineering methods.

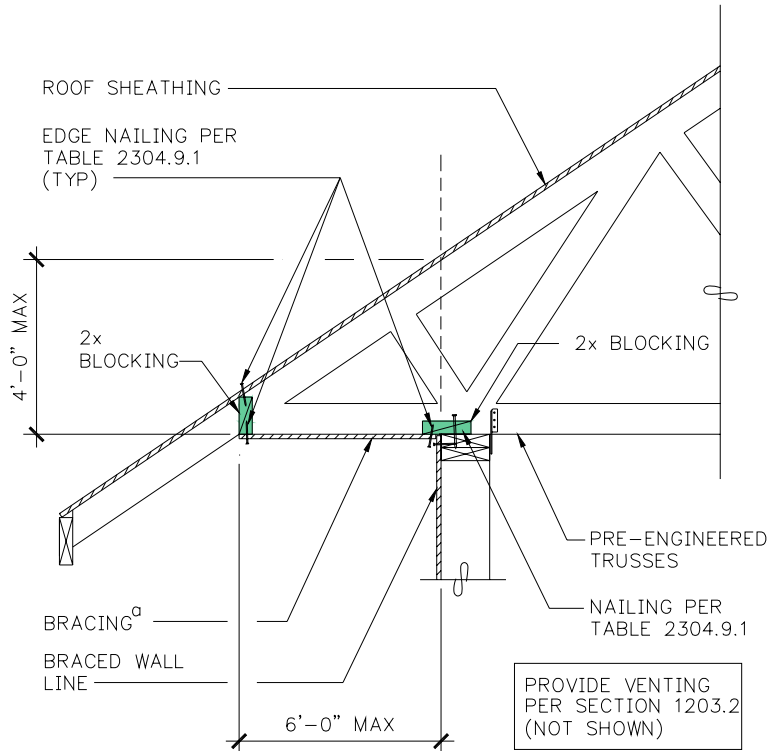

a. Methods of bracing shall be as described in Section 2308.9.3 method 2, 3, 4, 6, 7 or 8

(A) SECTION

For SI: 1 inch = 25.4 mm

FIGURE 2308.3.2 (1)
BRACED WALL PANEL TOP PLATE CONNECTION

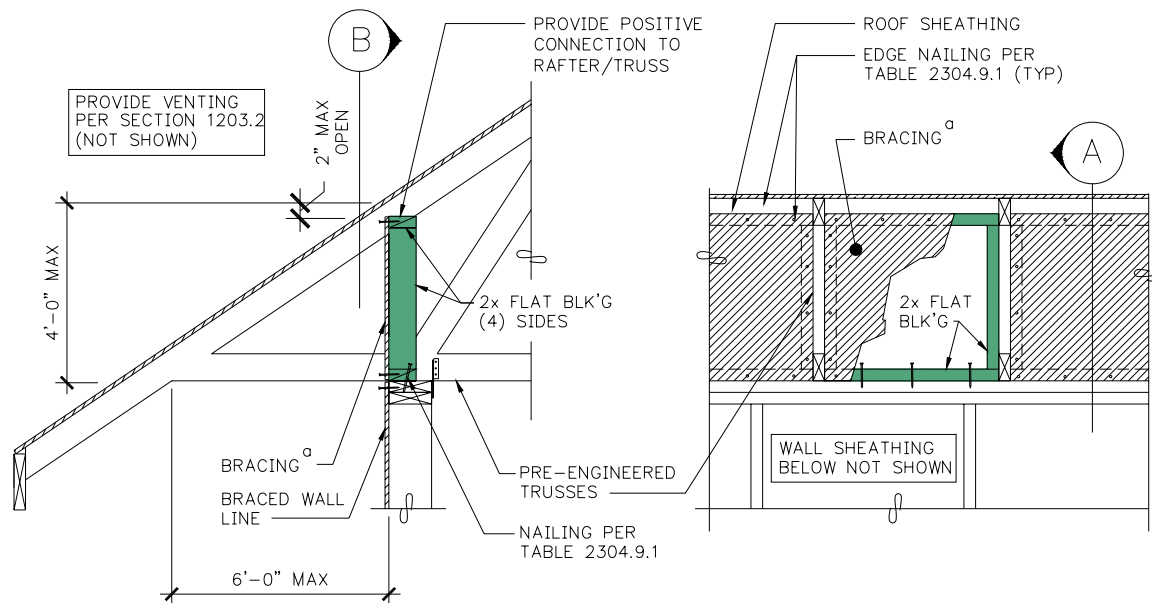

a. Methods of bracing shall be as described in Section 2308.9.3 methods 2, 3, 4, 6, 7 or 8

(A) SECTION (B) ELEVATION

For SI: 1 inch = 25.4 mm

FIGURE 2308.3.2 (2) BRACED WALL PANEL TOP PLATE CONNECTION

Reason: The 2006 IBC had fairly clear wording that the diaphragms need to be connected to the braced wall lines. With the approval of proposal 2008/2009 S224 the 2009 language was modified to make the purpose even more clear in that the connection is required to resist wind and seismic (lateral) forces. This proposal merely provides prescriptive methods to accomplish the connection whether with solid blocking or when solid blocking doesn't work.

In addition, another proposal that I have submitted rearranges the existing section to separate top plate connections from bottom plate connections since roof connections at the top plate differ from conditions where there is floor framing above. The two proposals are intended to work together and are shown at the end of the purpose statement combined as one.

Purpose: The current text of the IBC states the intention of connecting the braced wall line to the roof or floor diaphragm above in section 2308.3.2. A similar version of this proposal was adopted as an Oregon amendment for the adoption of the 2006 IBC (and the recent adoption of the 2009 IBC) and has worked well. Since then, countless hours have gone into developing proposals for both the IRC and the IBC in the 2009 code development process. The proposal for the IRC (which was the main focus) was successful and was approved for the 2009 IRC. The details for that proposal are the same ones submitted for this proposal. During the process of resolving opposition and developing a consensus two main changes were made to the proposals. First, based on engineering reports and historical data, an exception was made for low heel connections (9 1/4") in lower wind and seismic zones to not require the blocking. Second, the details for the high-heel blocking was modified to allow a 2" gap at the top to allow for venting (again, backed up by engineering data). Following the approval for the 2009 IRC an article was published in the Spring 2009 issue of *Wood Design Focus* addressing the issue. The article, "When is Roof Eave Blocking Required?", states, "Because the 2006 IRC lacks clarity on when roof eave blocking is required for lateral force transfer, IRC users and code officials are forced to interpret its intent on a case by case basis, often with varied results." "Fortunately, Section R602.10.6.2 of the 2009 IRC provides a reasonable solution that addresses the above concerns, places reasonable limits on past successful practices, and avoids the pitfalls of the 2006 IRC....".

This proposal does not add additional requirements to the code. This proposal clarifies that the connection needs to occur and provides prescriptive solutions when solid blocking is not possible or is impractical.

Per accepted engineering practice for lateral design loads, the floor and roof diaphragms transmit wind and seismic loads into the braced walls (engineered shearwalls or prescriptive braced panels). The fact that the diaphragm needs to be connected to the braced wall line is often not fully understood by plans examiners, inspectors and contractors. The typical requirement that is intended by the code is that solid blocking occur at this connection with the blocking connected to the top plate of the wall to transfer the diaphragm (plf) force to the wall top plates. This is evidenced in the IBC by the exception to irregular structures stating, "...lateral forces shall be transferred from the roof diaphragm to the braced wall by blocking of the ends of the trusses...". In order for the forces to be transferred there has to be a connection capable of transferring the diaphragm shear evenly to the top plates.

The condition that occurs at an increasing rate that brings this issue up is with cantilevered or high stub-heel trusses. In that construction method solid blocking (either with 2x or engineered wood products) is often not possible due to the height of the diaphragm above the top plate of the wall.

Without this clarification of the text it is a connection that may or may not occur based on what I have seen in the field and have discussed with code officials. The blocking that is called for in the code serves three functions. It provides closure to prevent animals, birds, etc. from entering the attic space, it prevents the trusses or rafters from "rolling over" and it transfers the diaphragm forces to the wall. Most code officials, inspectors and contractors understand the first two objectives. However, the latter is a concept that is often not fully understood. This needs to be perceived, understood and implemented in a uniform way.

In addition, rather than identify a problem without providing a solution, my proposal includes two details to accomplish this connection simply. The solutions are, in principle, fundamentally extending the braced wall sheathing to the roof diaphragm either vertically in the truss bays or horizontally through the soffit. No engineering or testing is required since it is just completing the load path with the already defined sheathing and nailing.

Without prescriptive provisions in the current code this condition would require engineering or, as stated in 2308.3.2, Exception to item 1 ".by other approved methods." would be left up to the Authority Having Jurisdiction to determine what is acceptable without any guidance or uniformity between jurisdictions.

Typically, the engineering solution would provide details similar to those included in this proposal. Therefore, the solution and construction costs would not change. Costs would be reduced by eliminating additional costs for engineering where these prescriptive solutions work.

If approved, the two proposals I have submitted for section 2308.3.2 would read as shown below when combined:

2308.3.2 Braced wall line connections. Wind and seismic lateral forces shall be transferred from the roof and floor diaphragms to braced wall lines and from the braced wall lines in upper stories to the braced wall lines in the story below in accordance with this sections 2308.3.2.1 and 2308.3.2.2.

2308.3.2.1 Bottom plate connection. Braced wall line bottom plates shall be connected to joists or full depth blocking below in accordance with Table 2304.9.1, Item 6, or to foundations in accordance with Section 2308.3.3.

2308.3.2.2 Top plate connection. Where joists or rafters are used, braced wall line top plates shall be fastened to joists, rafters or full-depth blocking above in accordance with Table 2304.9.1, Items 11, 12, 15 or 19 as applicable based on the orientation of the joists or rafters to the braced wall line. Blocking shall be a minimum of 2 inches (51 mm) nominal in thickness and equal to the depth of the truss at the wall line and shall be fastened to the braced wall line top plate as specified in Table 2304.9.1, Item 11.

Exception: Blocking at rafters need not be full depth when there are no braced wall lines above but shall extend to within 2 inches (51mm) from the sheathing above.

At exterior gable end walls, braced wall panel sheathing in the top story shall be extended and fastened to roof framing where the spacing between parallel exterior braced wall lines is greater than 50 feet (15 240 mm).

Where roof trusses are used and are installed perpendicular to an exterior braced wall line, lateral forces shall be transferred from the roof diaphragm to the braced wall by blocking of the ends of the trusses or by other approved methods providing equivalent lateral force transfer. Blocking shall be a minimum of 2 inches (51 mm) nominal in thickness and equal to the depth of the truss at the wall line and shall be fastened to the braced wall line top plate as specified in Table 2304.9.1, Item 11.

Exceptions:

1. For Seismic Design Categories C and less and wind speed zones less than 100 mph where the rafters, joists or trusses are perpendicular to the wall line below and the distance from the top plate is less than 9 ¼ inches (235 mm) solid blocking need not be provided when the perpendicular framing members or a parallel member such as a continuous rim joist or header is attached to the wall line per Table 2304.9.1
2. Where the roof sheathing is greater than 9-1/4 inches (235 mm) above the top plate solid blocking is not required when the rafters, joists or trusses are connected in accordance with one of the following methods:
 1. In accordance with Figure 2308.3.2 (1)
 2. In accordance with Figure 2308.3.2 (2)
 3. With full height engineered blocking panels designed for values listed in American Forest and Paper Association (AF&PA) Wood Frame Construction Manual for One- and Two-Family Dwellings (WFCM).
 4. Designed in accordance with accepted engineering methods.

Bibliography: "When is Roof Eave Blocking Required", by Jay H. Crandell, P.E., Robert Rice, Brian Foley, P.E., and Frank Woeste, PhD, P.E. Volume 19, Number 1, Spring 2009 Wood Design Focus, a quarterly publication of Forest Products Society, Madison WI..

Cost Impact: The code change proposal will not increase the cost of construction.

ICCFILENAME: RICE-S2-2308.3.2

Public Hearing Results

Committee Action:

Disapproved

Committee Reason: The proposed prescriptive requirements for braced wall panel top plate connections are not exactly like those in the IRC and there are different triggers. There were concerns expressed with the stability of the remote blocking option.

Assembly Action:

None

Individual Consideration Agenda

This item is on the agenda for individual consideration because a public comment was submitted.

Public Comment:

Robert Rice, Josephine County, OR, representing Southern Oregon Chapter of ICC requests Approval as Modified by this Public Comment.

Modify the proposal as follows:

2308.3.2 Braced wall line connections. Wind and seismic lateral forces shall be transferred from the roofs and floors to braced wall lines and from the braced wall lines in upper stories to the braced wall lines in the story below in accordance with this section.

Braced wall line top plates shall be fastened to joists, rafters or full-depth blocking above in accordance with Table 2304.9.1, Items 11, 12, 15 or 19 as applicable based on the orientation of the joists or rafters to the braced wall line. Braced wall line bottom plates shall be connected to joists or blocking below in accordance with Table 2304.9.1, Item 6, or to foundations in accordance with Section 2308.3.3. At exterior gable end walls, braced wall panel sheathing in the top story shall be extended and fastened to roof framing where the spacing between parallel exterior braced wall lines is greater than 50 feet (15 240 mm).

Where roof trusses are used and are installed perpendicular to an exterior braced wall line, lateral forces shall be transferred from the roof diaphragm to the braced wall by blocking of the ends of the trusses or by other approved methods providing equivalent lateral force transfer. Blocking shall be a minimum of 2 inches (51 mm) nominal in thickness and equal to the depth of the truss at the wall line and shall be fastened to the braced wall line top plate as specified in Table 2304.9.1, Item 11.

Exceptions:

1. For Seismic Design Categories C and less and wind speed zones less than 100 mph ~~For buildings that are classified as Seismic Design Category A, B or C and the basic wind speed is less than 100 mph (45 m/s)~~ where the framing members are perpendicular to the wall line below and the distance from the top plate to the sheathing above is less than 9 1/4 inches (235 mm) full-height solid blocking need not be provided when the perpendicular framing members or a parallel member such as a continuous rim joist or header is attached to the wall line in accordance with Table 2304.9.1.
2. Where the roof sheathing is greater than 9-1/4 inches (235 mm) above the top plate solid full-height blocking is not required when the framing members are connected in accordance with one of the following methods:
 - ~~2.4~~ 1. In accordance with Figure 2308.3.2 (1)
 - ~~2.2~~ 2. In accordance with Figure 2308.3.2 (2)
 - ~~2.3~~ 3. With full height engineered blocking panels designed for values listed in AF&PA WFCM.
 - ~~2.4~~ 4. Designed in accordance with accepted engineering methods.

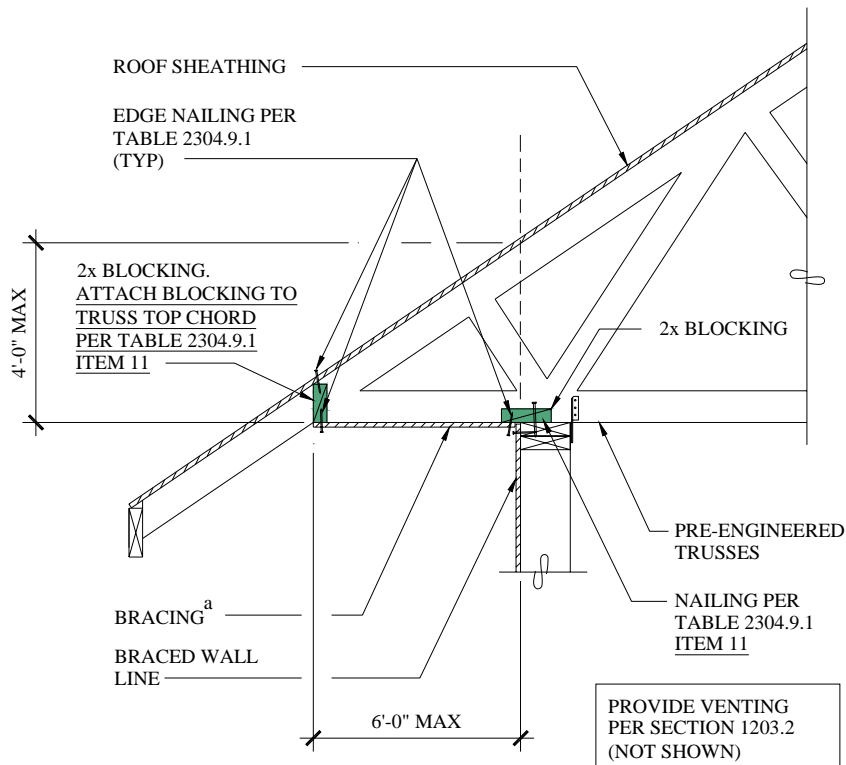

a. Methods of bracing shall be as described in Section 2308.9.3 method 2, 3, 4, 6, 7 or 8

For SI: 1 inch = 25.4 mm

FIGURE 2308.3.2 (1)
BRACED WALL PANEL TOP PLATE CONNECTION.

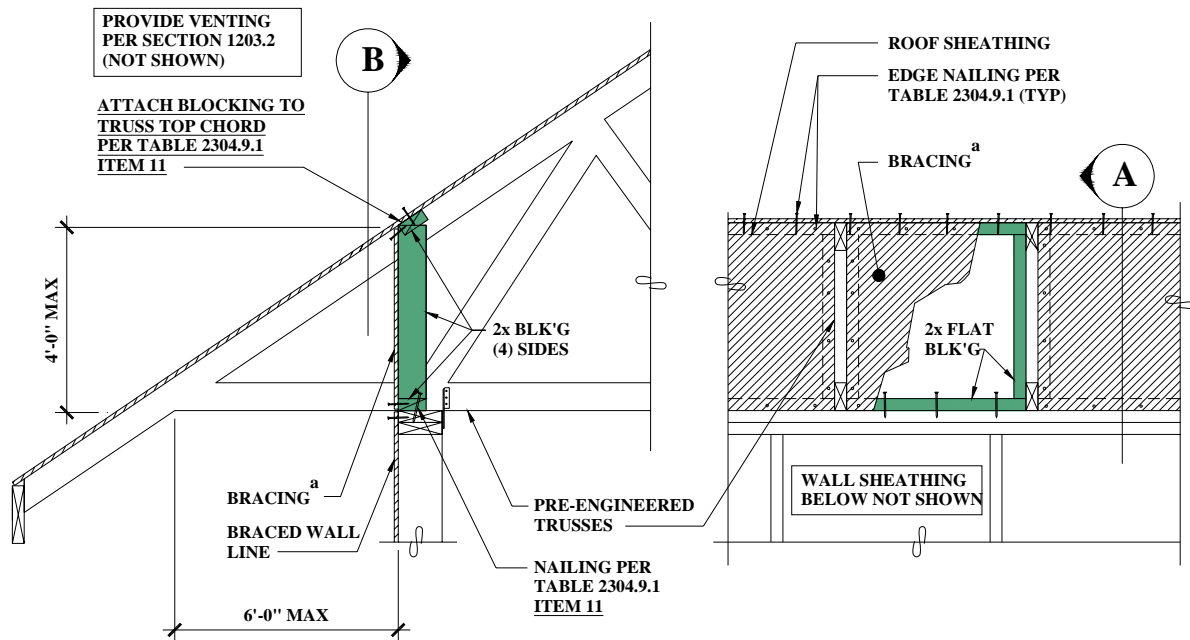

a. Methods of bracing shall be as described in Section 2308.9.3 methods 2, 3, 4, 6, 7 or 8

A SECTION

B ELEVATION

For SI: 1 inch = 25.4 mm

FIGURE 2308.3.2 (2)
BRACED WALL PANEL TOP PLATE CONNECTION.

TABLE 2304.9.1
FASTENING SCHEDULE

CONNECTION	FASTENING ^a	LOCATION
1. Joist to sill or girder	3 - 8d common (21/2" x 0.131") 3 - 3" x 0.131" nails 3 - 3" 14 gage staples	toenail
2. Bridging to joist	2 - 8d common (21/2" x 0.131") 2 - 3" x 0.131" nails 2 - 3" 14 gage staples	toenail each end
11. Blocking between joists, or rafters or trusses to top plate	3 - 8d common (21/2" x 0.131") 3 - 3" x 0.131" nails 3 - 3" 14 gage staples	toenail
<u>Blocking between rafters or truss chords, not at the wall top plate, to rafter or truss</u>	<u>2 - 8d common (21/2" x 0.131")</u> <u>2 - 3" x 0.131" nails</u> <u>2 - 3" 14 gage staples</u>	<u>toenail each end</u>
	<u>2 - 16d common (31/2" x 0.162")</u> <u>3 - 3" x 0.131" nails</u> <u>3 - 3" 14 gage staples</u>	<u>endnail</u>

(Portions of table not shown are unchanged)

Committer's Reason: The 2006 IBC had fairly clear wording that the diaphragms need to be connected to the braced wall line. With the approval of proposal 2008/2009 S224 the 2009 language was changed to make the purpose even more clear in that the connection is required to resist wind and seismic (lateral) forces. In addition, I submitted S211 09/10 and it was approved by committee in Baltimore. S211 09/10 rearranges the existing section 2308.3.2 to separate top plate connections from bottom plate connections since roof connections at the top plate differ from conditions where there is floor framing above. It also allows the blocking at the roof to have a maximum 2 inch gap from the roof sheathing to the blocking to allow venting. S211 09/10 and S212 09/10 are intended to work together and are shown combined at the end of this public comment.

At the code development hearings the committee expressed concern the details provided could be used on large buildings of five, six or more stories and were reluctant to not stay with the "solid full-height" blocking. In reality, the prescriptive provisions of "conventional light-frame construction" as provided for in section 2308 are very limited in scope. In section 2308.2 they are limited to:

1. Three stories max (two stories max in SDC C, one story in SDC D and above)
2. Max floor to floor height of 11'-7"
3. Max dead loads of 15 psf
4. Floor live load of 40 psf max
5. Ground snow 50 psf max
6. Wind speeds 100 max (w/ exception)
7. Roof truss span of 40 feet max between support
8. Occupancy Category IV buildings not allowed in SDC B,C,D,E or F
9. Limited by "irregular structures" definitions in 2308.12.6
10. More restrictive requirements for SDC B and above defined in 2308.11.
11. Braced wall line spacing 35 feet max each direction, each floor. In SDC D and E max spacing is 25 feet. (IRC allow exception up to 50 feet)

In other words, due to the limitations listed above as well as the other limitations in the code not listed here, the structures that are built with the provisions of section 2308 are small, light-framed buildings that do not have the significant lateral loading that other buildings do.

There was item that was raised by the committee regarding figure 2308.3.2(2). It was not specified in the detail how the top blocking is to attach to the truss or rafter. The note, "Nailing per table 2304.9.1" only pointed to the bottom blocking nailing to the top plate. At the hearings I pointed out that the significant load that this detail addresses is in the plane of the wall and that the blocking would be nailed in place by typical construction methods and was not a significant factor. This blocking is similar to 2x bridging that is often installed at the mid-span of joists. Table 2304.9.1 specifies fasteners for bridging in item 2. Item 11 of the table addresses the fasteners for the blocking between joists and rafters to the wall top plate. This public comment adds the same fasteners as bridging in item 2 to item 11 of the table where blocking between joists or rafters is not at the wall top plate. (Note: "trusses" was added to the existing table item but is merely editorial and has no bearing or impact on this proposal)

This proposal merely provides direction to accomplish the connection. It provides three prescriptive options when solid blocking doesn't work.

Purpose: The current code text (IBC) states the intention of connecting the braced wall line to the roof or floor diaphragm above in section 2308.3.2. A similar version of this proposal was adopted as an Oregon amendment for the adoption of the 2006 IBC and has worked well. Since then, countless hours have gone into developing proposals for both the IRC and the IBC in the 2009 code development process. The IRC proposal was approved in Minneapolis. During the process of resolving concerns and developing a consensus changes were made to the proposal. Based on engineering reports and historical data, an exception was made for low heel connections (9 1/4") in lower wind and seismic zones to not require the blocking.

This proposal does not add additional requirements to the code. This proposal clarifies that the connection needs to occur and provides prescriptive solutions when solid blocking, per the current text, is not possible or is impractical..

Per accepted engineering practice for lateral design loads, the floor and roof diaphragms transmit wind and seismic loads into the braced walls (engineered shearwalls or prescriptive braced panels). The fact that the diaphragm needs to be connected to the braced wall line to complete the load path is often not fully understood by plans examiners, inspectors and contractors. The typical requirement that is intended by the code is that full height solid blocking occur at this connection with edge nailing to the blocking and the blocking connected to the top plate of the wall to transfer the diaphragm (plf) force to the wall top plates. This is evidenced in the IBC by the exception to irregular structures stating, "*..lateral forces shall be transferred from the roof diaphragm to the braced wall by blocking of the ends of the trusses..*". In order for the forces to be transferred there has to be a connection capable of transferring the diaphragm shear evenly to the top plates.

The condition that occurs at an increasing rate that brings this issue up is with cantilevered or stub-heel trusses. In that construction method solid blocking (either with 2x or engineered wood products) is often not possible due to the height of the diaphragm above the top plate of the wall.

Without this clarification of the text it is a connection that may or may not occur based on what I have seen in the field and have discussed with code officials. The blocking that is called for in the code serves three functions. It provides closure to prevent animals, birds, etc. from entering the attic space, it prevents the trusses or rafters from "rolling over" and it transfers the diaphragm forces to the wall. Most code officials, inspectors and contractors understand the first two objectives. However, the latter is a concept that is often not fully understood. This needs to be perceived, understood and implemented in a uniform way.

In addition, rather than identify a problem without providing a solution, my proposal includes two details to accomplish this connection simply. The solutions are, in principle, fundamentally extending the roof diaphragm sheathing to the wall top plates either vertically in the truss bays or horizontally through the soffit. No engineering or testing is required since it is just completing the load path with the already defined sheathing and nailing.

Without prescriptive provisions in the current code this condition would require engineering or, as stated in 2308.3.2, Exception to item 1 "*..by other approved methods.*" would be left up to the Authority Having Jurisdiction to determine what is acceptable without any guidance or uniformity between jurisdictions.

Typically, the engineering solution would provide details similar to those included in this proposal. Therefore, the solution and construction costs would not change. Costs would be reduced by eliminating additional costs for engineering where these prescriptive solutions work.

I had also submitted proposal S211 09/10 for this same code section and it was approved by committee in Baltimore. S211 09/10 reorganizes section 2308.3.2. If this public comment to S212 is approved, section 2308.3.2 would read as shown below when the two are combined:

2308.3.2 Braced wall line connections. *Wind and seismic lateral forces shall be transferred from the roofs and floor diaphragms to braced wall lines and from the braced wall lines in upper stories to the braced wall lines in the story below in accordance with this section.*

2308.3.2.1 Bottom plate connection. *Braced wall line bottom plates shall be connected to joists or full-depth blocking below in accordance with Table 2304.9.1, Item 6, or to foundations in accordance with Section 2308.3.3.*

2308.3.2.2 Top plate connection. *Where joists and/or rafters are used, braced wall line top plates shall be fastened to joists, rafters, rimboard or blocking above in accordance with Table 2304.9.1, Items 11, 12, 15 or 19 as applicable based on the orientation of the joists or rafters to the braced wall line. Blocking at joists with walls above shall be equal to the depth of the joist at the braced wall line. Blocking at rafters need not be full depth but shall extend to within 2 inches (51 mm) from the roof sheathing above. Blocking shall be a minimum of 2 inches (51 mm) nominal in thickness and shall be fastened to the braced wall line top plate as specified in Table 2304.9.1, Item 11.*

At exterior gable end walls, braced wall panel sheathing in the top story shall be extended and fastened to roof framing where the spacing between parallel exterior braced wall lines is greater than 50 feet (15 240 mm).

Where roof trusses are used and are installed perpendicular to an exterior braced wall line, lateral forces shall be transferred from the roof diaphragm to the braced wall by blocking of the ends of the trusses or by other approved methods providing equivalent lateral force transfer. Blocking shall be a minimum of 2 inches (51 mm) nominal in thickness and equal to the depth of the truss at the wall line and shall be fastened to the braced wall line top plate as specified in Table 2304.9.1, Item 11.

Exceptions:

1. For Seismic Design Categories C and less and wind speed zones less than 100 mph where the framing members are perpendicular to the wall line below and the distance from the top plate to the sheathing above is less than 9 1/4 inches (235 mm) solid, full-height blocking need not be provided when the perpendicular framing members or a parallel member such as a continuous rim joist or header is attached to the wall line per Table 2304.9.1
2. Where the roof sheathing is greater than 9-1/4 inches (235 mm) above the top plate solid full-height blocking is not required when the framing members are connected in accordance with one of the following methods:
 1. In accordance with Figure 2308.3.2 (1)
 2. In accordance with Figure 2308.3.2 (2)
 3. With full height engineered blocking panels designed for values listed in American Forest and Paper Association (AF&PA) Wood Frame Construction Manual for One- and Two-Family Dwellings (WFCM).
 4. Designed in accordance with accepted engineering methods.

Final Action: AS AM AMPC_____ D

S213-09/10

2308.9.2.3

Proposed Change as Submitted

Proponent: Edwin Huston, National Council of Structural Engineers Associations- Code Advisory Committee - General Requirements Subcommittee

Revise as follows:

2308.9.2.3 Nonbearing walls and partitions. In nonbearing walls and partitions, studs shall be spaced not more than ~~28~~ 24 inches (714 ~~609~~ mm) o.c. and in interior nonbearing walls and partitions, are permitted to be set with the long dimension parallel to the wall. Interior nonbearing partitions shall be capped with no less than a single top plate installed to provide overlapping at corners and at intersections with other walls and partitions. The plate shall be continuously tied at joints by solid blocking at least 16 inches (406 mm) in length and equal in size to the plate or by 1/2-inch by 1 1/2-inch (12.7 mm by 38 mm) metal ties with spliced sections fastened with two 16d nails on each side of the joint.

Reason: The ICC Structural Committee liked the idea of Code Change Proposal S228-07/08 but thought it was unclear. NCSEA was not the author of S228-07/08, but is now proposing a change to this section to address what we see as a potential safety concern for wind loading. Section 2308.9.2.3 allows 2x studs to be placed flat wise in a wall and be spaced at up to 28" oc. Table 2308.9.1 limits the height of edge wise studs in such a wall to 14 feet for 2x4 nonbearing walls, for example. Our Code Change Proposal is aimed at limiting this construction to interior walls. Tall flat wise stud construction is not appropriate for exterior walls which are subject to wind loads.

We are also recommending that the 28" spacing in Section 2308.9.2.3 should be changed to 24" oc. Table 2308.9.1 limits the maximum spacing of edge wise studs in all non-bearing walls to 24". Turning the stud and using it flat wise in the wall, should not let the stud spacing increase. We also note that in modern construction almost all wall framing is based on modules which fit within dimensions of 48" or 96". A spacing of 24" oc is a module of 48" and 96" but a spacing of 28" oc is not.

Cost Impact: This code change proposal will not increase the cost of construction.

ICCFILENAME: HUSTON-S1-2308.9.2.3

Public Hearing Results

Committee Action:

Disapproved

Committee Reason: The proposal did not adequately justify reducing stud spacing from 28 to 24 inches. There may be some 28 inch applications currently that would be affected. The remainder of the proposal is acceptable but the proponent should consider an adjustment in a public comment.

Assembly Action:

None

Individual Consideration Agenda

This item is on the agenda for individual consideration because a public comment was submitted.

Public Comment:

Edwin Huston, National Council of Structural Engineers Associations (NCSEA), representing NCSEA Code Advisory Subcommittee – General Requirements Subcommittee, requests Approval as Modified by this Public Comment.

Modify the proposal as follows:

2308.9.2.3 Nonbearing walls and partitions. In nonbearing walls and partitions, studs shall be spaced not more than ~~24~~ 28 inches (~~711~~ 711 ~~609~~ mm) oc. and in interior nonbearing walls and partitions, are permitted to be set with the long dimension parallel to the wall. Interior nonbearing partitions shall be capped with no less than a single top plate installed to provide overlapping at corners and at intersections with other walls and partitions. The plate shall be continuously tied at joints by solid blocking at least 16 inches (406 mm) in length and equal in size to the plate or by 1/2-inch by 1 1/2-inch (12.7 mm by 38 mm) metal ties with spliced sections fastened with two 16d nails on each side of the joint

Commenter's Reason: The ICC Structural Committee liked the idea of Code Change Proposal S213-09/10 but there was testimony in opposition to the change from 28" oc. to 24" oc. The ICC Structural Committee urged NCSEA to provide a Public Comment. NCSEA is providing this Public Comment to address what we see as a potential safety concern for wind loading. Section 2308.9.2.3 allows 2x studs to be placed flat wise in a wall and be spaced at up to 28" oc. Table 2308.9.1 limits the height of edge wise studs in such a wall to 14 feet for 2x4 nonbearing walls, for example. S213-09/10 is aimed at limiting this construction to interior walls. Tall flat wise stud construction is not appropriate for exterior walls which are subject to wind loads. Using tall, flat wise studs in an exterior wall, could lead to failure under wind loading.

Due to the testimony about the change in the maximum spacing to 28" this change is not being proposed.

Final Action: AS AM AMPC____ D

S214-09/10-PART I

2308.9.4

Proposed Change as Submitted

Proponent: Robert Rice, Grants Pass, representing Josephine County Building Safety and Southern Oregon Chapter International Code Council.

PART I – IBC STRUCTURAL

Revise as follows:

2308.9.4 Cripple walls. Foundation cripple walls shall ~~be framed of studs not be less in size than the required width of the studding above with a minimum length of 14 inches (356 mm), or the wall shall be framed of solid blocking or other approved method to prevent the studs from splitting.~~ Where exceeding 4 feet (1219 mm) in height, such walls shall be framed of studs having the size required for an additional story.

Reason: There are situations where the wall above is of studs larger than what would be required for structural reasons. In some cases it is to accommodate increased insulation or for tall walls. Typically, a 2x4 cripple wall is structurally sufficient even though the wall above may be 2x 6 for insulation reasons or 2x 8 for tall studs. The words "...required width..." would clear this up.

Regarding the 14" studs, this code section has been modified in the past by Oregon amendment and perhaps been misunderstood by others. The purpose for "Cripple walls with a stud height less than 14 inches...", to be sheathed does not relate to lateral bracing as the Oregon amendment implies,

For example, the Oregon amendment reads as follows:

Cripple walls with a stud height less than 14 inches (356 mm) supporting exterior walls or an interior braced wall line which is supported by a continuous foundation as required by Section 602.10.9 shall be sheathed on at least one side with a wood structural panel that is fastened to both the top and bottom plates in accordance with Table R602.3(1), or the cripple walls shall be constructed of solid blocking.

The intention of this code requirement is to ensure structural stability of walls with studs that are short enough to be susceptible to splitting. The 14" limit is due to the fact that, historically, up to 14" dimensional lumber was available to be used as solid blocking in lieu of the short studs. In addition, the proposal states, "or other approved method" since mechanical anchors are currently available that would allow the studs to be attached to the top and bottom plate without damaging the studs.

With the provision contained in R602.9, studs shorter than 14" can be used as long as sheathing is placed on one side of the wall to maintain the integrity of the studs and plates. The text continues, "...or the cripple walls shall be constructed of solid blocking." which would allow a number of products, now available, to be used such as glue-laminated beams (GLB), laminated veneer lumber beams (LVL) or dimensional lumber such as 4x's and 6x's.

The IRC commentary states, "The minimum length of 14 inches for cripple wall studs provides sufficient clear space for required nailing of the framing". The IBC commentary states, "The minimum stud length of 14 inches is based on the length necessary to properly fasten the studs to the foundation wall plate and the double plate above."

In addition, "Section R602.9 Cripple Walls" appears in the wall "framing" portion of the code. Wall "bracing" begins to be addressed in section R602.10. In Section R602.10.2 "Cripple wall bracing" is addressed specifically.

In summary, section "R602.9 Cripple Walls" has nothing to do with lateral bracing.

Cost Impact: The code change proposal will not increase the cost of construction.

ICCFILENAME: RICE-S-2308.9.4

Public Hearing Results

PART I- IBC STRUCTURAL

Committee Action:

Disapproved

Committee Reason: The proposed revisions to cripple wall are poorly worded and would not make the code any clearer.

Assembly Action:

None

Individual Consideration Agenda

This item is on the agenda for individual consideration because a public comment was submitted.

Public Comment:

Robert Rice, Josephine County Oregon, representing Southern Oregon Chapter of ICC, requests Approval as Modified by this Public Comment.

Replace proposal as follows:

PART I –IBC STRUCTURAL

2308.9.4 Cripple walls. Foundation cripple walls shall be framed of studs not less in size than the studding above, ~~with a minimum length of 14 inches (356 mm), or shall be framed of solid blocking.~~

Exception: Cripple wall studs are permitted to be smaller in size than the studding above when the wall above is separated by a floor system that is supported by the cripple wall and the studding in the wall above is larger than required per Table 2308.9.1 provided the cripple wall studs comply with Table 2308.9.1.

Where exceeding 4 feet (1219 mm) in height, such walls shall be framed of studs having the size required for an additional story. Cripple walls shall be framed with studs not less than 14 inches (356 mm) in height or the wall shall be framed of solid blocking.

Exception: Cripple walls with studs less than 14 inches (356 mm) in height shall be permitted when the cripple wall is continuously sheathed on at least one side with wood structural panels fastened to both the top and bottom plates in accordance with Table 2304.9.1.

Commenter's Reason: The original S214 proposal attempted to address two concerns with cripples walls. First, the existing text has the unintended consequence of being overly restrictive in certain construction methods. In the case of crawlspace construction it is common to have cripple walls where the site is not level. Tables R602.3(5) and R602.3.1 in the IRC and Table 2308.9.1 in the IBC establish the stud size, height and spacing for vertical gravity, wind and seismic loads. However, there are cases where the studs are larger than necessary per the tables. For instance, to accommodate required wall insulation 2x 6 studs may be used where 2 x 4 would work per the tables. In crawlspace construction when a cripple wall is used to support the floor system the current text would require that the cripple wall be framed of 2x6 as well (see the IRC example below).

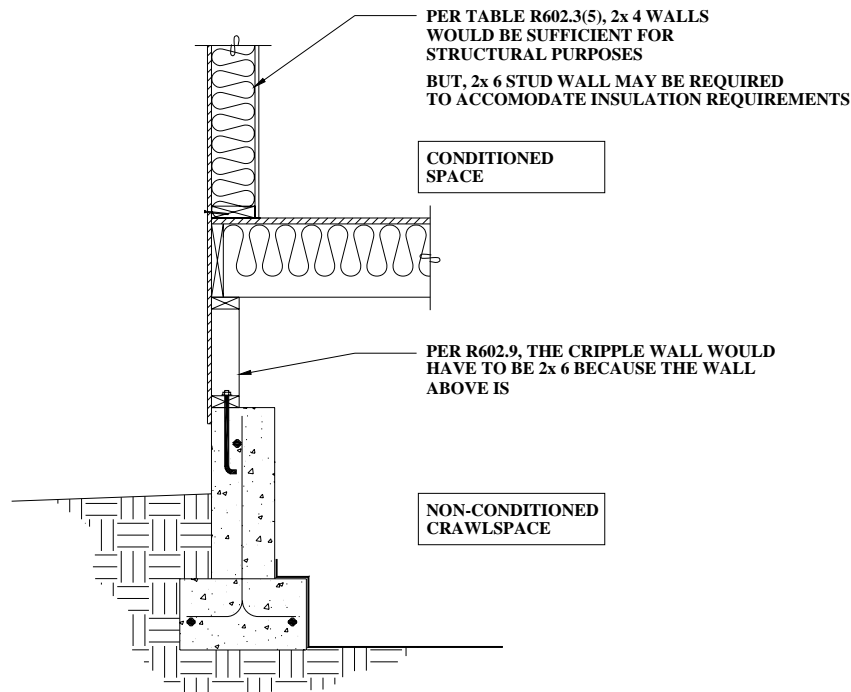

Also, the original proposal attempted to clarify that the requirement for sheathing when studs are less than 14 inches had nothing to do with wall bracing requirements. Some code officials, contractors and code adoption committees have misunderstood the intent of this section and apply it only when the cripple wall supports braced wall lines above. The intent is that wall studs less than 14 inches can be difficult to nail to plates without splitting and applying sheathing to one side adds stability to the studs in the wall.

This replacement of the original proposal would make the text more easily understood. The committee had concern about wording in the original proposal where it stated “...or other approved method to prevent studs form splitting” That language has been removed Also, the committee noted that RB106 that had been approved just prior to this proposal modified some language in this section. So, to ensure that there is no conflict, this amendment incorporates the approved language from RB106 from the Ad Hoc Wall Bracing Committee which stated, “...Cripple walls with studs less than 14 inches (356 mm) in height shall be permitted when the cripple wall is continuously sheathed on at least one side with a wood structural panels fastened to...”. No major changes are made to the current code text. In addition, the language has been rearranged to make the IRC and IBC sections more consistent. This proposal would reduce the cost of construction

Final Action: AS AM AMPC D

S214-09/10-PART II

IRC R602.9

Proposed Change as Submitted

Proponent: Robert Rice, Grants Pass, representing Josephine County Building Safety and Southern Oregon Chapter International Code Council.

PART II – IRC BUILDING/ENERGY

Revise as follows:

R602.9 Cripple Walls. Foundation cripple walls shall be framed of studs not smaller than required size of the studding above. When exceeding 4 feet (1219 mm) in height, such walls shall be framed of studs having the size required for an additional story.

Cripple walls with a stud height less than 14 inches (356 mm) shall be sheathed on at least one side with a wood structural panel that is fastened to both the top and bottom plates in accordance with Table R602.3(1) or other approved method to prevent studs from splitting or the cripple walls shall be constructed of solid blocking. Cripple

walls shall be braced as required for lateral loads per section R602.10.2 and R602.10.11.4 and supported on continuous foundations-

Reason: There are situations where the wall above is of studs larger than what would be required for structural reasons. In some cases it is to accommodate increased insulation or for tall walls. Typically, a 2x4 cripple wall is structurally sufficient even though the wall above may be 2x 6 for insulation reasons or 2x 8 for tall studs. The words "...required width..." would clear this up.

Regarding the 14" studs, this code section has been modified in the past by Oregon amendment and perhaps been misunderstood by others. The purpose for "Cripple walls with a stud height less than 14 inches...", to be sheathed does not relate to lateral bracing as the Oregon amendment implies,

For example, the Oregon amendment reads as follows:

Cripple walls with a stud height less than 14 inches (356 mm) supporting exterior walls or an interior braced wall line which is supported by a continuous foundation as required by Section 602.10.9 shall be sheathed on at least one side with a wood structural panel that is fastened to both the top and bottom plates in accordance with Table R602.3(1), or the cripple walls shall be constructed of solid blocking.

The intention of this code requirement is to ensure structural stability of walls with studs that are short enough to be susceptible to splitting. The 14" limit is due to the fact that, historically, up to 14" dimensional lumber was available to be used as solid blocking in lieu of the short studs. In addition, the proposal states, "or other approved method" since mechanical anchors are currently available that would allow the studs to be attached to the top and bottom plate without damaging the studs.

With the provision contained in R602.9, studs shorter than 14" can be used as long as sheathing is placed on one side of the wall to maintain the integrity of the studs and plates. The text continues, "...or the cripple walls shall be constructed of solid blocking." which would allow a number of products, now available, to be used such as glue-laminated beams (GLB), laminated veneer lumber beams (LVL) or dimensional lumber such as 4x's and 6x's.

The IRC commentary states, "The minimum length of 14 inches for cripple wall studs provides sufficient clear space for required nailing of the framing". The IBC commentary states, "The minimum stud length of 14 inches is based on the length necessary to properly fasten the studs to the foundation wall plate and the double plate above."

In addition, "Section R602.9 Cripple Walls" appears in the wall "framing" portion of the code. Wall "bracing" begins to be addressed in section R602.10. In Section R602.10.2 "Cripple wall bracing" is addressed specifically.

In summary, section "R602.9 Cripple Walls" has nothing to do with lateral bracing.

Cost Impact: The code change proposal will not increase the cost of construction.

ICCFILENAME: RICE-S-2308.9.4

Public Hearing Results

**PART II- IRC B/E
Committee Action:**

Disapproved

Committee Reason: This proposal needs additional information to define "method to prevent studs from splitting". The added reference sections may create potential problems with other sections of the code in the previously approved RB105-09/10 and RB106-09/10.

Assembly Action:

None

Individual Consideration Agenda

This item is on the agenda for individual consideration because a public comment was submitted.

Public Comment:

Robert Rice, Josephine County Oregon, representing Southern Oregon Chapter of ICC, requests Approval as Modified by this Public Comment.

Replace proposal as follows:

PART II –IRC BUILDING/ENERGY

R602.9 Cripple walls. Foundation cripple walls shall be framed of studs not smaller than the studding above.

Exception: Cripple wall studs are permitted to be smaller in size than the studding above when the wall above is separated by a floor system that is supported by the cripple wall and the studding in the wall above is larger than required per Tables R602.3(5) and R602.3.1 provided the cripple wall studs comply with Tables R602.3(5) and R602.3.1.

When exceeding 4 feet (1219 mm) in height, such walls shall be framed of studs having the size required for an additional story. ~~Cripple walls with a stud height less than 14 inches (356 mm) shall be sheathed on at least one side with a wood structural panel that is fastened to both the top and bottom plates in accordance with Table R602.3(1) or the cripple walls shall be constructed of solid blocking.~~ Cripple walls shall be framed with studs not less than 14 inches (356 mm) in height or the wall shall be constructed of solid blocking.

Exception: Cripple walls with studs less than 14 inches (356 mm) in height shall be permitted when the cripple wall is continuously sheathed on one side with a wood structural panels fastened to both the top and bottom plates in accordance with Table R602.3(1).

All cripple walls shall be supported on continuous foundations and braced as required for lateral loads in accordance with Section R602.10.9.

Commenter's Reason: See S214-09/10-Part I

Final Action: AS AM AMPC___ D

S223-09/10 2509.2

Proposed Change as Submitted

Proponent: Jose M. Estrada, representing USG Corporation

1. Revise as follows:

2509.2 Base for Tile. Glass mat water-resistant gypsum backing panel, discrete nonasbestos fiber-cement interior substrate sheets, water-resistant fiber-reinforced gypsum backers or nonasbestos fiber-mat reinforced cement substrate sheets in compliance with ASTM C 1178, C 1288, C 1278 or C 1325 and installed in accordance with manufacturer recommendations shall be used as a base for the wall tile in tub and shower areas and wall and ceiling panels in shower areas. Water-resistant gypsum backing board shall be used as a base for tile in water closet compartment walls when installed in accordance with GA -216 or ASTM C 840 and manufacturers recommendations. Regular gypsum wallboard is permitted under tile or wall panels in other wall and ceiling areas when installed in accordance with GA-216 or ASTM C 840.

Reason: The purpose of this proposal is to include an ASTM material standard for current provisions of the IBC. ASTM C 1278 products are engineered and manufactured specifically for interior water-resistant backing. The proposed ASTM material standard has been recognized by the International Residential Code (IRC) since the 2007 Supplement. The water-resistant products complying with this ASTM standard have a demonstrated track record, which has been documented substantially and historically, in consensus industry publications such as the TCA Handbook for Ceramic Tile Installation, published by the Tile Council of North America, where the ASTM C1278 products have been recognized for use in wet areas, including their use as a base for the wall tile in tub and shower surrounds since 2007. The wall and floor designs for the ASTM C1278 products listed in the TCA Handbook for wet area application are equivalent to those of ASTM C 1178, C 1288 and C 1325 products. The products covered under ASTM C 1278 for use as a base for tile have a proven track record in the field, where hundreds of millions of feet have been installed since its release to the market. The inclusion of this standard will allow for more competitive product bidding in turn reducing overall construction costs.

Bibliography:

The Tile Council of North America. 2009 TCA Handbook for Ceramic Tile Installation. Anderson, SC: TCNA, 2009.

Cost Impact: This code proposal will not increase the cost of construction.

ICCFILENAME: ESTRADA-S1-2509.2

Public Hearing Results

Committee Action:

Disapproved

Committee Reason: The documentation provided in the proponent's reason indicated these gypsum backers are not appropriate in the IBC for shower areas.

Assembly Action:

None

Individual Consideration Agenda

This item is on the agenda for individual consideration because a public comment was submitted.

Public Comment:

Richard P. Goldberg, AIA, CSI, NCARB, Professional Consultants International, LLC, representing United States Gypsum Company, requests Approval as Submitted.

Commenter's Reason: This public comment is written in objection to the disapproval of Code Change Proposal # S223-09/10 at the 09/10 Public Hearing, and in support of Final Action Hearing approval of same Code Change Proposal # S223-09/10 as submitted for the ICC Public Hearing consideration. The # S223-09/10 proposal requested the modification of §2509.2 and Chapter 35 Referenced Standards to include a water-resistant fiber-reinforced gypsum backer board complying with ASTM C1278 as an additional alternative to similar products previously approved for use by that section of the IBC Code in the 2004-05 code cycle.

As an architect and tile industry consultant, it is my opinion that the committee's disapproval action summarily dismissed consideration of the technical merits of the proposal, and was simply based on a misinterpretation of the proprietary product literature documentation provided in the proposal. The reason given for disapproval was that the proponent's documentation indicated that fiber-reinforced gypsum backers were not appropriate for shower areas under the IBC.

Product literature documentation did in fact indicate that the product was not intended for use as a tile backer panel in commercial gang shower areas. However, this situation is a "red herring", as the literature was simply consistent with IBC requirements current at the time of the proposal, and was not intended as an actual physical limitation of an ASTM C1278 compliant product for the purposes of the code change proposal. In other words, the proposal failed to recognize and explain the formality that the literature would be revised if the ASTM C1278 compliant product was approved for use as a tile backer under the IBC.

Our firm, PROCON, has conducted extensive independent laboratory testing comparing ASTM C 1178, ASTM C 1288, and ASTM C1325 compliant tile backers (currently approved for use in IBC §2509.2) with ASTM 1278 compliant water-resistant fiber-reinforced gypsum tile backers. This testing has determined that all four tile backer material standards provide equivalent performance under commercial wet-area conditions. These test results were an important factor in approval of water-resistant fiber-reinforced gypsum as a tile backer in wet areas, as recognized by both the IRC International Residential Code 2007 Supplement, as well as tile industry consensus publication Tile Council of North America (TCNA) 2007 Handbook for Ceramic Tile Installation.

Most important, the water resistance properties of the proposed ASTM C 1278 compliant product and the approved ASTM C1178 products (both gypsum-based) are comparable, including < 5% water absorption after 2 hours water immersion, no water percolation or wicking after 48 hrs., and mold resistance in accordance with ASTM D3273 (see attached supporting document # 1 & 2).

It is important to note that the TCNA tile industry consensus standard has recognized ASTM C 1278 compliant water-resistant fiber-reinforced gypsum as a backer for tile in wet areas, without discrimination as to residential or commercial construction applications (see attached supporting document # 3 & 4). The reason is that comparison of respective product category physical properties, as well as laboratory testing, has proven that ASTM C1278 compliant products meet or exceed the physical properties of ASTM C 1178, ASTM C 1288, and ASTM C1325 compliant tile backers currently approved for use in IBC § 2509.2.

I also call attention to the February 2005 ICC Public Hearing proposal and subsequent approval of proposal # S218-04/05 requiring the use of cement, fiber-cement, and glass mat gypsum backers in compliance with ASTM C1288, C 1325 & C 1178 respectively, to replace previously allowed water-resistant gypsum board ("green board") as a substrate for tile in tubs, showers and water closet compartments. Among other considerations, the premise of that approved code modification was "intended to bring the IBC in line with IRC in this respect", based on IRC approval in the 2003-04 code change cycle.

The modification sought by proposal # S223-09/10 is similar in spirit and in fact. Both IRC and TCNA tile industry consensus standards recognize ASTM C1288, C 1325, C 1178 and C 1278 compliant water-resistant fiber-reinforced gypsum as suitable tile backers in wet areas, yet there is no basis in fact for exclusion from the IBC, other than the misinterpretation of the proponent's documentation. The literature is simply a commercial reflection of current IBC requirements, but not reflective of the proponent's technical position.

The fact is that physical properties, testing and a proven history of ASTM C1278 compliant water-resistant fiber-reinforced gypsum as a tile backer in wet areas since release to the market in 2003 indicate that the material is suitable for use as a tile backer in commercial / institutional showers and tub surrounds. Most important (and the sole reason for Public Hearing disapproval), the proponent will revise literature by not limiting such use once that use is recognized by the IBC.

Therefore, I offer this public comment and reasoning in support of Final Action Hearing approval of the code change proposal # S223-09/10, as originally submitted, to modify IBC § 2509.2 and Chapter 35 Referenced Standards to include ASTM 1278 compliant water-resistant fiber-reinforced gypsum tile backer. This action will offer less restrictive, equivalent tile backer material standards, not change the cost of construction, with potential to reduce construction costs through increased competition.

Bibliography of supporting documentation:

1. Independent lab test results- Professional Consultants 2006 – comparison water resistance properties ASTM C1178 vs ASTM C1278 tile backer boards
2. Independent lab test results – TCNA Testing Service 2006 - comparison water percolation properties ASTM C1178 vs ASTM C1278 tile backer boards
3. Tile Council of North America TCNA 2008 Handbook for Ceramic Tile Installation – excerpt indicating 2007 approval of ASTM C 1278 as tile backer for wet area (commercial & residential)
4. Tile Council of North America TCNA 2008 Handbook for Ceramic Tile Installation – excerpt "wet area" definition.
5. Fiberock Aqua-tough Tile Backer Board (ASTM C1278)– USG technical literature – revisions to align with IBC approval.

SUPPORTING DOCUMENT # 1

**Test Results Summary
TCA and Independent Lab Product Testing Service
Comparison USG Fiberock and GP DensShield
Laboratory Samples**

TESTS	USG FIBEROCK ASTM C1278	GP DENSIELD ASTM C1178	ANSI 118.9
DRY TILE SHEAR BOND	274 psi	184 psi	50 psi
WET TILE SHEAR BOND	90 psi	49 psi	50 psi
12" WATER PERCOLATION, 48hrs	no visible water penetration/drops**	no visible water penetration / drops*	
24" WATER PERCOLATION, 48 hrs	no visible water penetration/drops** pass	no visible water penetration / drops* pass	
WATER WICKING, 48 hrs	0"	0"	
MOLD RESISTANCE ASTM D3273	No growth found		
* product contains membrane coating			
** product has intergral water resistance			
NOTE: THIS IS A SUMMARY OF TEST DATA; REFER TO FULL TCNA SUBMITTAL FOR DETAILED TCNA TEST REPORTS			
TCNA 2006 HANDBOOK SUBMISSION – USG Fiberock® Aqua Tough™ Tile Backerboard & Underlayment			
Professional Consultants International, LLC			
Atlanta, GA * Boston, MA * Hartford, CT 860-673-9529			



PRODUCT TESTING SERVICE

100 Clemson Research Blvd. Anderson, SC 29625 Tel (864) 646-TILE Fax (864) 646-2821

TCA TEST REPORT NUMBER: TCA-308-05

PAGE: 1 OF 1

TEST REQUESTED BY: USG Corporation
Research and Technology Center
Attn: John Ellicson
700 N. Highway 45
Libertyville, IL 60048

TEST SUBJECT MATERIAL: Identified by client as: ½-inch Denshield and Fiberock

TEST DATE: 1/13/06-1/14/06

TEST PROCEDURE: One two inch diameter tube, twelve inches long, with a square base was bonded to each sample with a silicone sealant. The silicone was allowed to cure for 48 hours before introducing the water. The tubes were filled with water to a height of twelve inches and then covered to minimize evaporation. The samples were placed on a stable surface in the laboratory and held at 74 degrees Fahrenheit and 45-55% R.H. After 48 hours the amount of water percolation (drop in water level) was recorded. The results are detailed below.

TEST RESULTS: Both samples (one Denshield and one Fiberock) exhibited a ¼-inch drop in the water level after 48 hours of the above detailed percolation test. The amount of loss that is due to evaporation is not known.



Noah Chitty
Director of Laboratory Services

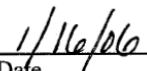

Date

Testing Services: testing@tileusa.com Literature Orders: literature@tileusa.com Web Site: www.tileusa.com
This report is confidential and has been prepared for the exclusive use of the client. It is not an endorsement, approval, certification, or criticism of any product by TCNA. This report shall not be published in any form without prior written consent of TCNA.

WALLS, INTERIOR

Wood or Metal Studs

Continued from previous page.

- 07 Materials:**
- coated glass mat, water-resistant gypsum backer board—ASTM C1178.
 - 2" alkali-resistant glass fiber mesh tape.
 - fasteners—noncorrosive and nonoxidizing.
 - dry-set mortar—ANSI A118.1.
 - latex-portland cement mortar—ANSI A118.4.
 - organic adhesive—ANSI A136.1, Type I for residential wet areas and Type II for dry areas.
 - grout—ANSI A118.3, A118.6, or A118.7.

- 07 Preparation by Other Trades:**
- maximum variation in the wood or metal studs—not to exceed 1/4" in 10'-0" and 1/16" in 1'-0" from the required plane.

- 07 Preparation by Backer Board Installers:**
- 2" alkali-resistant glass fiber mesh tape—embed in a skim coat of dry-set or latex-portland cement mortar over joints and corners.
 - caulk or seal penetrations and abutments to dissimilar materials.

Movement Joint (architect must specify type of joint and show location and details on drawings):

- movement joints—mandatory according to Method EJ171, page 79.

- Installation Specifications:**
- follow manufacturer's instructions.
 - tile—ANSI A108.4 or A108.5.
 - grout—ANSI A108.6 or A108.10.

07 Cementitious-Coated Foam Backer Board W246-07

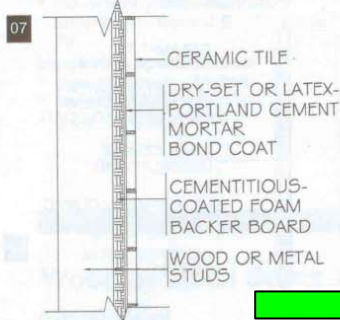

- Recommended Uses:**
- in wet or dry areas.
 - over dry, well-braced wood studs or furring.
 - over well-braced metal studs.
 - where waterproof properties are required.

- 07 Requirements:**
- set tile in dry-set or latex-portland cement mortar.
 - stud spacing—maximum 16" o.c.
 - minimum recommended stud depth—3-1/2".
 - metal studs—20 gauge (0.039") or heavier.
 - Fasten units to studs per manufacturer's recommendations.

- Materials:**
- cementitious-coated extruded foam backer board.
 - waterproofing for seams and fastener heads—ANSI A118.10.
 - fasteners—noncorrosive and nonoxidizing.
 - dry-set mortar—ANSI A118.1.
 - latex-portland cement mortar—ANSI A118.4.
 - grout—ANSI A118.3, A118.6, or A118.7.
 - metal studs—ASTM C645.

- 07 Preparation by Backer Board Installers:**
- maximum variation in the backing surface—1/4" in 10'-0" and 1/16" in 1'-0" from the required plane.
 - horizontal and vertical joints and corners—butt tightly together, and apply caulk (or silicone caulking) in joints and corners.

Movement Joint (architect must specify type of joint and show location and details on drawings):

- movement joints—mandatory according to Method EJ171, page 79.

- Installation Specifications:**
- cementitious-coated extruded foam backer board—install according to manufacturer's instructions.
 - tile—ANSI A108.5.
 - grout—ANSI A108.6 or A108.10.

07 Fiber-Reinforced Water-Resistant Gypsum Backer Board W247-07

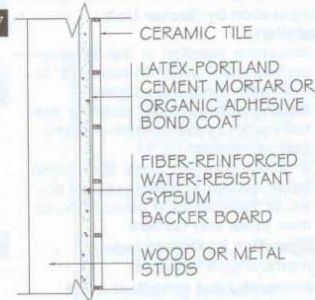

- 07 Recommended Uses:**
- in wet or dry areas.
 - over dry, well-braced wood studs or furring.
 - over well-braced metal studs.

- 07 Requirements:**
- set tile in latex-portland cement mortar or organic adhesive.
 - stud spacing—maximum 16" o.c. or 24" o.c. with blocking at all joints, ends, and edges.
 - minimum recommended stud depth—3-1/2".
 - metal studs—20 gauge (0.039") or heavier for tile applications.

- 07 Materials:**
- fiber-reinforced water-resistant gypsum backer board 1/2" or thicker—ASTM C1278 (Paragraph 6.1).
 - 2" alkali-resistant glass fiber mesh tape.
 - fasteners—noncorrosive and non-oxidizing.
 - latex-portland cement mortar—ANSI A118.4.

All specifications for ceramic tile installations must conform to local building codes, ordinances, trade practices, and climatic conditions.

Not all methods are suitable for glass tile installations. Consult glass tile manufacturer for specific recommendations.

Published by



COPYRIGHT © 2007 TILE COUNCIL OF NORTH AMERICA, INC.
 100 Clemson Research Blvd., Anderson, SC 29625
 Tel: 864-646-8453 □ Fax: 864-646-2821
 Web Site: www.tileusa.com

Continued on next page.

shadows are created from side lighting interior walls and floors when light shines at that angle through windows and doors.

Exterior:

When natural or artificial light shines on exterior walls and floors at a flat angle almost parallel to tile surfaces, normal and acceptable inconsistencies in the tilework are highlighted by shadows that exaggerate these conditions.

07 Wet Area Definition:



Tile surfaces that are either soaked, saturated, or regularly and frequently subjected to moisture or liquids (usually water), such as gang showers, tub enclosures, showers, laundries, saunas, steam rooms, swimming pools, hot tubs, commercial kitchens, and exterior areas.

Limited Water Exposure Area:

Tile surfaces that are subjected to moisture or liquids but do not become soaked or saturated due to the system design or the time exposure.

Examples include: residential bathroom floors and foyers, residential bathroom vertical surfaces including tub surrounds without a shower head, and kitchen countertops.

Mortar Bed Weight:

Typically, a 1" thick mortar bed will weigh 12 lbs. per square foot. A thin-bed typically weighs 0.5 lbs. to 1.5 lbs. per square foot.

Bonding Large-Format Tile for Coverage and Support:

The following installation techniques are required to ensure proper coverage of the bonding surface of larger tiles and provide full support of edges and corners. Large tiles are generally considered to be 8" x 8" and greater. Select a notched trowel sized to facilitate the proper coverage. Key the mortar into the substrate with the flat side of the trowel. Comb with the notched side of the trowel in ONE DIRECTION. Firmly press tiles into the mortar and move them perpendicularly ACROSS the ridges, forward and back approximately 1/8" to 1/4", to flatten the

ridges and fill the valleys. This method can produce maximum coverage, with the corners and edges fully supported, without backbuttering or beat-in. Periodically remove and check a tile to assure proper coverage is being attained.

07 Coefficient of Friction:

When coefficient of friction (COF) data are required for a specific project, testing shall conform to ASTM C1028. However, because area of use and maintenance by the owner of installed tile directly affect coefficient of friction, the COF of the manufactured product shall be as agreed upon by manufacturer and purchaser.

Water (especially standing water), oil, grease, etc., create slippery conditions. Floor applications with exposure to these elements require extra maintenance and caution in product selection.

Lippage:

Lippage is a condition where one edge of a tile is higher than an adjacent tile, giving the finished surface an uneven appearance. This condition is inherent in all installation methods and may also be unavoidable due to the tile tolerances, in accordance with ANSI A137.1.

Protecting New Tile Work:

To avoid damage to finished tilework, schedule floor installations to begin only after all structural work, building enclosure, and overhead finishing work, such as ceilings, painting, mechanical, and electrical work, are completed. Keep all traffic off finished tile floors until they have fully cured. Builder shall provide up to 3/4"-thick plywood or OSB protection over non-staining kraft paper to protect floors after installation materials have cured. Covering the floor with polyethylene or plywood in direct contact with the floor may adversely affect the curing process of grout and latex/polymer modified portland cement mortar.

07 Maintenance:

All tile installations (especially exterior installations, which include the movement joint sealant) require periodic inspection and maintenance by the owner. Consult material manufacturers and maintenance product manufacturers for recommended procedures.

CAUTION – Wood-based panels such as particle board, composite panels (veneer faces bonded to reconstituted wood cores), non-veneer panels (wafer board, oriented strand board, and other similar boards), lauan plywood, and softwood plywood expand and contract with changes in moisture content and are not recommended as backing materials for direct bonding of ceramic tile. Plywood, however, manufactured with fully waterproof adhesive and with an exposure durability rating of Exposure 1 or Exterior may be used on residential horizontal surfaces when installed in accordance to ANSI Specifications for the Installation of Ceramic Tile (A108.01-3.4).

Submittal Sheet

Fiberock® Aqua-Tough™ Tile Backerboard

Finishing flexibility, strength, and superior water resistance in a single panel

- Superior tile bond for ceramic tile
- Uniform composition provides both strength and water resistance
- Suitable for ceramic tile wall and tub surround applications in intermittently wet and dry areas

Description



FIBEROCK® brand AQUA-TOUGH™ tile backerboard is a unique fiber-reinforced gypsum product that represents a new era in substrate performance for wet or dry areas. This durable panel offers superior performance and tile bond because of its integral water-resistant core.

Unlike traditional water-resistant gypsum board, FIBEROCK tile backerboard derives both strength and water-resistance from its uniform composition. Made of a uniquely engineered gypsum/cellulose-fiber combination, FIBEROCK tile backerboard is strong and water resistant all the way through. With no paper to delaminate, FIBEROCK tile backerboard maintains its integrity even when wet.

Advantages



Abuse Resistant Engineered to provide increased resistance to abrasion, indentation and penetration. Outperforms paper-faced or glass mat faced panels. FIBEROCK tile backerboard has no paper face to tear or scratch.

Water Resistant FIBEROCK tile backerboard is water resistant through the core and intended for use in intermittently wet areas including tub surrounds.

Mold Resistant In independent lab tests per ASTM D3273-00 "Standard Test Method for Resistance to Growth of Mold on the Surface of Interior Coatings in an Environmental Chamber," the score for FIBEROCK tile backerboard was 10 (highest score).

Fire Resistant These panels offer superior fire resistance and demonstrate exceptional surface burning characteristics.

Finishing Flexibility FIBEROCK tile backerboard can be finished with ceramic tile or painted.

Environmentally Friendly Made from 95% recycled materials. Awarded Green Cross Certification from Scientific Certification Systems.

Limitations

1. Maximum stud spacing:

Wall Panel	Frame Spacing	Nails	Screws
1/2"	16" o.c.	8" o.c.	12" o.c.

2. For marble and stone applications, consult current TCA guidelines for recommendations.
3. Do not use in areas subject to prolonged exposure to standing water— for instance, in gang showers, saunas, or hot-tub decks.
4. FIBEROCK Tile Backerboard must be tiled or painted, not used as a finish surface.
5. Panels should not be exposed to sustained temperatures above 125 °F (51.6 °C).
6. For fire-resistant or abuse-resistant construction over steel framing, a minimum of 20 gauge steel framing is required.
7. Do not use in areas subject to standing water, such as gang showers, saunas or hot-tub decks.



Product Data



Dimensions: 1/2" FIBEROCK tile backerboard, 3' x 5', 4' x 4', 4' x 5' and 4' x 8', with square-edge configuration

Compliance with standards: Meets ASTM standard C1278

Installation Practices

Environmental Conditions

In cold weather and during FIBEROCK tile backboard installation, joint finishing, and tile application, temperatures within the building shall be maintained within the range of 55-70 °F. Adequate ventilation shall be provided to carry off excess moisture. Wood framing shall approximate the moisture content it will reach in service prior to the application of the panels. FIBEROCK tile backerboard should be stored in an enclosed shelter providing protection from damage and exposure to the elements. Allow FIBEROCK backerboard to acclimate to the temperature and humidity conditions at the jobsite prior to installation.

Framing

Steel or wood wall framing to receive FIBEROCK tile backerboard shall be structurally sound and in general compliance with local building code requirements. Damaged and excessively bowed studs shall be replaced before installation of FIBEROCK tile backerboard.

Space wood and steel framing a maximum of 24" o.c. Framing shall be designed to meet L/360 deflection for tile and L/240 for flexible finishes such as paint. For floor applications, framing shall be designed to meet L/360 deflection.



Final Action: AS AM AMPC D

S226-09/10, Part II

IRC: R902.1

NOTE: PART I DID NOT RECEIVE A PUBLIC COMMENT AND IS ON THE CONSENT AGENDA. PART I IS REPRODUCED ONLY FOR INFORMATIONAL PURPOSES ONLY FOLLOWING ALL OF PART II.

Proposed Change as Submitted

Proponent: Craig Thompson, representing Copper Development Assn.

PART II – IRC BUILDING/ENERGY

R902.1 Roofing covering materials. Roofs shall be covered with materials as set forth in Sections R904 and R905. Class A, B or C roofing shall be installed in areas designated by law as requiring their use or when the edge of the roof is less than 3 feet (914 mm) from a property line. Classes A, B and C roofing required by this section to be listed shall be tested in accordance with UL 790 or ASTM E 108.

Exceptions:

1. Class A roof assemblies include those with coverings of brick, masonry and exposed concrete roof deck.
2. Class A roof assemblies also include ferrous or copper shingles or sheets, metal sheets and shingles, clay or concrete roof tile, or slate installed on non-combustible decks.
3. Class A roof assemblies include copper sheets installed over combustible decks.

Reason: : The reason the exceptions clause was modified in the last code cycle was primarily due to a test report submitted by the National Association of State Fire Marshalls from Underwriters Laboratories Inc., (UL), dated January 17, 2007. The report references the findings of a fact finding report done by UL to show that the exceptions to the Class A rating are not valid because, as the fact finding report shows, 30 gauge sheet steel, 24 gauge sheet steel, 0.040 aluminum sheet & 14" X 10" wide , 6" exposure slate installed over A-C plywood do not pass fire test requirements under Standards E108 & UL970 for roof coverings used over combustible roof deck. However this same report states that 16 oz. copper sheet does conform to fire test requirements under Standards E108 & UL 970. The report affirms that the copper roof assembly does pass. Therefore there is no viable reason why copper shingles or sheets should not retain their exception as a Class A roof material. In addition, for the UL test to be valid each assembly must pass four consecutive burning brand tests, two consecutive flame spread tests and two consecutive intermittent flame tests as spelled out in ASTM E108 & UL970. Each assembly was tested only once in the Fire Marshall's report, not as per the standard, thus nullifying the report's conclusions.

In addition, as per the attached report from the Southwest Research Institute, (SwRI), a typical standing seam copper roof assembly, over a combustible deck, was tested and passed as per ASTM E108 for Class A roof assemblies. ASTM E108 is the recognized standard by which all Class A roof assemblies are measured. Therefore the typical copper standing seam roof assembly, on a combustible deck, should rightfully be listed as a Class A roof assembly exception as per the SwRI report dated 1/7/09.

Bibliography:

1. Southwest Research Institute; *Evaluation of the External Fire Resistance Characteristics of Roof Covering Systems in Accordance with ASTM E 108-07a, Standard Test Methods for Fire Tests of Roof Coverings: Class A Testing*; San Antonio, TX, January 7, 2009
2. Underwriters Laboratories; *Fact –Finding Investigation of Metal and Slate Prepared Roof Coverings*; National Association of State Fire Marshalls, Washington, DC; Northbrook, IL, January 17, 2007

Cost Impact: None given.

ICCFILENAME: THOMPSON, C-S1-1505.2

Public Hearing Results

PART II- IRC B/E

Committee Action:

Approved as Submitted

Committee Reason: Copper sheets installed on a combustible deck are Class A and was inadvertently omitted last code change cycle as stated in the proponent's published reason. This change brings this roof covering back into the code as Class A and exempt from testing.

Assembly Action:

None

Individual Consideration Agenda

This item is on the agenda for individual consideration because public comments were submitted.

Public Comment 1:

Bob Eugene, Underwriters Laboratories Inc, requests Approval as Modified by this Public Comment.

Modify the proposal as follows:

R902.1 Roofing covering materials. Roofs shall be covered with materials as set forth in Sections R904 and R905. Class A, B or C roofing shall be installed in areas designated by law as requiring their use or when the edge of the roof is less than 3 feet (914 mm) from a property line. Classes A, B and C roofing required by this section to be listed shall be tested in accordance with UL 790 or ASTM E 108.

Exceptions:

1. Class A roof assemblies include those with coverings of brick, masonry and exposed concrete roof deck.
2. Class A roof assemblies also include ferrous or copper shingles or sheets, metal sheets and shingles, clay or concrete roof tile, or slate installed on non-combustible decks.
3. Class A roof assemblies include minimum 16 oz/ft² copper sheets installed over combustible decks.

Commenter's Reason: Added text is consistent with the action of the IBC Fire Safety Committee.

Public Comment 2:

John Woestman, Kellen Company, and Craig Thompson, representing Copper Development Assn., requests Approval as Modified by this Public Comment.

Modify the proposal as follows:

R902.1 Roofing covering materials. Roofs shall be covered with materials as set forth in Sections R904 and R905. Class A, B or C roofing shall be installed in areas designated by law as requiring their use or when the edge of the roof is less than 3 feet (914 mm) from a property line. Classes A, B and C roofing required by this section to be listed shall be tested in accordance with UL 790 or ASTM E 108.

Exceptions:

1. Class A roof assemblies include those with coverings of brick, masonry and exposed concrete roof deck.
2. Class A roof assemblies also include ferrous or copper shingles or sheets, metal sheets and shingles, clay or concrete roof tile, or slate installed on non-combustible decks.
3. Class A roof assemblies include minimum 16 oz/ft² copper sheets installed over combustible decks.

Commenter's Reason: This proposed modification sets minimum copper sheet specifications consistent with the testing performed, as referenced in the original proposal, and is consistent with the language recommended for approval for the IBC in S226 Part I

Final Action: AS AM AMPC____ D

NOTE: PART I REPRODUCED FOR INFORMATIONAL PURPOSES ONLY –SEE ABOVE

S226-09/10-PART I – IBC FIRE SAFETY

Revise as follows:

1505.2 Class A roof assemblies. Class A roof assemblies are those that are effective against severe fire test exposure. Class A roof assemblies and roof coverings shall be listed and identified as Class A by any approved testing agency. Class A roof assemblies shall be permitted for use in buildings or structures of all types of construction.

Exceptions:

1. Class A roof assemblies include those with coverings of brick, masonry and exposed concrete roof deck.
2. Class A roof assemblies also include ferrous or copper shingles or sheets, metal sheets and shingles, clay or concrete roof tile, or slate installed on non-combustible decks or ferrous, copper or metal sheets installed without a roof deck on noncombustible framing.
3. Class A roof assemblies include copper sheets installed over combustible decks.

Reason: : The reason the exceptions clause was modified in the last code cycle was primarily due to a test report submitted by the National Association of State Fire Marshalls from Underwriters Laboratories Inc., (UL), dated January 17, 2007. The report references the findings of a fact finding report done by UL to show that the exceptions to the Class A rating are not valid because, as the fact finding report shows, 30 gauge sheet steel, 24 gauge sheet steel, 0.040 aluminum sheet & 14" X 10" wide , 6" exposure slate installed over A-C plywood do not pass fire test requirements under Standards E108 & UL970 for roof coverings used over combustible roof deck. However this same report states that

16 oz. copper sheet does conform to fire test requirements under Standards E108 & UL 970. The report affirms that the copper roof assembly does pass. Therefore there is no viable reason why copper shingles or sheets should not retain their exception as a Class A roof material. In addition, for the UL test to be valid each assembly must pass four consecutive burning brand tests, two consecutive flame spread tests and two consecutive intermittent flame tests as spelled out in ASTM E108 & UL970. Each assembly was tested only once in the Fire Marshall's report, not as per the standard, thus nullifying the report's conclusions.

In addition, as per the attached report from the Southwest Research Institute, (SwRI), a typical standing seam copper roof assembly, over a combustible deck, was tested and passed as per ASTM E108 for Class A roof assemblies. ASTM E108 is the recognized standard by which all Class A roof assemblies are measured. Therefore the typical copper standing seam roof assembly, on a combustible deck, should rightfully be listed as a Class A roof assembly exception as per the SwRI report dated 1/7/09.

Bibliography:

1. Southwest Research Institute; *Evaluation of the External Fire Resistance Characteristics of Roof Covering Systems in Accordance with ASTM E 108-07a, Standard Test Methods for Fire Tests of Roof Coverings: Class A Testing*; San Antonio, TX, January 7, 2009
2. Underwriters Laboratories; *Fact –Finding Investigation of Metal and Slate Prepared Roof Coverings*; National Association of State Fire Marshals, Washington, DC; Northbrook, IL, January 17, 2007

Cost Impact: None given

PART I- IBC FIRE SAFETY

Committee Action:

Approved as Modified

Modify the proposal as follows:

1505.2 Class A roof assemblies. Class A roof assemblies are those that are effective against severe fire test exposure. Class A roof assemblies and roof coverings shall be listed and identified as Class A by any approved testing agency. Class A roof assemblies shall be permitted for use in buildings or structures of all types of construction.

Exceptions:

1. Class A roof assemblies include those with coverings of brick, masonry and exposed concrete roof deck.
2. Class A roof assemblies also include ferrous or copper shingles or sheets, metal sheets and shingles, clay or concrete roof tile, or slate installed on non-combustible decks or ferrous, copper or metal sheets installed without a roof deck on noncombustible framing.
3. Class A roof assemblies include minimum 16 oz/ft² copper sheets installed over combustible decks.

Committee Reason: The committee agreed that copper sheets over combustible decking was appropriate for a prescribed class A roof assembly based on the testing submitted with the proposal. The modification includes the necessary minimum copper sheet specifications that are tied to the testing performed.

Assembly Action:

None

S229-09/10

2211.1 (New), 2211.2 (New), Chapter 35

Proposed Change as Submitted

Proponent: Victor D. Azzi, PhD, PE, Consulting Structural Engineer, representing the Storage Equipment Manufacturers Association (SMA), a division of the Material Handling Industry of America (MHIA).

1. Add new text as follows:

SECTION 2211 **INDUSTRIAL STEEL WORK PLATFORMS**

2211.1 General. The design, testing, utilization, application, and maintenance of industrial steel work platforms shall be in accordance with the provisions of ANSI/SMA MH28.3. An industrial steel work platform is herein defined as a pre-engineered, prefabricated, elevated platform, employing a steel framing system, located in an industrial environment. Other structural or nonstructural elements shall be permitted for flooring including but not limited to, concrete, steel, and engineered wood products. Personnel working on such platforms are trained employees, accustomed to a manufacturing environment and dressed accordingly.

2211.2 Materials. Steel shall be in accordance with the ASTM specifications listed in AISI S100 and AISC 360. Steels not listed in the above specifications are not excluded, provided that they conform to the chemical and mechanical properties of one or more of the listed specifications, or of other specifications which establish their properties and structural suitability, and provided that they are subjected by either the producer or the purchaser to analyses, tests, and other controls to the extent and in the manner prescribed by one of the listed specifications, as applicable.

Materials used in the decking structure and surfaces for these work platforms shall be concrete, engineered wood products, plywood or other wood products, steel sheet, steel plate or grating, supported by the steel framing system. Such decking materials shall conform to the applicable provisions of this code and referenced standards appropriate to their use in this application and work environment.

2. Add standard to Chapter 35 as follows:

SMA

MH28.3-08 Specification for the Design, Manufacture and Installation of Industrial Steel Work-Platforms.

Reason: The Engineering committees of the Storage Equipment Manufacturers Association (SMA), have worked to develop standard engineering practices for the design, testing, and utilization of Industrial Steel Work Platforms. The use of this standard permits loading capacities and performance ratings, as well as functional requirements, to be determined and verified by designers and users of these products. The SMA, a Product Section of the Material Handling Industry of America (MHIA), comprises the substantial portion of the companies that design and manufacture the preponderance of industrial steel work platforms as defined by the scope of this standard. The SMA has recognized the need to establish rigorous industry standards, and have supported the development and promulgation of the ANSI/SMA standard for the benefit of the work-platform industry as well as the users of its products. This SMA/ANSI Standard has been developed using the canvassing processes of the MHIA and the ANSI. The ANSI canvassing process for this new ANSI MH28.3 Standard was recently completed and the SMA Engineering Committee has resolved several items involving small editorial changes and corrections.

Cost Impact: This addition to the IBC will not increase the cost of construction.

ICCFILENAME: AZZI-S1-2211 (New)

Public Hearing Results

This code change was contained in the errata posted on the ICC website. Please go to <http://www.iccsafe.org/cs/codes/Pages/09-10ProposedChanges.aspx>.

Note: The following analysis was not in the Code Change monograph but was published on the ICC website at <http://www.iccsafe.org/cs/codes/Documents/2009-10cycle/ProposedChanges/Standards-Analysis.pdf> :

Analysis: Review of proposed new standard SMA MH28.3 indicated that, in the opinion of ICC Staff, the standard did not comply with ICC standards criteria, Section 3.6.3(1) Readily available.

Committee Action:

Disapproved

Committee Reason: The code change includes a definition of the term "industrial steel work platform" which is unclear and is more of a description. It also is included within a provision rather than being listed separately in a definitions section. The proposed reference standard does not appear to allow anything that's not already in the code.

Assembly Action:

None

Individual Consideration Agenda

This item is on the agenda for individual consideration because a public comment was submitted.

Public Comment:

Victor D. Azzi, representing Storage Equipment Manufacturers Association (SMA), requests Approval as Modified by this Public Comment.

Modify proposal as follows:

SECTION 2211 INDUSTRIAL STEEL WORK PLATFORMS

2211.1 General. The design, testing, utilization, application, and maintenance of industrial steel work platforms shall be in accordance with the provisions of ANSI/SMA MH28.3. An industrial steel work platform ~~shall be herein defined as a pre-engineered, prefabricated, elevated platform, employing a steel framing system, located in an industrial environment. Other structural or nonstructural elements shall be permitted for flooring including but not limited to, concrete, steel, and engineered wood products. Personnel working on such platforms are trained employees, accustomed to a manufacturing environment and dressed accordingly.~~

2211.2 Materials. ~~Steel shall be in accordance with the ASTM specifications listed in AISI S100 and AISC 360. Steels not listed in the above specifications are not excluded, provided that they conform to the chemical and mechanical properties of one or more of the listed specifications, or of other specifications which establish their properties and structural suitability, and provided that they are subjected by either the producer or the purchaser to analyses, tests, and other controls to the extent and in the manner prescribed by one of the listed specifications, as applicable.~~

Materials used in the decking structure and surfaces for these work platforms shall be concrete, engineered wood products, plywood or other wood products, steel sheet, steel plate or grating, supported by the steel framing system. Such decking materials shall conform to the applicable provisions of this code and referenced standards appropriate to their use in this application and work environment.

SMA

ANSI MH28.3-098 *Specification for the Design, Manufacture and Installation of Industrial Steel Work-Platforms*

Commenter's Reason: This comment simply eliminates unnecessary language, which was in the original proposal. Please note that the standard is now readily available and, as such, is compliant with ICC rules. Also, the date is corrected from 2008 to 2009; the new edition of this Standard was approved by ANSI on October 27, 2009.

Final Action: AS AM AMPC ____ D
