



International Code Council

Standard on the Design and Construction of Log Structures

ICC 400-2017 edition Public Comment Draft – July 2017

The ICC Consensus Committee on Log Structures has held 2 public meeting to develop this Public Comment Draft of the ICC 400-2017 Standard on the Design and Construction of Log Structures. Public comment is requested on this Public Comment Draft. Please show the proposed NEW or REVISED or DELETED TEXT in legislative format: ~~Line through text to be deleted.~~ Underline text to be added. The public comment deadline is September 11, 2017. Go to <https://www.iccsafe.org/codes-tech-support/codes/code-development-process/standards-development/is-log/> for more information. To purchase a copy of ICC 400-2012 go to [ICC 400-2012](#)

CHAPTER 2 DEFINITIONS

SECTION 202 DEFINED TERMS

BOTTOM PLATE, LOG (STARTER LOG). The first log course in a log wall resting bearing on, and anchored to, the subfloor.

CHECK(ING). A radial crack in the log that occurs as the wood is seasoning; separation of wood cells along the grain as a result of uneven shrinkage (differential tension and compression stresses in the wood structure); a natural ~~and unpredictable~~ result of the seasoning process that generally does not affect the structural integrity of the log.

CONSTRUCTION DOCUMENTS. Written, graphic and pictorial documents prepared or assembled for describing the design, location and physical characteristics of the elements of a project necessary for obtaining a building *permit*. Construction drawings shall be drawn to an appropriate scale.

Involved Height. The vertical height of the portion of a log wall that contributes to each instance of settling, such as but not limited to the rough opening height of a door or a window cutout; the floor to ceiling height at an interior frame wall; the total rise of a staircase; and for a roof, the total height of the log wall.

MEAN ROOF HEIGHT. The average of the roof eave height and the height to the highest point on the roof surface, except that eave height shall be used for roof angle of less than or equal to 10 degrees (0.18 rad).

SILL LOG. A horizontal log bearing on, and anchored to the foundation.

**SECTION 203
SYMBOLS**

MC_S = Service moisture content (Equilibrium Moisture Content)

CHAPTER 3 GENERAL REQUIREMENTS

SECTION 302 MATERIALS

302.2 Logs. Log styles shall include, but are not limited to, round, rectangular or other shapes (profiles) that are peeled, notched, coped, hewn, sawn, milled, or otherwise profiled into their final form for installation.

302.2.3 Design values and section properties. Elements of log structures shall have design values and section properties as prescribed in this section.

~~302.2.3.4 Section Properties.~~

302.2.3.4 Section properties for sawn Round and Unseen Round Timber Beams. Section properties for Sawn Round and Unseen Round Timber Beams shall be in accordance with Table 302.2(2).

302.2.3.5 Section properties for wall Logs. Section properties for Wall Logs shall be in accordance with the prescribed method of Section 302.2.3.5.1 or are permitted to be determined by engineering analysis.

302.2.3.5.1 Prescribed method. Section properties for wall logs shall be determined using the log height and width dimensions of the largest rectangle that can be inscribed with the profile. ~~in accordance with section 302.2.3.5 and 302.2.3.6.~~

Exception: When a square is inscribed within the profile of a round log, the section properties of the inscribed square may be increased by the factors shown in Table 302.2(4).

302.2.3.6 Natural taper. Natural taper shall be permitted in posts and wall logs in excess of the grading rules developed per ASTM D-3957. Section properties for a structural log with natural flared butt shall be determined by the tip diameter or by engineering analysis.

(renumber subsequent sections)

TABLE 302.2(3)—continued
BASE DESIGN VALUES FOR SAWN ROUND AND UNSAWN ROUND TIMBER
BEAMS

(No changes to Table)

For SI: 1 lbf/in² = 6.894 kPa

a. Source Agencies:

1. LHC: Log Home Council, National Association of Home Builders
2. TP: Timber Products Inspection, Inc.

b. The provided design values are to be used only with logs and/or timbers graded and grade marked by the respective grading rules agency or by one of the manufacturers trained, approved and licensed by the grading rules agency to apply grademarks.

c. Compression parallel to the grain values have been increased by 10 percent to account for seasoning. For logs that are unseasoned, the design value for compression parallel to the grain shall be multiplied by 0.91.

d. Values listed represent the typical species or species combination design values. Some species, specie combinations, and/or specie designations are not listed due to limited use. Other species combinations published by accredited grading agencies are permissible.

e. All appropriate adjustment factors shall be applied in accordance with Tables 302.2(4) and 302.2(6).

f. For sawn round timber beams the repetitive member factor, C_r , for bending design values, F_b , shall not apply to sawn round timber beams in any condition or use.

g. Sawn round timber beams shall be installed and protected against end moisture so as to achieve service moisture content ~~equilibrium moisture content in-service~~. Therefore, the Wet Service Factor, C_m , shall not apply.

h. For sawn round timber beams appropriate form adjustment factors, C_f , have already been incorporated in the tabulated design values.

TABLE 302.2(6)
APPLICABILITY OF ADJUSTMENT FACTORS FOR WALL LOGS AND SRTBs

(No changes to Table)

- a. *Load Duration Factor*: Values shown within Tables 302.2(3) and (5) are based upon normal load durations.
- b. *Wet Service Factor*: Logs are to be installed and protected against moisture so as to achieve service moisture content ~~equilibrium moisture content in service~~. Therefore, the Wet Service Factor shall not apply.
- c. *Temperature Factor*: Per ~~AF&PA~~ AWC NDS.
- d. *Beam Stability Factor*: Per ~~AF&PA~~ AWC NDS.
- e. *Size Factor* (~~wall logs SRTB and USRTB~~): Bending design values, F_b , shown within Table 302.2(5) are calculated for an inscribed member width of 12 inches (305 mm). For gravity loads, the vertical dimension of the wall log is the width. For lateral loads, the horizontal dimension of the wall log is the width. The bending design value, F_b , shown with table 302.2(5) shall be multiplied by the size factor,
 $CF = (12/d)^{1/9} < 1.0$,
Where: d = the width of the inscribed rectangle of the wall log relative to the direction of the imposed load being analyzed.
- f. *Size Factor* (~~wall logs SRTB and USRTB~~): Bending design values, F_b , shown within Table 302.2(3) are calculated for a 2" x 2" (51 mm x 51 mm). Currently ASTM D 3957 does not explicitly require a size reduction for SRTB values. However, this is commonly performed within the industry and the applicability of this factor is at the designer's discretion. Should a size reduction be necessary, the bending design value, F_b , show within Table 302.2(3) shall be multiplied by the size factor,
 $CF = (2.2568/d)^{1/9}$,
Where: d = log diameter
- g. *Flat Use Factor*: Not applicable for any use of wall logs or sawn round timbers.
- h. *Incising Factor*: Per ~~AF&PA~~ AWC NDS.
- i. *Repetitive Member Factor*: Not applicable for any use of wall logs or sawn round timbers.
- j. *Buckling Stiffness Factor*: Not applicable for any use of wall logs or sawn round timbers.
- k. *Column Stability Factor*: Per ~~AF&PA~~ AWC NDS.

302.2.3.5 Log stack height. For calculation purposes, the log stack height in inches (H_L) shall equal the average vertical dimension of the log at time of manufacture as described in Figure 302.2.3.6 as follows:

1. For logs profiled with horizontal bearing surfaces, H_L is the dimension between bearing surfaces.
2. For all other log profiles, the manufacturer shall provide the dimension for H_L .

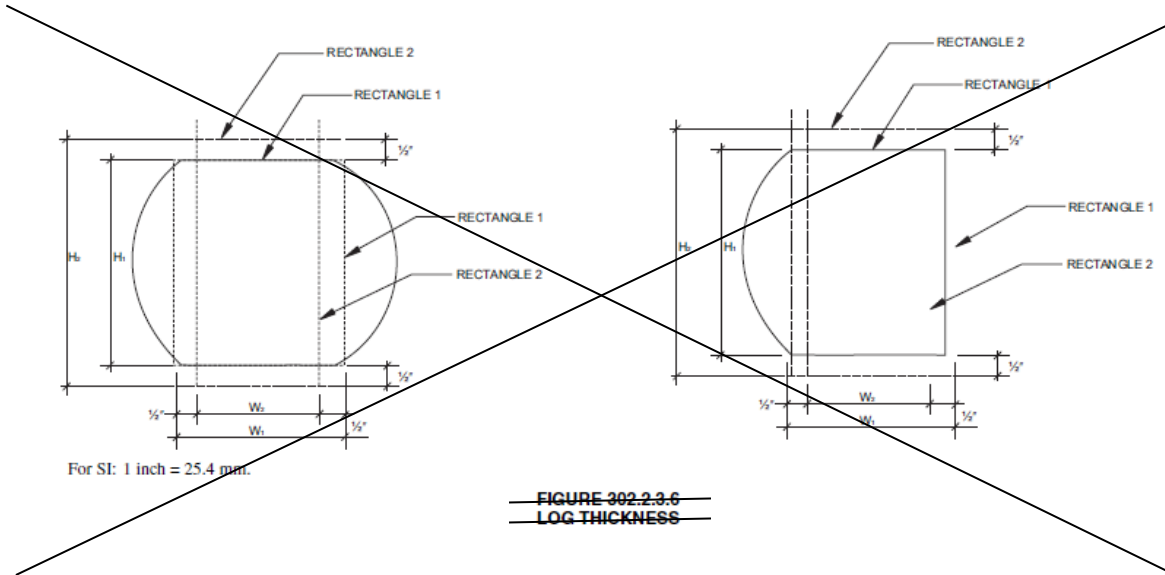

302.2.4 Notching and boring. Notching and boring of logs used in structural applications shall be in accordance with this section and Figure 302.2.4.

302.2.4.2 Interlocking log notches. Interlocking log notches shall resist the lateral separation of the two log members joined at joints, or the two log members shall be joined with have mechanical fasteners that resist separation.

d = depth of log at location of notch or hole measured perpendicular to the direction of the hole or notch.
 l_n = length of notch
 D_r = diameter of round hole
 D_s = depth of rectangular hole
 W_s = width of rectangular hole
 L = clear span of bending member

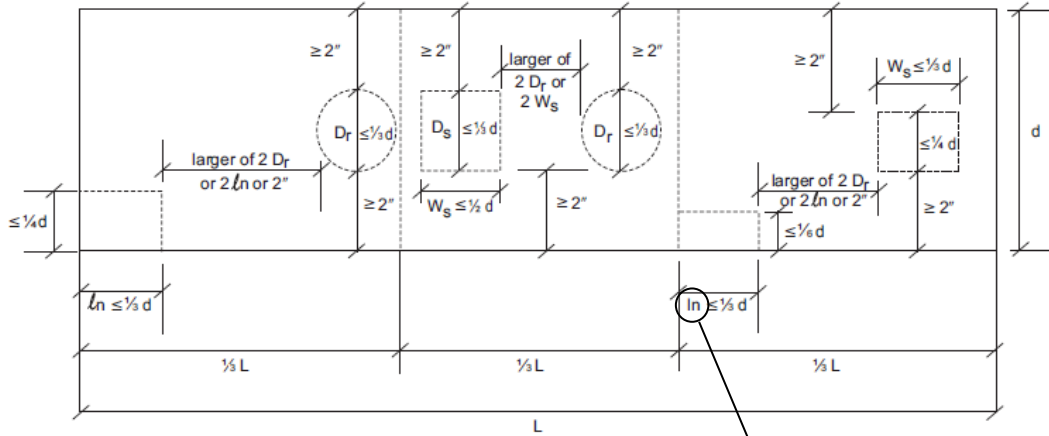

For SI: 1 inch = 25.4 mm.

FIGURE 302.2.4
NOTCHING AND BORING

l_n

302.2.5 Wood treatments. Use of wood treatments shall comply with the requirements of this section.

302.2.5.2 Logs required to be preservative treated. Logs required by the applicable code to be preservative treated shall be treated using processes and preservatives in accordance with AWPA Standards and AWPA Use Categories and shall bear the quality mark or certificate of treatment issued by an accredited third party agency.

302.4 Roof overhangs. (renumbered and relocated; see Section 306.2.5)

**SECTION 303
FIRE-RESISTANCE RATINGS OF LOGS AND LOG
ASSEMBLIES**

303.1 Fire resistance. Fire resistance of logs and log assemblies shall be in accordance with the provisions of this section.

303.1.1 ~~303.4~~ Log thickness. For the purposes of Section 303, the log thickness shall be the smallest horizontal dimension from the outside face to the inside face of the log wall. Sealant systems shall not be included in determining the log thickness unless the sealant system is fire-resistance-rated ~~resistive-rated~~.

303.1.2 ~~303.5~~ Sealing system. Sealant systems used to protect joints as part of the fire- resistance-rated ~~resistive-rated~~ assembly shall be in accordance with the requirements of either ASTM E 1966 or UL 2079.

(renumber subsequent sections as follows)

303.4 ~~303.6~~ Fire blocking.

303.5 ~~303.7~~ Fastener protection.

303.6 ~~303.8~~ Penetrations.

303.6.1 ~~303.8.1~~ Fire-resistance-rated assemblies.

303.6.2 ~~303.8.2~~ Through-penetration fireblocking system.

SECTION 304 PROVISIONS FOR SETTLING IN LOG STRUCTURES

304.2 Determining total settling. Total settling shall be determined by the provisions of either Section 304.2.1, 304.2.2, 304.2.3, 304.2.4 or 304.2.5.

304.2.1 Prescriptive requirement: Total settling shall be ~~equal to or greater than~~ taken as 6 percent of the involved height.

304.2.2.1 Settling due to slumping. Settling due to slumping (Δ_{SL}) shall be in accordance with the requirements of this section.

304.2.2.1.1 Prescribed slumping. Prescribed slumping shall be 3/16 inch (~~1.5 percent~~) per foot (4.8 mm per ~~304~~ 305 mm) (1.5 percent) of involved log wall height.

~~**304.2.2.1.2.3 Noncontact.** Where logs are separated by bearing devices and joinery such that contact between logs is prevented.~~

304.2.2.1.2.3 Chink spaces. Settling due to slumping (Δ) shall be permitted to be taken as 0 where bearing devices (blocks) keep wall logs separated within a lengthwise space. Lengthwise spaces that have non-continuous copes shall be in accordance with 304.2.2.1.2.2.

304.2.2.1.2.4 Noncontact and nonsettling. Settling due to slumping (Δ_{SL}) shall be permitted to be taken as 0 where wall logs are held apart by engineered devices that prevent log-to-log contact lengthwise, and prevent settling.

304.2.2.2.2 Noncompaction conditions. = 0 when ~~$B = B_f$~~ $B \geq B_f$

304.2.2.3 Settling due to dimensional change. Settling of log walls due to shrinkage (dimensional change in cross-section, Δ_S) shall be determined in accordance with one of the provisions of this section.

304.2.2.3.1 Prescribed, Method A. Prescribed shrinkage (Δ_S) shall be 3/8 inch (~~3 percent~~) per foot (9.5 mm per 305 mm) (3 percent) of involved log wall height.

304.2.2.3.2 Prescribed, Method B. Prescribed shrinkage (Δ_S) shall be 1 percent change in dimension of involved wall height per 4 percent change in moisture content (~~$MC_S - MC_D$~~ $MC_D - MC_S$) per foot of involved log wall height.

304.2.2.3.3 Prescribed, Method C. Select prescribed shrinkage (Δ_S) from Table 304.2(4) by climate zone, initial design moisture content (MC_D) (MA), and shrinkage coefficient. Refer to the Climate Zone Map included in Figure 304.2.2.3 for a representation of geographic variation in outside service moisture content ~~equilibrium moisture content~~.

**TABLE 304.2(4)
PRESCRIBED SETTLING ALLOWANCE DUE TO SHRINKAGE**

	Service Moisture Content (MCS)	Radial Shrinkage Coefficient = 2.5 for Cedar, Redwood			Radial Shrinkage Coefficient = 4 for White Woods			Radial Shrinkage Coefficient = 4.7 for Oak, Maple			
		$MC_D = 19\%$ MC	$MC_D = 23\%$ MC	$MC_D = 30\%$ MC	$MC_D = 19\%$ MC	$MC_D = 23\%$ MC	$MC_D = 30\%$ MC	$MC_D = 19\%$ MC	$MC_D = 23\%$ MC	$MC_D = 30\%$ MC	
Climate Zone ^c	Dry	Ranging from 8% to 13%; averaging 10%	$3/32$ -in. per ft. or 0.8% of involved height	$1/8$ -in. per ft. or 1% of involved height	$13/64$ -in. per ft. or 1.7% of involved height	$9/64$ -in. per ft. or 1.2% of involved height	$13/64$ -in. per ft. or 1.7% of involved height	$5/16$ -in. per ft. or 2.6% of involved height	$11/64$ -in. per ft. or 1.4% of involved height	$1/4$ -in. per ft. or 2.1% of involved height	$3/8$ -in. per ft. or 3.1% of involved height
	Moist	Ranging from 12% to 15%; averaging 13%	$1/16$ -in. per ft. or 0.5% of involved height	$3/32$ -in. per ft. or 0.8% of involved height	$11/64$ -in. per ft. or 1.4% of involved height	$3/32$ -in. per ft. or 0.8% of involved height	$5/32$ -in. per ft. or 1.3% of involved height	$17/64$ -in. per ft. or 2.2% of involved height	$7/64$ -in. per ft. or 0.9% of involved height	$3/16$ -in. per ft. or 1.6% of involved height	$5/16$ -in. per ft. or 2.6% of involved height
	Warm-Humid	Ranging from 13% to 15%; averaging 14%	$3/64$ -in. per ft. or 0.4% of involved height	$3/32$ -in. per ft. or 0.8% of involved height	$5/32$ -in. per ft. or 1.3% of involved height	$5/64$ -in. per ft. or 0.7% of involved height	$9/64$ -in. per ft. or 1.2% of involved height	$1/4$ -in. per ft. or 2.1% of involved height	$3/32$ -in. per ft. or 0.8% of involved height	$11/64$ -in. per ft. or 1.4% of involved height	$19/64$ -in. per ft. or 2.5% of involved height
	Marine	Ranging from 13% to 17%; averaging 15%	$3/64$ -in. per ft. or 0.4% of involved height	$5/64$ -in. per ft. or 0.7% of involved height	$5/32$ -in. per ft. or 1.3% of involved height	$1/16$ -in. per ft. or 0.5% of involved height	$1/8$ -in. per ft. or 1% of involved height	$15/64$ -in. per ft. or 2% of involved height	$5/64$ -in. per ft. or 0.7% of involved height	$5/32$ -in. per ft. or 1.3% of involved height	$9/32$ -in. per ft. or 2.3% of involved height

Notes to Table 304.2(4):

(no change to footnotes 1 and 2)

3. Within a Radial Shrinkage Coefficient group, choose a column associated with the appropriate MC_D : 19%, or 23%, or 30%.

(renumber subsequent footnotes)

TABLE 304.2(2)
SHRINKAGE COEFFICIENTS
 (portions of table not shown remain unchanged)

Shrinkage* (%) from green to oven-dry moisture content		
Species	Radial	Tangential
Softwoods		
Baldcypress	3.8	6.2
Cedar		
Alaska	2.8	6.0
Atlantic white	2.9	5.4
Eastern <u>red cedar</u>	3.1	4.7
Incense	3.3	5.2
Northern white	2.2	4.9
Port-Orford	4.6	6.9
Western <u>red cedar</u>	2.4	5.0
Douglas-fir		
Coast ^b	4.8	7.6
Interior north ^b	3.8	6.9
Interior west ^b	4.8	7.5
Fir		
Balsam	2.9	6.9
California red	4.5	7.9
Grand	3.4	7.5
Nobel	4.3	8.3
Pacific silver	4.4	9.2
Subalpine	2.6	7.4
White	3.3	7.0
Hemlock		
Eastern	3.0	6.8
Western	4.2	7.8
Larch, western	4.5	9.1
Pine		
<u>Eastern pine</u>	2.1	6.1
Jack	3.7	6.6
Lodgepole	4.3	6.7
Ponderosa	3.9	6.2
Red		

304.2.2.3 Settling due to dimensional change. Settling of log walls due to shrinkage (dimensional change in cross-section, Δ_s) shall be determined in accordance with the provisions of this section.

304.2.2.3.3 Prescribed, Method C. Select prescribed shrinkage (Δ_s) from Table 304.2(4) by climate zone, initial moisture content (M_i), and shrinkage coefficient. Refer to the Climate Zone Map included in Figure 304.2.2.3 for a

representation of geographic variation in outside service moisture content
~~equilibrium moisture content.~~

304.3 Accommodating settling. Log structures shall accommodate ~~calculated~~ settling in accordance with this section. ~~Calculated~~ The settling accommodation shall ~~calculated~~ and be stated in the construction documents for each ~~location~~ occurrence of involved settling height. The required settling allowance at each occurrence of settling is calculated as equal to Δt (total settling) times the involved height at this occurrence.

Exception: Log wall systems where Δt is less than or equal to 0.5 percent of the involved settling height (H_D) to Δt is a maximum of 1/2 inch (12.7 mm).

304.3.1 Settling space gap. ~~The~~ There shall be a settling space gap ~~must that~~ accommodates the involved settling height of all materials as they settle. Trim or other measures used to conceal settling spaces ~~gaps~~ in walls shall be treated as sliding joints.

304.3.2 Sliding joint. Vertical joints shall accommodate ~~not restrict~~ settling at log wall interface. ~~Examples include but are not limited to the buck system installed at the sides of log wall openings, frame-wall intersections, cabinet installation, trim application, fireplaces and chimneys.~~

304.3.3 Settling devices. At point loads, such as at posts or columns, an engineered, adjustable and accessible device shall be used to accommodate the involved settling height at point loads. ~~Examples include and are not limited to support posts and horizontal structural framing member to non-settling structures.~~

304.3.5 Counter-flashing. Counter-flashing shall be installed at all penetrations of the building exterior where necessary to allow appropriate movement due to settling.

304.3.6 Fasteners/connections. Installation of fasteners and connections shall conform to the requirements of this section.

304.3.6.2 Dowel-type fasteners installed vertically. Dowel-type fasteners shall be installed with the length vertical within the wall to accommodate settling. ~~Where a fastener is installed vertically [plus or minus 5 degrees (0.0875 rad) from vertical] within the wall, it shall accommodate settling.~~

Exception: Wall systems fastened in such a way that the fastening system holds each log at or close to its original elevation in the wall as the logs dry to service moisture content ~~equilibrium moisture content.~~

304.3.6.3 Fasteners installed horizontally. Fasteners installed horizontally ~~through a log wall that~~ to attach non-settling abutments to the log wall shall be

installed with an oversized washer under the head of the fastener and located near the top of an oversized vertically slotted hole such that the involved settling at that location is accommodated. The washer shall be able to turn under the fastener head. The resulting connection shall be in compliance with Section 404.

304.3.7.2 Pipes through log walls. A plumbing pipe shall only travel through a log wall perpendicular to the long horizontal axis of the logs, shall be level or nearly level, and shall be fitted with flexible connections at each end or be provided with a sufficient settling ~~gap~~ space to accommodate the involved setting height.

**SECTION 305
THERMAL ENVELOPE**

305.1 Weather protection. Exterior walls shall comply with the applicable code and the provisions of this section.

305.1.1 Joint design. Joint design and applied sealants shall be capable of maintaining the weather seal between logs in exterior walls as individual logs reach service moisture content ~~equilibrium moisture content~~.

305.1.2 Moisture control and air leakage. The joint design shall resist air and moisture infiltration.

**TABLE 305.3.1.1
U-Factor of Log Wall (U_w) by ~~Average Width~~ Log Thickness (W_L) and Specific Gravity**

Specific Gravity (G_u)	<u>Average Width</u> <u>Log Thickness</u>
--	--

(No changes to the remainder of the Table)

305.4 Thermal mass effect of log walls. The thermal mass benefit of log walls shall be determined in accordance with this section.

305.4.3 Calculation method for computer modeling.

305.4.3.1 Weight of wall. Calculate the weight of the wall in pounds per square foot (psf) ~~using the density equation in Section 302.2.3.7 in accordance with~~ Section 302.2.3.8 using the service moisture content (MC_s) in place of design (MC_D) moisture content.

305.4.3.2 Heat capacity. Calculate the heat capacity for the thermal mass provision using the following.

$$HC = w \times c$$

where:

HC = Heat capacity of the exterior wall, Btu/ft² × °F [kJ/(m² × K)] of exterior wall area.

w = Mass of the exterior wall, lb/ft² (kg/m²) of exterior wall area is the density of the exterior wall material, lb/ft³ (kg/m³) multiplied by ~~the thickness of the exterior~~

~~wall calculated in accordance with section~~ log thickness (WL) in accordance with Section 302.2.3.6.

c = Specific heat of the exterior wall material, Btu/lb × °F [kJ / (kg × K)] of exterior wall area as determined from Table 305.4.1.3. The moisture content references in Table 305.4.1.3 shall be selected to be less than or equal to MCs.

~~305.4.3.2 Determine the mass U_w .~~ Referring to IECC Table 502.2.1.1.2(3), ~~select the column by matching the U_w determined in Section 305.4.2.1 to those heading the columns. Select the row according to the design heating degree days. Where the column and row cross provides the U_w with thermal mass effect.~~

SECTION 306 INFILTRATION

306.1 Log Walls. Log walls shall comply with this Section.

306.1.1 Air Leakage. The building thermal envelope shall comply with Sections 306.1.1.1 through 306.1.1.4.

306.1.1.3 Structural components passing over or through log walls. Where structural roof or floor members pass beyond the weather protection provided by the joint design, the penetration shall be capable of maintaining the weather seal between wall and structural members as the logs reach service moisture content equilibrium moisture content.

306.1.1.4 Wall Openings. Rough openings in walls shall be designed and constructed to protect the opening from air ~~and water~~ infiltration as well as accommodate settling.

306.1.1.5 Sill Logs and Bottom Plate Logs. Below sill logs and bottom plate logs there shall be a continuous air sealant that is capable of maintaining the weather seal.

306.2 Moisture Protection. The exterior water plane shall effectively shed water from precipitation and shall comply with Sections 306.2.1 through 306.2.7 ~~306.2.4~~.

306.2.1 Water plane. The exterior water plane is formed by the contiguous log surfaces on which a water film may form extending to the point of weather protection provided by joint design in accordance with Section 305.1.

306.2.2 Water collection. Wall surfaces shall be designed and constructed to promote positive drain of water to exterior to eliminate potential for collection of moisture on or in the log wall.

306.2.2.1 Seams and joints. Seams and joints occurring in the log surface shall not interrupt the water plane.

306.2.3 Wall penetrations and joints. ~~All penetrations of~~ The log wall shall be protected by roof overhang, flashing or other method to divert water away from the seams, joints, and bottom edges of penetrations, chink and settling spaces. Such protection shall be capable of maintaining the weather seal between wall and structural members as the logs reach service moisture content.

306.2.4 Protective treatments. Wood treatment shall be applied to log surfaces in accordance with manufacturer's instructions specific to the condition of the logs (e.g., green, dry, weathered). Treatments shall be selected and applied to ensure

that moisture drawn from within the log to the log surface will not be trapped against an impervious film.

306.2.5 ~~302.4~~ Roof overhangs. Roof overhangs shall extend horizontally a minimum of OH/8, but not less than 12 inches (305 mm), beyond the lowest exposed wall surface, where OH is the wall height measured from the bottom of the sill log or bottom plate or from a projection from the exterior of the log wall such as a porch roof, balcony, deck, or any individual log member. The extension of the roof overhang shall be measured horizontally from the face of the exterior wall to the drip line at the edge of the overhang.

Exceptions: Roof overhangs shall be permitted to be a minimum of 12 inches (305 mm), regardless of the wall height where any of the following conditions apply:

1. Logs within 24 inches (610 mm) of a lower horizontal surface such as the finished grade, a bulkhead cover, deck, balcony or roof are treated in compliance with Section 302.2.5.
2. A gutter and downspout or other means are used to divert roof water discharge and the bottom of the sill log or bottom plate log is at least 18 inches (457 mm) above an adjacent horizontal surface.
3. Decks adjacent to the log wall have structural grating or other means to deter backsplash equal in width to the overhang to allow water to pass unimpeded to the finished grade.

306.2.6 Flashing. Where roof logs, floor logs, or log posts are not protected by roof overhang, and are exposed to weather they shall be flashed to shed water and prevent water from passing through the exterior water plane. Approved corrosion-resistant flashings shall be installed at all of the following locations in a manner to prevent entry of water, and to protect structural members:

1. Continuously above all exterior window or door openings in accordance with the fenestration manufacturer's installation and flashing instructions, the flashing design of a registered design professional or other approved methods.
2. Continuously above all wood trim that projects beyond the water plane.
3. Continuously on top of all exterior floor, balcony, or deck structural members.
4. Continuously on top of all exterior roof members where they project beyond the roof drip edge.
5. Continuously at the interface of the log wall and the non-log wall above.
6. Continuously below the sill log or bottom plate log.

306.2.7 Wall Openings. Rough openings in walls shall be designed and constructed to protect the opening from water infiltration as well as accommodate calculated settling.

CHAPTER 4 STRUCTURAL PROVISIONS

SECTION 402 PRESCRIPTIVE PROVISIONS

402.1 Prescriptive provisions. Log structures ~~not requiring engineering design in accordance with~~ constructed within the limitations established by Section 403 shall not require engineering ~~be permitted to use prescriptive provisions as approved by the building official.~~

SECTION 403 ENGINEERED PROVISIONS

403.1 Applicability. If the building geometry, or loads related to the log structure, exceed any of the following limitations, then the building shall be designed using the provisions of Sections 403 through 407. If portions of building geometry, or loads related to those portions, exceed any of the following limitations, then the affected portions shall be designed using the provisions of Sections 403 through 407. The limitations are:

(no change to items 1 and 2)

3. Log floor systems

d. Log floor joist cantilevers ~~supporting non-load-bearing walls which are not shear walls~~ greater than one-quarter of the span, $L/4$, that support non-load-bearing walls which are not shear walls.

4. Log walls

- a. Load bearing and non-load-bearing log walls greater than 20 feet (6.1 m) in unsupported height.
- b. Offsets greater than 4 feet (1219 mm) in a log shear wall line within a story ~~greater than 4 feet (1219 mm)~~.
- c. Upper story log shear wall segments offset from lower story log shear wall segments by more than the depth, d , of the log floor framing members.
- d. Log shear wall segment aspect ratios greater than 1:1 ($h:l$).
- e. Log shear wall lines oriented to resist loads in two orthogonal directions.

(no changes to remainder of items)

SECTION 404 CONNECTIONS

404.6 Special connections. Consideration shall be given to special connections as addressed in this section.

404.6.4 Uplift Loads on exterior log wall assemblies. Log walls that support log rake overhang purlins (outlookers, or lookout blocks) shall be designed to resist ~~the uplift~~ all calculated loads. Log walls that do not support the roof assembly need only resist the uplift load.

404.6.7 Log rake overhang purlins ~~outlookers~~. Connections of log rake overhang purlins (outlookers) to the gable end wall shall be designed to resist the calculated uplift loads

SECTION 405 FLOOR SYSTEMS

405.8 Floor openings. Framing around floor openings shall be designed to transfer loads to adjacent framing members that are designed to support the additional concentrated loads. Fasteners, connections, and stiffeners shall be designed for the loading conditions. Where the edge of the opening is less than 2 feet (610 mm) from an bearing exterior wall, the bearing exterior wall adjacent to the opening shall be designed to resist applicable gravity, lateral, and uplift loads at that location.

405.9 Sheathing and decking spans. Floors shall be ~~fully~~ sheathed with materials capable of resisting and transferring the applied gravity loads to the floor framing members.

405.11 Floor diaphragm bracing. Framing and connections shall be designed, to transfer the lateral wind loads from the exterior wall to the floor diaphragm assembly ~~in accordance with the calculated loads~~.

SECTION 406 LOG WALLS

406.1 Load resistance. Log walls shall be designed to resist wind and seismic loads, gravity loads, and uplift loads in accordance with applicable load standards. ~~The maximum shear wall aspect ratio shall be 1:1 for walls used in the design of shear walls to resist wind and seismic loads.~~

406.2 Corners and intersecting log walls. At corners and intersection log walls, logs shall be connected by mechanical fastening or interlocking joinery at corners, and intersecting walls and beams to shall resist and transfer applicable lateral loads to the roof or floor diaphragm. Wall logs shall be continuous within a single course between openings, or have designed fastening at splices between logs to resist lateral loading.

406.2.1 Logs between openings. To resist lateral loading, wall logs between openings shall be continuous within a single course, or shall have fasteners at the splices that join non-continuous logs.

406.5 Window sill log. Window sill logs shall be designed to resist lateral loads. Window sill logs shall be continuous and shall extend beyond the edge of the window opening to provide connection to the wall assembly equal to or greater than the length of the header log.

SECTION 407 ROOF SYSTEMS

407.6 Rake overhangs. Log rake overhang purlins (outlookers), used as framing members shall use continuous purlins designed to be structural cantilevers and shall be connected in accordance with Section 404.6.7.