

Chapter 3. Building Blocks

301 General

301.1 Scope. The provisions of Chapter 3 shall apply where required by the scoping provisions adopted by the administrative authority or by Chapters 4 through 11.

301.2 Overlap. Unless otherwise specified, clear floor spaces, clearances at fixtures, maneuvering clearances at doors, and turning spaces shall be permitted to overlap.

302 Floor Surfaces

302.1 General. Floor surfaces shall be stable, firm, and slip resistant, and shall comply with Section 302. Changes in level in floor surfaces shall comply with Section 303.

302.2 Carpet. Carpet or carpet tile shall be securely attached and shall have a firm cushion, pad, or backing or no cushion or pad. Carpet or carpet tile shall have a level loop, textured loop, level cut pile, or level cut/uncut pile texture. The pile shall be $\frac{1}{2}$ inch (13 mm) maximum in height. Exposed edges of carpet shall be fastened to the floor and shall have trim along the entire length of the exposed edge. Carpet edge trim shall comply with Section 303.

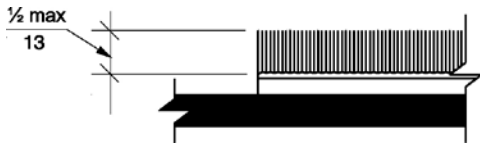

Figure 302.2 Carpet on floor surface

302.3 Openings. Openings in floor surfaces shall be of a size that does not permit the passage of a $\frac{1}{2}$ inch (13 mm) diameter sphere, except as allowed in Sections 407.4.3, 408.4.3, 409.4.3, 410.4, and 805.10. Elongated openings shall be placed so that the long dimension is perpendicular to the predominant direction of travel.

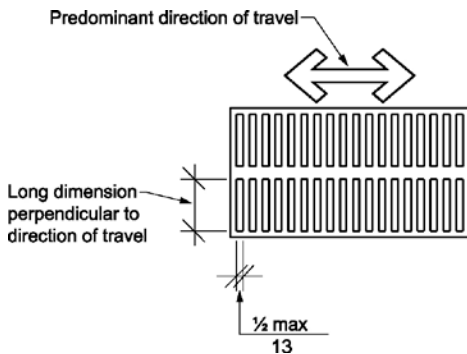

Figure 302.3 Openings in floor surface

303 Changes in Level

303.1 General. Changes in level in floor surfaces shall comply with Section 303.

303.2 Vertical. Changes in level of 1/4 inch (6.4 mm) maximum in height shall be permitted to be vertical.

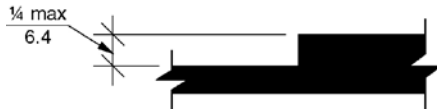

Figure 303.2 Vertical Change in level

303.3 Beveled. Changes in level greater than 1/4 inch (6.4 mm) in height and not more than 1/2 inch (13 mm) maximum in height shall be beveled with a slope not steeper than 1:2. (3-4-12 PC4/PC5)

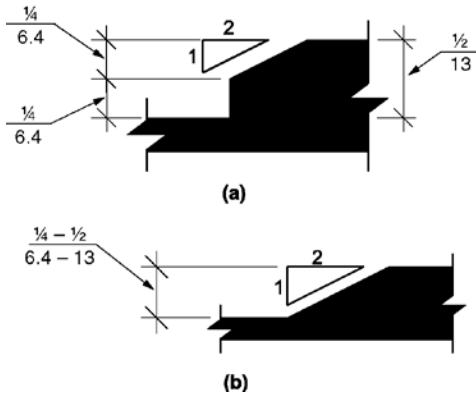

Figure 303.3 (a) & (b) Beveled change in level

303.4 Ramps. Changes in level greater than 1/2 inch (13 mm) in height shall be ramped and shall comply with Section 405 or 406.

304 Turning Space

304.1 General. A turning space shall comply with Section 304.

304.2 Floor Surface. Floor surfaces of a turning space shall comply with Section 302. Changes in level ~~are~~ shall not be permitted within the turning space.

EXCEPTION: Slopes not steeper than 1:48 shall be permitted. (3-5-12)

(Note: Editorial #59 – good code language)

304.3 Size. Turning spaces shall comply with Section 304.3.1 or 304.3.2.

304.3.1 Circular Space.

304.3.1.1 New buildings. In new buildings, The turning space shall be a circular space with a 67 inch (1700 mm) minimum diameter. The turning space shall be permitted to include knee and toe clearance complying with Section 306. Where the turning space includes knee and toe clearances under an obstruction, the overlap shall comply with all of the following: . (3-6-12) (3-8-12)

1. The depth of the overlap shall not be more than 10 inches (255 mm), and
2. The depth shall not exceed the depth of the knee and toe clearances provided, and
3. The overlap shall be permitted only within the turning circle area shown shaded in Figure 304.3.1.

(3-8-12)

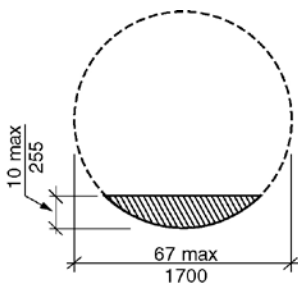

Overlap of knee and toe clearance

Figure 304.3.1.1 Circular turning space – new buildings – size and overlap

304.3.1.2 Existing buildings. In existing buildings, the turning space shall be a circular space with a 60 inch (1525 mm) minimum diameter. The turning space shall be permitted to include knee and toe clearance complying with Section 306. (3-6-12 PC2)

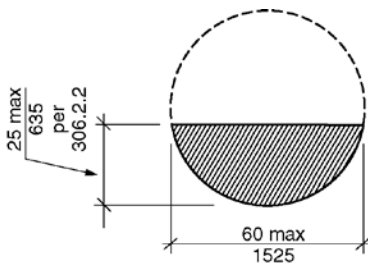

Overlap of knee and toe clearance

Figure 304.3.1.2 Circular turning space – existing buildings – size and overlap

304.3.2 T-Shaped Space.

****304.3.2.1 New construction building.** In new buildings, The turning space shall be a T-shaped space complying with one of the following:

1. A T-shaped space, clear of obstruction, that fits within an area 68 inches (1725 mm) wide and 60 inches (1525 mm) deep, with two arms and one base that are all 36 inches (915 mm) minimum in width. Each arm shall extend 16 inches (405 mm) minimum from each side of the base located opposite the other, and the base shall extend 24 inches (610 mm) minimum from the arms. At the intersection of each arm and the base, the interior corners shall be chamfered for 8 inches (205 mm) minimum along both the arm and along the base.
2. A T-shaped space, clear of obstruction, that fits within an area 64 inches (1625 mm) wide and 60 inches (1525 mm) deep, with two arms 38 inches (965 mm) minimum in width and a base 42 inches (1065 mm) minimum in width. Each arm shall extend 11 inches (280 mm) minimum from each side of the base, located opposite the other, and the base shall extend 22 inches (560 mm) minimum from each arm.
3. A T-shaped space, clear of obstruction, 64 inches (1625 mm) wide and 60 inches (1525 mm) deep, with two arms and one base 40 inches (1015 mm) minimum in width. Each arm shall extend ~~be~~ 12 inches (305 mm) minimum from each side of the base and the base shall extend 20

inches (510 mm) minimum from each arm. (3-9-12)(3-9-12 PC3)

(Note: match format for new and existing – always building)

Exception: The turning space shall be permitted to include knee and toe clearance complying with Section 306 only at the end of either the base or one arm. (3-9-12 PC3)

(note: This is a limitation for overlap, not an exception. Remove 'exception' to be consistent with circular turning space and T-shaped in existing buildings)

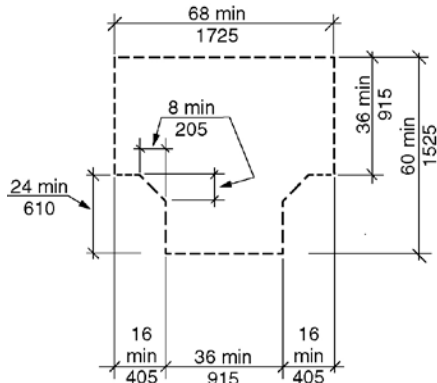

Figure 304.3.2.1(a) T-shaped turning space- new buildings - Option 1

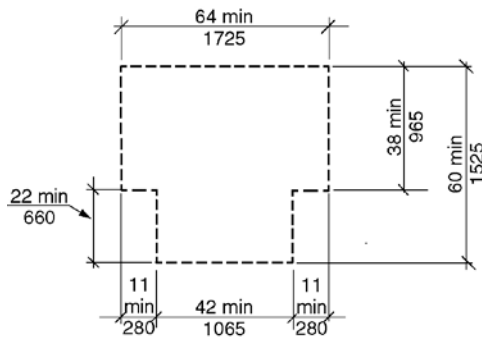

Figure 304.3.2.1(b) T-shaped turning space- new buildings - Option 2

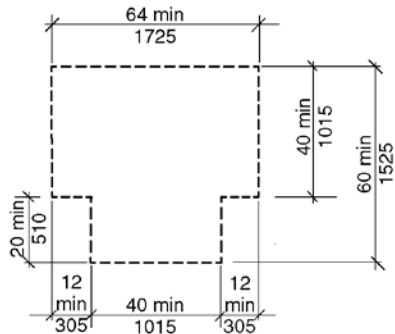

Figure 304.3.2.1(c) T-shaped turning space- new buildings - Option 3

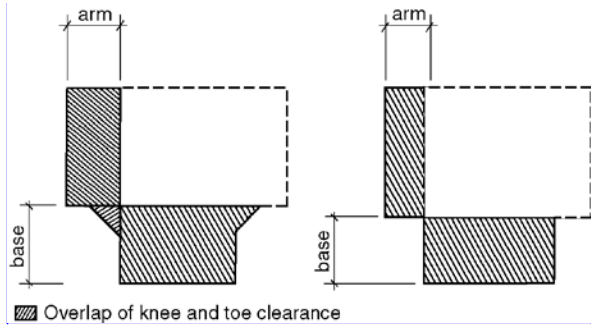

Figure 304.3.2.1(d) T-shaped turning space- new buildings - Overlap

Comment [KR1]: Drawing being revised

304.3.2.2 Existing buildings. In existing buildings, the turning space shall be a T-shaped space within a 60-inch (1525 mm) minimum square, with arms and base 36 inches (915 mm) minimum in width. Each arm of the T shall be clear of obstructions 12 inches (305 mm) minimum in each direction, and the base shall be clear of obstructions 24 inches (610 mm) minimum. The turning space shall be permitted to include knee and toe clearance complying with Section 306 only at the end of either the base or one arm. (3-6-12 PC2)

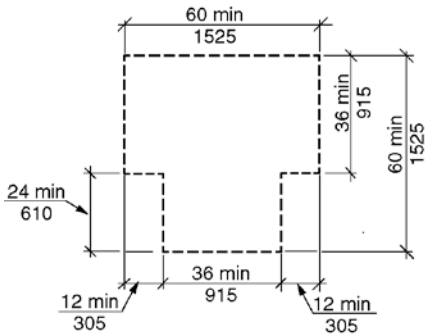

Figure 304.3.2.2(a) T-shaped turning space – existing buildings – size

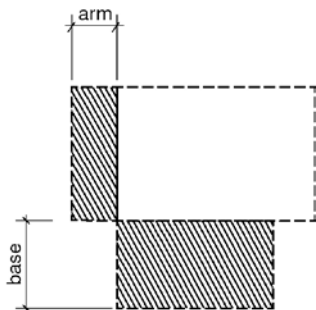

Figure 304.3.2.2(b) T-shaped turning space – existing buildings – overlap

304.4 Door Swing. Unless otherwise specified, doors shall be permitted to swing into turning spaces.

305 Clear Floor Space

305.1 General. A clear floor space shall comply with Section 305.

305.2 Floor Surfaces. Floor surfaces of a clear floor space shall comply with Section 302. Changes in level ~~are~~ shall not be permitted within the clear floor space.

EXCEPTION: Slopes not steeper than 1:48 shall be permitted. (3-5-12)
(Note: Editorial #59 – good code language)

305.3 Size.

305.3.1 New buildings. In new buildings, the clear floor space shall be 52 inches (1320 mm) minimum in length and 30 inches (760 mm) minimum in width. (3-13-12)

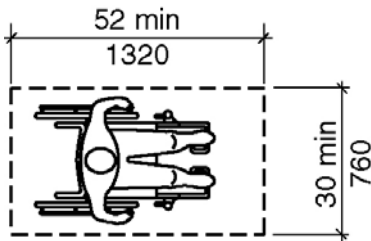

Figure 305.3.1 - Size of clear floor space – new building

****305.3.2 Existing buildings and within new Type B units.** In existing construction buildings and within new Type B units, the clear floor space shall be 48 inches (1220 mm) minimum in length and 30 inches (760 mm) minimum in width. (3-6-12 PC2)
(Note: Already addressed for Type B in 1104.1.1; change 'construction' to be consistent with exception throughout document)

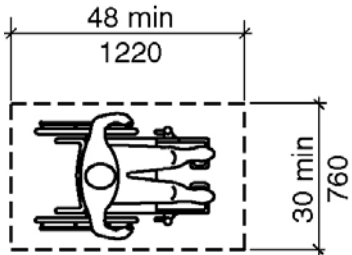

Figure 305.3.2 - Size of clear floor space – existing building

305.4 Knee and Toe Clearance. Unless otherwise specified, clear floor space shall be permitted to include knee and toe clearance complying with Section 306.

305.5 Position. Unless otherwise specified, the clear floor space shall be positioned for either forward or parallel approach to an element.

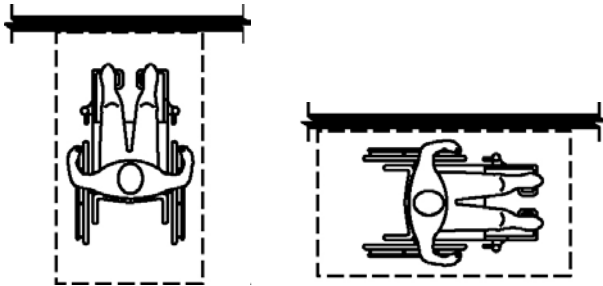

Figure 305.5 Position of clear floor space
a) forward
b) parallel

305.6 Approach. One full, unobstructed side of the clear floor space shall adjoin or overlap an accessible route or adjoin another clear floor space.

305.7 Alcoves. If a clear floor space is in an alcove or otherwise confined on all or part of three sides, additional maneuvering clearances complying with Sections 305.7.1 and 305.7.2 shall be provided, as applicable.

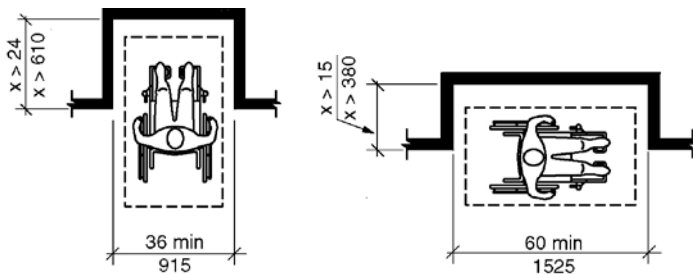

Figure 305.7 Maneuvering clearance in an alcove
a) forward approach
b) parallel approach

305.7.1 Parallel Approach. Where the clear floor space is positioned for a parallel approach, the alcove shall be 60 inches (1525 mm) minimum in width where the depth exceeds 15 inches (380 mm).

****305.7.2 Forward Approach.**

Where the clear floor space is positioned for a forward approach, the alcove shall be 36 inches (915 mm) minimum in width where the depth exceeds 24 inches (610 mm) (3-13-12 PC4.1)

305.8 Seat Back Location. For the purposes of this standard, the seat back of a wheelchair within the clear floor space shall be considered 40 inches (1015 mm) from the front or 12 inches (305 mm) from the rear of a wheelchair space (6-46-12/21/PC2.1- Agenda Item #25.1)

306 Knee and Toe Clearance

306.1 General. Where space beneath an element is included as part of clear floor space at an element, clearance at an element, or a turning space, the space shall comply with Section 306. Additional space shall not be prohibited beneath an element, but shall not be considered as part of the clear floor space or turning space.

306.2 Toe Clearance.

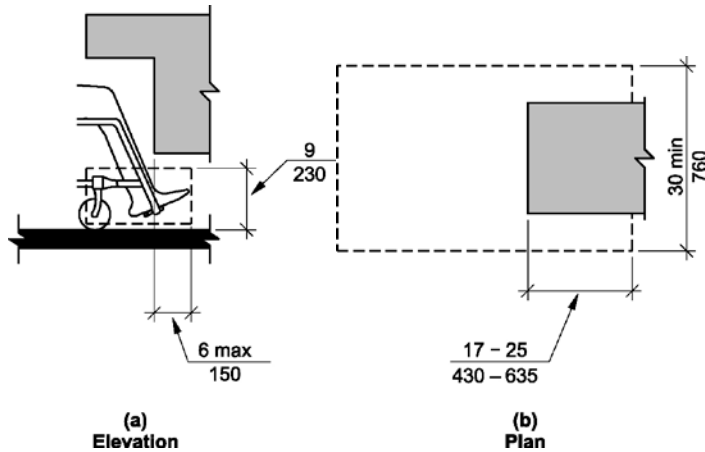

Figure 306.2 – Toe clearance

a) elevation

b) plan

306.2.1 General. Space beneath an element between the floor and 9 inches (230 mm) above the floor shall be considered toe clearance and shall comply with Section 306.2.

306.2.2 Maximum Depth. Toe clearance shall be permitted to extend 25 inches (635 mm) maximum under an element.

306.2.3 Minimum Depth. Where toe clearance is required at an element as part of a clear floor space complying with Section 305, the toe clearance shall extend 17 inches (430 mm) minimum beneath the element.

306.2.4 Additional Clearance. Space extending greater than 6 inches (150 mm) beyond the available knee clearance at 9 inches (230 mm) above the floor shall not be considered toe clearance.

306.2.5 Width. Toe clearance shall be 30 inches (760 mm) minimum in width.

306.3 Knee Clearance.

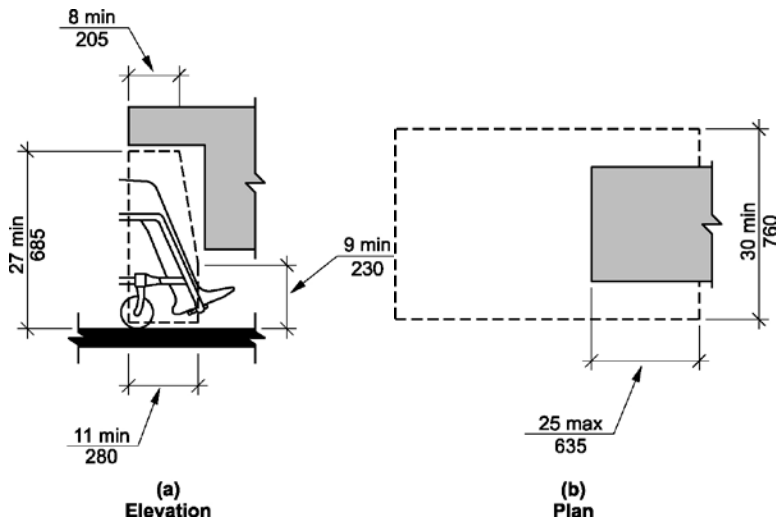

Figure 306.3 – Knee clearance
 a) elevation
 b) plan

306.3.1 General. Space beneath an element between 9 inches (230 mm) and 27 inches (685 mm) above the floor shall be considered knee clearance and shall comply with Section 306.3.

306.3.2 Maximum Depth. Knee clearance shall be permitted to extend 25 inches (635 mm) maximum under an element at 9 inches (230 mm) above the floor.

306.3.3 Minimum Depth. Where knee clearance is required beneath an element as part of a clear floor space complying with Section 305, the knee clearance shall be 11 inches (280 mm) minimum in depth at 9 inches (230 mm) above the floor, and 8 inches (205 mm) minimum in depth at 27 inches (685 mm) above the floor.

306.3.4 Clearance Reduction. Between 9 inches (230 mm) and 27 inches (685 mm) above the floor, the knee clearance shall be permitted to be reduced at a rate of 1 inch (25 mm) in depth for each 6 inches (150 mm) in height.

306.3.5 Width. Knee clearance shall be 30 inches (760 mm) minimum in width.

307 Protruding Objects

307.1 General. Protruding objects on circulation paths shall comply with Section 307.

307.2 Protrusion Limits. Objects with leading edges more than 27 inches (685 mm) and not more than 80 inches (2030 mm) above the floor shall protrude 4 inches (100 mm) maximum horizontally into the circulation path.

EXCEPTION: Handrails shall be permitted to protrude 4 1/2 inches (115 mm) maximum.

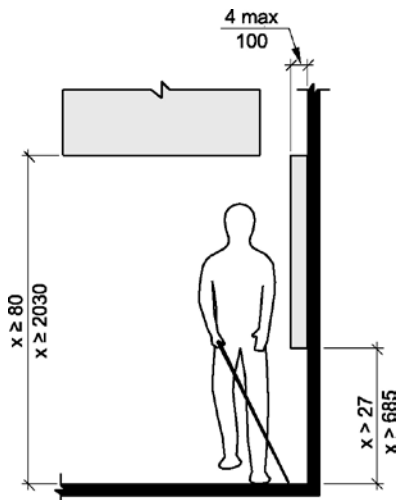
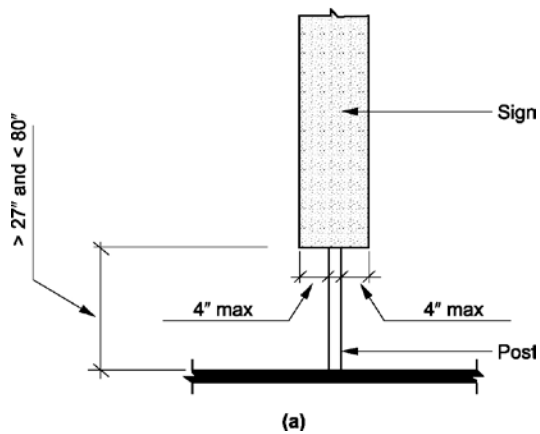

Figure 307.2 Limits of protruding objects

307.3 Post-Mounted Objects. Objects on posts or pylons shall be permitted to overhang 4 inches (100 mm) maximum where more than 27 inches (685 mm) and not more than 80 inches (2030 mm) above the floor. Objects on multiple posts or pylons where the clear distance between the posts or pylons is greater than 12 inches (305 mm) shall have the lowest edge of such object either 27 inches (685 mm) maximum or 80 inches (2030 mm) minimum above the floor.

EXCEPTION: Sloping portions of handrails between the top and bottom riser of stairs and above the ramp run shall not be required to comply with Section 307.3.



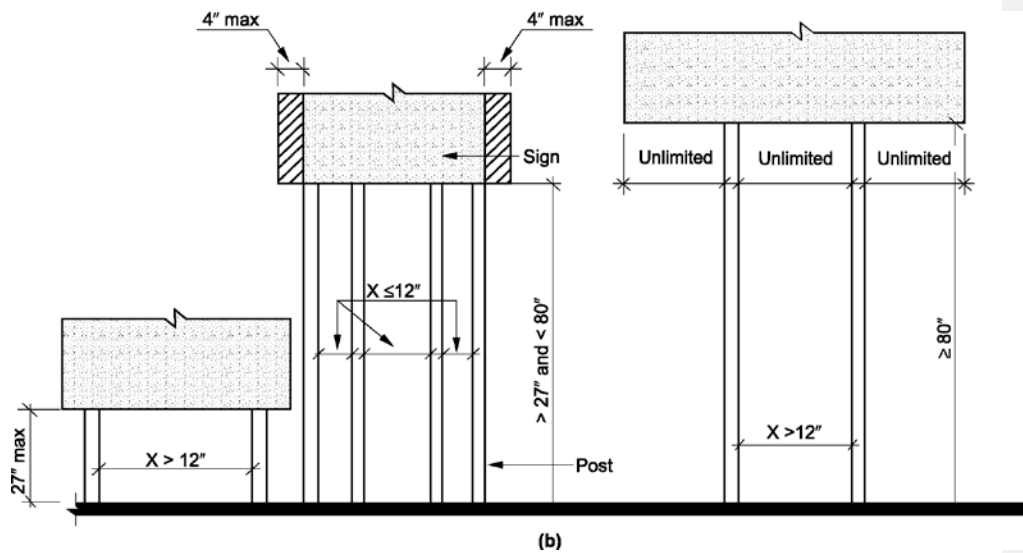

Figure 307.3 (a)&(b) Post-mounted protruding objects

307.4 Vertical Clearance. Vertical clearance shall be 80 inches (2030 mm) minimum in height. Rails or other barriers shall be provided where the vertical clearance is less than 80 inches (2030 mm) in height. The leading edge of such rails or barrier shall be located 27 inches (685 mm) maximum above the floor.

EXCEPTION: Door closers and door stops shall be permitted to be 78 inches (1980 mm) minimum above the floor.

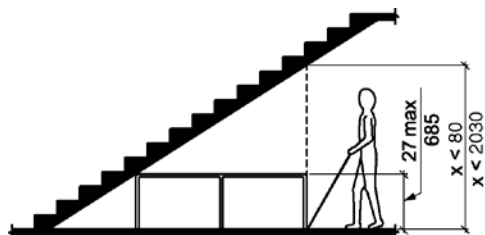

Figure 307.4 Reduced vertical clearance

307.5 Required Clear Width. Protruding objects shall not reduce the clear width required for **accessible** routes.

308 Reach Ranges

308.1 General. Reach ranges shall comply with Section 308.

308.2 Forward Reach.

308.2.1 Unobstructed. Where a forward reach is unobstructed, the high forward reach shall be 48 inches (1220 mm) maximum and the low forward reach shall be 15 inches (380 mm) minimum above the floor. (3-20-12 PC1, PC3 through PC6) (3-6-12 PC2.1)

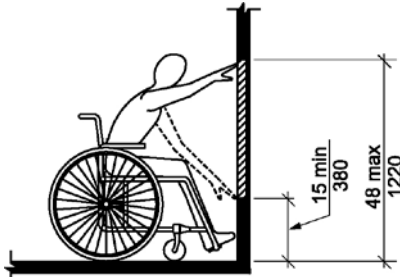

Figure 308.2.1 Unobstructed forward reach

308.2.2 Obstructed High Reach. Where a high forward reach is over an obstruction, the clear floor space complying with Section 305 and knee and toe clearance complying with Section 306 shall extend beneath the element for a distance not less than the reach depth over the obstruction. The high forward reach shall be 48 inches (1220 mm) maximum above the floor where the reach depth over the obstruction is 20 inches (510 mm) maximum. The high forward reach shall be 44 inches (1120 mm) maximum above the floor where the reach depth over the obstruction is greater than 20 inches (510 mm) and not more than 25 inches (635 mm). (3-20-12)(3-21-12 PC2)

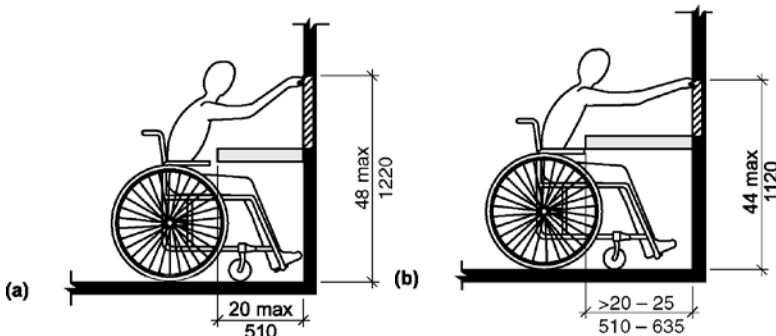

Figure 308.2.2 (a)&(b) Obstructed high forward reach

308.3 Side Reach.

308.3.1 Unobstructed. Where a clear floor space complying with Section 305 allows a parallel approach to an element and the edge of the clear floor space is 10 inches (255 mm) maximum from the element, the high side reach shall be 48 inches (1220 mm) maximum and the low side reach shall be 15 inches (380 mm) minimum above the floor.

EXCEPTIONS:

1. Existing elements that are not altered shall be permitted at 54 inches (1370 mm) maximum above the floor.
2. Operable parts on fuel dispensers installed on an existing curbs shall be permitted at 54 inches (1370 mm) maximum above the floor. (3-23-12)
3. ~~Mailboxes serving Type B dwelling units and complying with Section 1401.2 shall be permitted an unobstructed high side reach 54 inches (1370 mm) maximum above the floor. (3-24-12 PC1)~~

Note: Mailbox proposal from Cheryl Kent was withdrawn, therefore, this exception is no longer

Comment [KP2]: Found by ICC staff – after ETG finished work.

appropriate. (New)

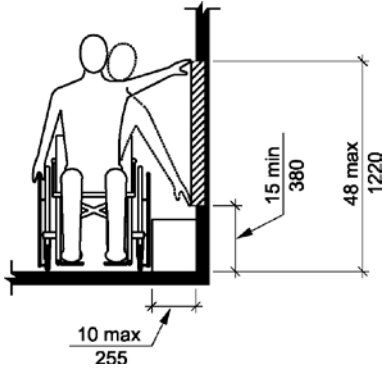

Figure 308.3.1 - Unobstructed side reach

308.3.2 Obstructed High Reach. Where a clear floor space complying with Section 305 allows a parallel approach to an element and the high side reach is over an obstruction, the height of the obstruction shall be 34 inches (865 mm) maximum above the floor and the depth of the obstruction shall be 24 inches (610 mm) maximum. The high side reach shall be 48 inches (1220 mm) maximum above the floor for a reach depth of 10 inches (255 mm) maximum. Where the reach depth exceeds 10 inches (255 mm), the high side reach shall be 46 inches (1170 mm) maximum above the floor for a reach depth of 24 inches (610 mm) maximum.

EXCEPTION: At washing machines and clothes dryers, the height of the obstruction shall be permitted to be 36 inches (915 mm) maximum above the floor. (6-69-12)

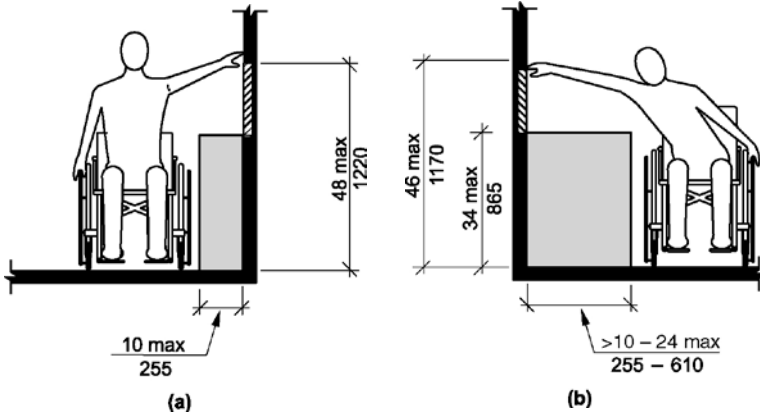

Figure 308.3.2 (a)&(b) - Obstructed high side reach

309 Operable Parts

****309.1 General.** Operable parts ~~required to be accessible~~ shall comply with Section 309.

EXCEPTIONS:

1. Receptacle outlets serving a dedicated use.

2. Where two or more receptacle outlets are provided in a kitchen above a length of counter top that is uninterrupted by a sink or appliance, one receptacle outlet shall not be required to comply with Section 309.

3. In a kitchen, where a clear floor space for a parallel approach cannot be located at a counter top in a corner between appliances, receptacle outlets over the counter top shall not be required to comply with Section 309 provided that the counter top area does not exceed 9 square feet (0.835 m²) maximum. (10-8-12 PC2)

3. Floor receptacle outlets.

4. HVAC diffusers.

5. Controls mounted on ceiling fans.

6. Where redundant controls other than light switches are provided for a single element, one control in each space shall not be required to **be accessible** comply with Section 309.

7. Reset buttons and shut-offs serving appliances, piping and plumbing fixtures.

8. Electrical panelboards shall not be required to comply with Section 309.4. (3-27-12)

9. Emergency aid devices, such as fire department hose connections, valve controls, gauges, police call boxes and annunciator panels shall not be required to comply with Section 309 provided that they are used only for emergencies by emergency personnel acting in their official capacity. (5-24-12 PC1.1)

(Note: There was an approved proposal (3-27-12) to duplicate the exceptions from 1002.9, 1003.9 and 1004.9. This new exception was added to address kitchens in 1002.9, 1003.9 and 1004.9 – same issue exists for common use kitchens which would use this section, so it should be repeated here.)

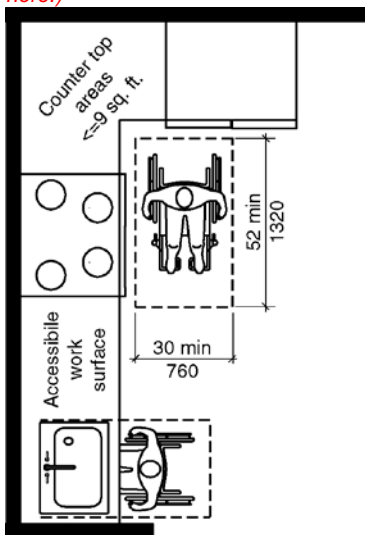

Figure 309.1 - Operable parts – Exception 3

Comment [KP3]: Moved from 1102.9

309.2 Clear Floor Space. A clear floor space complying with Section 305 shall be provided.

309.3 Height. Operable parts shall be placed within one or more of the reach ranges specified in Section 308.

309.4 Operation. Operable parts shall be operable with one hand and shall not require tight grasping, pinching, or twisting of the wrist. The force required to activate operable parts shall be 5.0 pounds (22.2 N) maximum.

EXCEPTION: Gas pump nozzles shall not be required to provide operable parts that have an activating force of 5.0 pounds (22.2 N) maximum.